

OWNER'S MANUAL

*Model 466
464 Update Kit*

HARVEST
**TEC** *Equipment and Products
for Quality Hay.™*

P.O. Box 63 • 2821 Harvey Street • Hudson, WI 54016
800-635-7468 • www.harvesttec.com

010-0466

REVISED 12-07

HARVEST TEC 466 TABLE OF CONTENTS

	<u>PAGE</u>
TOOLS NEEDED	3
INSTALLATION OF APPLICATOR	4-11
1. REMOVING 464 COMPONENTS	4
2. INSTALLING THE 465 COMPONENTS	4-5
3. INSTALLATION OF PLUMBING	5
4. WIRING INSTALLATION	6
5. DESCRIPTION OF BUTTONS	7
6. FIRST TIME AND ANNUAL START UP INSTRUCTIONS	8
CHECKING AND PRIMING PUMPS	8
7. SETTING UP SYSTEM FOR INITIAL USE	9-10
APPLICATION RATE	9
BALING RATE	10
OPERATING INSTRUCTIONS	11-14
AUTOMATIC MODE	11
MANUAL MODE	12
JOB RECORDS	13
DIAGNOSTICS	14
COMMON QUESTIONS ABOUT THE 465	15
MAINTENANCE	16
WINTER STORAGE	16
TROUBLE SHOOTING CHECKS	17-18
BACKUP FUSE	18
WIRING DIAGRAMS	19-20
PARTS BREAKDOWN	21
PUMP PLATE TEMPLATE	22
NOTES	23
WARRANTY STATEMENT	Back Page

INTRODUCTION

The Harvest Tec auto upgrade kit is designed to give you all of the advanced features of the new Harvest Tec 465 Touch Screen Monitor and Baler Mounted processor. The 465 applicator will apply preservative from 44 lbs/hr up to 632 lbs/hr. This applicator is designed to apply Harvest Tec buffered propionic acid. The use of other products can cause application problems and damage to system components. The advanced touch screen technology allows for simple operation. Also, the built in modes and settings allow for a user-friendly application process. The following pages will guide you through the setup of the kit and will explain how to operate the 465.

TOOLS NEEDED

- Standard wrench set
- Standard socket set
- Standard screw driver or 5/16" nut driver
- Side cutter
- Hose cutter
- Crescent wrench
- Hammer
- Metal drilling and cutting tools
- Center Punch

INSTALLATION OF APPLICATOR

1. REMOVING 464 COMPONENTS

CONTROL BOX AND MAIN WIRING HARNESS

1. The 464 control box will need to be removed from the cab of the tractor including the mounting bracket.
2. The existing power cable will need to be removed and replaced with the one supplied in the kit. Route the new cable from the battery to the drawbar on the tractor.
3. The main wiring harness will need to be removed from the cab. Remove the cable on the baler up to the signal conditioner. If crop eyes are attached disconnect from main harness.

PUMP PLATE AND SIGNAL CONDITIONER

1. Remove the wires that are attached to the signal conditioner.
2. Remove the hoses attached to the pumps taking care to mark the hoses to their pumps accordingly. Number the hoses according to the pumps 1,2 and 3 with pump 1 being closest to the filter bowl and pump 3 being farthest away from the filter bowl.
3. Remove the pump plate assembly by removing the 3/8" bolts, locks and nuts.
4. Remove the signal conditioner from the pump plate by removing the screws on all four corners.
5. Do not reinstall the pump plate at this time.

2. INSTALLING THE 465 COMPONENTS

INSTALLATION OF CONTROLS

Use the four mounting screws to mount the round base in a convenient area in your cab or on your fender. If unit is mounted on fender it will need to be removed at night and stored in a clean, dry area.

Use the Ram mount swivel-positioning nut to tighten the entire assembly. Adjust it so that you can view the entire screen and be able to use the touch screen without interfering with other tractor functions.

INSTALLATION OF DISPLAY CABLE HARNESS

On the bottom of the touch screen display you will find the main display wire plug. The harness (006-4660N) will need to be attached to this plug and run through the cab towards the hitch where it will connect with its matching harness (006-4660L) from the baler mounted processor.

INSTALLATION OF PUMP JUMPER WIRE

1. Remove existing amp plug and wires, which connect to pumps.
2. Locate wire harness number 006-4660Z
3. The six pigtail wire will need to be connected to the pumps in the following order: pump1 (closest to the filter bowl) orange, pump 2 (middle pump) green wires, pump 3 (farthest away from the filter bowl) yellow wires.
4. The amp connection on this harness will attach to the baler mounted processor.

INSTALLATION OF BALER MOUNTED PROCESSOR

The pump plate removed earlier will need to be modified to fit the baler mounted processor. Use the supplied diagram found at the end of the manual to drill the holes for the baler mounted processor and filter bowl. Do not install baler mounted processor at this time. It will be installed when all wires have been attached.

MAIN WIRING HARNESS AND POWER CORD INSTALLATION



Route cords 006-4660L and 006-4660K along this path or similar inside of the baler. Keep cords away from moving parts and hydraulic hoses. Secure with existing cable locks or use cable ties.

Route the cords 006-4660L and 006-4660K using path shown above.

3. PLUMBING

1. Locate the three ¼" hoses. The pumps will need to be connected to specific tips so the pump numbers are as follows: Pump 1 is closest to the filter bowl pump 2 is in the middle and pump 3 is the outside pump.
2. Use warm soapy water when connecting the hose to the pumps located inside the pump plate and install hose clamps at the same time. Because all nozzles on the spray shield are different, the operator will need to install pump 1 to the orange tips, pump 2 to the green tips, and pump 3 to the blue tips. New tips are supplied with the kit
3. **KEEP HOSE AWAY FROM: MOVING PARTS, SHARP METAL, AND HYDRAULIC LINES. WORKING TEMPERATURE FOR THE HOSE IS 140 °F AND UNDER.**
4. Tie the hose down at secure locations on the baler using the enclosed tie straps and cable clamps.

A. High and Low Output Tips

Your baler comes with two sets of tips: a low set and a high set. The high set comes factory installed.

-The high set will cover outputs of 84 to 632 lbs/hr (Apprx. 21-63 tons/hr) Install the following tips for high output:

Pump 1 to orange tips

Pump 2 to green tips.

Pump 3 to blue tips.

-The low set will cover outputs of 44 to 400 lbs/hr (Apprx. 11-40 tons/hr) Install the following tips for low output:

Pump 1 to brown tips.

Pump 2 to orange tips.

Pump 3 to green tips.

****Refer to Tip Output under APPLICATION RATE of the control unit to calibrate system.**

****If your system does not have three color hoses you must label your clear hoses**

****for correct pump and tip coordination.**

4. WIRING INSTALLATION

1. Locate the power harness.
2. Connect the power harness (006-4640A) to the battery (12 volt) using the red wire with fuse to the positive side and the black wire to the negative.
 - a. **The power harness must be connected to the battery!** The unit will draw more amps than convenience outlets can handle. Any modifications of the power harness will void systems warranty. **IF MODIFICATIONS ARE REQUIRED CONTACT HARVEST TEC FIRST!**
 - b. **This unit will not function on positive ground tractors.**
 - c. **If the unit loses power while operating it will not keep track of accumulated pounds of product used.**
3. The power harness (006-4640A) will run from the tractor battery to the hitch. The power harness (006-4660K) will connect to the tractor power harness (006-4640A) at the hitch. Run the Communication harness (006-4660N) from the cab to the hitch. This wire will connect to the Communication harness (006-4660L). These wires will run together to the Baler Mounted Processor (006-4671LS).
4. Connect Flow Meter (006-4725A) to the Baler Mounted Processor.
5. Connect Pump Harness (006-4660Z) the Baler Mounted Processor.
6. If you have the optional Hay Indicator kit connect it to the Baler Mounted Processor.
7. Attach moisture cable (006-4640E) to Baler Mounted Processor.
8. Install Baler Mounted Processor in pump plate using 5/16" lock, nut and flat washers.



NOTE: The plugs on the Baler Mounted Processor must face down. Failure to mount correctly will void systems warranty.

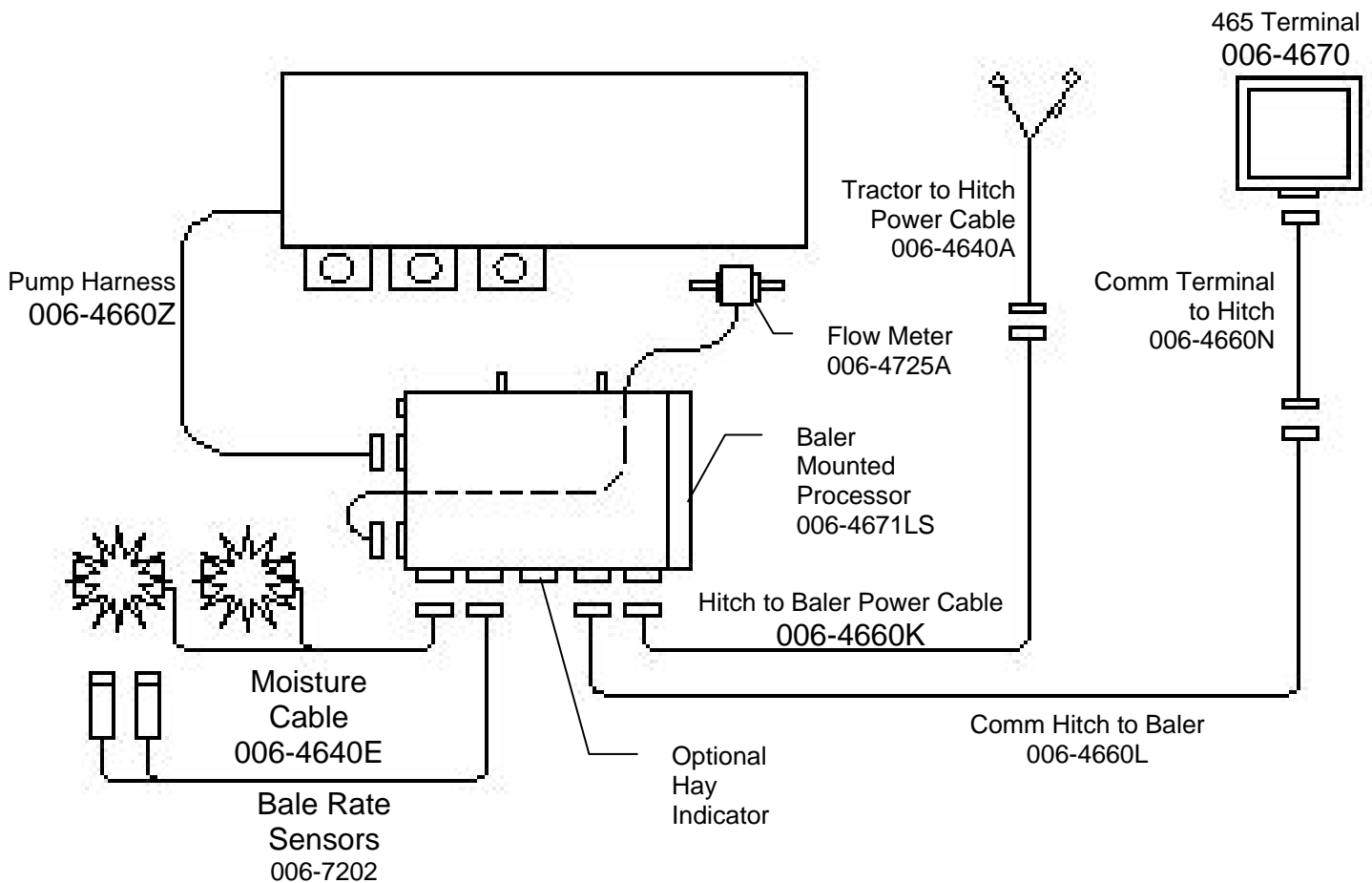

5. DESCRIPTION OF BUTTONS

This system is calibrated for use with Harvest Tec buffered propionic acid. The use of other products can cause application problems and damage to system components. It is designed to apply rates of 44 to 632 pounds of acid per hour and read moisture levels of 10 to 70 percent. The 465 monitor will allow you to set your bale size, weight, single bale formation time, moisture levels and application rates. The automatic mode will automatically adjust the application rates as the moisture level changes. Manual mode will allow you to control the application rates on the go.

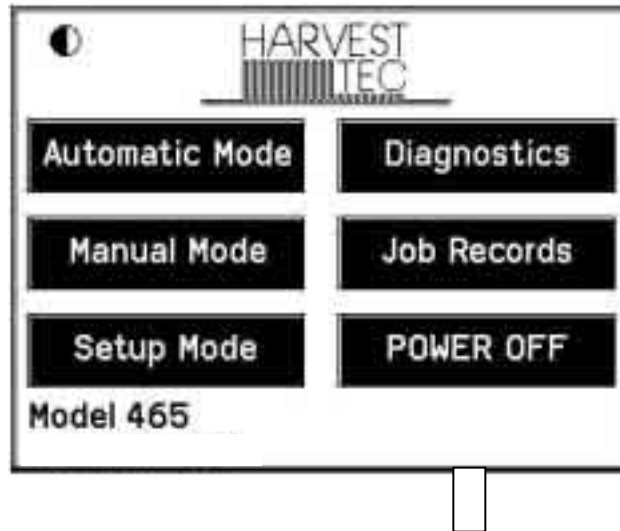

AUTOMATIC MODE This mode allows you to use all of the applicators features such as adjusting preservative application on the go and counting total pounds of product used.

MANUAL MODE Allows operator to manually turn pumps on and off. This mode also has moisture content displayed. Use this mode to prime pumps.

SETUP MODE This mode allows the operator to adjust bale rate and application rate settings and view or change tip selection.

DIAGNOSTICS Allows operator to automatically check performance and output of pumps as well as set the date and time.

JOB RECORDS Keeps track of up to 63 jobs with total product used, average moisture content, tons baled, and date of baling.

POWER OFF This key turns the unit off. Press anywhere on the right side of the screen to turn the unit on followed by pressing the "Press to Start" key within 5 seconds.

 **CONTRAST** This button is your contrast control. Press this button to lighten the screen. When the screen reaches its lightest point, pressing again will return to the darkest setting. Fine tuning the contrast can be accomplished by turning the knob on the bottom right side of the enclosure.

6. FIRST TIME AND ANNUAL START UP INSTRUCTIONS

AFTER INSTALLATION THE UNIT MUST BE CHECKED OUT BEFORE FIELD OPERATION!!

CHECKING AND PRIMING THE PUMPS

1. Put 10 gal of water in tank and turn main ball valve on.
2. Inspect for any leaks or drips at this time. If any are found tighten or replace area or fitting.
3. **Turn controller on** (push anywhere on the screen followed by pressing on the press to start key).
4. Press the SETUP MODE key. (**See page 10**) **Select Sensors are: OFF** to disable bale rate sensors. Make sure the AVG Bale Weight is 1500 lbs and the AVG Baler Length is 96 in. and EST Baling Time is 60 sec. Press the MAIN MENU key to return to the opening screen.
5. Press the MANUAL MODE key.
6. The screen shown below should appear.
7. The rates listed below are for Harvest Tec buffered propionic acid. Other products will need to be collected and weighed to assure proper performance is achieved.

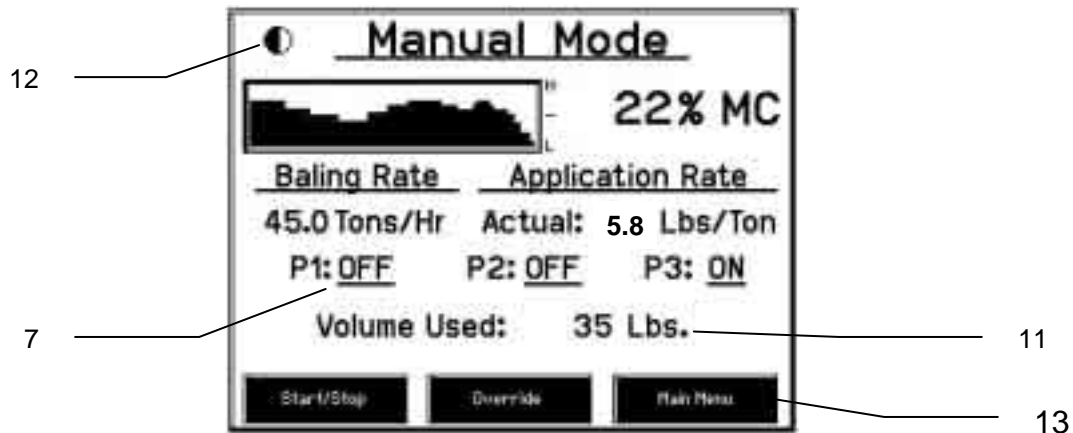

8. NOTE: THE SYSTEM COMES WITH THE HIGH TIPS ALREADY INSTALLED ON THE SPRAY SHIELD. TEST SYSTEM WITH TIPS YOU WILL USE MOST OFTEN.

- **With low tips in:** Turn pump 1 on (P1). To do this press the underlined area on the screen which says OFF. The application rate should then read between .7 – 1.2 Lbs/Ton. Ideally, at 13.5 volts, the rate would read 1.0 Lbs/Ton.
 - Repeat the process for pumps 2 and 3 (P2 and P3). The application rate should read between 1.7 – 2.4 Lbs/Ton and 2.5 – 3.5 Lbs/Ton respectively. Ideally, at 13.5 volts, the rate for pump 2 would be 2.0 Lbs/Ton; pump 3 would be 3.0 Lbs/Ton.
 - **With high tips in:** Turn pump 1 on (P1). To do this press the underlined area on the screen which says OFF. The application rate should then read between 1.3 – 1.9 Lbs/Ton. Ideally, at 13.5 volts, the rate would read 1.6 Lbs/Ton.
8. Repeat the process for pumps 2 and 3 (P2 and P3). The application rate should read between 2.6 – 3.6 Lbs/Ton and 4.9 – 6.8 Lbs/Ton respectively. Ideally, at 13.5 volts, the rate for pump 2 would be 3.1 Lbs/Ton; pump 3 would be 5.8 Lbs/Ton.
 9. This process will also be used to prime the pumps whenever needed.
 10. While running pumps check for a good spray pattern out of the respective tips and verify that no parts of the system are leaking.
 11. While doing these tests the Volume Used on the bottom of the screen should be counting up, this verifies that the flow meter is functioning.
 12. This button is your contrast control. Press this button to lighten the screen. When the screen reaches its lightest point, pressing again will return to the darkest setting.
 13. Press the MAIN MENU key to return to the initial start up screen.

NOTE: It is recommended that the system be run with the bale rate sensors on. Press the SETUP MODE key and turn the bale rate sensors back on for normal operation. (Also see Baling Rate to adjust bale weight, length, and time.)

7. SETTING UP SYSTEM FOR INITIAL USE

In this mode you will setup your initial application rate and baling rate.

APPLICATION RATE

After pushing the SETUP MODE key in the Main Menu screen, the top left screen will show on the display:

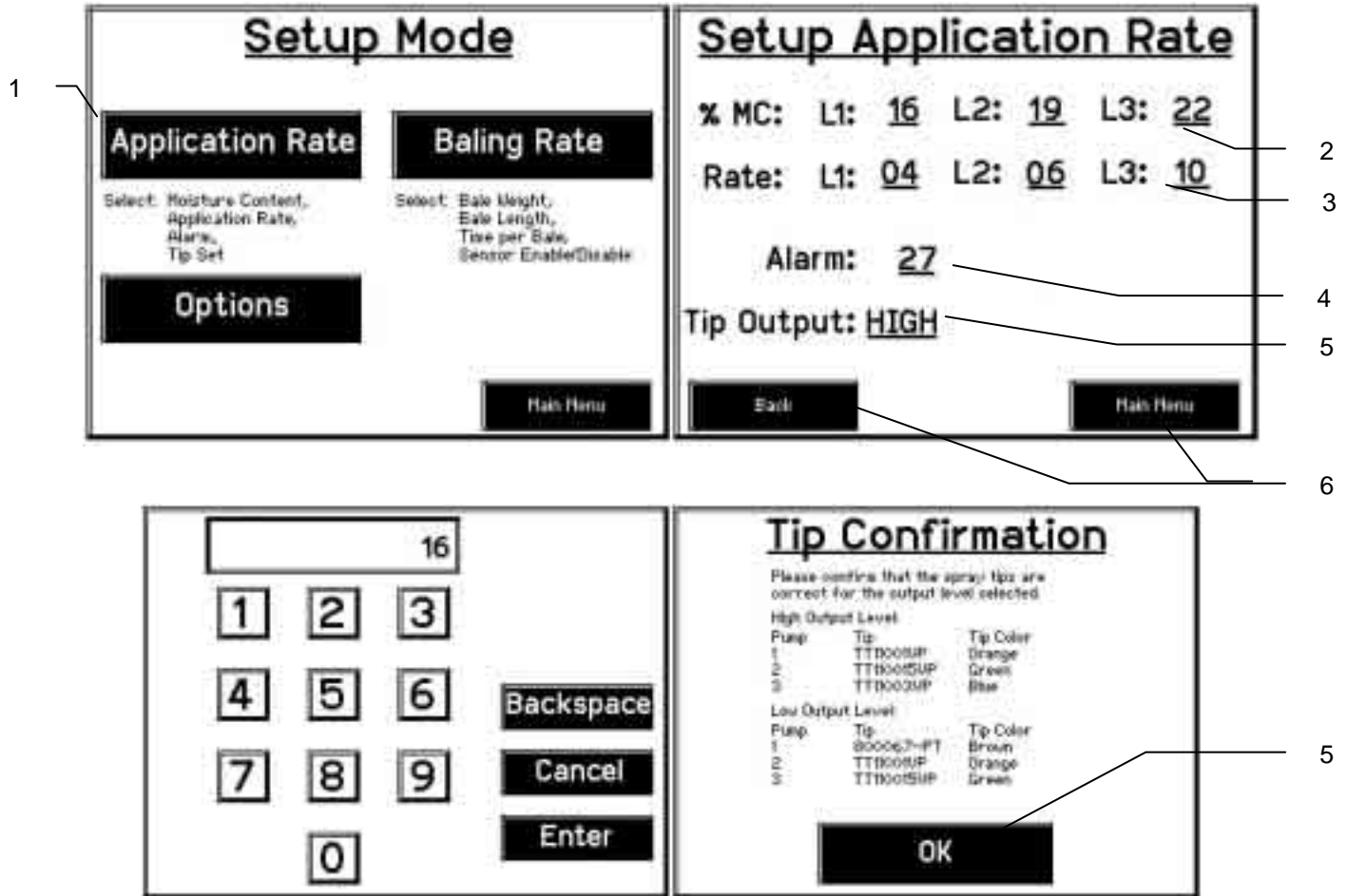

1. On this screen the operator will press the APPLICATION RATE key. Once pressed the SETUP APPLICATION RATE screen will be shown. (Top right picture)
2. Press any of the underlined numbers to the right of %MC to adjust their figures. The key pad shown on the bottom left will display. Remember level 1 must be lower than level 2 and level 2 must be lower than level 3. Harvest Tec products recommend set points of 16, 19 and 22% MC levels. These are preset from the factory. Press ENTER to return to previous screen.
3. To change rate of chemical application press any of the underlined numbers to the right of RATE:. The key pad shown on the bottom left will display. Remember level 1 must be lower than level 2 and level 2 must be lower than level 3. Harvest Tec products recommend rates of 4, 6, and 10 lbs/ton. These rates are preset from the factory. Press ENTER to return to previous screen. **IT IS THE OPERATORS RESPONSIBILITY TO FOLLOW THE RECOMMENDATIONS OF THE PRESERVATIVE. ONLY THE OPERATOR CAN APPLY THE PROPER RATE.**
4. To set the alarm press on the underlined area and set the level at which you want the alarm to activate. To turn the alarm off, set level above 35.
5. To change the tip output setting to either low or high, press the underlined word to the right of Tip Output:. In the TIP CONFIRMATION screen the operator can verify and change tip selection. After tips have been verified or changed press the OK key to return to the previous screen.
6. Next press the BACK key found on the bottom left hand figure of the screen to return to Setup Mode screen or press the MAIN MENU key on the bottom right hand figure of the screen to return to the opening screen.

BALING RATE

After pushing the SETUP MODE key in the Main Menu screen, the top screen should appear:

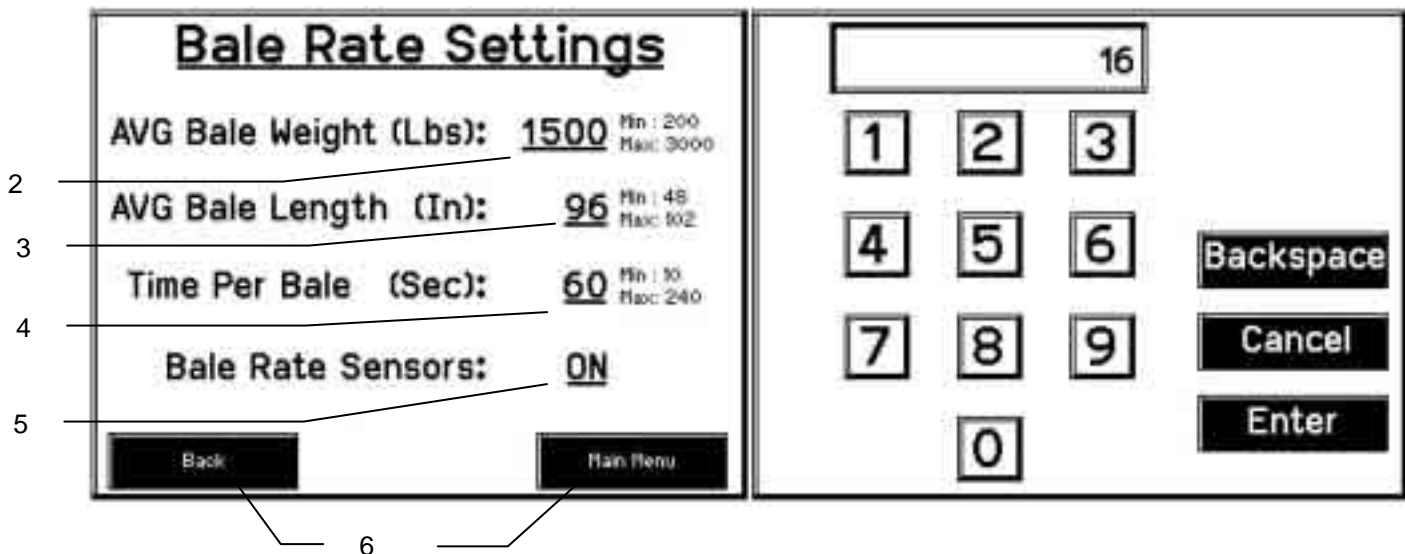
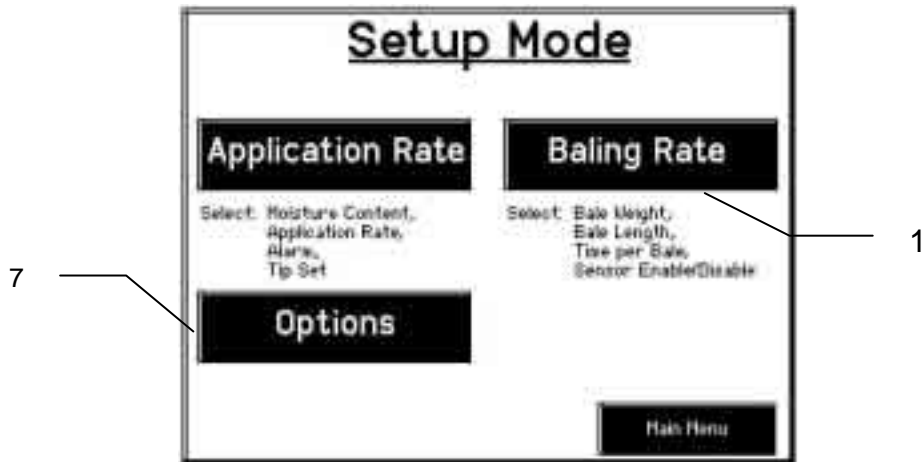

1. On this screen the operator will press the BALING RATE key. This screen is shown on the bottom left picture shown above.
2. Press the underlined number to the right of AVG Bale Weight (Lbs): to adjust the weight of your bales. The key pad shown on the right side will display. Press any number combination in this screen within the min/max limits. Press the ENTER key to save this information. The information will remain until it is changed again.
3. Press the underlined number to the right of AVG Bale Length (In): to adjust the length of your bales. The key pad shown on the right side will display. Press any number combination in this screen within the min/max limits. Press the ENTER key to save this information. The information will remain until it is changed again.
4. Press the underlined number to the right of EST Baling Time (Sec): to adjust the time it takes to make a bale. The key pad shown on the right side will display. Press any number combination in this screen within the min/max limits. Press the ENTER key to save this information. The information will remain until it is changed again.
5. If the unit will be run with the bale **sensors on**, then the bale weight and length will need to be inputted. When the **sensors are:** on, the applicator will calculate your tons per hour. When the **Sensors are:** off (as shown above), a constant tons per hour (your inputted bale weight and time) will be used. Press the underlined word to toggle between on or off.
6. Next press the BACK key found on the bottom left hand of the screen to return to the Setup Mode screen, or press the MAIN MENU key on the bottom right hand of the screen to return to the opening screen.
7. Press the OPTION key to adjust the touchscreen between metric and standard units and languages.

OPERATING INSTRUCTIONS

Auto mode will automatically apply product based on both hay moisture content sensed by the star wheels and the operator's presets. (See SETTING UP SYSTEM FOR INITIAL USE to change any of these settings). **Manual mode will apply preservative to the hay at a fixed rate regardless of the moisture content.**

AUTOMATIC MODE

After pushing the AUTOMATIC MODE key in the Main Menu screen, the following screen should appear:

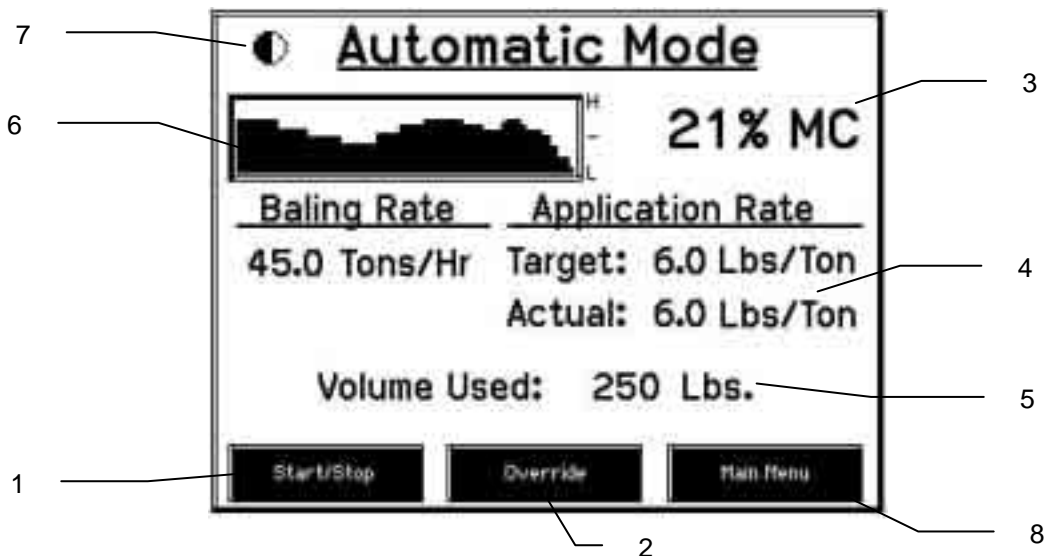

1. Push the START/STOP key to pause the unit while in operation.
2. Push the OVERRIDE key to turn on all three pumps at the same time for full output of the system. Use this mode when going through a short area of wet crop.
3. The moisture content is shown in the upper right hand corner.
4. Baling Rate and Application Rate are shown in the middle. The operator sets the target application rate in the setup mode; the actual rate should be within +/- one pound when running. The baling rate is also set in Setup Mode.
5. Volume used shown at the bottom of the screen will show accumulated pounds of preservative used on the go. This number will reset at power down, but remains in the job record screen. **NOTE: Initial start-up requires pressing the New Job key in the Job Records screen in order for Volume Used accumulation to be recorded. This only needs to be done once on initial start-up of system and not every time the system is started for operation.** (See JOB RECORDS screen)
6. The graph shows the moisture trend from the past 90 seconds in 3 second intervals.
7. This button is your contrast control. Press this button to lighten the screen. When the screen reaches its lightest point, pressing again will return to the darkest setting.
8. Press the MAIN MENU key to return to the opening screen.

MANUAL MODE

After pushing the MANUAL MODE key in the Main Menu screen, the following screen should appear:

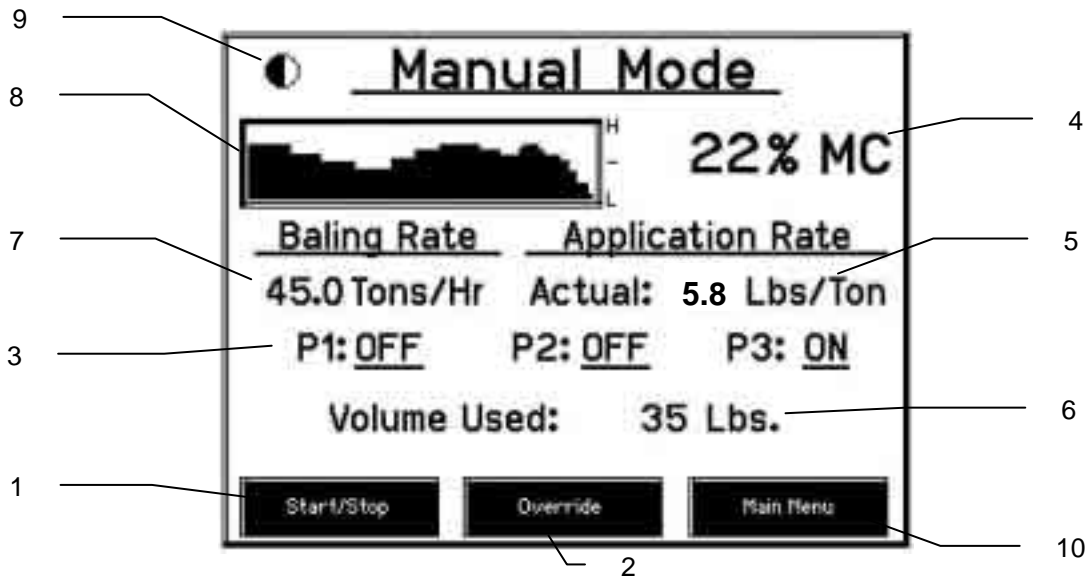

1. Push the START/STOP key to pause the system while in operation.
2. Push the OVERRIDE key to turn on all three pumps at the same time for full output of the system. Use this mode when going through a short area of wet crop.
3. In Manual Mode you can turn the pumps on or off by pressing the underlined area next to the pump numbers. In Manual Mode (regardless of moisture, tons per hour or bale weight) the outputs of the pumps are fixed rates as follows:

Low output tips:

Pump 1 = 45 LBS/HR
 Pump 2 = 90 LBS/HR
 Pump 3 = 135 LBS/HR

High output tips:

Pump 1 = 75 LBS/HR
 Pump 2 = 140 LBS/HR
 Pump 3 = 265 LBS/HR

4. The moisture content is shown in the upper right hand corner.
5. Baling rate and Application rate are shown in the middle. The output of a pump can be checked by dividing the preset output (shown in step 3) by the baling rate. For example, if you have the high output tips in and are running pump three by itself, your output is 265 lbs/hr. Given the baling rate shown on the above screen (45.0 tons/hr), the application rate should be about 5.8 lbs/ton (265lbs/hr divided by 45.0 tons/hr).
6. Volume used shown at the bottom of the screen will show accumulated pounds of preservative used on the go. This number will reset at power down, but remains in the job record screen. **NOTE: Initial start-up requires pressing the New Job key in the Job Records screen in order for Volume Used accumulation to be recorded. This only needs to be done once on initial start-up of system and not every time the system is started for operation.** (See JOB RECORDS screen)
7. The baling rate is set in the Setup Mode menu.
8. This graph shows the moisture trend from the last 90 seconds of baling (one reading every 3 seconds).
9. This button is your contrast control. Press this button to lighten the screen. When the screen reaches its lightest point, pressing again will return to the darkest setting.
10. Press the MAIN MENU key to return to the opening screen.

JOB RECORDS

After pushing the JOB RECORDS key in the Main Menu screen, the following screen should appear:



1. The job number will be displayed in the top left corner and will move to the next job when the NEW JOB key is pressed. The current job being viewed will always read "Job #: 0". Product used and average moisture content will be reset when the NEW JOB key is pressed. The job records screen will store up to 63 jobs and will allow you to access previous jobs by using the up and down arrows found on the right side of the screen.
2. Scrolling through previous jobs is done by pressing the UP or Down keys.
3. **Every time the NEW JOB key is pressed the accumulated pounds on auto and manual modes will be reset to zero.** After 63 jobs have been stored, the next time the NEW JOB key is pressed the system will start over with job one and the old job will be replaced.
4. To return the opening screen, press the MAIN MENU key.

NOTE: Initial start-up requires pressing the New Job key in the Job Records screen in order for Volume Used accumulation to be recorded. This only needs to be done once on initial start-up of system and not every time the system is started for operation.

NOTE: Total Baled will not accumulate with the bale rate sensors off.

DIAGNOSTICS

After pushing the DIAGNOSTICS key in the Main Menu screen, the following screen should appear:

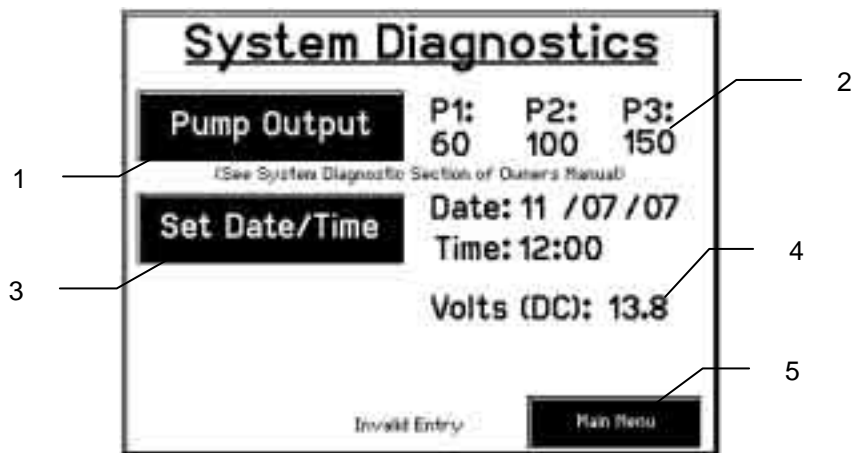

The diagnostic mode will automatically check the pump output and performance of the three pumps. It is recommended to use this mode daily to ensure proper system performance.

Acceptable ranges for output:

Low output tips:

Pump 1 = 38 - 53 LBS/HR
Pump 2 = 76 - 105 LBS/HR
Pump 3 = 115 - 160 LBS/HR

High output tips:

Pump 1 = 64 - 88 LBS/HR
Pump 2 = 119 - 165 LBS/HR
Pump 3 = 225 - 312 LBS/HR

1. Once the screen is displayed, press the PUMP OUTPUTS key.
The machine will cycle all three of the pumps for 15 seconds. After the cycles are complete, the system will display a number next to each pump number.
2. **If the system displays within the listed range.**
 - A. The system is operating correctly.**If the system displays higher than the listed range, some common problems could be:**
 - A. Leak in line. Inspect lines thoroughly.
 - B. Tip missing. Check for lost or broken tip on spray shield.
 - C. Tip worn. Replace tip.
 - D. High tractor voltage.**If the system displays lower than the listed range, some common problems could be:**
 - A. Make sure there is preservative in the tank and ball valve is in the open position.
 - B. Air in lines. Pump will not prime. Check for leak in lines, or defective check valve.
 - C. Pump is working, but not producing desired output. Pump needs to be rebuilt.
 - D. Main filter plugged. Check filter by tank and clean if necessary.
 - E. Tip or tip screen plugged. Check both tip and tip screen and clean if necessary.
 - F. Kink in hose. Straighten or replace hose.
 - G. Voltage from tractor is low. Check power cord with multimeter for 12 volts at baler mounted processor. Clean connections on battery. Dielectric grease connections at baler mounted processor and at hitch connection.
 - H. Pump is defective. Rebuild pump if motor runs smoothly. Replace pump if motor is bad.
 - I. Defective flow meter. Only if all pumps run, product is applied, and all numbers read 0.
3. To set date and time, press the SET DATE/TIME key. In the next screen enter the date (month, day, year format) followed by the time. When done press the ENTER key. NOTE: The clock uses military (or 24 hour) time.
4. The voltage should be between 12.0 to 14.5 volts for the system to work properly. If voltage is not in this range check all power cord connections and the tractors charging system.
5. When done in this mode, press the MAIN MENU key.

COMMON QUESTIONS ABOUT THE 465

1. How do I turn the system on/off?

To turn the system ON simply press anywhere on the right side of the screen followed by pressing the “Press to Start” key. To turn the system OFF, return to the Main Menu screen and press the POWER OFF key.

2. How to get in the LBS/TON, MC%, and TONS/HR menus?

In the Main Menu press the SETUP MODE key. From this screen you can change your application rates and how much product is applied. See SETTING UP FOR INITIAL USE for a detailed explanation of this process.

3. The unit is stuck in the MC% screen.

In the MC% screen, level 1 must be less than level 2, and level 2 must be less than level 3. For example, if level 1 is set at 16, level 2 must be set at 17 or higher, and level 3 must be set higher than level 2.

4. How does OVERRIDE work?

Override turns on all three pumps at full output. The pumps will remain at full output until the operator turns these pumps off by pressing the OVERRIDE key again.

5. The flow meter reading is more or less than the programmed level set in the box.

Some variation in flow meter readings compared to the programmed set point is normal due to factory tolerances on the pump motors as well as varying tractor voltages inputted to the control box. The flow meter reading is an accurate measure of how much product is actually being applied. The set points then will need to be adjusted if you want to attain a different flow meter reading.

6. Why don't all the pumps turn on even at higher application rates?

The selections of what pumps turn on when are automatically controlled by the control box's flow rate look up chart. Thus, not all the pumps turn on at once and the combination of what pumps turn on when is automatically controlled by the software. If you want to make sure all three pumps are working, go to the Diagnostics screen and run pump outputs.

7. The moisture content displays “LO” or “HI” all the time.

When the moisture content display does not change frequently while baling, there is likely a faulty star wheel connection. One of the first places to check is inside the white star wheel block. Check to see if the electronic swivel is in the star wheel shaft and check to see that the star wheel shaft is not working out of the block. Also, check all star wheel wires and connectors to see if there is a continuity or grounding problem.

8. Should the battery connections be removed before jump starting or charging a battery?

Yes. Anytime the tractor will have voltage going up rapidly the connections should be removed.

MAINTENANCE

1. Clean the tip strainers and main strainer every 10 hours of operation or more frequently if required.
2. Depending on the product being used, the system may need to be flushed with water at a regular interval (consult with manufacturer of the chemical.) If Harvest Tec product is being used, flushing is not necessary.
3. Although the pump can run dry, extended operation of a dry pump will increase wear. Watch the preservative level in the tank.
4. Cover the automatic cab terminal on open station tractors if left outside.
5. Pump performance may start to decline after 400 hours (10000 bales on large square balers) of use. Rebuilding the pump is a simple procedure if the motor is not damaged. Order pump rebuilding kit #007-4581 for the automatic unit.
6. If you are using bacterial inoculants, flush your system daily after every use.
7. Clean tank cap every 10 hours of operation.

Maintenance Schedule

	Daily	10 hrs	400 hrs	Weekly	Monthly	Season
Diagnostics	X					X
Filter bowl cleaning		X				X
Tip screen cleaning		X				X
Tank cap cleaning		X				X
Dielectric grease connections					X	X
Rebuild pump			X			
Battery connections				X		X
Check valves			X			
Visually inspect hoses				X		X

WINTER STORAGE

1. Thoroughly flush the system with water.
2. Remove the filter bowl and run dry until the water has cleared out of the intake side.
3. Remove the red plug from the bottom of the pump, drain, and run the pump for 30 seconds or until it is dry.
4. Drain all lines on the outlet side.
5. Never use oils or alcohol based anti-freeze in the system.
6. For spring start-up, if the pump is frozen, turn off the power immediately to avoid burning the motor out. The pump head can be disassembled and freed or rebuilt in most cases.
7. Disconnect power from the baler mounted processor.
8. Remove display from tractor and store in a warm, dry place.

TROUBLE SHOOTING CHECKS:

<u>PROBLEM</u>	<u>POSSIBLE CAUSE</u>	<u>SOLUTION</u>
Pump will not run.	1. No voltage to Baler Mounted Processor.	1. Check for short, low voltage, and replace fuse if necessary.
	2. Pump locked up.	2. Clean or rebuild pump if motor is OK.
	3. Damaged wire.	3. Repair damaged wire.
Pump runs but will not prime.	1. Air leak in intake.	1. Tighten fittings on intake side.
	2. Clogged intake.	2. Clean.
	3. Restricted outlet.	3. Check and clean tips.
	4. Check valve on outlet stuck closed.	4. Clean or repair check valve.
	5. Dirt inside pump.	5. Replace pump check valve.
Pump does not develop enough output.	1. Air leaks or clogs on inlet side.	1. Tighten or clean filter bowl assembly.
	2. Pump worn or dirty.	2. Rebuild pump.
Moisture reading errors (high or low)	1. Wire disconnected or bad connection between star wheels and baler mounted processor.	1. Reconnect wire.
	2. Low power supply to baler mounted processor.	2. Check voltage at box. (Min of 12 volts required.) See Diagnostics section of manual.
	3. Wet hay over 32% moisture	
	4. Ground contact with one or both star wheels and baler mounted processor.	4. Reconnect.
	5. Short in wire between star wheels and baler mounted processor.	5. Replace wire.
	6. Check hay with hand tester to verify.	6. Contact Harvest Tec if conditions persist.
Moisture readings erratic.	1. Test bales with hand tester to verify that cab monitor has more variation than hand tester.	
	2. Check all wiring connections for corrosion or poor contact.	2. Apply dielectric grease to all connections.
	3. Check power supply at tractor. Voltage should be constant between 12 and 14 volts.	3. Install voltage surge protection on tractors alternator.
Flow meter readings do not match up with product usage.		
Product is less than actual product used.	1. Voltage supplied to meter is less than 6 volts.	1. Check for a min of 6 volts supplied at baler mounted processor.
	2. Wiring short in signal to baler mounted processor.	2. Inspect wire and replace if necessary.
	3. Clog in meter.	3. Back flush with water. DO NOT USE AIR.
	4. Using product other than Harvest Tec	4. Catch and weigh product to check outputs.
Product shown is more than actual product used.	1. High voltage supplied to the meter.	1. Check voltage at baler mounted processor. Max of 18 volts.

	2. Light interference with meter.	2. Reflection into meter can cause a high reading. Move meter or protect from sunlight.
	3. Air leak in intake.	3. Look for air bubbles in line. Replace line or other defective area that is allowing air into the system.
	4. Using product other than Harvest Tec	4. Catch and weigh product to check outputs.
System leaks product out of tips after shut down.	1. Dirty or defective check valves.	1. Clean or Replace.
Terminal reads under or over power.	1. Verify with mult-meter actual voltage. Voltage range should be between 12-14 volts.	1. Clean connections and make sure applicator is hooked to battery. See Diagnostics section of manual.
System always displays "End of Row Pause".	1. Flow meter connector plug is plugged into Hay Indicator port on Baler Mounted Processor.	1. Switch ports.
System does not pause at the end of a row.	1. Short in cable.	1. Replace cable.
Bale rate displays zero.	1. Bale rate sensors are reversed. 2. Short in cable.	1. Switch the sensors next to the star wheel. 2. Replace cable.
Display will not power up.	1. Display connector plug and bale rate sensors plug are switched on the Baler Mounted Processor. 2. Short in display cable.	1. Switch plugs. 2. Replace cable.
Display is too dark or light	1. Change in temperature or light conditions.	1. Use the monitors contrast control.
	2. Display and BMP not communicating.	2. Disconnect 12 volt power cable at hitch. DO NOT DISCONNECT DISPLAY CABLE. Wait 5 minutes and reconnect.
Display says waiting for BMP	1. Display and BMP not communicating.	1. Disconnect 12 volt power cable at hitch. DO NOT DISCONNECT DISPLAY CABLE. Wait 5 minutes and reconnect.

BACKUP FUSE

The Model 465 is equipped with a backup system if your display is not functioning. This function is intended for use only as a temporary means for application and not as a way to apply preservative over multiple fields or for a lengthy amount of time. The baler mounted processor has a location for a backup fuse on the same side as the flow meter and pump harnesses that bypasses all other system inputs and applies preservative using one pump (Pump Three) at a constant lbs/hour shown below. These values are based upon an input voltage of 13.5 DC. Insert at least a 10 amp up to 20 amp fuse (3 AG style) into the backup fuse port to activate the bypass. The system will not turn off or pause until the fuse is removed. The main fuse must also be functional for the backup fuse to work.

	Tip Set	Output (lbs/hour)
465	High	230
	Low	150

WIRING DIAGRAMS

A. Main power connector mounted on battery

Pin 1	Red	+ 12 V input from tractor supply
Pin 2	Black	Ground from tractor supply
Pin 3	Not used	



B. Main power connector mounted on BMP

Pin 1	Red	+ 12 V input from tractor supply
Pin 2	Black	Ground from tractor supply
Pin 3	Not used	

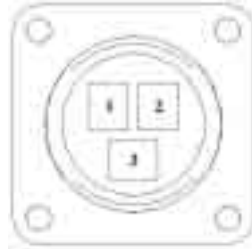

C. Pump connection colors

Pin 1	Black with orange markings	Pump 1 ground
Pin 2	Black with green markings	Pump 2 ground
Pin 3	Black with yellow markings	Pump 3 ground
Pin 4	Not used	
Pin 5	Orange with black markings	Pump 1 positive
Pin 6	Green with black markings	Pump 2 positive
Pin 7	Yellow with black markings	Pump 3 positive

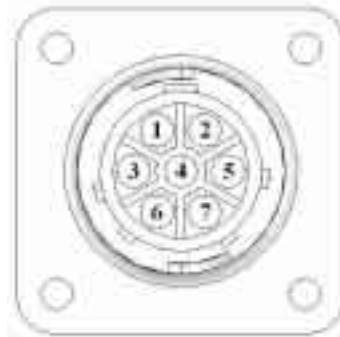

D. Flow meter connection on BMP

Pin 1	White	5 - 12 V (+) supply
Pin 2	Green	Ground
Pin 3	Brown	Signal
Pin 4	Black	Shield



E. Connector for Hay Indicator option on BMP

Note: Hay indicators are an option that will turn the system on and off automatically as hay enters the pickup of the baler.

Pin 1	Red	+12V
Pin 2	Black	Ground
Pin 3	White	Signal wire
Pin 4	Not used	

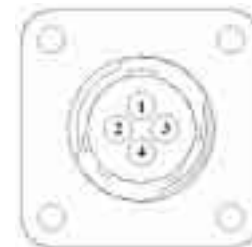

F. Bale rate sensors on BMP

Pin1	Brown	Sensor power
Pin2	Black	Signal for front prox. sensor
Pin3	Blue	Sensor ground
Pin4	Black	Signal for back prox. sensor



G. Star wheel connector mounted on BMP

Pin 1	Brown	Star wheel input 1
Pin 2	Blue	Star wheel input 2
Pin 3	Brown	Diagnostic 1
Pin 4	Blue	Diagnostic 2
Pin 5	Silver	Shield
Pin 6	Silver	Shield
Pin 7	Not used	
Pin 8	Not used	
Pin 9	Not used	



H. Communication harness display to hitch

Pin 1	Red	Power to display
Pin 2	Black	Ground to display
Pin 3	Blue	Comm channel OH
Pin 4	Orange	Comm channel OL

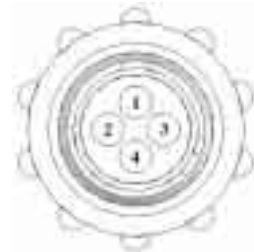

I. Communication harness hitch to baler mounted processor

Pin 1	Red	Power to display
Pin 2	Black	Ground to display
Pin 3	Blue	Comm channel OH
Pin 4	Orange	Comm channel OL



466 PARTS BREAKDOWN CONTROL BOX AND WIRING

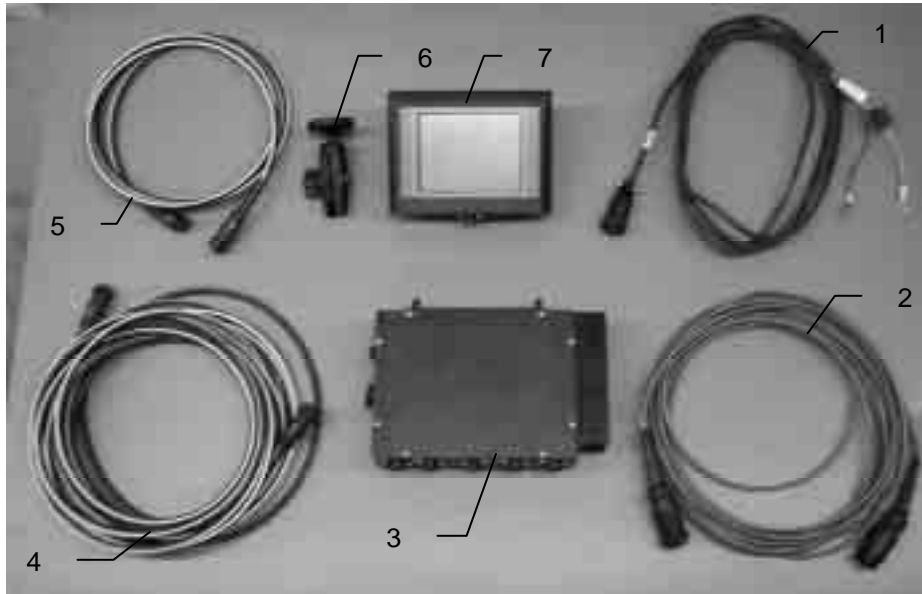

<u>Ref.</u>	<u>Description</u>	<u>Part#</u>
1	Power lead tractor	006-4640A
2	Power lead baler	006-4660K
3	Baler mounted processor	006-4671LS
4	Communication harness (baler)	006-4660L
5	Communication harness (tractor)	006-4660N
6	Ram mount	001-2012H
7	Terminal	006-4670
NP	Hay indicator extension	006-7500A

TIPS

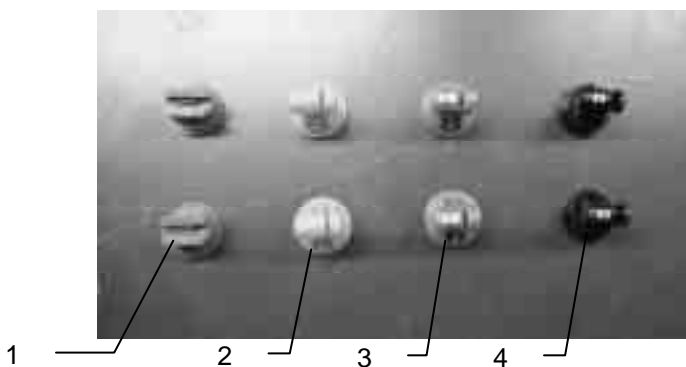

<u>Ref</u>	<u>Description</u>	<u>Part #</u>	<u>Qty</u>
1	Poly Tip	004-80067-PT	2
2	Turbo Tip	004-TT11001VP	2
3	Turbo Tip	004-TT110015VP	2
4	Turbo Tip	004-TT11003VP	2

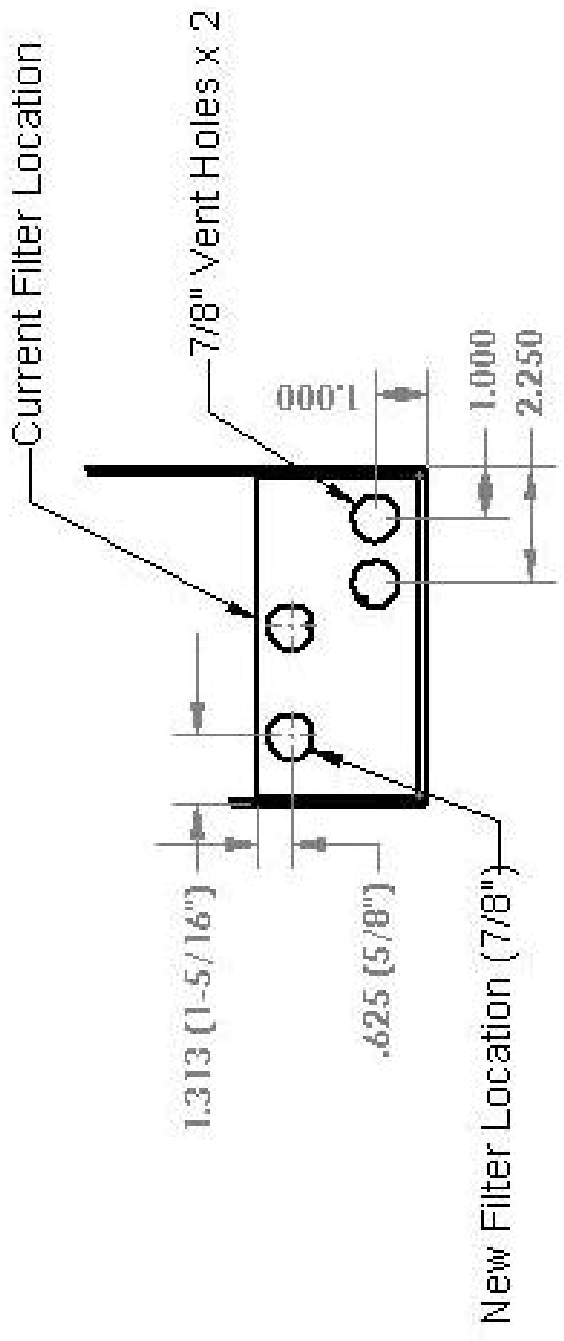
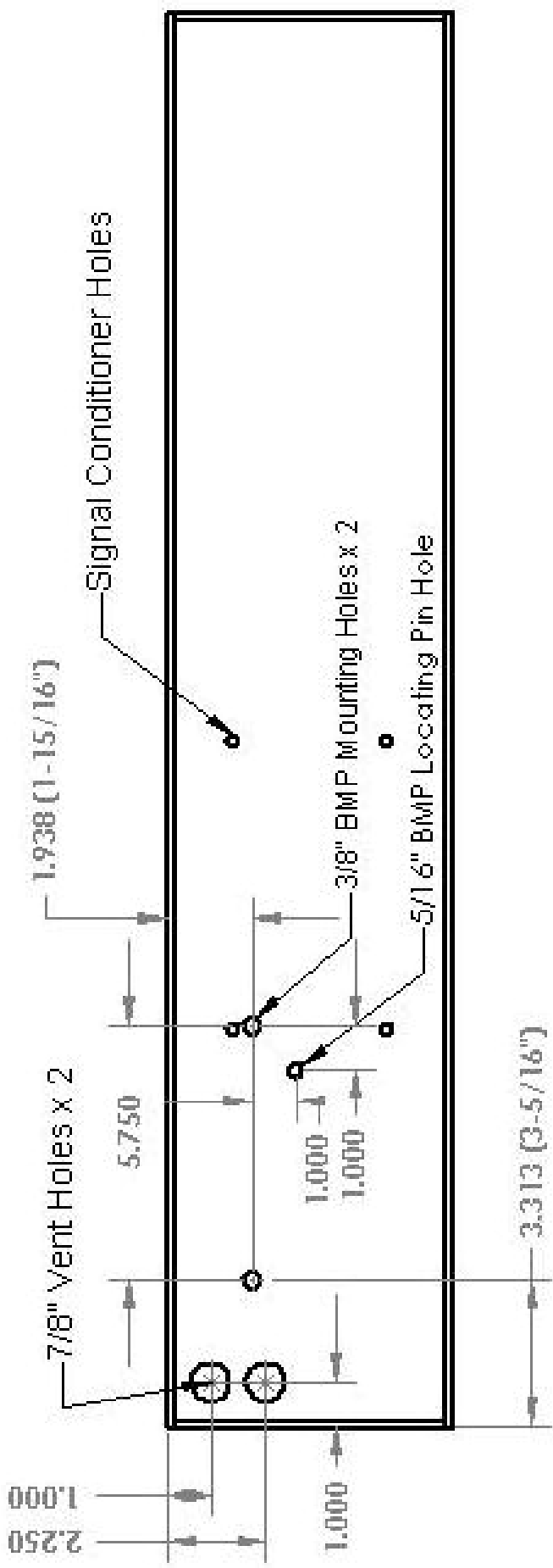

NOTES:

WARRANTY AND LIABILITY AGREEMENT

Harvest Tec, Inc. will repair or replace components that are found to be defective within 12 months from the date of manufacture. Under no circumstances does this warranty cover any components which in the opinion of Harvest Tec, Inc. have been subjected to negligent use, misuse, alteration, accident, or if repairs have been made with parts other than those manufactured and obtainable from Harvest Tec, Inc.

Our obligation under this warranty is limited to repairing or replacing free of charge to the original purchaser any part that in our judgment shows evidence of defective or improper workmanship, provided the part is returned to Harvest Tec, Inc. within 30 days of the failure. Parts must be returned through the selling dealer and distributor, transportation charges prepaid.

This warranty shall not be interpreted to render Harvest Tec, Inc. liable for injury or damages of any kind, direct, consequential, or contingent, to persons or property. Furthermore, this warranty does not extend to loss of crop, losses caused by delays or any expense prospective profits or for any other reason. Harvest Tec, Inc. shall not be liable for any recovery greater in amount than the cost or repair of defects in workmanship.

There are no warranties, either expressed or implied, of merchantability or fitness for particular purpose intended or fitness for any other reason.

This warranty cannot guarantee that existing conditions beyond the control of Harvest Tec, Inc. will not affect our ability to obtain materials or manufacture necessary replacement parts.

Harvest Tec, Inc. reserves the right to make design changes, improve design, or change specifications, at any time without any contingent obligation to purchasers of machines and parts previously sold.

Revised 01/03/06

HARVEST TEC, INC.
P.O. BOX 63
2821 HARVEY STREET
HUDSON, WI 54016
PHONE: 715-386-9100
1-800-635-7468
FAX: 715-381-1792
Email: info@harvesttec.com