

# Installation Manual

***Model 600A1***

***Moisture Sensor Kit for Large Square Balers***



**HayBoss™**  
**G2**



**DECLARATION OF APPLICATION OF ESSENTIAL REQUIREMENTS OF THE DIRECTIVE 2006/42/ EC OF THE EUROPEAN PARLIAMENT AND OF THE COUNCIL OF 17, MAY, 2006 AND OTHER RELEVANT EU DIRECTIVES:** The Harvest Tec Hay Moisture Sensor Kit conforms with the Directive and other relevant EU directives.

**SERVICE DUTY OF THE PARTIALLY COMPLETED MACHINE:** The Harvest Tec Hay Moisture Sensor Kit will only be put into service after installed on a hay baler that has been declared to conform with the Directive.

Noise from the Harvest Tec Moisture Sensor Kit does not exceed 70 dB (A).

**Manufacturers Name Plate**

<b>Harvest Tec Inc.</b> Manufactured at and correspondence to: 2821 Harvey Street Hudson, WI 54016 USA	
<b>Model</b>	
<b>Build Date</b>	
<b>Serial No.</b>	

**PERSON AUTHORIZED TO PROVIDE INFORMATION ON THE MACHINE AND WHO MAKES THIS DECLARATION:**

**Jeffery S. Roberts, President, Harvest Tec, Inc.**

Signed in Hudson, WI, USA on May 21, 2011

# 600A1 Installation Manual Table of Contents

	<u>PAGE</u>
<b>Introduction</b>	<b>3</b>
<b>System Requirements</b>	<b>4</b>
<b>Tools Needed</b>	<b>4</b>
<b>Safety</b>	<b>4</b>
<b>Safety Signs</b>	<b>4</b>
<b>Installing the 600A1 Moisture Sensor Kit</b>	<b>5-8</b>
Mount the Dual Channel Processor (DCP)	5
Installing Star Wheels	6
Wiring Installation	7
Connecting the Star Wheels to DCP	8
Connecting the Harnesses to the DCP	8
<b>Parts Breakdown</b>	<b>9-10</b>
Controls and Harnesses	9
Star Wheel Sensors	10
<b>Warranty Statement</b>	<b>11</b>

## Introduction

Thank you for purchasing the 600A1 Moisture Monitor System. This system is designed to monitor the moisture of the forage crop and to plug directly into the baler's ISOBUS and display on a C1000 monitor. The 600A1 Moisture Monitor System offers these advantages:

1. Operation coordinated with baler operation
2. Records kept together
3. Less cab clutter providing better visibility
4. And the system is ready for future updates.
5. Ease of use with all information on one screen

The 600A1 Moisture Monitor kit includes the following parts: Dual Channel Processor (DCP), Moisture Sensors, Harnesses and Miscellaneous Hardware. For your convenience a parts break down for the model 600A1 is included in the back of this manual. If you do have questions bring this manual into the dealership. They can assist you in ordering the correct replacement parts.

The 600A1 Moisture Monitoring System can have a complete preservative applicator added as well as the tagging option to enhance the system at any time. Contact your local dealer for more information.

Right and Left sides are determined by facing in the direction of forward travel.

## System Requirements

The Baler Processor must have Version 3.3 or higher.

### Tools Needed:

- Standard wrench set
- Electric drill and bits
- Side cutter
- Standard nut driver set
- Standard socket set
- Hammer & Center Punch

### Safety

Carefully read all safety signs in this manual and on the moisture sensor kit before use. Keep signs clean and clear of obstruction to view. Replace missing or damaged safety signs. Replacement signs are available from your local authorized dealer. See your installation manual under the replacement parts section for the correct part numbers.

Keep your moisture sensor kit in proper working condition. Unauthorized modifications to the moisture sensor kit may impair the function and/or safety of the machine.

Carefully read and understand all safety signs before installing or servicing.

### Safety Signs

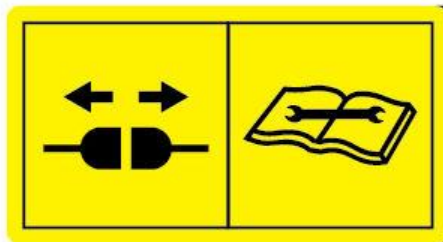

Number 1  
Disconnect power before servicing.  
Part no. DCL-8003



Number 2  
Read and understand the operator's manual before  
using or working around the equipment.  
Part no. DCL-8000

## Installing the 600A1 Moisture Sensor Kit

### Mounting the Dual Channel Processor (DCP)

Locate the Dual Channel Processor (006-6671LS), four 5/16" x 1" hex bolts, flats, locks and nuts. Mark, and drill four 3/8" (9.525 mm) holes following the template shown below. The whip wire extension on the DCP should be facing down when attached to the baler. Mount the DCP cover (001-5650X) over the DCP and secure the hardware.

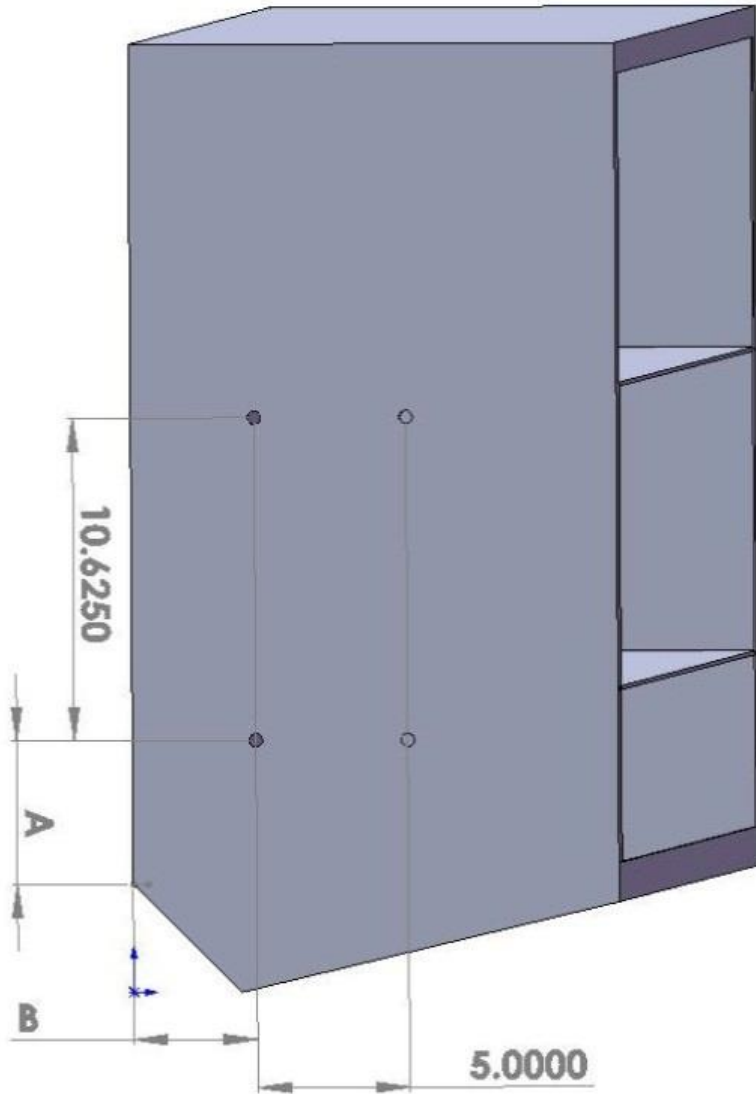

A = 12" (304.80mm)  
B = 3" or (76.200mm)

10.62 inches = 270mm

5.00 inches = 127mm

## Installing Star Wheels

The star wheel block has a plug on one side and a wire grommet on the other side. If there is interference or problems with the star wheel wires on one side of the block, exchange the wire grommet with the plug so the wire can exit the block on the opposite side. Mount the twine guards using the two inner holes on the star wheel block.

The star wheels are to be mounted on top of the baler just behind the knotters and under the walkway on both sides. The notch and holes for the star wheels are pre-cut. Place the spacer plate (001-6707E) over the pre-cut holes. Attach with 5/16" x 1/2" Allen head bolts and internal star washers from inside the bale chamber. Center the star wheels over the top of the spacer plate, place the twine diverters on top of the star wheel and attach with 5/16" x 2-1/4" hex bolt and lock washers. For remaining two holes of each star wheel attach with 5/16" x 2-1/4" hex bolt, lock washer, and one 5/16" thick flat washer per bolt. Verify the star wheels align with bale chamber before tightening all hardware. **(The twine guard with the two additional holes should be placed on the right side of the baler looking from the rear).**

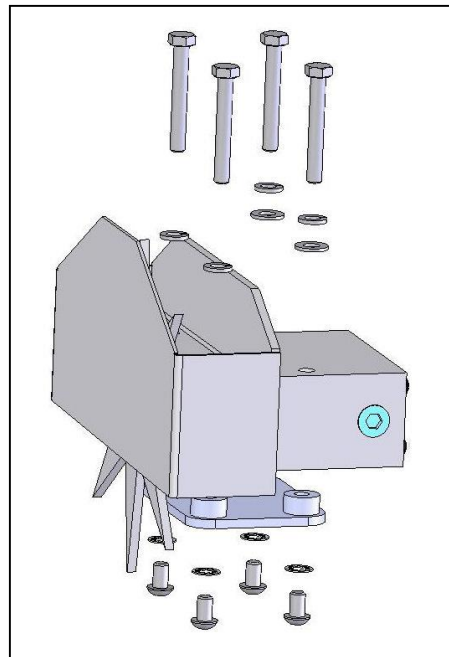
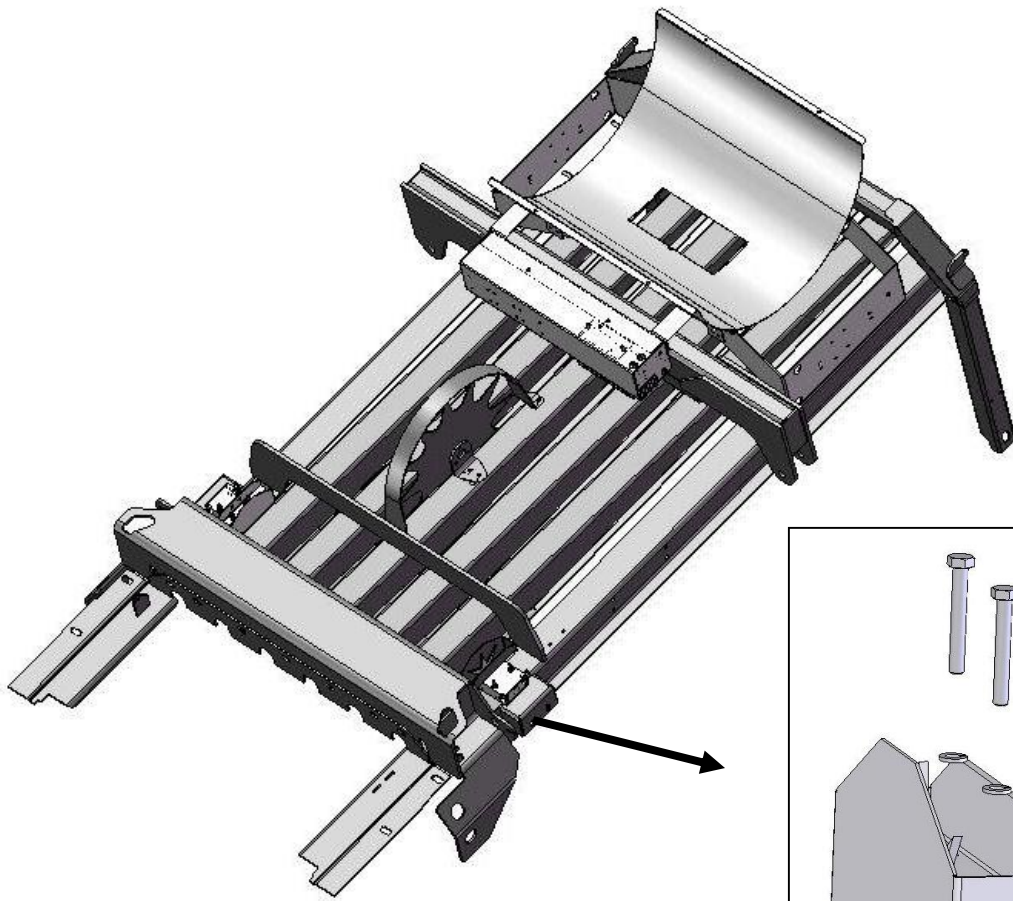

## Wiring Installation

### Connecting to the Baler Harness



Locate the communication harness (006-6650VC) and the connection point shown (Left) on baler.

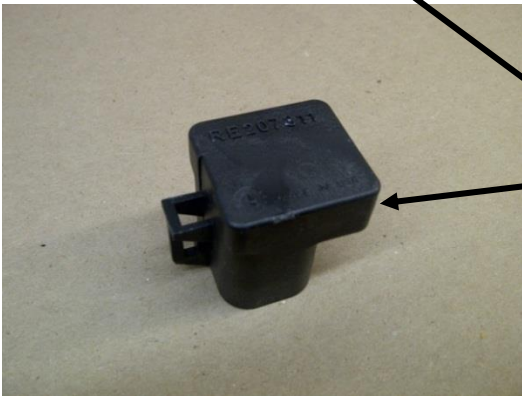

Under the chamber locate the Active Terminator from the end of the baler harness. It is located at the right rear corner of the baler frame. Attach Baler Interface Harness (006-6650VC) to that location. Reconnect Active Terminator to open port of that same harness (006-6650VC). If your baler does not have a Terminator at this location see further instructions below.

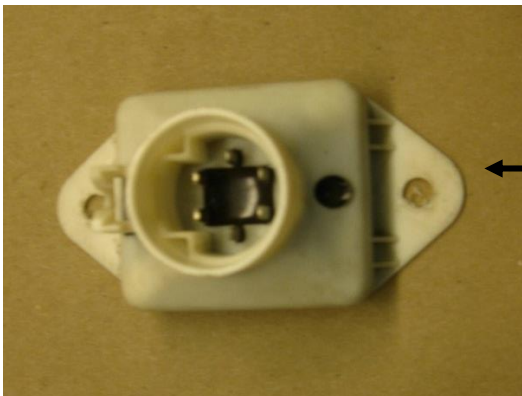

If your baler has the White Terminating Resistor you will need to attach the Pre 2012 AGCO Integration Harness (006-6650VAX) to the end of the Baler Interface harness (006-6650VC). Please contact Harvest Tec for this harness. This style terminator may be next to the Baler's Main Processor.

Be sure to mount and secure all harnesses away from hydraulic lines and moving parts.

## Connecting the Star Wheels to the DCP



Locate the moisture harness (006-4640E2). Remove the four pan head screws on each star wheel and loosen the grommet. Insert the eye loop of the wire into the star wheel block and install on the end of the swivel. Leave a loop in the wire to allow the star wheel cover space to be reinstalled. Tighten the swivel nut, followed by the grommet, and finally install and tighten the four screws. The picture to the right shows the star wheel block open with the wire looped and attached to the swivel. Once both wheels are complete route the harness towards the DCP on the back right twine box. Be sure to mount and secure all harnesses away from hydraulic lines and moving parts.

## Connecting the Harnesses to the DCP

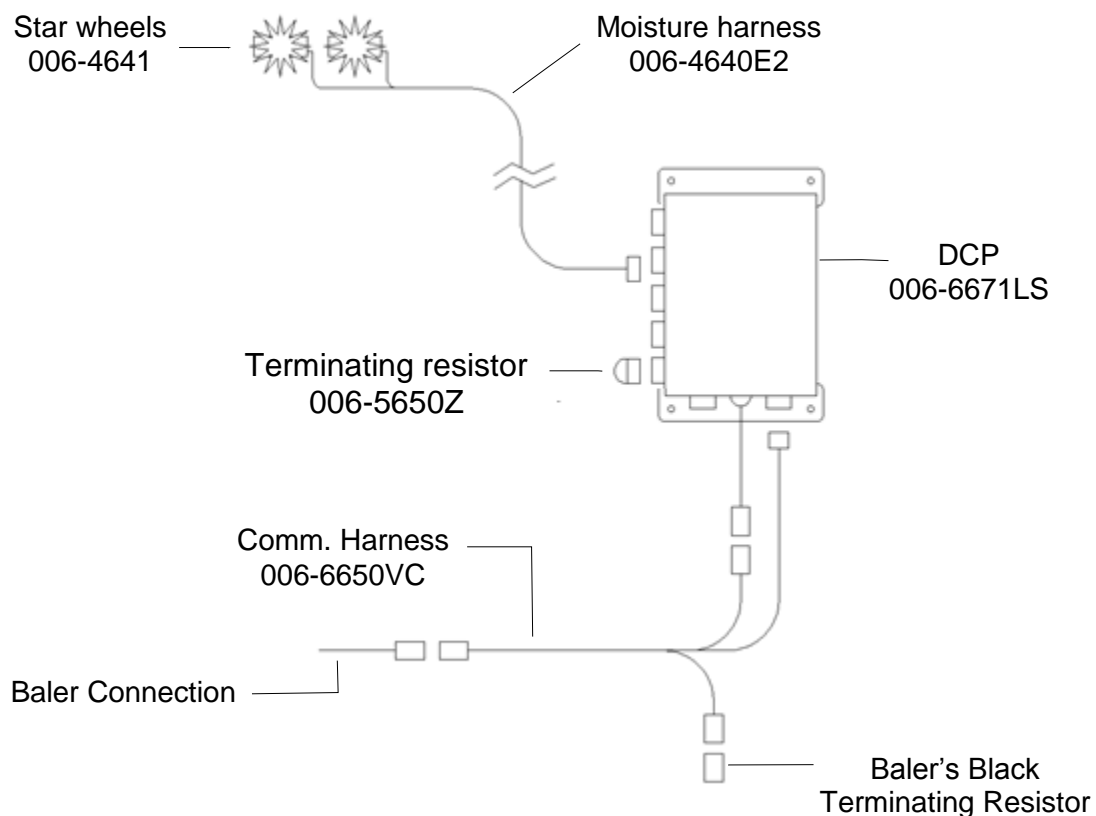

1. Install the green capped terminating resistor (006-5650Z) to the Dual Channel Processor (DCP).
2. Route the communication harness (006-6650VC) from the baler to the DCP. Attach the harness to the whip harness coming off the base of the DCP. Secure harness from DCP to baler communication port.
3. Install the baler's black terminating resistor to the open end of the communication harness (006-6650VC) next to the DCP.
4. Install the moisture harness (006-4640E2) into the DCP at the port marked Moisture Sensor. Secure harness from DCP to star wheels.



## Controls and Harnesses



<u>Ref #</u>	<u>Description</u>	<u>Part #</u>	<u>Qty</u>	<u>Ref #</u>	<u>Description</u>	<u>Qty</u>
1	Star wheel spacer	001-6707E	2	10	5/16" nuts	22
2	Star wheels	030-4641	2	10	5/16" lock washers	14
3	Moisture harness	006-4640E2	1	10	5/16" flat washer	4
4	DCP cover	001-5650X	1	11	10/24 x 5/8" PHS	8
5	Dual Channel Processor	006-6671LS	1	11	10/24 lock washers	8
6	Comm. harness	006-6650VC	1	12	5/16" x 1/2" BHCS	8
7	Wire clips	008-9018	9	13	5/16" x 2-1/4" hex bolt	8
8	Twine diverter	001-4645H	1	14	5/16 x 1" hex bolt	4
9	Twine diverter	001-4644H	1	15	12" cable ties	5
NP	Terminating resistor	006-5650Z	1			

## Star Wheel Sensors

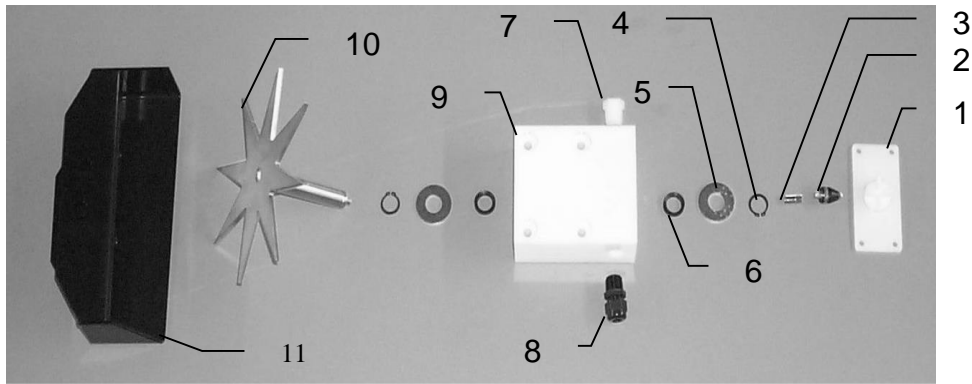

<u>Ref #</u>	<u>Description</u>	<u>Part#</u>	<u>Qty</u>	<u>Ref #</u>	<u>Description</u>	<u>Part#</u>	<u>Qty</u>
1	Block cover	006-4641B	2	9	Star wheel block	006-4641A	2
2	Electronic swivel	006-4642A	2	10	Star wheel sensor	030-4641C	2
3	Swivel insert	w/ Ref # 10	2	11	Twine guard-left for Agco	001-4645H	1
4	Snap ring (per side)	006-4641K	2		Twine guard-Right for Agco	001-4644H	1
5	Washer (per side)	w/006-4641K	2	1-10	Star wheel assembly	030-4641	2
6	Dust seal (per side)	w/006-4641K	2	12	Spacer plate for Agco	001-6707E	2
7	Plug fitting	003-F38	2				
8	Wiring grommet	008-0821A	2				

## **WARRANTY AND LIABILITY AGREEMENT**

Harvest Tec, Inc. will repair or replace components that are found to be defective within 12 months from the date of manufacture. Under no circumstances does this warranty cover any components which in the opinion of Harvest Tec, Inc. have been subjected to negligent use, misuse, alteration, accident, or if repairs have been made with parts other than those manufactured and obtainable from Harvest Tec, Inc.

Our obligation under this warranty is limited to repairing or replacing free of charge to the original purchaser any part that in our judgment shows evidence of defective or improper workmanship, provided the part is returned to Harvest Tec, Inc. within 30 days of the failure. Parts must be returned through the selling dealer and distributor, transportation charges prepaid.

This warranty shall not be interpreted to render Harvest Tec, Inc. liable for injury or damages of any kind, direct, consequential, or contingent, to persons or property. Furthermore, this warranty does not extend to loss of crop, losses caused by delays or any expense prospective profits or for any other reason. Harvest Tec, Inc. shall not be liable for any recovery greater in amount than the cost or repair of defects in workmanship.

There are no warranties, either expressed or implied, of merchantability or fitness for particular purpose intended or fitness for any other reason.

This warranty cannot guarantee that existing conditions beyond the control of Harvest Tec, Inc. will not affect our ability to obtain materials or manufacture necessary replacement parts.

Harvest Tec, Inc. reserves the right to make design changes, improve design, or change specifications, at any time without any contingent obligation to purchasers of machines and parts previously sold.

Revised 01/13

**HARVEST TEC, INC.**  
**P.O. BOX 63**  
**2821 HARVEY STREET**  
**HUDSON, WI 54016**  
PHONE: 715-386-9100  
1-800-635-7468  
FAX: 715-381-1792  
Email: [info@harvesttec.com](mailto:info@harvesttec.com)