

# Installation Manual

## ***Model 696*** ***100 & 110 Gallon Preservative Applicator***



---

P.O. Box 63 • 2821 Harvey Street • Hudson, WI 54016  
800-635-7468 • [www.harvesttec.com](http://www.harvesttec.com)

(intentionally blank)

# Harvest Tec Model 696 Installation Table of Contents

	<u>PAGE</u>
<b>Introduction</b>	<b>5</b>
<b>System Requirements</b>	<b>5</b>
<b>Installation Kit Reference Chart</b>	<b>5-6</b>
<b>Tools Needed</b>	<b>6</b>
<b>Installation of Applicator</b>	<b>7-45</b>
<b>Installation of Pump Manifold</b>	<b>7-10</b>
Hesston, New Idea, Challenger, Massey Ferguson & CASE IH 8570, 8575, 8580, 8585, & 8590 Balers	7
Case IH & New Holland	8
Claas, John Deere, Vermeer, & Krone Balers	9
Kuhn, Vicon, & Taarup balers	10
Claas 3200 – 3400 Large Square Balers	11
<b>Installation of Dual Channel Processor (DCP)</b>	<b>12</b>
<b>Installation of Tank and Star Wheels</b>	<b>13-21</b>
New Holland 590 - BB 9080 & Case IH LBX331 through LB433 Baler	14
Case IH 8570, 8575, & 8585, Challenger LB33, LB34, & Hesston 7430, 4750, 4755, 4760, 4790, & Massey Ferguson 2050, & New Idea 7233, 7333, & 7234 Balers	15
Case IH 8580, 8590 & Hesston 4900, 4910 & Challenger LB 44 & New Idea 7244	16
Vermeer Balers	17
Claas 2100 & 2200 Balers	18
Claas 3200-3400 Large Square Balers	18-19
Krone Balers	20
Kuhn 870 – 1290, Vicon LB 8200 & LB 12200 balers & Taarup 6570 – 6690 OC	21
<b>Installation of End of Bale Sensor (EOB)</b>	<b>22-32</b>
Hesston 4760, 4750-4755, 4790 & 4900-4910	22
Krone 890 – 12130	23
All Kuhn, Vicon & Taarup Balers	23
<b>EOB Installation Diagram</b>	<b>24-32</b>
Hesston 4750-4755 & 4900-4910	24
Heston 4760 & 4790	25
New Holland 590-BB960, BB9060-BB9080 & Case IH LBX 331-431, LB333-LB433	26
New Holland BB940A-BB960A & Case IH LBX 332-432	27
Claas 2100	28
John Deere 100	29
Krone 890 – 1290	30
Krone 12130	31
All Kuhn, Vicon and Taarup Balers	32
<b>Installation of Drain/Fill Line</b>	<b>33</b>
<b>Installation of Spray Shield</b>	<b>34-46</b>
High /Low Tip Output Rates	34
Installation kit 4438B	34
Installation kit 4439B & 4490B	35
Installation kit 4491B & 4492B	36
Installation kit 4494B, 4495B & 4528B	37
Installation kit 4497B & 4529B	38
Installation kit 4498B	38
Installation kit 4499B & 4500B	39
Installation kit 4501B & 4509B	40

## Table of Contents (continued)

	<u>PAGE</u>
Installation kit 4510B & 4511B	41
Installation kit 4514B & 4515B	42
Installation kit 4525B	43
Installation kit 4537B	44
Installation kit 4539B	45
Installation kit 4540 & 4541B	45
<b>Plumbing</b>	<b>46</b>
High/Low Tip Selection, Hose Color, Pump Position	46
<b>Installation of Star Wheel and Bale Rate Harness</b>	<b>46</b>
Wiring Main Power /Communication Harness to Baler Terminator Connection	47
<b>Installation of Bluetooth Receiver</b>	<b>47</b>
<b>Connecting optional ISOBUS Plug to Tractor</b>	<b>47</b>
<b>Wiring Diagram</b>	<b>48</b>
<b>Pin Outs</b>	<b>49-51</b>
<b>Parts Breakdown</b>	<b>52-82</b>
Tank, Saddle and Saddle Legs	52-54
Pump Manifold	55
Star Wheel Moisture Sensor	56
Controls and Harnesses	57
Hose and Drain Fill Line	58
Optional iPad Mini Mounting Kit	59
Optional iPad Display Kit	60
Model Specific Installation Kits	60-82
Installation kit 4438B	61
Installation kit 4439B	62
Installation kit 4490B	63
Installation kit 4491B	64
Installation kit 4492B	65
Installation kit 4494B	66
Installation kit 4495B & 4528B	67
Installation kit 4497B & 4529B	68
Installation kit 4498B	69
Installation kit 4499B	70
Installation kit 4500B	71
Installation kit 4501B	72
Installation kit 4509B	73
Installation kit 4510B	74
Installation kit 4511B	75
Installation kit 4514B	76
Installation kit 4515B	77
Installation kit 4525B	78
Installation kit 4537B	79
Installation Kit 4539B	80
Installation Kit 4540B	81
Installation Kit 4541B	82
Vicon Star Wheel Install Template	83
Star Wheel Install Template	84
<b>Notes</b>	<b>85-86</b>
<b>Warranty Statement</b>	<b>87</b>



## Introduction

Thank you for purchasing a Harvest Tec Model 696 Hay Preservative Applicator. This 696 applicator system has been designed to be operated through an Apple iPad (not included) using the Hay App. As well as the option to plug directly into most tractors that have an ISOBUS Monitor. The 696 Applicator System offers these advantages by operating through an Apple iPad:

1. Large bright, clear, colorful display
2. More durable and can be read in bright sunlight
3. Wireless connection in cab
4. Can be used for multiple other uses than just the applicator display
5. Option to tie-into the tractor ISOBUS system

The 696 Hay Preservative Applicator System is designed to apply buffered propionic acid to the forage crop as it is baled and will adjust the rate of application based on moisture and tonnage of the crop being harvested. The model 696 base kit includes: tank, frame, pumps, hose, and the Dual Channel Processor (DCP). This manual will take you through the steps for installing the applicator. If you are unsure about installing the system after consulting this manual, contact your local authorized dealership for additional assistance. If you are in need of parts for the system please see the parts breakdown in the back of this manual and contact your local authorized dealer to order the parts. This applicator is designed to apply Harvest Tec buffered propionic acid.

Right and Left sides are determined by facing in the direction of forward travel.

**\*Requirement to run iPad option are 3<sup>rd</sup> Generation iPad (2012) or newer with iOS8 or greater operating system, plus the Hay App.**

*If choosing to operate the unit through the ISOBUS monitor, part number 006-6670A will need to be ordered through your local equipment dealer.*

### Attention:

For kits on 2010 Krone HDP balers and newer Krone part number 20 073 194 0 must be ordered to mount the star wheels.

Please see attached supplemental manual for further instructions.

### Installation Kit Reference Chart

BALER MAKE	MODEL	INSTALL KIT
<b>AGCO</b>	4750 – 4755	030-4490B
<b>Hesston</b>	4760	030-4494B
	4790	030-4492B
	4900 – 4910	030-4491B
	4760 roto-cutter	030-4500B
	4790 roto-cutter	030-4501B
	7430	030-4494B
	7430 roto-cutter	030-4500B
	<b>Case IH</b>	8570 – 8575
8585		030-4492B
8580 - 8590		030-4491B
LBX331 – 332 STD or packer		030-4495B
LBX431 – 432 STD or packer		030-4495B
LBX331 – 332 roto-cutter		030-4497B
LBX431 – 432 roto-cutter		030-4497B
LB333 – 433 STD or packer		030-4495B
LB333 – 433 roto-cutter		030-4497B
LB 433 STD or packer (2011-2012)		030-4528B
LB 433 roto-cuter (2011-2012)		030-4529B

<b>Challenger</b>	LB33	030-4494B
	LB34	030-4492B
	LB44	030-4491B
<b>Claas</b>	2200/1200/3200/3400	030-4499B
	2100	030-4509B
	3300	030-4537B
<b>Krone</b>	VFS 88	030-4498B
	VFS 88 cutter	030-4495B
	VFS 128	030-4498B
	VFS 128 cutter	030-4495B
	890-12130 XC	030-4514B
	890-12130	030-4515B
	BP 4x4, BP 4x4 HS	030-4539B
	890 XC High Speed	030-4540B
1270,1290, 1290HDP, 4x4 XC HS	030-4541B	
<b>Kuhn</b>	LSB 870 – 890	030-4510B
	LSB 1270 – 1290	030-4511B
	Omni-cut	030-4525B
<b>Massey</b>	2050	030-4494B
<b>Ferguson</b>	2050 roto-cutter	030-4500B
<b>New Idea</b>	7233	030-4490B
	7234	030-4492B
	7244	030-4491B
	7333	030-4494B
<b>New Holland</b>	590-BB9080 STD or packer	030-4495B
	BB940-BB9080 roto-cutter	030-4497B
	BB9080 STD or packer (2011-2012)	030-4528B
	BB9080 roto-cutter (2011-2012)	030-4529B
<b>Taarup</b>	6570 – 6570 OC	030-4510B
	6670 – 6690 OC	030-4511B
<b>Vermeer</b>	SQ2731	030-4438B
	SQ3347	030-4439B
<b>Vicon</b>	LB 8200	030-4510B
	LB 12200	030-4511B

#### Tools Needed:

- Standard wrench set
- Electric drill and bits
- Side cutter
- Crescent wrench
- Standard screwdriver
- Center punch
- Standard nut driver set
- Standard socket set
- Hammer
- Metal cutting tools
- Hose cutter

## Installation of Applicator

### Installation of Pump Manifold

Hesston, New Idea, Challenger, and Case 8570, 8575, 8580, 8585, 8590 Balers:

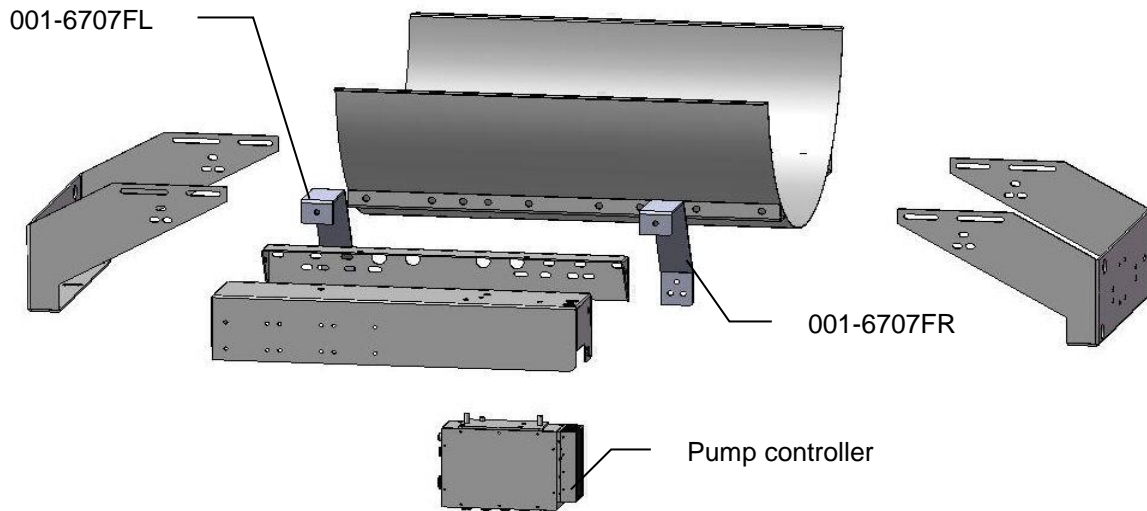

### 3 X 3 balers only

Locate parts bag 2. Install both saddle legs (001-6707C) onto the saddle (001-6707A) with eight 3/8" x 1-1/4" Bolts, locks and flat washers. Note: the slots in the legs will attach to the second and fourth weld nuts in from each end, of the saddle, on both sides.

1. Once legs and saddle are loosely attached measure the distance from the top outside corners of the bale chamber where the saddle will be attached. Move legs in or out so the outside edges will match this dimension. Also try to center the saddle within these dimensions. Do not fully tighten bolts until mounted on the baler
2. Locate parts bag 6. Mount the pump plate support legs (001-6707FL & 001-6707FR) to the saddle legs using six 3/8" x 1" bolts, locks, flats, and nuts. Note: this will be the side that is opposite of the "V" notch that is in the sump cut out of the saddle
3. Attach the pump plate mounting bracket (001-4646C) to the pump plate support legs with two 3/8" x 1-1/4" bolts, locks, flats, and nuts.
4. Attach the pump plate holder (001-4646D) to the pump plate mounting bracket (001-4646C) using four 3/8" x 3/4" flange head bolts

### 3 X 4 and 4 x 4 balers only

Locate parts bag 2. Install both saddle legs (001-6707C) onto the saddle (001-6707A) with eight 3/8" x 1-1/4" Bolts, locks and flat washers. Note: the slots in the legs will attach to the first and second weld nuts in from each end, of the saddle, on both sides.

1. Once legs and saddle are loosely attached measure the distance from the top outside corners of the bale chamber where the saddle will be attached. Move legs in or out so the outside edges will match this dimension. Also try to center the saddle within these dimensions. Do not fully tighten down bolts until mounted on the baler.
2. Locate parts bag 6. Mount the pump plate support legs (001-6707FL & 001-6707FR) to the saddle legs using six 3/8" x 1" bolts, locks, flats, and nuts. Note: this will be the side that is opposite of the "V" notch that is in the sump cut out of the saddle
3. Attach the pump plate mounting bracket (001-4646C) to the pump plate support legs with two 3/8" x 1-1/4" bolts, locks, flats, and nuts.
4. Attach the pump plate holder (001-4646D) to the pump plate mounting bracket (001-4646C) using four 3/8" x 3/4" flange head bolts

**The Pump Controller and pump heads must be pointing down. Failure to mount the pump plate assembly in this specified direction will void all warranty of the Pump Controller and pumps.**

## Case IH & New Holland

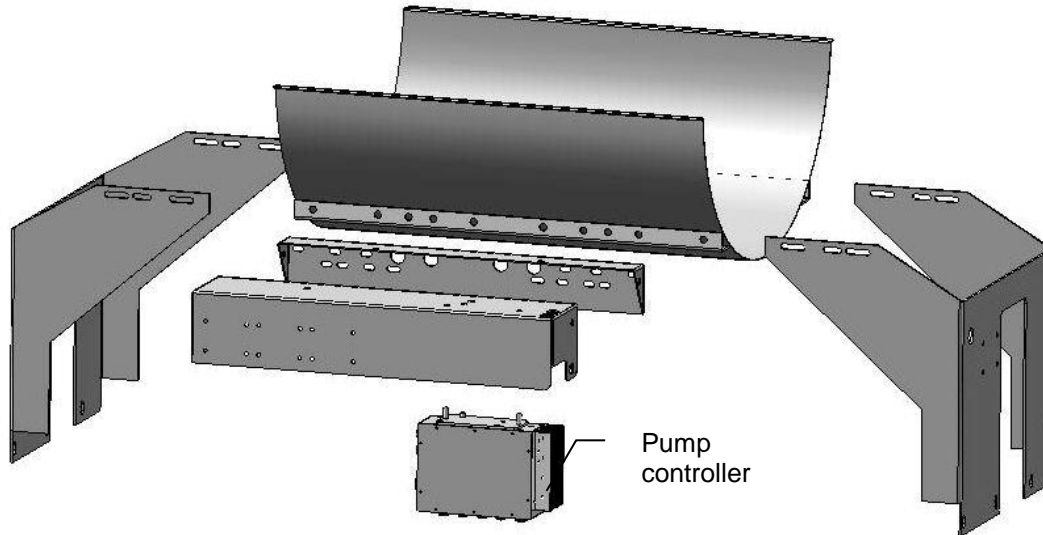

### 3 X 3 balers only

Locate parts bag 2. Install both saddle legs (001-6707BL & 001-6707BR) onto the saddle (001-6707A) with six 3/8" x 1-1/4" bolts, locks and flat washers. The mounting slots in the legs will attach to the second and fourth weld nuts in from each end, of the saddle, on both sides. Note: There is a "V" shape cut out in the sump area of the saddle. This side of the saddle should be attached to the side of the legs that have a narrower profile.

1. Once legs and saddle are loosely attached measure the distance from the top outside corners of the bale chamber where the saddle will be attached. Move legs in or out so the inside edges will match this dimension. Also try to center the saddle within these dimensions. Do not fully tighten down bolts until unit is mounted on the baler.
2. Connect the pump plate mounting bracket (001-4646C) to the side of the saddle that has the wider profile to the legs. Using two 3/8" x 1-1/4" bolts, lock & flat washers.
3. Attach the pump plate holder (001-4646D) to the pump plate mounting bracket (001-4646C) using four 3/8" x 3/4" flange head bolts

### 3 X 4 balers only

Install both saddle legs (001-6707DL & 001-6707DR) onto the saddle (001-6707A) with six 3/8" x 1-1/4" Bolts, locks and flat washers. The mounting slots in the legs will attach to the first and second weld nuts in from each end, of the saddle, on both sides. Note: There is a "V" shape cut out in the sump area of the saddle. This side of the saddle should be attached to the side of the legs that have a narrower profile.

1. Once legs and saddle are loosely attached measure the distance from the top outside corners of the bale chamber where the saddle will be attached. Move legs in or out so the inside edges will match this dimension. Also try to center the saddle within these dimensions. Do not fully tighten down bolts until unit is mounted on the baler
2. Connect the pump plate mounting bracket (001-4646C) to the side of the saddle that has the wider profile to the legs. Using two 3/8" x 1-1/4" bolts, lock & flat washers.
3. Attach the pump plate holder (001-4646D) to the pump plate mounting bracket (001-4646C) using four 3/8" x 3/4" flange head bolts

**The Pump Controller and pump heads must be pointing down. Failure to mount the pump plate assembly in this specified direction will void all warranty of the Pump Controller and pumps.**

## Claas, John Deere 100, Vermeer, and Krone Balers

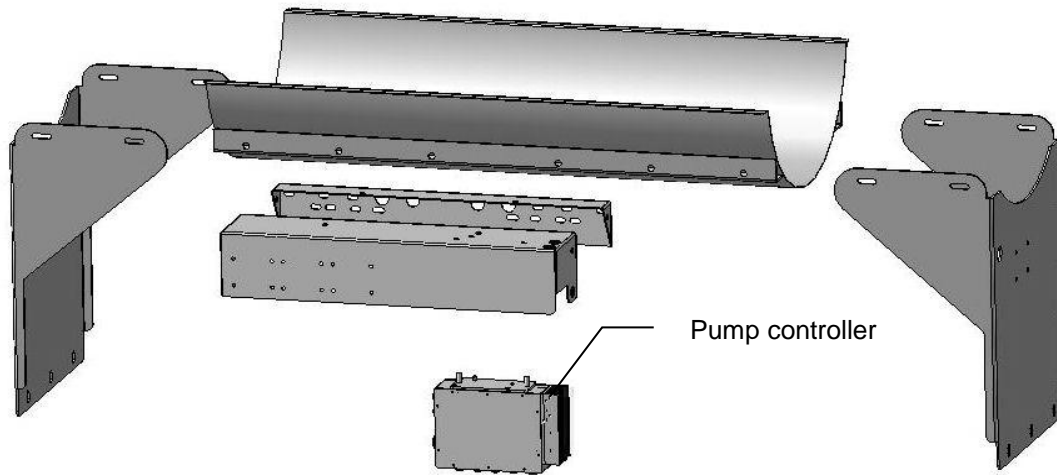

### 3 X 3 balers only

Locate parts bag 3. Install both saddle legs (001-6706V) onto the saddle (001-6706A) with six 3/8" x 1-1/4" bolts, locks and flat washers. The mounting slots in the legs will attach to the second and third weld nuts in from each end, of the saddle, on both sides.

1. Once legs and saddle are loosely attached measure the distance from the top outside corners of the bale chamber where the saddle will be attached. Move legs in or out so the inside edges will match this dimension. Also try to center the saddle within these dimensions. Do not fully tighten down bolts until unit is mounted on the baler.
2. Connect the pump plate mounting bracket (001-4646C) to the saddle. Using two 3/8" x 1-1/4" bolts, lock & flat washers. Note: this will be the side that is opposite of the "V" notch that is in the sump cut out of the saddle.
3. Attach the pump plate holder (001-4646D) to the pump plate mounting bracket (001-4646C) using four 3/8" x 3/4" flange head bolts.

### 3 X 4 and 4 x 4 balers only

Locate parts bag 3. Install both saddle legs (001-6706V) onto the saddle (001-6706A) with six 3/8" x 1-1/4" bolts, locks and flat washers. The mounting slots in the legs will attach to the first and second weld nuts in from each end, of the saddle, on both sides.

1. Once legs and saddle are loosely attached measure the distance from the top outside corners of the bale chamber where the saddle will be attached. Move legs in or out so the inside edges will match this dimension. Also try to center the saddle within these dimensions. Do not fully tighten down bolts until unit is mounted on the baler.
2. Connect the pump plate mounting bracket (001-4646C) to the saddle. Using two 3/8" x 1-1/4" bolts, lock & flat washers. Note: this will be the side that is opposite of the "V" notch that is in the sump cut out of the saddle.
3. Attach the pump plate holder (001-4646D) to the pump plate mounting bracket (001-4646C) using four 3/8" x 3/4" flange head bolts.

The Pump Controller and pump heads must be pointing down. Failure to mount the pump plate assembly in this specified direction will void all warranty of the Pump Controller and pumps

\*If the applicator is being mounted onto a **Krone 870 HDP** baler, two leg adapter brackets will be needed for proper tank leg installation (right). Part number 001-6707KV

Contact your dealership for details.

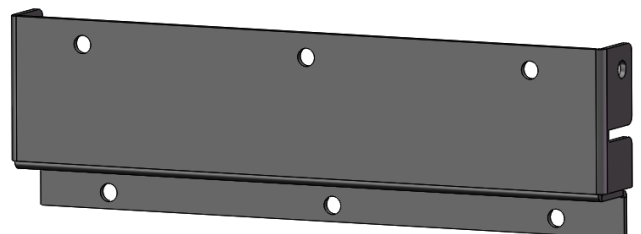

## Kuhn, Vicon & Taarup Balers

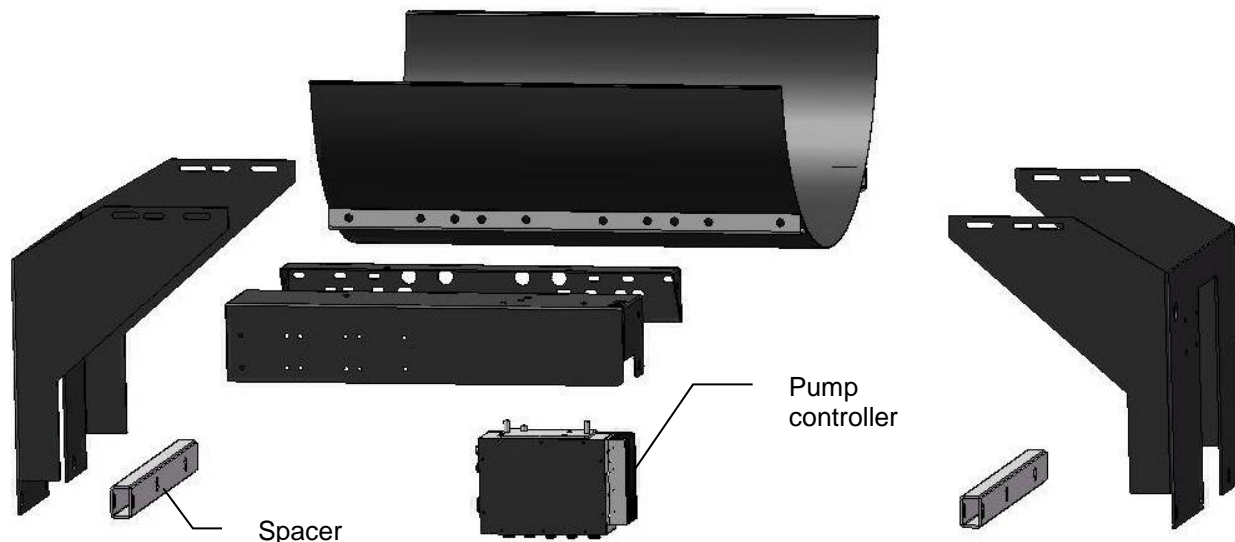

### 3 X 3 balers only

Locate parts bag 4. Install both saddle legs (001-6707BL & 001-6707BR) onto the saddle (001-6707A) with six 3/8" x 1-1/4" Bolts, locks and flat washers. The mounting slots in the legs will attach to the second and fourth weld nuts in from each end, of the saddle, on both sides. Note: There is a "V" shape cut out in the sump area of the saddle. This side of the saddle should be attached to the side of the legs that have a narrower profile.

1. Once legs and saddle are loosely attached measure the distance from the top outside corners of the bale chamber where the saddle will be attached. Move legs in or out so the inside edges will match this dimension. Also try to center the saddle within these dimensions. The spacers (001-6707BS) will be needed between the saddle legs and frame of the baler. Do not fully tighten down bolts until unit is mounted on the baler.
2. Connect the pump plate mounting bracket (001-4646C) to the side of the saddle that has the wider profile to the legs. Using two 3/8" x 1-1/4" bolts, lock & flat washers.
3. Attach the pump plate holder (001-4646D) to the pump plate mounting bracket (001-4646C) using four 3/8" x 3/4" flange head bolts.

### 3 X 4 balers only

Locate parts bag 4. Install both saddle legs (001-6707BL & 001-6707BR) onto the saddle (001-6707A) with six 3/8" x 1-1/4" Bolts, locks and flat washers. The mounting slots in the legs will attach to the first and second weld nuts in from each end, of the saddle, on both sides. Note: There is a "V" shape cut out in the sump area of the saddle. This side of the saddle should be attached to the side of the legs that have a narrower profile.

1. Once legs and saddle are loosely attached measure the distance from the top outside corners of the bale chamber where the saddle will be attached. Move legs in or out so the inside edges will match this dimension. Also try to center the saddle within these dimensions. The spacers (001-6707BS) will be needed between the saddle legs and frame of the baler. Do not fully tighten down bolts until unit is mounted on the baler.
2. Connect the pump plate mounting bracket (001-4646C) to the side of the saddle that has the wider profile to the legs. Using two 3/8" x 1-1/4" bolts, lock & flat washers.
3. Attach the pump plate holder (001-4646D) to the pump plate mounting bracket (001-4646C) using four 3/8" x 3/4" flange head bolts

The Pump Controller and pump heads must be pointing down. Failure to mount the pump plate assembly in this specified direction will void all warranty of the Pump Controller and pumps.

## Claas 3200-3400 Large Square Balers

**Tank Mounting** – Prior to the installation of the tank assembly on the baler, the factory hand rail support that connects the hand rail to the rear tension beam must be removed. The hardware used to mount the support to the railing is reused when securing the handrail.

Fasten the legs (001-6706C) to the saddle (001-6706A) using 3/8" x 1-1/4" hex bolts (x8), 3/8" lock washers, and 3/8" flat washers. The inside distance of the legs should be approximately 48" (1.2M) Note that the tank fitting on the side of the tank should be towards that right side of the baler, opposite the ladder. Install the supplied rail support (001-6706CC) to the front side of the tank saddle using 3/8"x1-1/4" hex bolts (x2), 3/8" lock washers, and 3/8" flat washers.

Lift the tank assembly into place so it straddles the rear tension beam on top of the baler, near the end of the bale chamber. The tank legs should rest on the top corners of the bale chamber. Slide the tank as far forward as possible. With the tank slid as far forward as possible, attach the hand rail to the rail support (001-6706CC) using the factory hardware. Clamp the legs to the sides of the bale chamber and drill two 9/16" (14mm) diameter holes per leg on each side of the bale chamber. Secure the legs to the chamber with (x4) 1/2" x 1-1/2" allen head bolts, 1/2" flat washer, 1/2" lock washer, and 1/2" hex nut. At this time, the hardware securing the legs to the saddle can be loosened and adjusted. Mount the pump plate to the rear of the tank assembly.

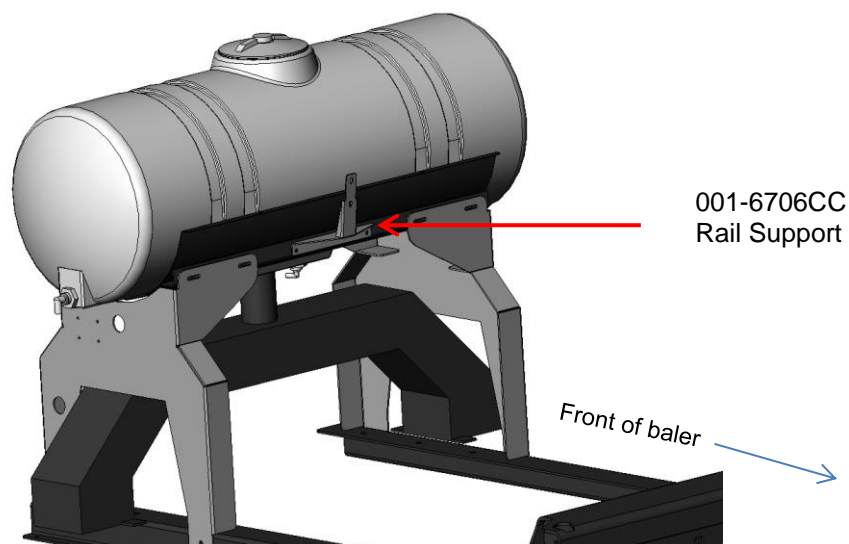
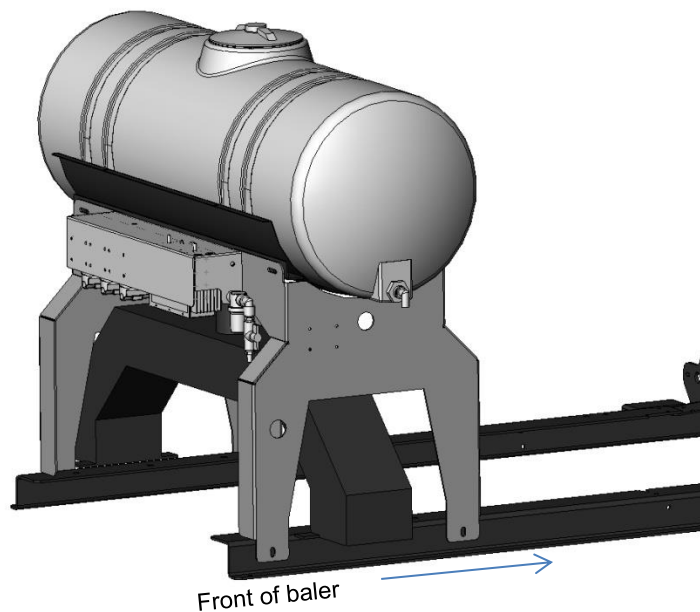



## Installation of Dual Channel Processor (DCP)

Follow the instructions below to mount the Dual Channel Processor (DCP) onto your specific baler model and type. The locations shown are the right twine box (looking at the back of the baler). Mark and drill the four 3/8" holes and install DCP with two 5/16" x 1" bolts, two 5/16" x 1-1/4" bolts, locks, fender washers and hex nuts. If your baler is not listed below mount the DCP on the back of the twine box on the right side. Mount the DCP cover over the top of the tip and secure with the hardware using the 5/16" x 1-1/4" bolts on the top with the DCP shield.

John Deere L330 / L340 Baler DCP location on the back of the right twine box will vary slightly depending on placement of safety decals from factory. Do not cover safety decals. Mount DCP on the back of right hand twine box using Figure 2 as a reference. DCP location is recommended 5" (12.5cm) from inside edge and 5" (12.5cm) from top of twine box.

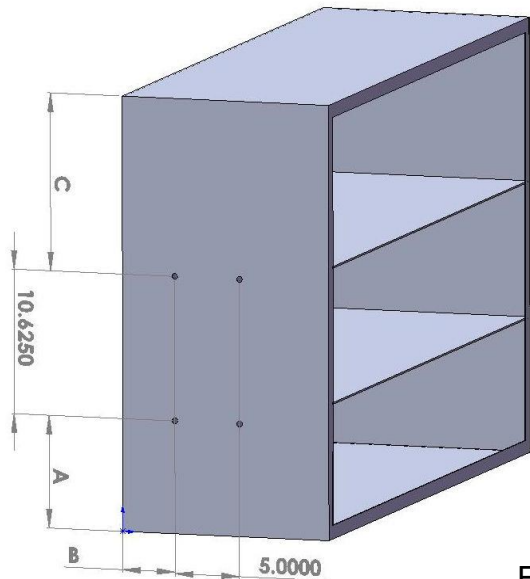

Figure 1



Figure 2

Baler Type	Model	Fig.	A	B	C	Baler Type	Model	Fig.	A	B	C
Case IH	LBX 331-431	1	4" (10cm)	2" (51mm)	N/A	Hesston	4750 – 4755	1	16" (40cm)	2" (51mm)	N/A
Case IH	LBX 332-432 & LB 333-433	1	N/A"	2" (51mm)	2" (51mm)	Hesston	4760	1	2" (51mm)	2" (51mm)	N/A
Challenger	LB 33	1	2" (51mm)	2" (51mm)	N/A	Hesston	4790	1	4" (10cm)	2.5" (64mm)	N/A
Challenger	LB34	1	4" (10cm)	2.5" (64mm)	N/A	Hesston	4800 – 4910	1	16" (40cm)	2" (51mm)	N/A
Challenger	LB44	1	16" (40cm)	2" (51mm)	N/A	John Deere	100	1	18" (45cm)	6.5" (16cm)	N/A
Claas	2100	1	4" (10cm)	2" (51mm)	N/A	Krone	890 – 12130	1	3" (70mm)	4" (10cm)	N/A
Claas	3300	1	4" (10cm)	2" (51mm)	N/A	Massey Ferguson	2050	1	2" (51mm)	2" (51mm)	N/A
						New Holland	590 – BB940	1	4" (10cm)	2" (51mm)	N/A
Kuhn, Vicon Taarup	all	1	4" (10cm)	4" (10cm)	N/A	New Holland	BB940A – 960A & BB9060 – BB9080	1	N/A	2" (51mm)	2" (51mm)



## **Installation of Tank and Star Wheel Moisture Sensors**

Use the drawing located in the back of this manual as a guide for cutting a notch and locating the mounting holes for the star wheels. Carefully mark the location of the star wheel holes using the template and a center punch so the star wheels will run true to the direction of the bales, otherwise, the star wheels may work themselves out of the block, damaging the sensor itself or the bale rate sensors. The star wheels must be mounted so that they are no closer than 3/8" (10mm) from any metal parts of the baler and come in contact only with the bale. 5/16" Allen headed bolts will be used to mount the star wheel block and twine guard to the baler. The bolts must be inserted from the inside of the baler chamber. Use nuts and lock washers to hold the bolts in place before putting on the star wheel block, the block is counter-bored on one side so the block will fit over the nuts. The star wheel block has a plug on one side and a wire grommet on the other side. If there are interference problems with the star wheel wires on one side of the block, exchange the wire grommet with the plug so the wire can exit the block on the other side. Mount the twine guards using the two inner holes on the star wheel block. The twine guard containing the bale rate sensors should be placed on the baler's right side, when looking from the back of the baler.

\*Claas Quadrant 3200 – 3400 balers will mount star wheels on side of bale chamber.  
Refer to page 19 for instructions.

**The following pages will contain detailed instructions for your baler. Please refer to the table of contents for you exact listing.**

## New Holland 590 through BB9080 and Case IH LBX331 through LB433 Balers

**Tank Mounting-**Locate parts bag A & 2. Mount the tank legs and saddle on the baler as shown below. The tank legs bolt to the baler with six 1/2" x 1-3/4" carriage bolts, lock & flat washers, and hex nuts. Depending on the baler model, 9/16" (14mm) holes (3 per side) may need to be drilled in the baler to bolt down the tank legs. The bolts should be inserted from inside the baler.

The saddle is intentionally tipped forward by 5° so that the tank cap will be parallel to the ground. There is a small cut out "V" where the tank sump fits in the saddle and this cut out should face the back of the baler for the tank to be level when installed on the baler.

**Star Wheel Mounting-**Use the template located in the back of the manual as a guide for cutting the notch and mounting holes for the star wheels. The star wheels are to be mounted on top of the baler, just behind the knotters and under the walkway on both sides. Remove the bale from the chute, tip the walkway up and locate the wheels on the top outside corner angles of the bale chute, one on each side. Some balers may already have the notch cut and square holes. If so, the holes will need to be drilled round with a 5/16" drill bit. A 1/2" x 1/2" cut may also need to be made at the base of the twine arm mounting bracket for the star wheel to sit correctly on the bale chamber. Mark the location of the notch 5/8" wide and 9" long (16mm x 23cm) and the location of the four 5/16" (8mm) holes for the star wheel base. After cutting the notch and drilling the hole, insert the 5/16" x 3" x black allen head bolts up through the chute and use nuts to hold the bolts in place. Place the star wheel block over the nuts and install the twine guards using the two inner holes of the star wheel block. The twine guard containing the bale rate sensors will be placed on the right side. See Step 8 for directions on how to hook-up the star wheel wires.

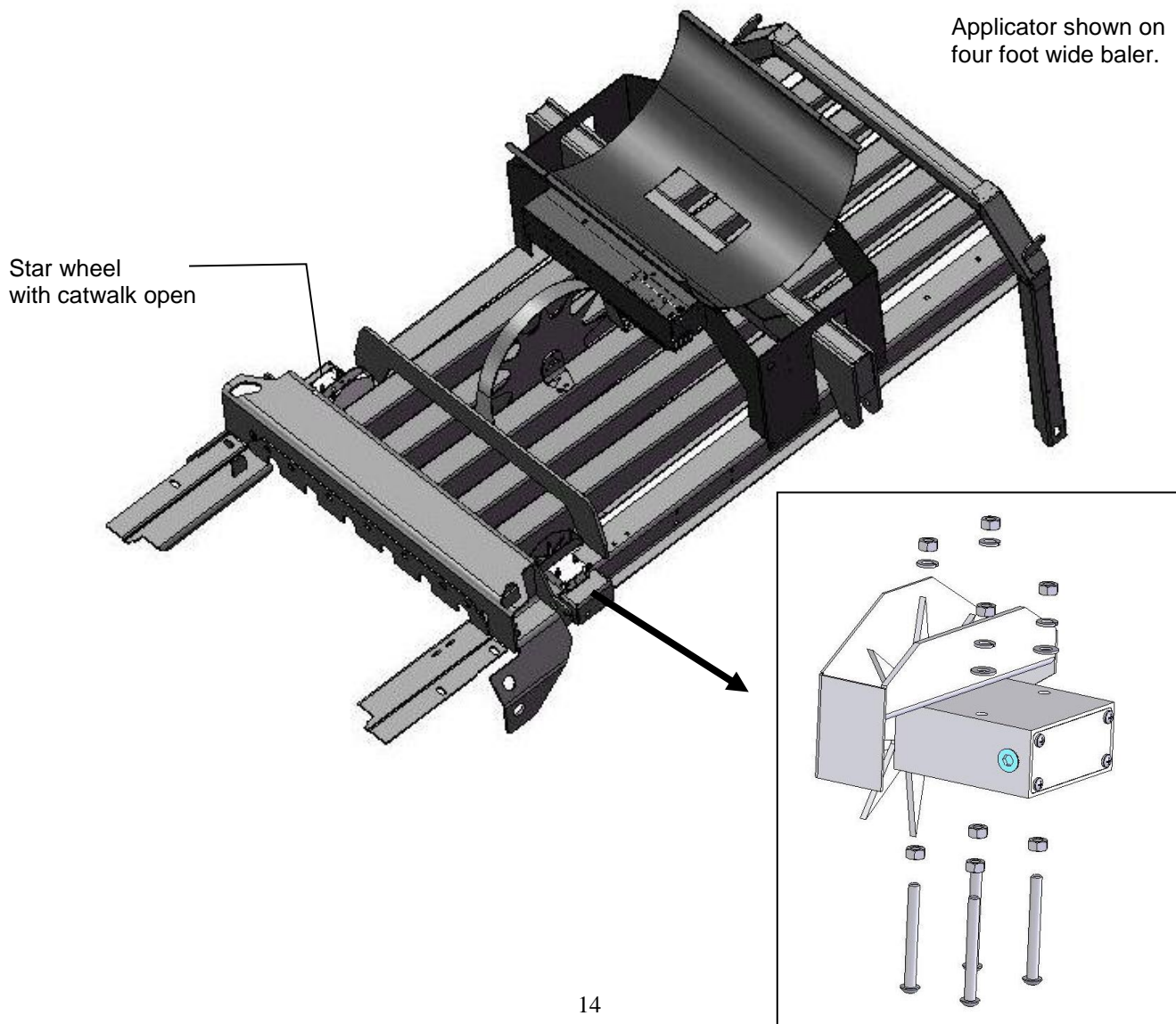

**Case IH 8570, 8575, and 8585, Challenger LB33, LB34, and Hesston 7430, 4750, 4755, 4760, and 4790, and Massey Ferguson 2050, and New Idea 7233, 7333, 7234 Balers**

**Tank Mounting-** Locate parts bag A & 2. Mount the tank legs and saddle on the baler as shown below, centered between the compression arm and the crossbeam. The tank legs bolt to the baler with six 1/2" x 1-3/4" carriage bolts, locks & flat washers and hex nuts. Depending on the baler model, 9/16" holes (3 per side) may need to be drilled in the baler to bolt down the tank legs. The bolts should be inserted from inside the baler.

The saddle is intentionally tipped forward by 5° so that the tank cap will be parallel to the ground. There is a small cut out "V" where the tank sump fits in the saddle and this cut out should face the back of the baler for the tank to be level when installed on the baler.

**Star Wheel Mounting –** The star wheels are mounted under the walkway on top of the baler behind the knotters. Remove the bale from the chute and tip the walkway up. Locate the star wheel template on the outside corner angles of the bale chute on the left and right side of the baler. The center of the wheel shaft will be approximately 5-1/2" (13cm) in front of the walkway support or about halfway between the walkway support and the cross frame almost directly in front of it. The notch will start just in front of the walkway support.

Two parts of the baler frame will have to be trimmed off on both sides to mount each star wheel. The first is the outside corner angles of the chute. Use the template to mark the location of the star wheel notch as well as the location of the four holes for the star wheel base. The notch will be 5/8" by 9" (16mm x 23cm) long and will help keep the wheel away from the twine. Spray the ground off areas with touch up paint to prevent rusting. The second portion of the baler to trim off is the end of the gusset that may interfere with the star wheel's plastic base support. Center the star wheel in the slots that was just notched and check for interference with the gusset.

Drill 5/16" (8mm) holes for the star wheel block. Insert the 5/16" x 3" bolts up through the chute and use nuts to hold the bolts in place. Place the star wheel block over the nuts and install the twine guards using the two inner holes of the star wheel block. **The twine guard containing the bale rate sensors will be placed on the right side of the baler.** See Step 8 for directions on how to hook-up the star wheel wires.

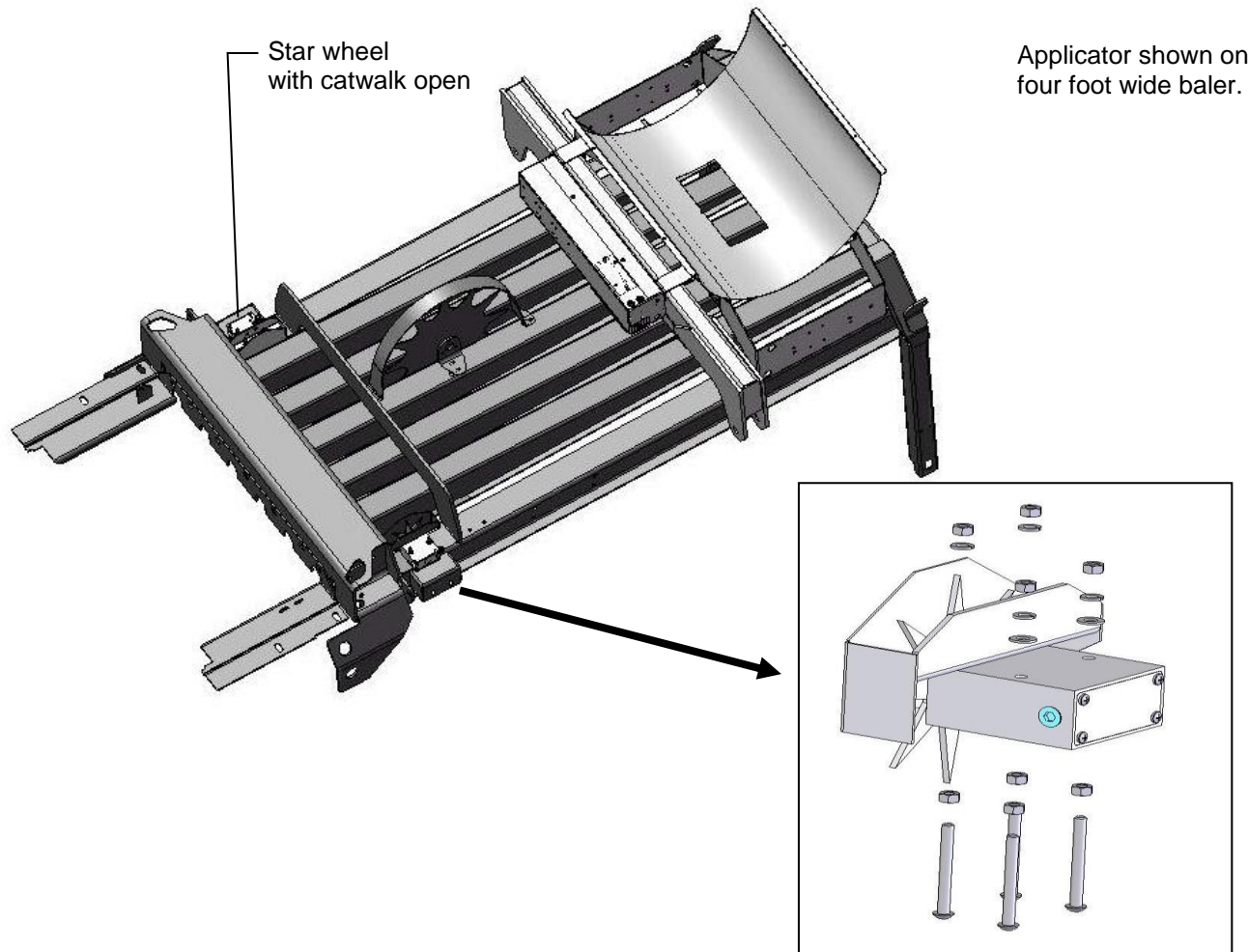

## Case IH 8580 and 8590, Hesston 4900 and 4910, Challenger LB44, and New Idea 7244 Balers

**Tank Mounting** – Locate parts bag A & 2. Mount the tank legs and saddle on the baler as shown below, centered between the compression arm and the crossbeam. The tank legs bolt to the baler with 1-3/4" carriage bolts, flat and lock washers, and hex nuts. Depending on the baler model, 9/16" (14mm) holes (3 per side) may need to be drilled in the baler to bolt down the tank legs. The bolts should be inserted from inside the baler. Bolt the ladder bracket extensions (001-6707H) on the side of the tank legs and attach the balers existing ladder.

The saddle is intentionally tipped forward by 5° so that the tank cap will be parallel to the ground. There is a small cut out "V" where the tank sump fits in the saddle and this cut out should face the back of the baler for the tank to be level when installed on the baler.

**Star Wheel Mounting** –The star wheels are mounted on top of the baler, just behind the knotters under the walkway on both sides. Use the template at the back of the manual to mark the location and dimension of the notch and holes. Remove the bale from the chute. Tip the walkway up and locate the wheels on the top outside corner angles of the bale chute, one on each side. The star wheel block is located just in front of the horizontal channels holding the twine boxes. Using the template, mark the location of the notch (5/8" wide and 9" long) and the location of the four 5/16" (8mm) holes for the star wheelbase using a center punch. Any bare metal edge of the angle should be sprayed with touch up paint to prevent corrosion.

Once the above modification to the baler is made on both sides of the chute, the wheels can be mounted. Insert the 5/16" x 3" bolts up through the chute and use nuts to hold the bolts in place. Place the star wheel block over the nuts and install the twine guards using the two inner holes of the star wheel block. **The twine guard containing the bale rate sensors will be placed on the right side of the baler.** See Step 8 for directions on how to hook-up the star wheel wires.

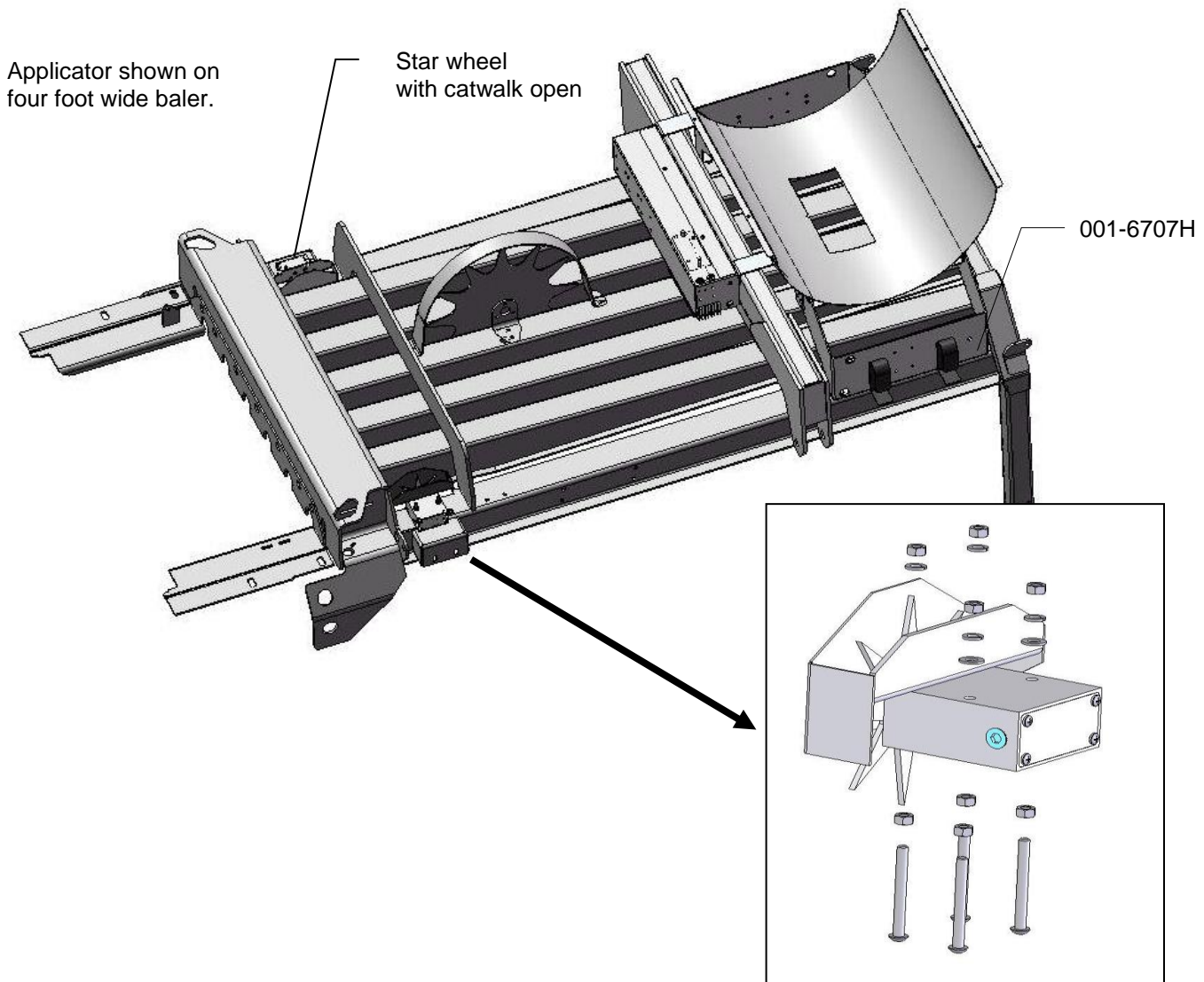



## Vermeer SQ2731 and SQ3347 Balers

**Tank Mounting** – Locate parts bag A & 3. Mount the tank legs and saddle on the baler as shown below. The tank legs bolt to the baler with six 1/2" x 1-3/4" Allen head bolts, lock & flat washers, and hex nuts. You will need to drill 9/16" (14mm) holes (3 per side) in the baler to bolt down the tank legs. The bolts should be inserted from inside the baler.

The saddle is intentionally tipped forward by 5° so that the tank cap will be parallel to the ground. There is a small cut out "V" where the tank sump fits in the saddle and this cut out should face the back of the baler for the tank to be level when installed on the baler.

**Star Wheel Mounting** – Locate the steel crossbeam that goes across the bale chamber in between the knotters and shield for the hydraulic cylinder. The yellow shield is located in the middle and runs in the same direction as the bale chamber. Using the provided star wheel template, locate the template as far forward as possible behind the crossbeam. Position the template so the edge of the star wheel base is aligned with the outside of the bale chamber. Mark the hole positions for drilling and also mark the notch for the star wheels. The notch will be 5/8" x 9" long and will help keep the wheel away from the twine. Repeat this process on the other side of the bale chamber for the second star wheel. Insert the 5/16" x 3" bolts up through the chute and use nuts to hold the bolts in place. Place the star wheel block over the nuts and install the twine guards using the two inner holes of the star wheel block. **The twine guard containing the bale rate sensors will be placed on the right side of the baler.** See Step 8 for directions on how to hook-up the star wheel wires.

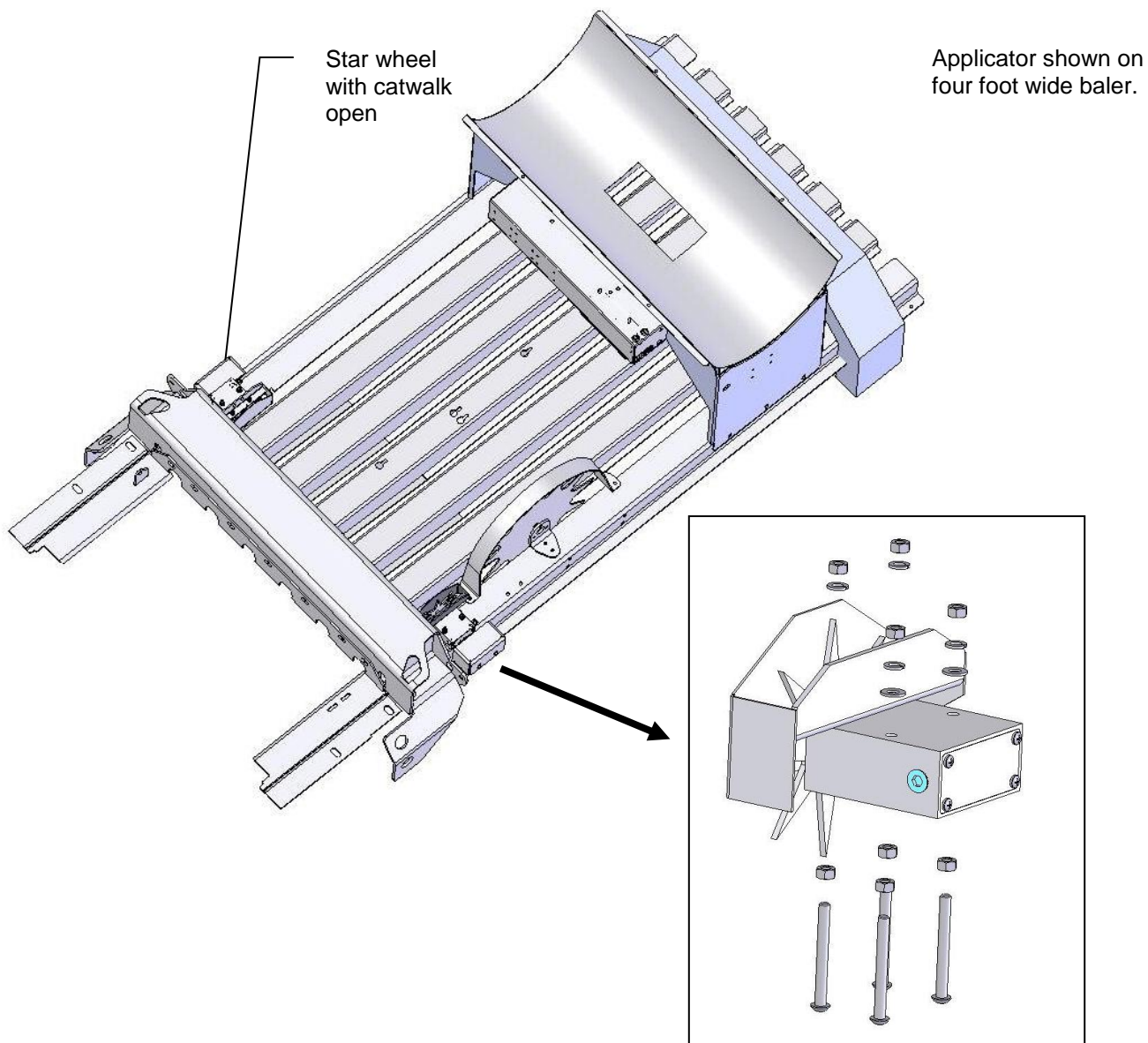

## Claas 2100 and 2200 Balers

**Tank Mounting** – Locate parts bag A & 3. Mount the tank legs and saddle on the baler as shown below. The tank legs bolt to the baler with six 1/2" x 1-3/4" Allen head cap screws, flat & lock washers, and hex nuts. You will need to drill 9/16" holes (3 per side) in the baler to bolt down the tank legs. The bolts should be inserted from inside the baler. Make sure to mount the tank legs as far back as possible to allow room for using the ladder.

The saddle is intentionally tipped forward by 5° so that the tank cap will be parallel to the ground. There is a small cut out "V" where the tank sump fits in the saddle and this cut out should face the back of the baler for the tank to be level when installed on the baler.

**Star Wheel Mounting** – Use the template located in the back of the manual as a guide for cutting the notch and mounting holes for the star wheels. The star wheels are to be mounted on top of the baler, just behind the knotters and as far forward as possible. Remove the bale from the chute. Locate the wheels on the top outside corner angles of the bale chute, one on each side. Mark the location of the notch 5/8" wide and 9" long (16mm x 23cm) and the location of the four 5/16" (8mm) holes for the star wheel base. After cutting the notch and drilling the hole, insert the 5/16" x 3" black Allen head bolts up through the chute and use nuts to hold the bolts in place. Place the star wheel block over the nuts and install the twine guards using the two inner holes of the star wheel block. **The twine guard containing the bale rate sensors will be placed on the right side.** See Step 8 for directions on how to hook-up the star wheel wires.

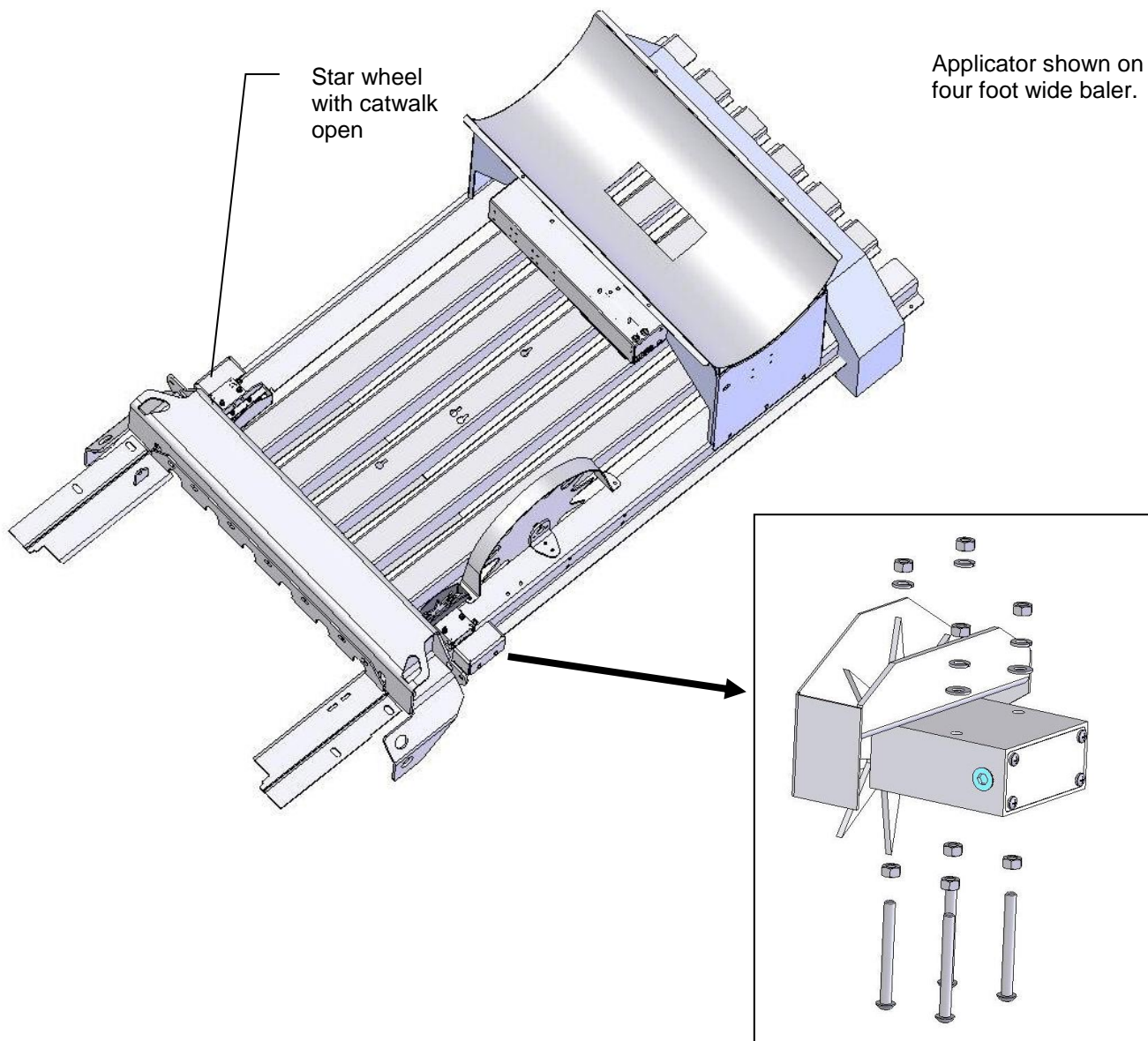

## Claas 3200-3400 Large Square Balers continued

**Star Wheel Mounting** – Use the picture below as a guide for drilling the mounting holes for the star wheels. The star wheels are to be mounted on the side of the bale chamber, between the top and middle channel. Measure 10" back from the hinge between the top and middle channel. Cut 1" x 9" (25mm x 23cm) slot for the star wheel. Make sure the wheel is square. Mark the location of the two 5/16" holes for the star wheel base. After drilling the holes, insert the 5/16" x 3 1/4" allen head bolts through the chute and use nuts to hold the bolts in place. Place the star wheel block over the nuts and install the prox sensor holder (001-4644H) on the star wheel located on the right side of the baler. Note: Thicker side of block goes to baler side.





## Krone Large Square

**Tank Mounting** – Locate parts bag A & 3. Mount the tank legs and saddle on the baler as shown below. The tank legs bolt to the baler with six 1/2" x 1-3/4" Allen head cap screws, flat & lock washers, and hex nuts. You will need to drill 9/16" holes (3 per side) in the baler to bolt down the tank legs. The bolts should be inserted from inside the baler.

The saddle is intentionally tipped forward by 5° so that the tank cap will be parallel to the ground. There is a small cut out "V" where the tank sump fits in the saddle and this cut out should face the back of the baler for the tank to be level when installed on the baler.

**Star Wheel Mounting-For non-HDP models** remove the bale for the bale chute. The star wheels are to be mounted on top of the baler, just behind the knotters and as far forward as possible. Use the table and diagram below to mark the four bolt hole locations on the bale chamber (C,D,E,F). Use the template in the back of the manual to mark the location of the notch to be cut. When cutting the notch both the vertical brace and the bale chamber will need to be cut. Before cutting verify the notch measurement with the below diagram using marks A & B. After cutting the notch and drilling the holes, insert the 5/16" x 3" black Allen head bolts up through the chute and use nuts to hold the bolts in place. Place the star wheel block over the nuts and install the twine guards using the two inner holes of the star wheel block. **The twine guard containing the bale rate sensors will be placed on the right side.** See Step 8 for directions on how to hook-up the star wheel wires.

**For 2010 Krone HDP part number 20 073 194 0 must be ordered. This kit will include mounting instructions for the star wheels.**

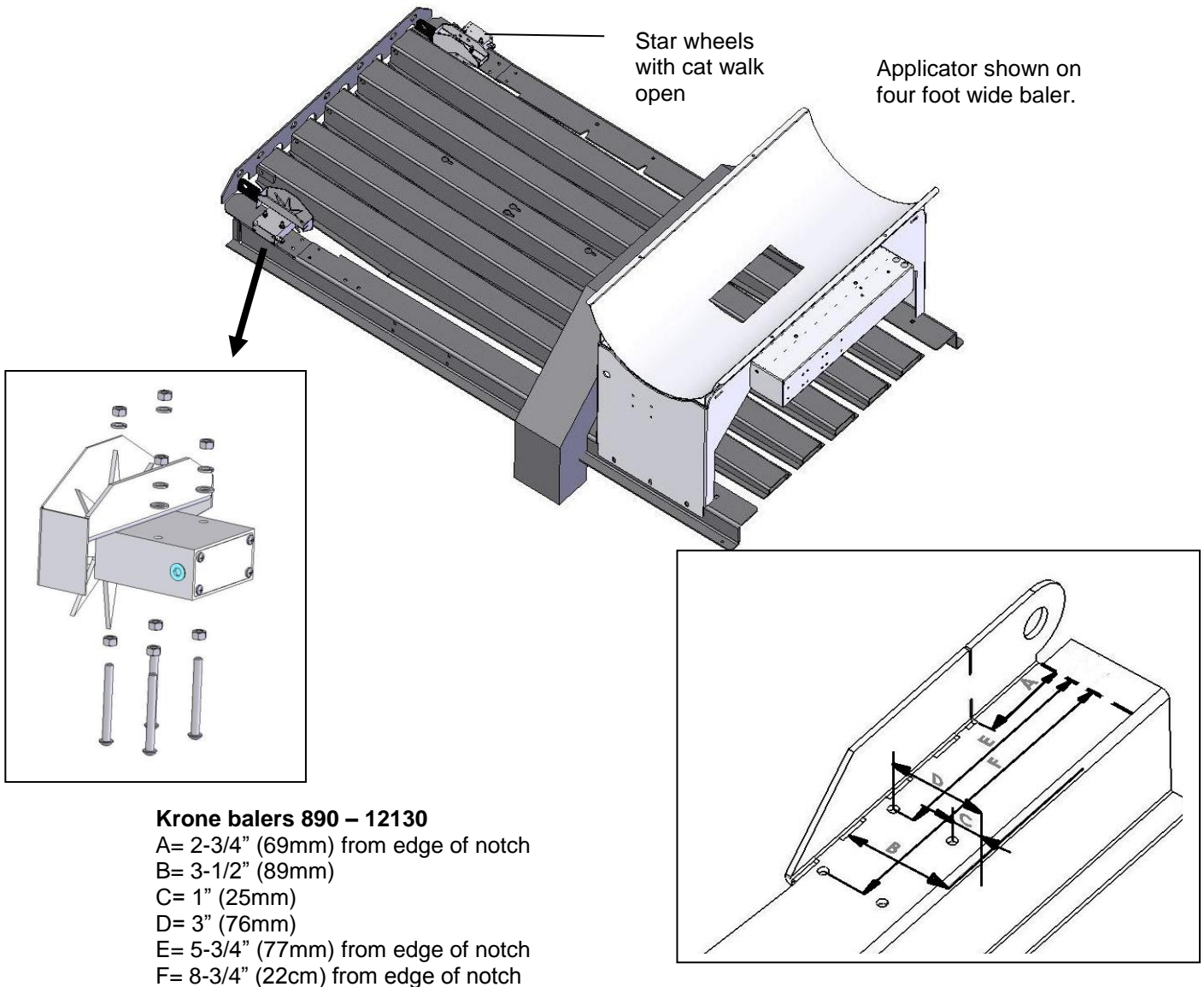



## Kuhn LSB 870 – 1290, Vicon LB 8200 and LB 12200 & Taarup 6570 – 6690 OC

**Tank Mounting** – Locate parts bag B & 4. Mount the tank legs and saddle on the baler as shown below. Insert the two 001-6707BS spacers between the legs and saddle legs. The tank legs bolt to the baler with six 1/2" x 3-1/2" Allen head cap screws, lock & flat washers, and hex nuts. The bolts should be inserted from inside the baler.

The saddle is intentionally tipped forward by 5° so that the tank cap will be parallel to the ground. There is a small cut out "V" where the tank sump fits in the saddle and this cut out should face the back of the baler for the tank to be level when installed on the baler.

**Star Wheel Mounting**-Use the template in the back of the manual labeled Vicon large square balers for this installation. The star wheels are to be mounted on top of the baler, just behind the knotters and under the walkway on both sides. Remove the bale from the chute, mount the star wheels flush with the back of the walkway with one star wheel on each side. Mark the holes inside the chamber, and drill the two holes per side, for mounting from inside the chamber. Insert the 5/16" x 3" black Allen head bolts up through the chute and use nuts to hold the bolts in place. Place the star wheel block over the nuts and install the twine guards using the two inner holes of the star wheel block **The twine guard containing the bale rate sensors will be placed on the right side.** See Step 8 for directions on how to hook-up the star wheel wires.

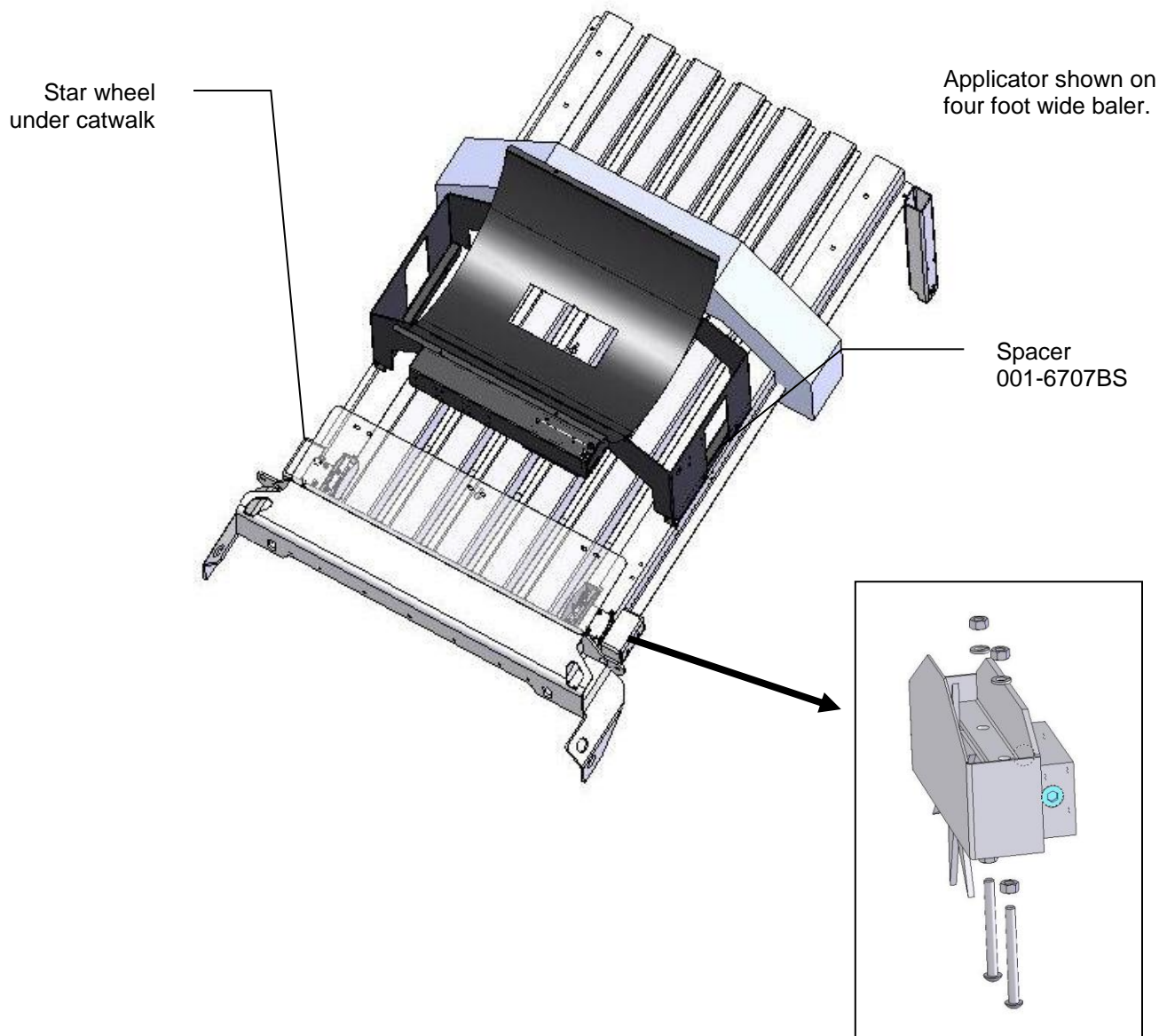

## Installation of End of Bale Sensor

The end of bale sensor determines the position of the needles on the baler. When the needles cycle the sensor communicates this information to the Dual Channel Processor (DCP). This information is used for job records and will be used by the optional Bale Identification System. Follow the steps below for your baler to mount the sensor.

**All AGCO Hesston 4760 – 4790 and equivalents, Case IH LBX 331 – LB 433, Class 2100, John Deere 100, New Holland 590 – BB 9080**

End of bale sensor bracket (001-4648) will be used. Cutoff excess metal not used during installation.

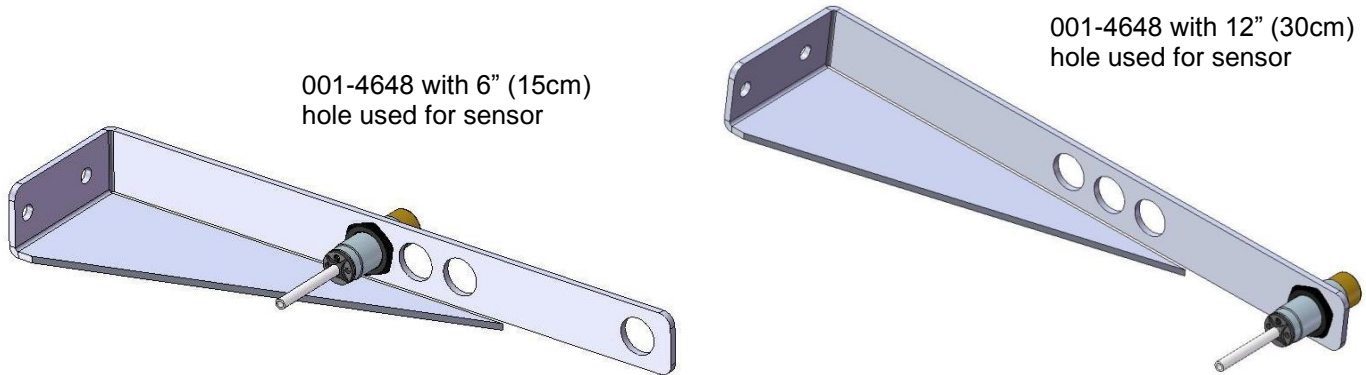

**All Hesston 4750 – 4755 & 4900 – 4910**

End of bale sensor bracket (001-4648) and Hesston end of bale mount (001-4648H) will be used. The Hesston end of bale mount will be found in the installation kit box. Cutoff excess metal not used during installation.

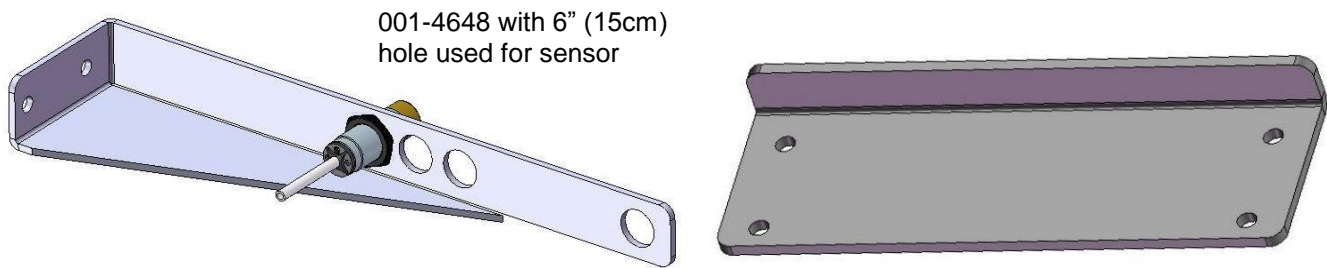

## All Krone 890 – 12130

Krone end of bale sensor bracket (001-4648K or 001-4648K2) be used. The Krone end of bale mount will be found in the installation kit box. The 001-4648K will be used with balers 890 – 1290. The 001-4648K2 will be used with the 12130 baler.

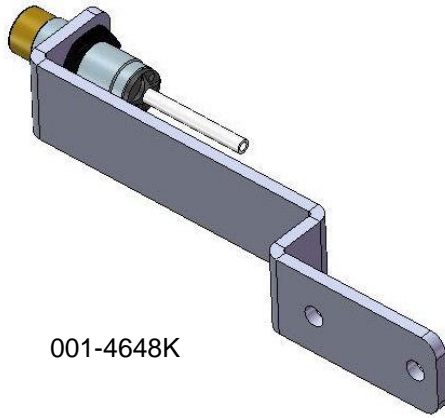

001-4648K

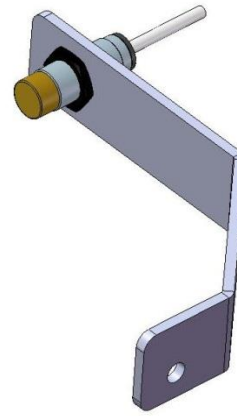

001-4648K2

## All Kuhn, Vicon and Taarup Balers

End of bale sensor bracket (001-4648) will be used. Cutoff excess metal not used during installation.

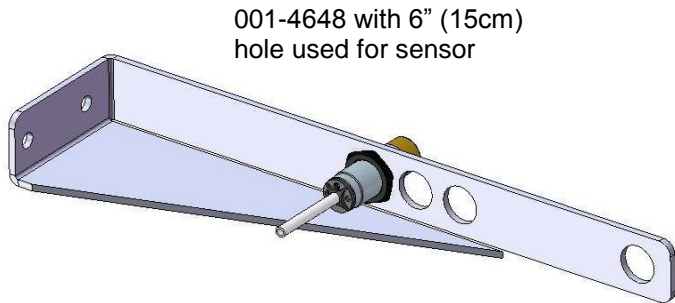

001-4648 with 6" (15cm)  
hole used for sensor

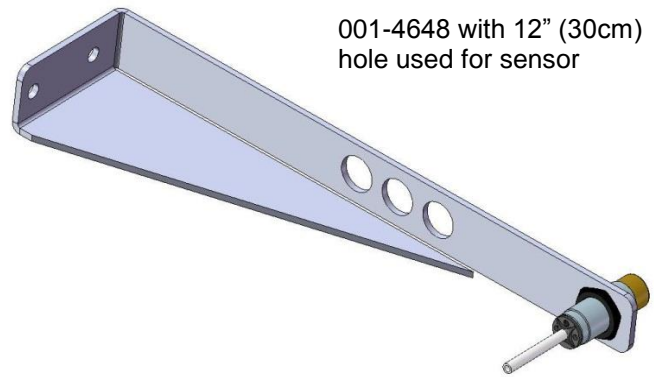

001-4648 with 12" (30cm)  
hole used for sensor

## End of Bale Sensor Installation Diagram

Hesston 4750-4755 & 4900 – 4910

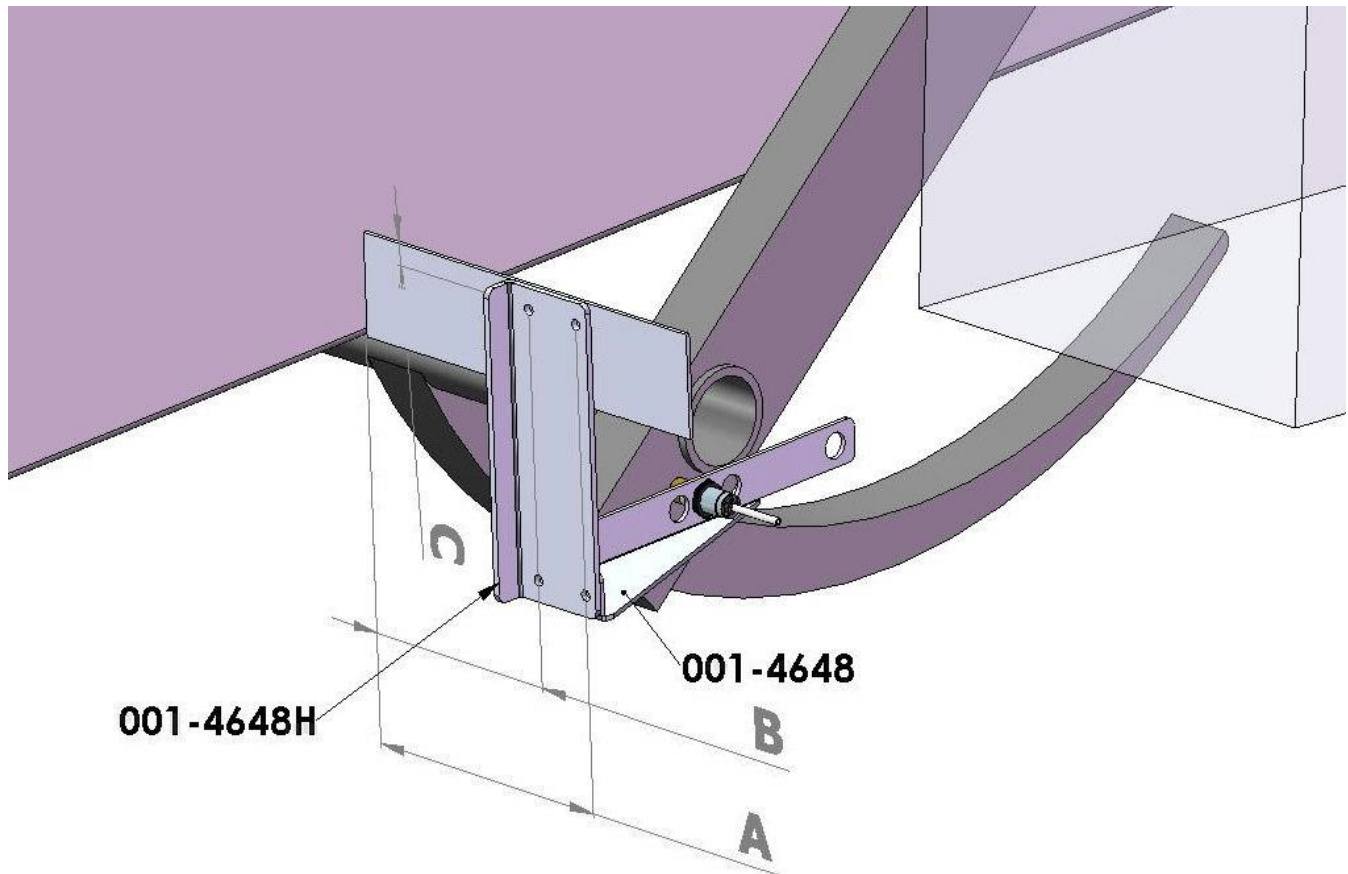

Sensor hole location	A	B	C
7" (18cm)	7-7/8" (20cm)	9-5/8" (25cm)	5/8" (16mm)

Attach the Hesston end of bale mount (001-4648H) as shown. Attach the end of bale sensor bracket (001-4648) to the Hesston end of bale mount (001-4648H) using two 1/4" x 1" bolts, locks & flat washers and hex nuts. Align the brackets and mark the two 3/8" (10mm) holes to be drilled. Attach the brackets to the baler using two 5/16" x 1 self-tapping screws, and flange nuts. Mount the sensor in the 7" (18cm) hole location, keep the sensor 1/4" (7mm) from the needle and tighten both nuts. Cut off excess metal past the sensor. Run the sensor cable up to the Precision Information Processor and secure to the baler.

**Hesston 4760 & 4790**

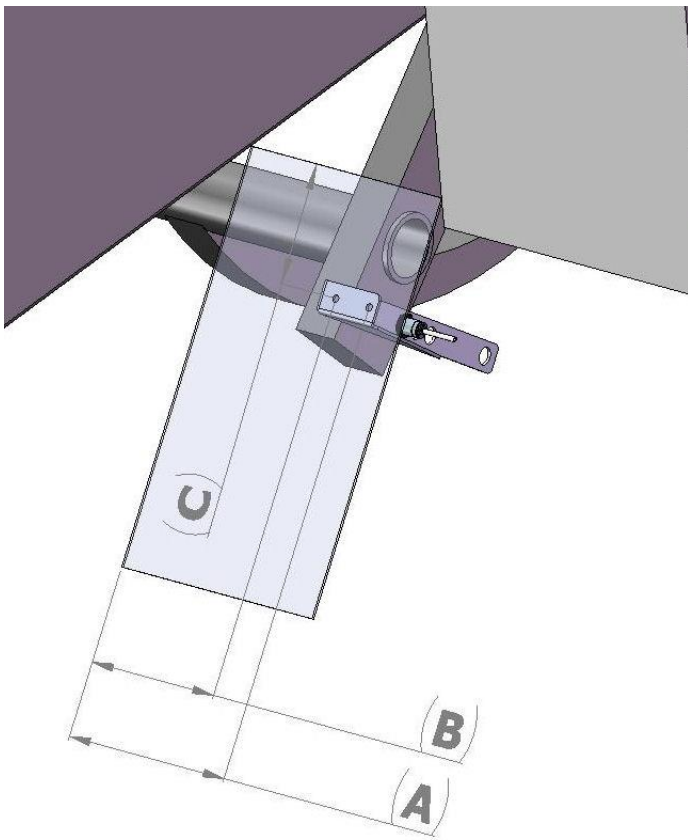

Hesston 4760

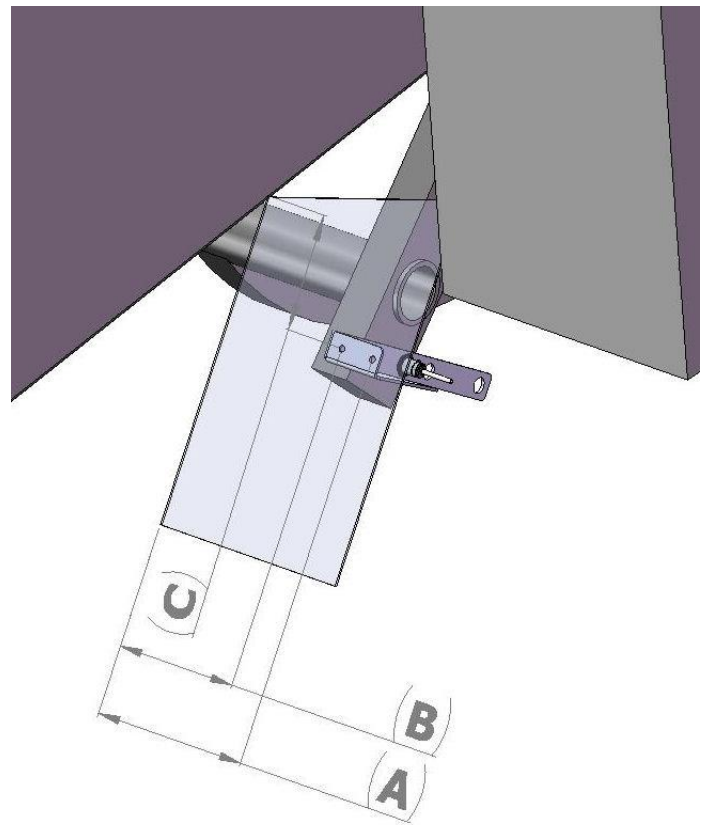

Hesston 4790

Baler	Sensor hole location	A	B	C
4760	6"	6-5/8"	4-7/8"	4"
4790	6"	4-5/8"	2-7/8"	3"

Mount the end of bale sensor bracket (001-4648) as shown. Mark and drill two 3/8" holes and attach the bracket using two 5/16" x 1" self-tapping screws, and 5/16" flange nuts. Mount the sensor in the 6" (15cm) hole location, keep the sensor 1/4" (7mm) from the needle and tighten both nuts. Cut off excess metal past the sensor. Run the sensor cable up to the Dual Channel Processor (DCP) and secure to the baler.

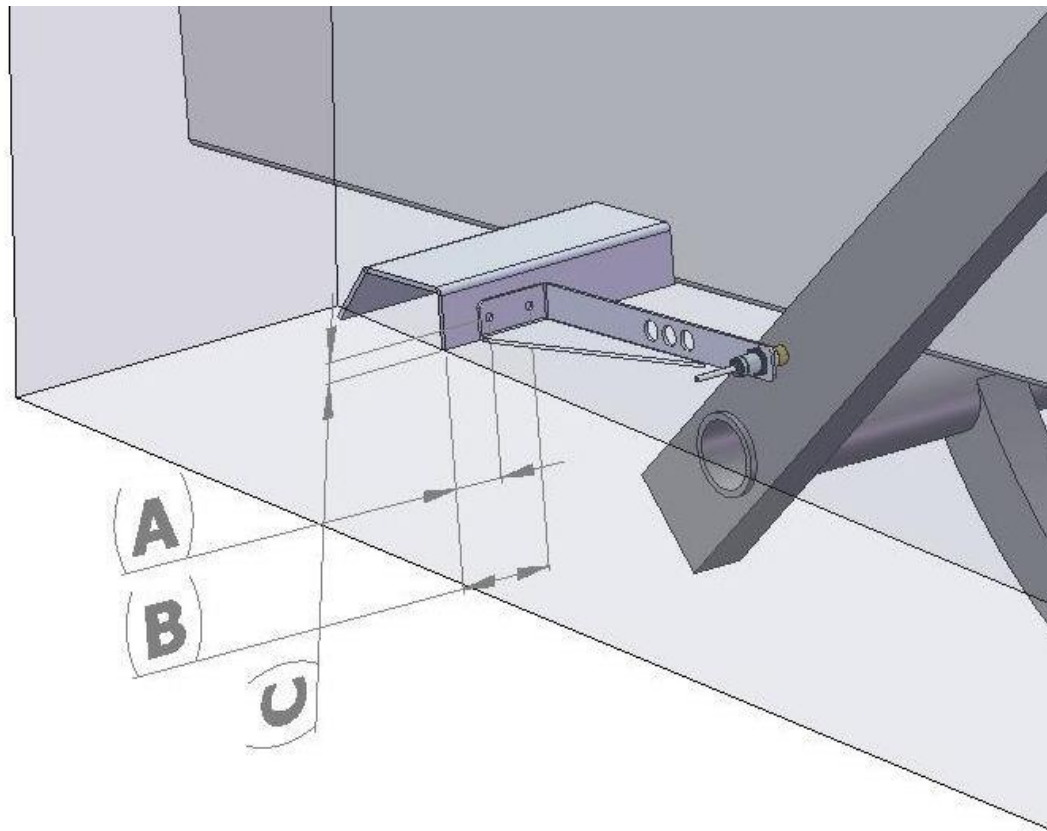

Sensor hole location	A	B	C
12" (30cm)	2-7/9" (76mm)	4-3/8" (12cm)	5/8" (16mm)

Mount the end of bale sensor bracket (001-4648) as shown. Mark and drill two 3/8" holes and attach the bracket using two 5/16" x 1" self-tapping screws, and 5/16" flange nuts. Mount the sensor in the 12" hole location, keep the sensor 1/4" (7mm) from the needle and tighten both nuts. Run the sensor cable up to the Dual Channel Processor (DCP) and secure to the baler.



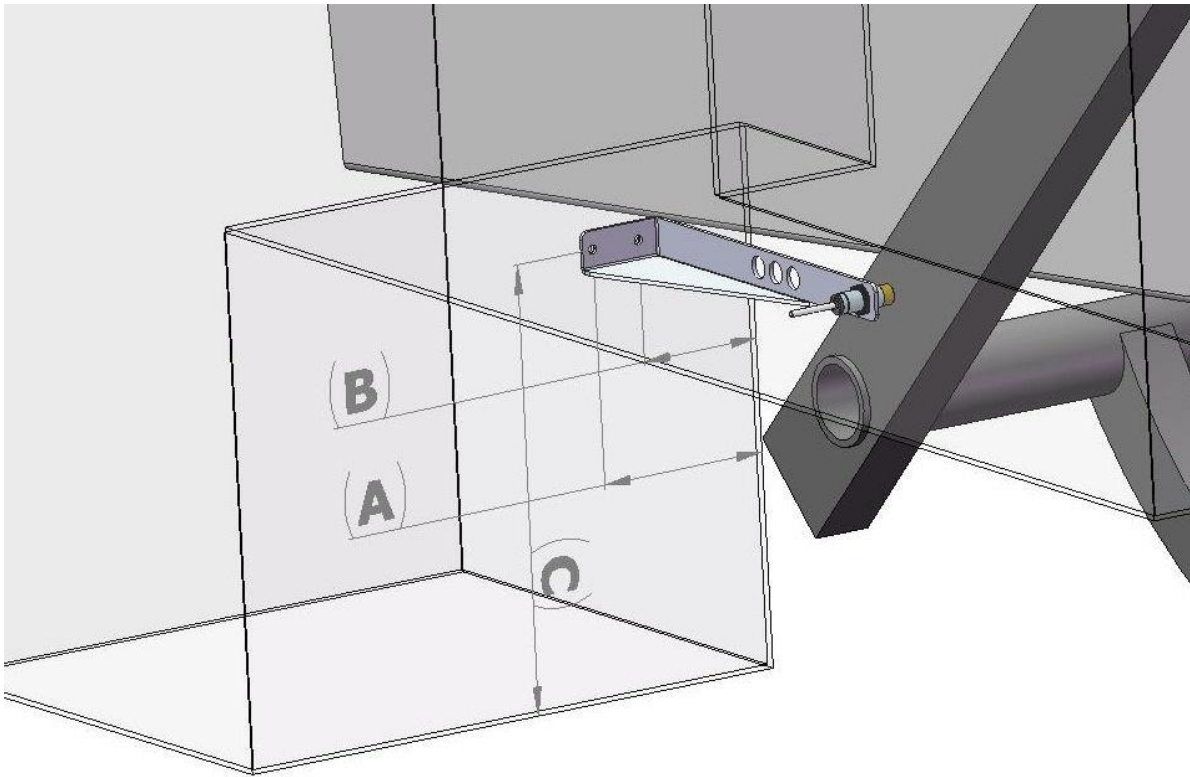

Sensor hole location	A	B	C
12" (30cm)	6-1/8" (15cm)	4-3/8" (12cm)	15" (38cm)

Mount the end of bale sensor bracket (001-4648) as shown. Mark and drill two 3/8" holes and attach the bracket using two 5/16" x 1" self-tapping screws, and 5/16" flange nuts. Mount the sensor in the 12" (30cm) hole location, keep the sensor 1/4" (7mm) from the needle and tighten both nuts. Run the sensor cable up to the Dual Channel Processor (DCP) and secure to the baler.

**Claas 2100**

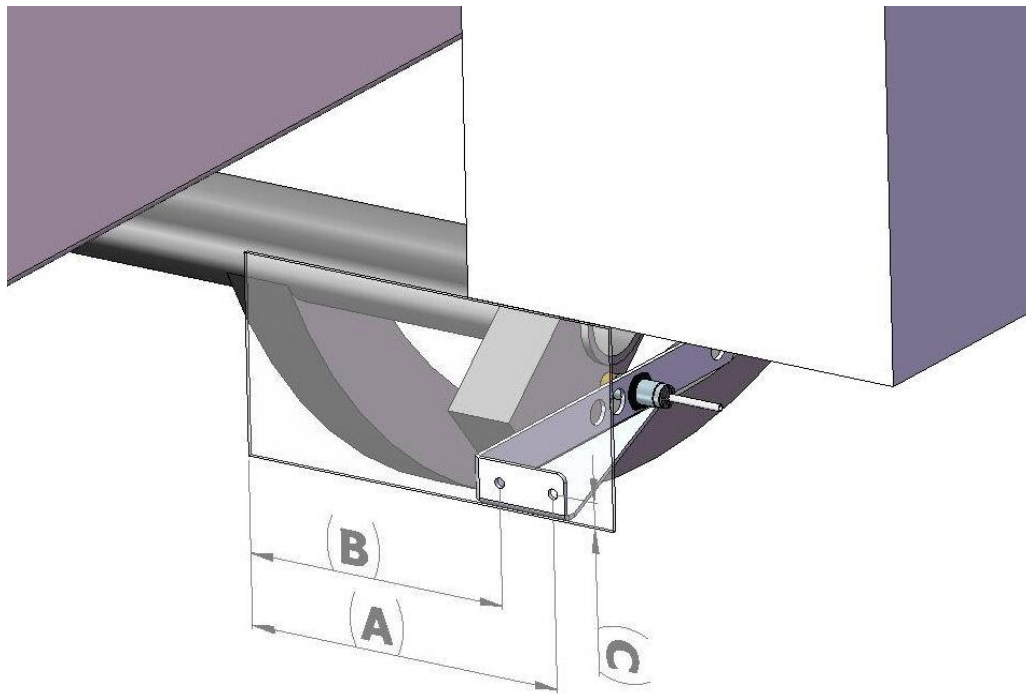

Sensor hole location	A	B	C
8" (20cm)	5-3/4" (13cm)	4" (10cm)	5/8" (16mm)

Mount the end of bale sensor bracket (001-4648) as shown. Mark and drill two 3/8" (10mm) holes and attach the bracket using two 5/16" x 1" self-tapping screws, and 5/16" flange nuts. Mount the sensor in the 8" (20cm) hole location, keep the sensor 1/4" (7mm) from the needle and tighten both nuts. Cut off excess metal past the sensor. Run the sensor cable up to the Dual Channel Processor (DCP) and secure to the baler.

**Claas 3200-3400**

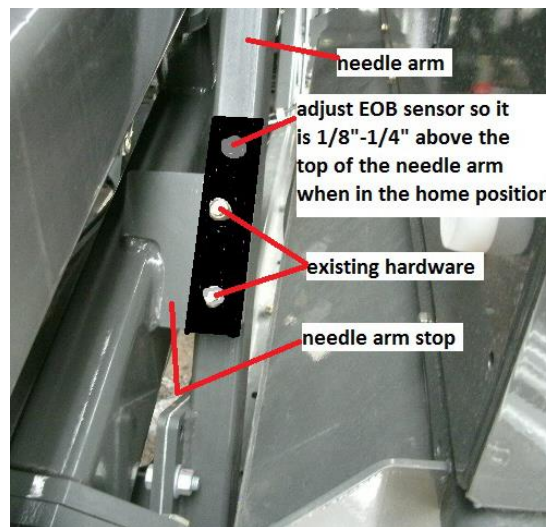
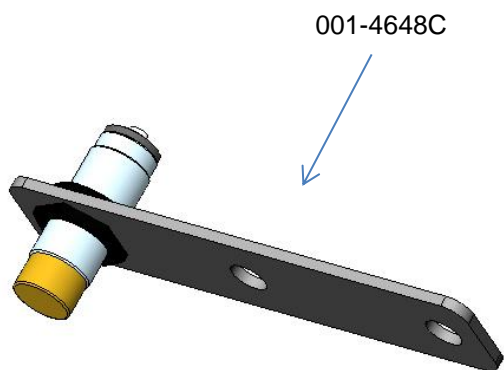

The end of bale (EOB) sensor mounts in the EOB bracket (001-4648C) as shown in the picture. The EOB bracket is mounted to the top side of the needle arm stop using the existing hardware that secures the bumper to the stop.



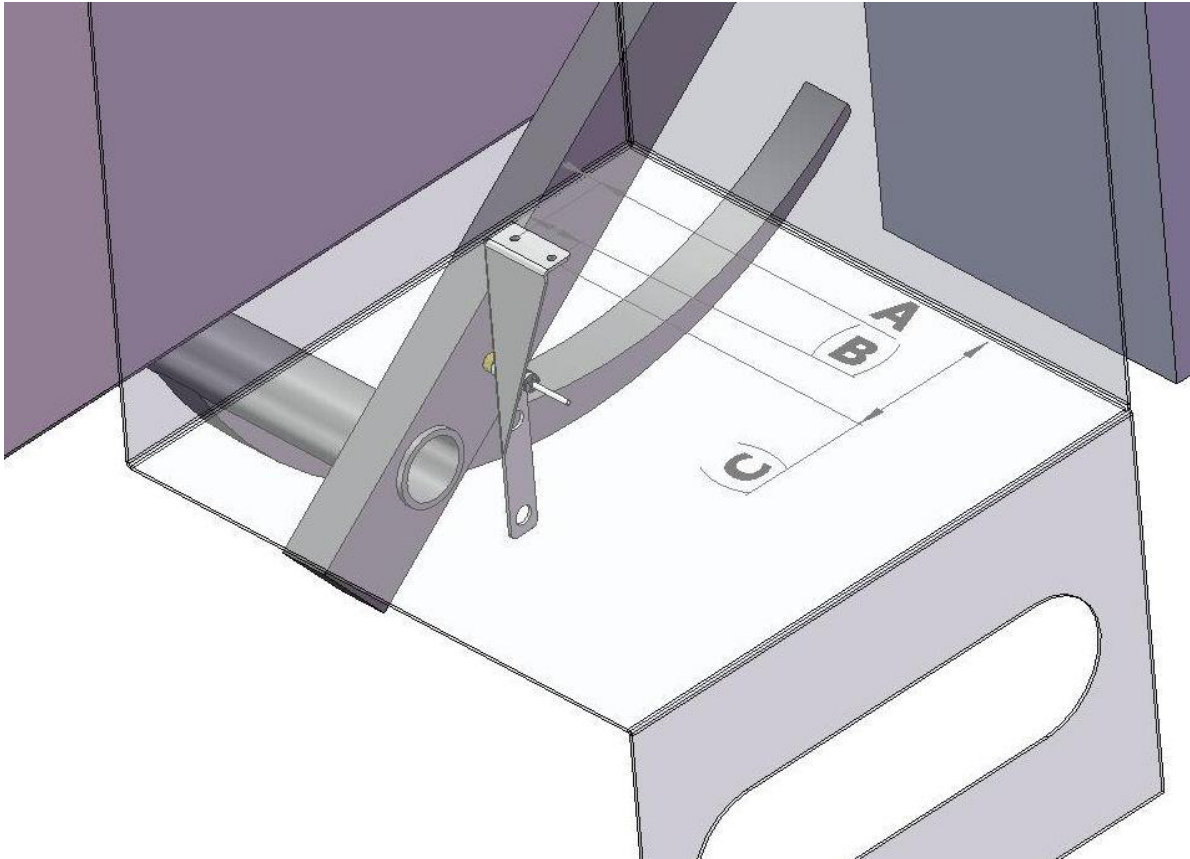

Sensor hole location	A	B	C
6" (15cm)	2-5/8" (70mm)	7/8" (22mm)	7" (18cm)

Mount the end of bale sensor bracket (001-4648) as shown. Mark and drill two 3/8" (10mm) holes and attach the bracket using two 5/16" x 1" self-tapping screws, and 5/16" flange nuts. Mount the sensor in the 6" (15cm) hole location, keep the sensor 1/4" (7mm) from the needle and tighten both nuts. Cut off excess metal past the sensor. Run the sensor cable up to the Dual Channel Processor (DCP) and secure to the baler.

## Krone 890 – 1290

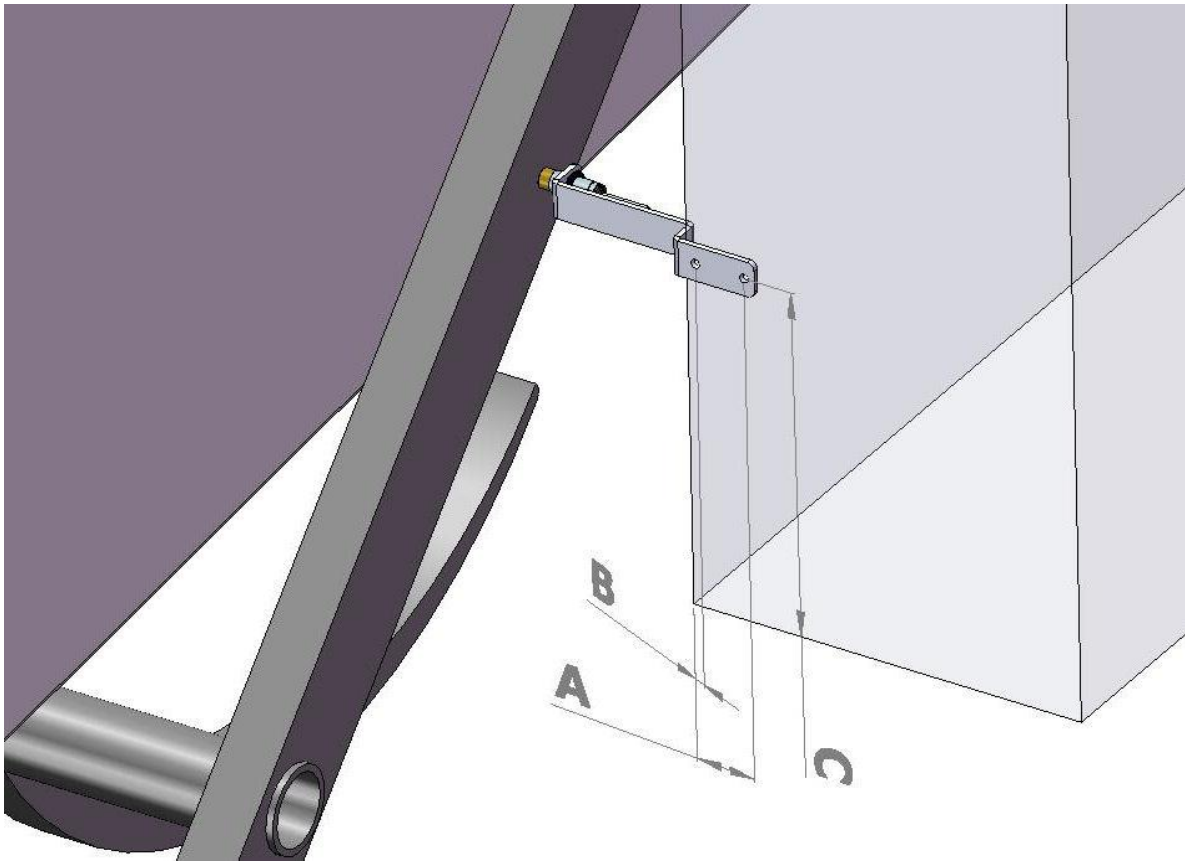

Sensor hole location	A	B	C
N/A	2-1/4" (65mm)	1/2" (13mm)	8" (20cm)

Mount the Krone end of bale sensor bracket (001-4648K) as shown. The Krone mounting bracket can be found in the installation kit box. Mark and drill two 3/8" (10mm) holes and attach the bracket using two 5/16" x 1" self-tapping screws, and 5/16" flange nuts. Mount the sensor at the end of the bracket, keep the sensor 1/4" (7mm) from the needle and tighten both nuts. Run the sensor cable up to the Dual Channel Processor (DCP) and secure to the baler.

## Krone 12130

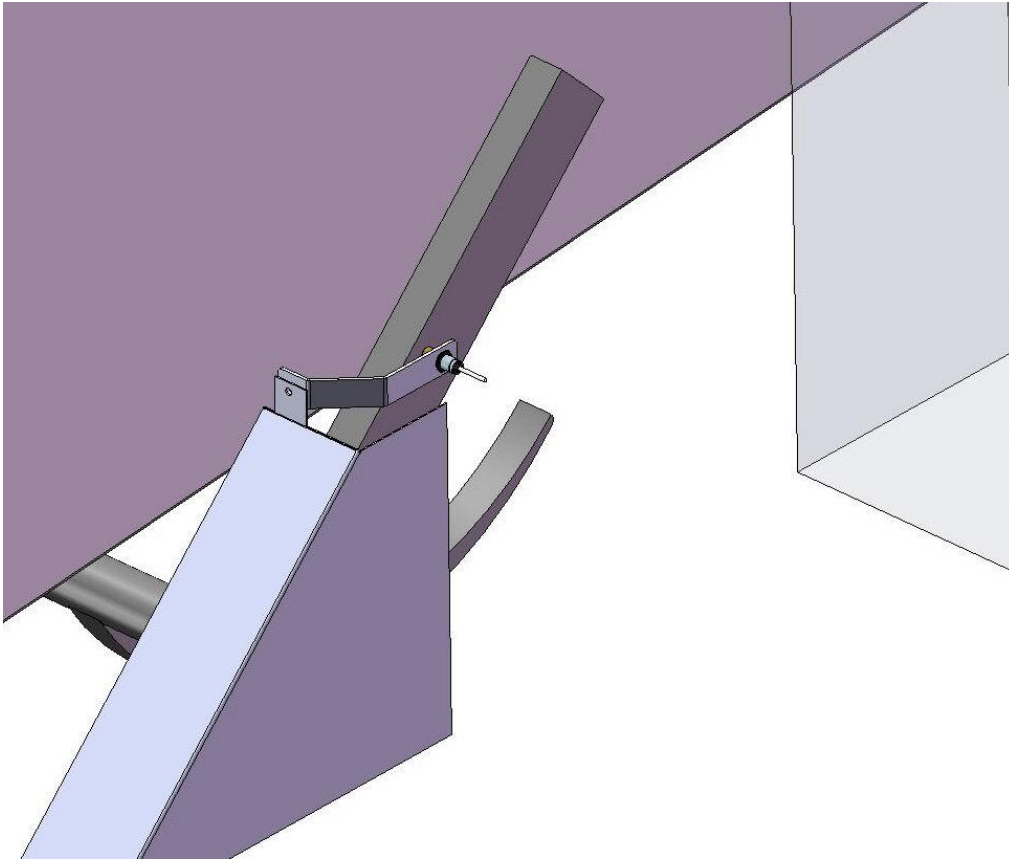

Mount the Krone end of bale sensor bracket (001-4648K2) as shown. The Krone mounting bracket can be found in the installation kit box. Directly behind the twine box on the right side of the baler remove the bolt and nut that secures the fiberglass baler shield to the baler. Mount the sensor bracket using the 3/8 x 1 bolt, lock and nut. Mount the sensor at the end of the bracket, keep the sensor 1/4" (7mm) from the needle and tighten both nuts. Run the sensor cable up to the Dual Channel Processor (DCP) and secure to the baler.

## All Kuhn, Vicon and Taarup Balers

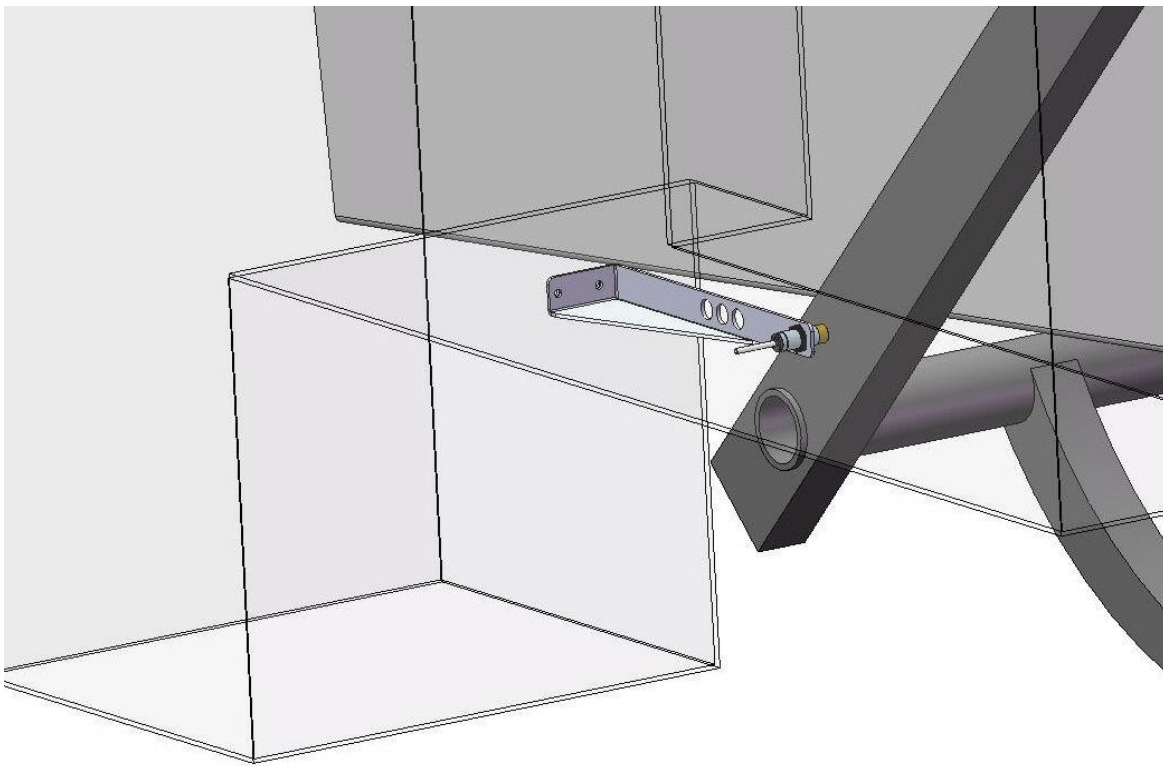

Mount the end of bale sensor bracket (001-4648) as shown. Mark and drill two 3/8" holes and attach the bracket using two 5/16" x 1" self-tapping screws, and 5/16" flange nuts. Mount the sensor in a hole location centered over the needle arm, keep the sensor 1/4" (7mm) from the needle and tighten both nuts. Run the sensor cable up to the Dual Channel Processor (DCP) and secure to the baler.

## Installation of the Drain/Fill Line

1. Locate parts bag 1.
2. Thread 3/4" elbow fitting into end of tank.
3. Run hose from the elbow down the frame to the bottom of the baler.
4. Drill 1/4" (7mm) holes to accept the valve holder bracket and use 5/16" x 1" self-tapping screws.
5. Connect valve assembly to other end of hose. Place hose clamps on both ends.
6. Secure hose to frame using cable locks.
7. Install supplied safety decals (DCL-8001 & DCL-8005) next to the ball valve assembly.

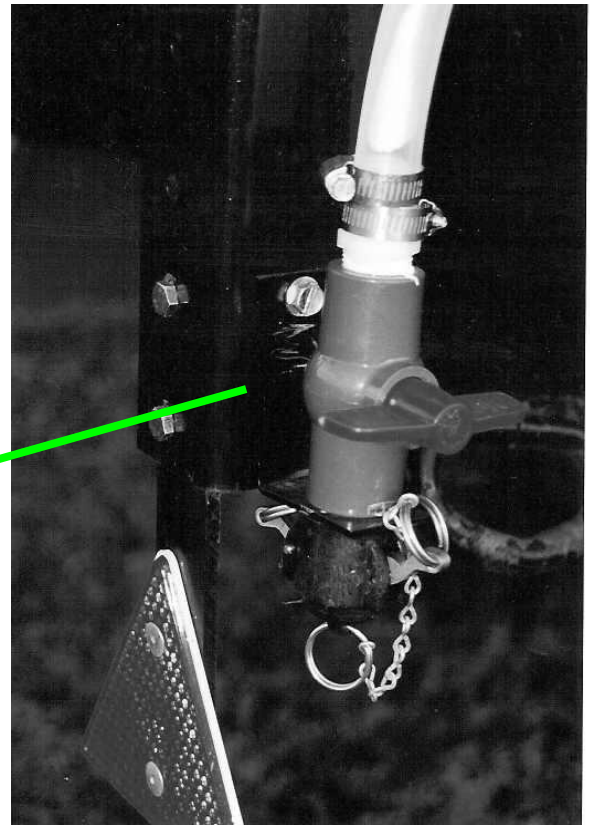
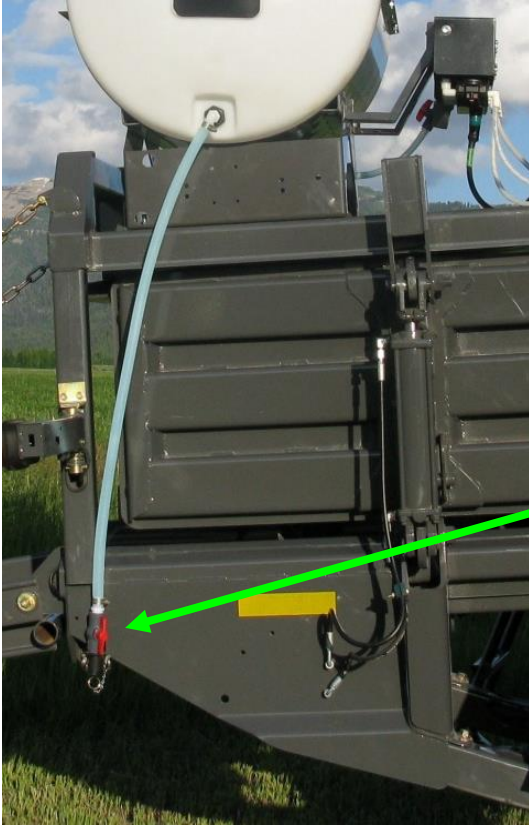

## Installation of Spray Shield

The spray shield assembly is designed to spray the hay evenly as the baler picks it up. A sketch of the spray shield nozzle holder is shown below.

### Tip Outputs

#### High Output Tips for Rates Requiring 84-632 lbs/hr (38-287 L/hr) . (Approximately 21-63 tons/hr)

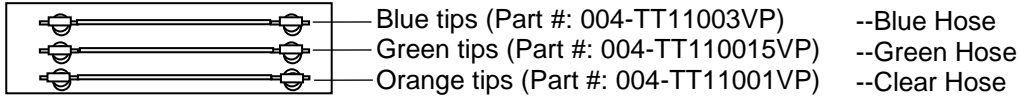

#### Install Kits 4537B, 4540B, 4541B

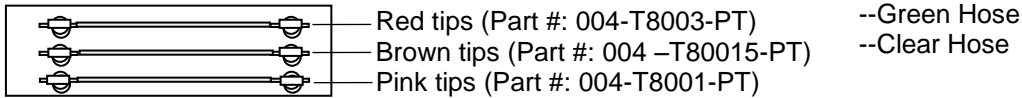

#### Low Output Tips for Rates Requiring 44-400 lbs/hr (19-200 L/hr). (Approximately 11-40 tons/hr)

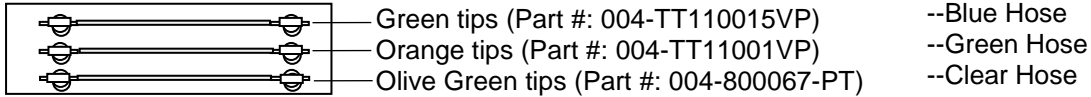

#### Install Kits 4537B, 4540B, 4541B

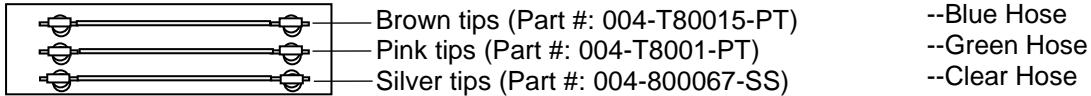

### Installation Kit 4438B

The spray shield is installed on the gathering fork guard located in the back of the pickup head. Existing bolts are used to fasten the spray shield bracket to the gathering fork guards. Route hoses so they will not interfere with moving parts. This can be checked by rotating the flywheel by hand. **Don't fasten hoses to metal hydraulic lines!** A parts breakdown is located in the back of the manual.

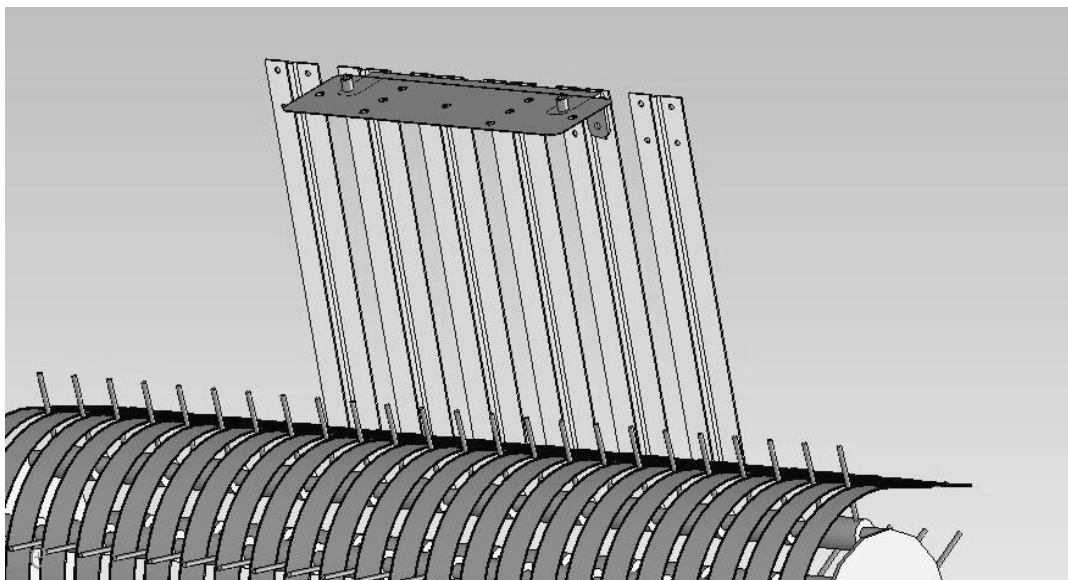

## Installation Kit 4439B

The spray shield is installed on the gathering fork guard located in the back of the pickup head. Existing bolts are used to fasten the spray shield bracket to the gathering fork guards. Route hoses so they will not interfere with moving parts. This can be checked by rotating the flywheel by hand. **Don't fasten hoses to metal hydraulic lines!** A parts breakdown is located in the back of the manual.

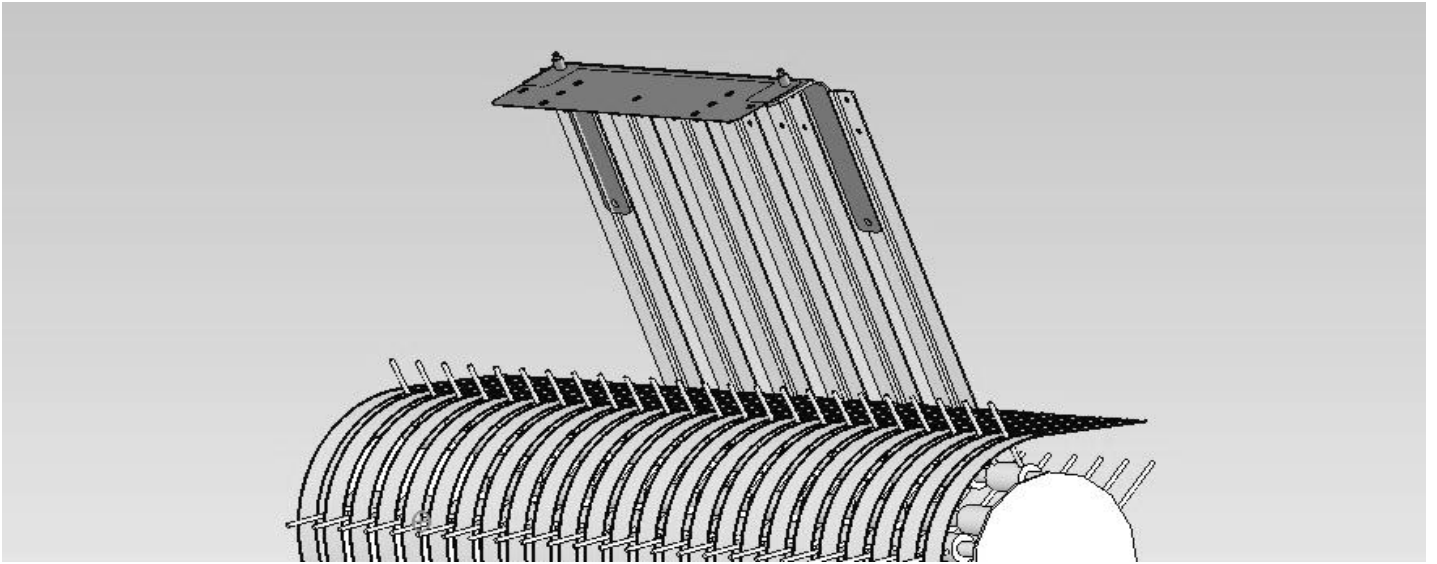

## Installation Kit 4490B

The spray shield holder will be installed underneath the baler's tongue. Bolt the right side up using the existing hole on the bottom lip of the baler. Use the clamp on the left hand side to tighten the shield against the underside of the tongue. Tighten the clamp with the two bolts provided. A parts breakdown of the 4490B is located in the back of this manual.

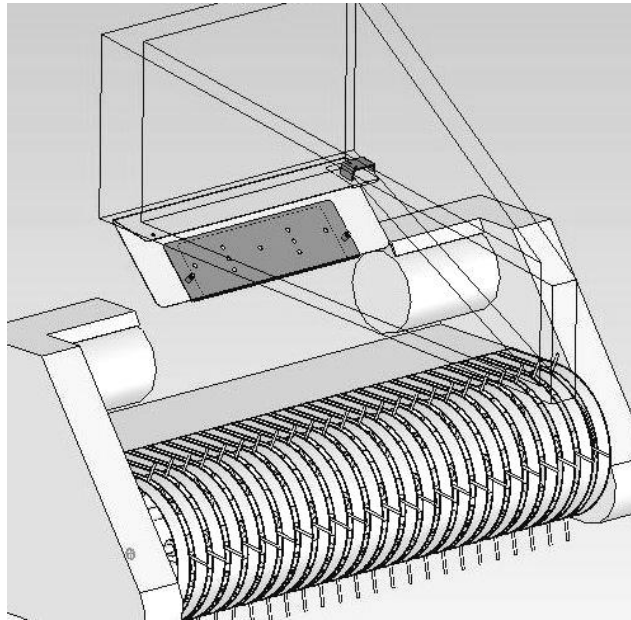



## Installation Kit 4491B

Install the spray shield behind the baler's cross channel, which is located on the bottom side of the tongue behind the flywheel. Note the position of the bevel on the spray shield. Clamp the spray shield around the channel using the backing plates and the 1/4" x 7" (7mm x 18cm) bolts provided. A parts breakdown of the 4491B install kit is shown in the back of this manual.

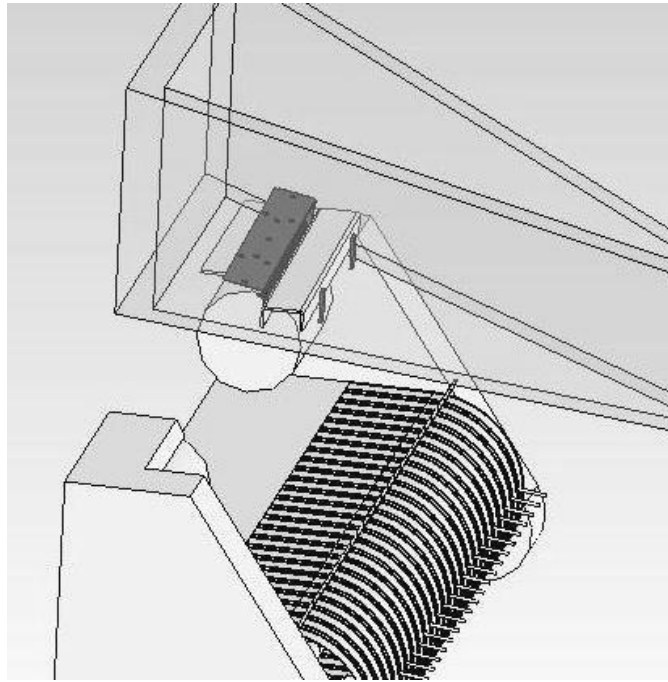

## Installation Kit 4492B

Remove the two 3/8" carriage bolts that connect the wrapper extension to the angle support on each side. Place the brackets 001-4436DL and 001-4436DR between the angle support and the wrapper extension. Replace the bolts with 3/8" x 1-1/4" carriage bolts, nuts, locks, and flat washers. Before tightening pull down on wrapper extensions so when tightened the bolts are in the top of the wrapper extension slot. Install the wind guard stops 001-4436S as shown below. Two holes will need to be drilled per side. Mount using four 1/4" x 1" bolts, locks and nuts.

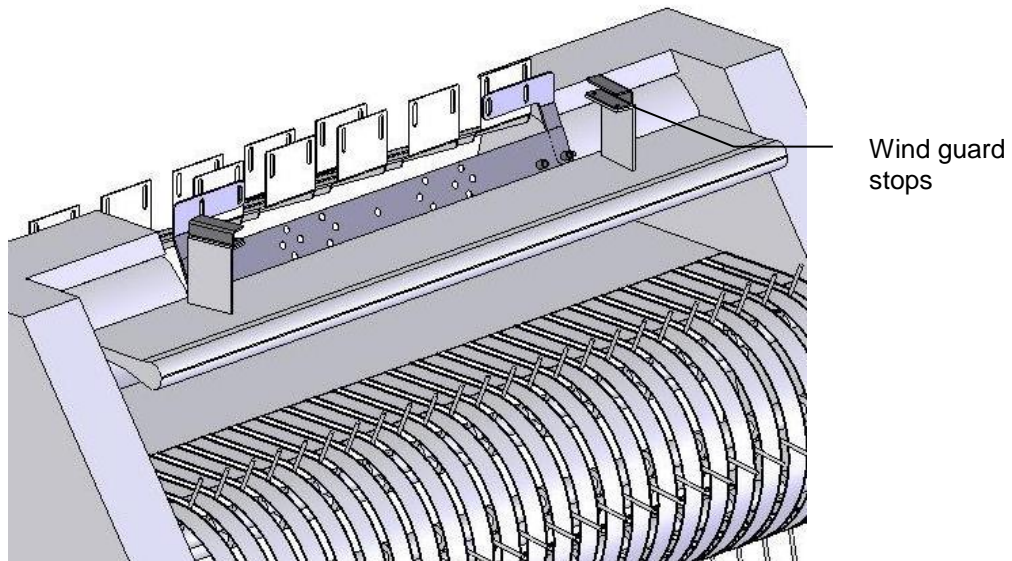



## Installation Kit 4494B

Remove the two 3/8" carriage bolts that connect the wrapper extension to the angle support on each side. Place the brackets 001-4436DL and 001-4436DR between the angle support and the wrapper extension. Replace the bolts with 3/8" x 1-1/4" carriage bolts, nuts, locks, and flat washers. Before tightening pull down on wrapper extensions so when tightened the bolts are in the top of the wrapper extension slot. Install the wind guard stops 001-4436S as shown below. Two holes will need to be drilled per side. Mount using four 1/4" x 1" bolts, locks and nuts.

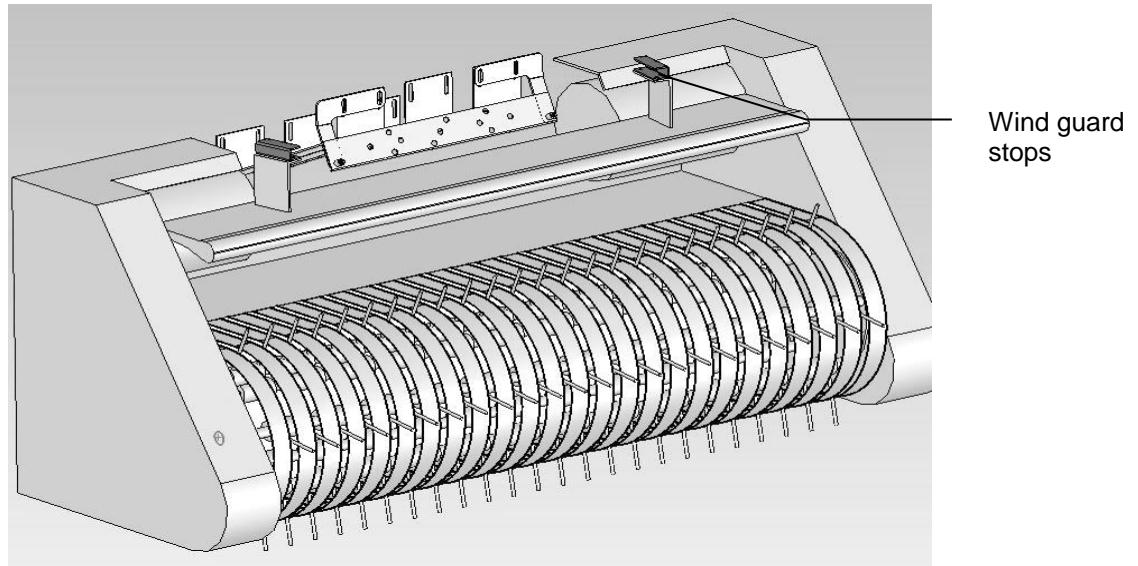

## Installation Kit 4495B & 4528B

**New Holland and Case:** Install the spray shield under the tongue of the baler, behind the flywheel. There are two existing bolt holes 6" - 12" (15cm-30cm) above the gathering fork guards, connect the spray shield using these holes. The tips should be pointing to the throat of the baler chamber. Install the wind guard stop as shown below 2" (51mm) behind the bend in the baler frame. A parts breakdown of the 4495B install kit is located in the back of the manual.

**Krone:** Install the spray shield under the tongue of the baler in front of the flywheel. You will need to drill two holes directly in front of the flywheel to secure the shield on the baler. The tips should be pointing to the throat of the baler chamber. A parts breakdown of the 4495B install kit is located in the back of the manual.

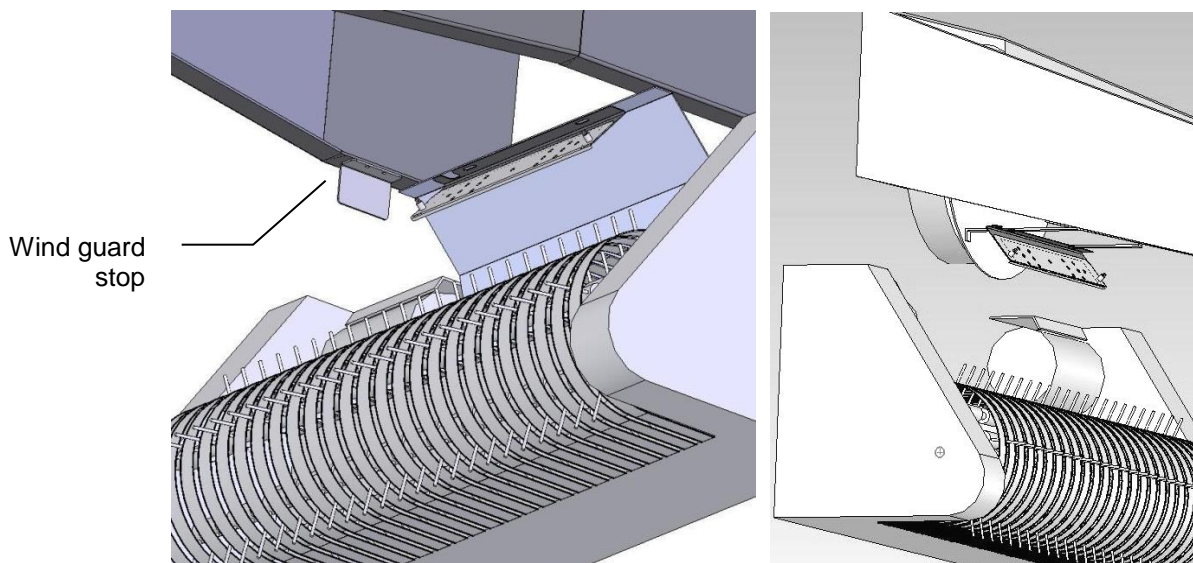

New Holland and Case

Krone

## Installation Kit 4497B & 4529B

Attach shield to cross member as shown in picture below. Center the shield above the rotor. Four holes will need to be marked and drilled. Use supplied 3/8" x 1-1/4" inch bolts, nuts, and lock washers to attach the shield holders (001-4435E) to the metal cross member directly above the rotor. Attach the spray shield (001-4435ES) to the holders and secure with lynch pins. **The shield is set up for 3X4 balers. Use the inside holes on the shield for 3X3 balers and the outside holes for 3X4 balers.**

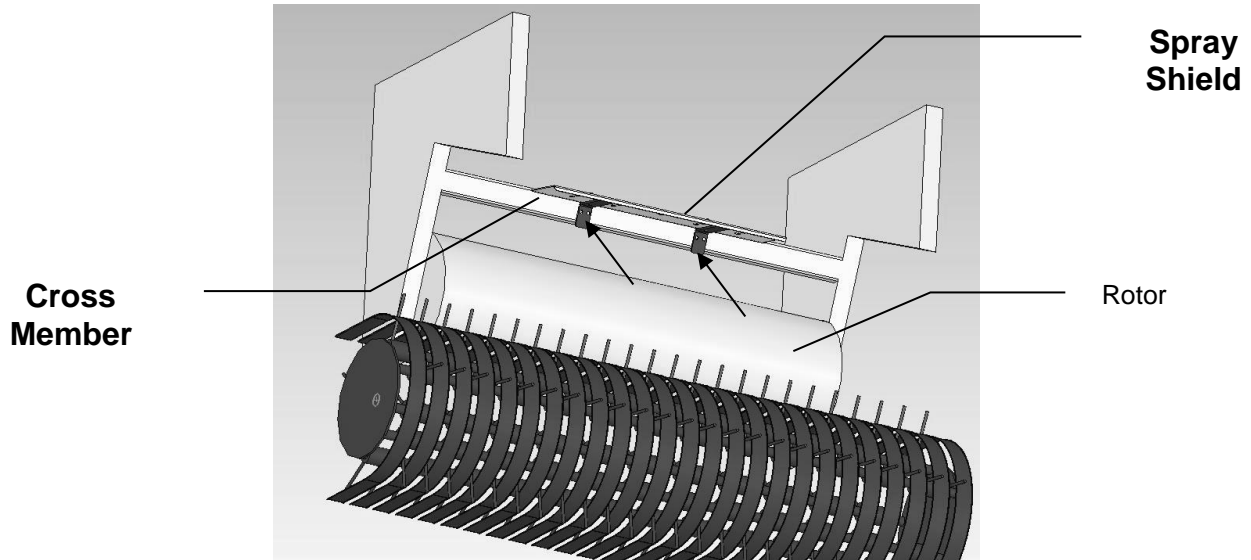

## Installation Kit 4498B

Lower the wind guard of the baler to maximize the installation working space. Locate the guards between the hay intake fingers. Hold the spray shield up so it straddles the top of the guards. Locate the holes on the baler that line up with the spray shield holders. Connect the spray shield to the baler using the existing bolts. Adjust the spray shield so it can be removed and reinstalled freely once the lynch pins are removed.

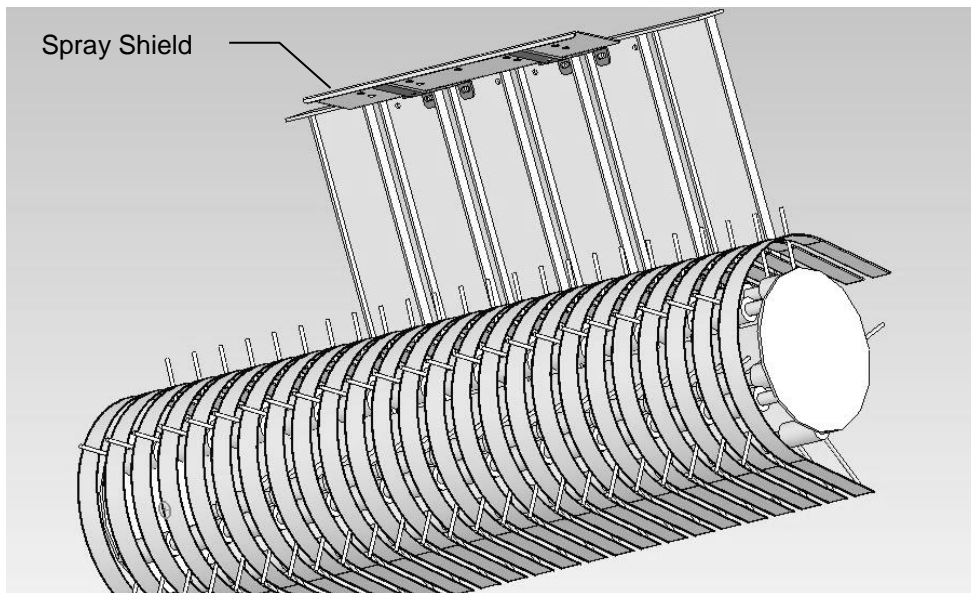

## Installation Kit 4499B

Install the spray shield-mounting bracket between the two flat vertical plates above the rotor as indicated in the picture below. Use the existing bolt holes with the hardware from the applicator kit to mount the spray shield bracket to the baler. Fasten the spray shield onto the spray shield bracket already mounted. Route hoses along the spray shield bracket towards the right side of the baler, and then back to the tank. When routing the hose avoid moving parts.

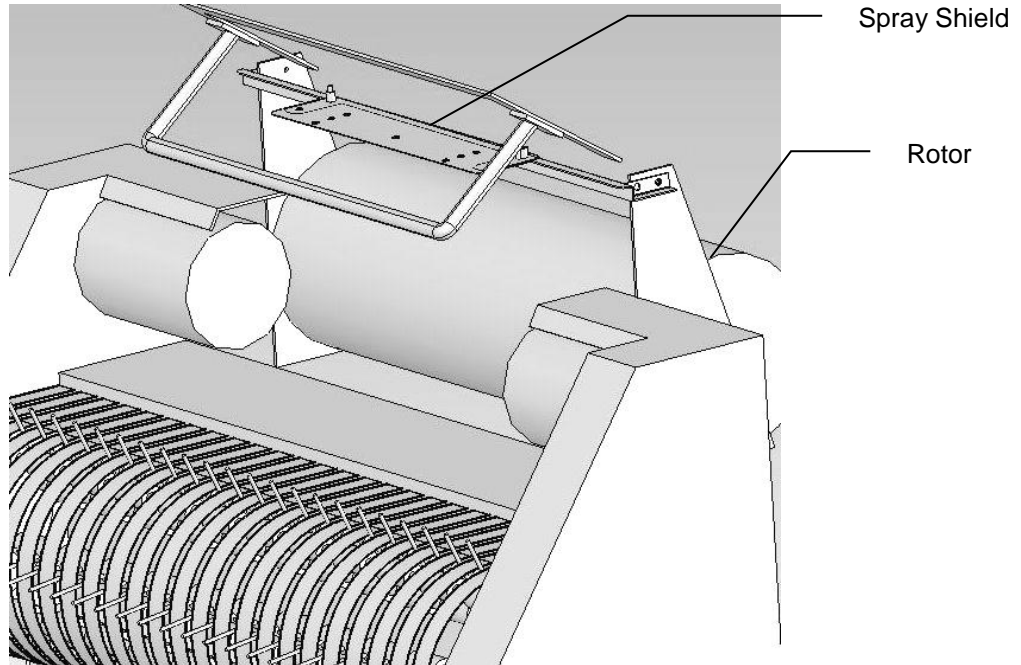

## Installation Kit 4500B

Locate the sheet metal above the top auger. (Figure 1) Locate the two holes through the sheet metal nearest the center of the pickup head. Place two  $\frac{3}{8}$ " x  $1\frac{1}{4}$ " bolts through the sheet metal with the bolt heads on the bottom side. Place 001-4436CR over the bolts and fasten with  $\frac{3}{8}$ " nuts, locks, and flat washers. Repeat for 001-4436CL on left side of machine. Place spray shield between brackets and tighten hardware.

Figure 1

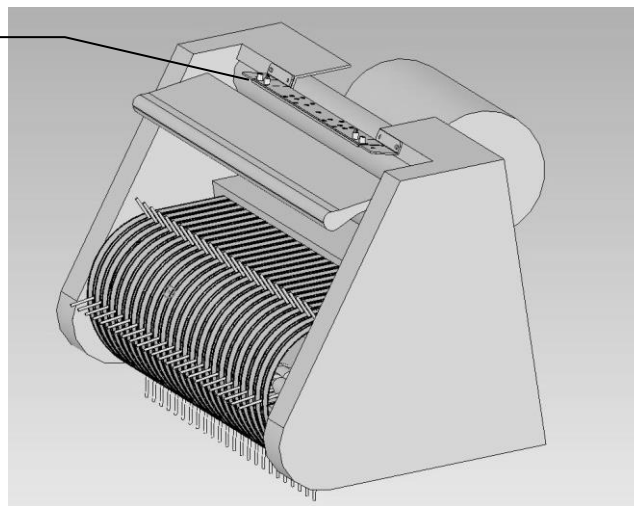

## Installation Kit 4501B

### 4790 cutter balers with top auger. (Figure 1)

Locate the sheet metal above the top auger. Locate the two holes through the sheet metal nearest the center of the pickup head. Place two 3/8" x 1-1/4" bolts through the sheet metal with the bolt heads on the bottom side. Place 001-4436CR over the bolts and fasten with 3/8" nuts, locks, and flat washers. Repeat for 001-4436CL on left side of machine. Place spray shield between brackets and tighten hardware.

### 4790 cutter balers without top auger. (Figure 2)

Connect spray shield to 001-4436CR and 001-4436CL brackets. Place the assembly across the top of the pickup head so the spray shield is horizontal. Center the shield over the throat of the baler directly above and centered over the bottom augers. Mark the holes on both sides and drill two 7/16" (12mm) holes on each side. Place two 3/8" x 1-1/4" through the sheet metal bolt heads down. Secure the assembly with 3/8" nut, locks, and flat washers.

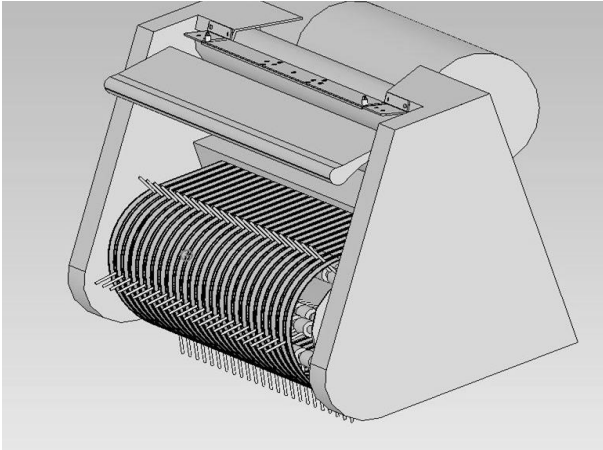

Figure 1

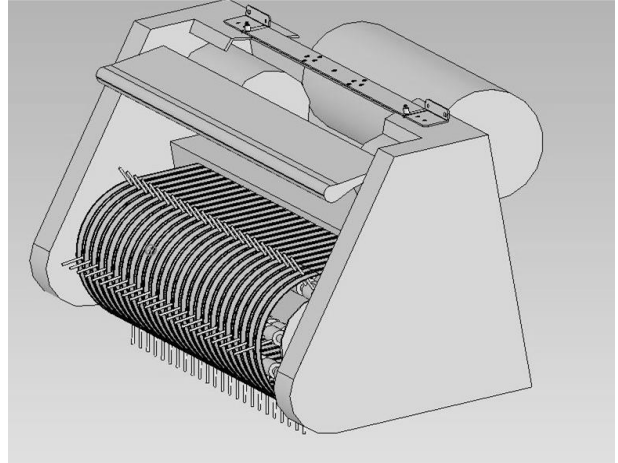

Figure 2

## Installation Kit 4509B

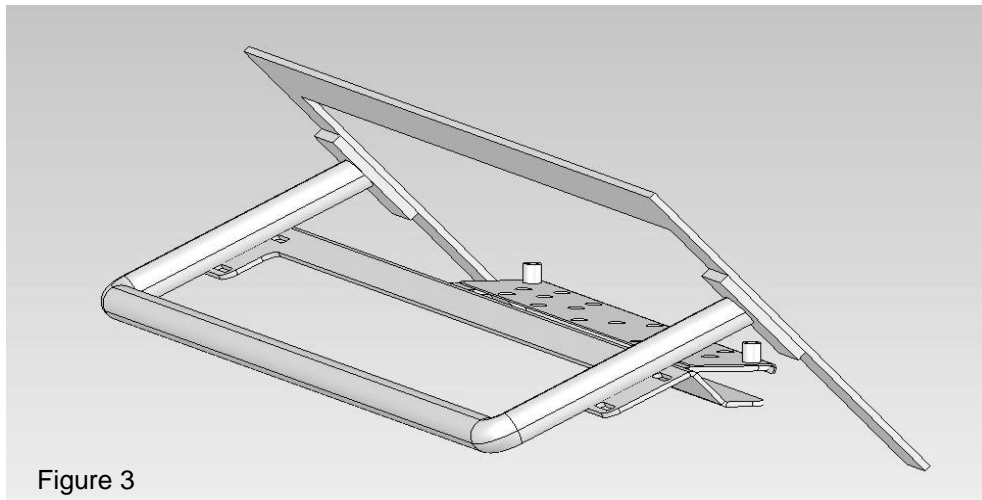
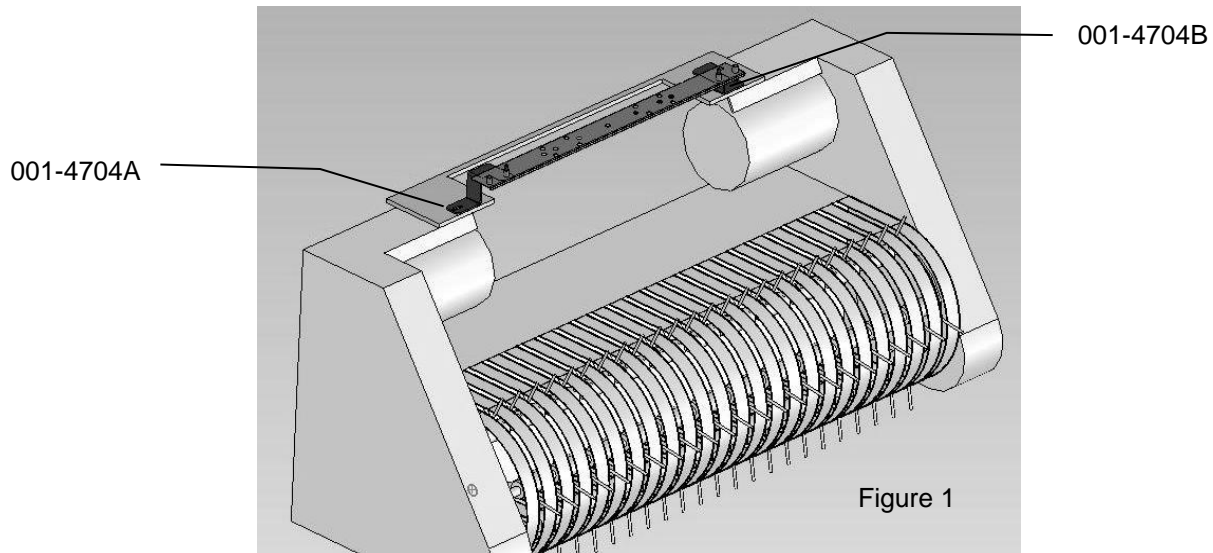

Figure 3

Locate the curved tube (Figure 3) above the auger and rotary cutting system. Attach Shield holder (001-4440A) using the four supplied U-bolts, nuts, flat and lock washers. Slide shield back as far as the baler will allow and tighten down all mounting hardware. Install spray shield (001-4810) and use the two lynch pins (008-4576) to secure.

## Installation Kit 4510B



Locate the sheet metal above the pickup head. (Figure 1) Connect spray shield to 001-4704A and 001-4704B brackets. Place the assembly across the top of the pickup head so the spray shield is horizontal. Center the shield over the throat of the baler directly above and centered over the bottom augers. Mark the holes on both sides and drill two 7/16" (12mm) holes on each side. Place two 3/8" x 1-1/4" through the sheet metal bolt heads down. Secure the assembly with 3/8" nut, locks, and flat washers.

## Installation Kit 4511B

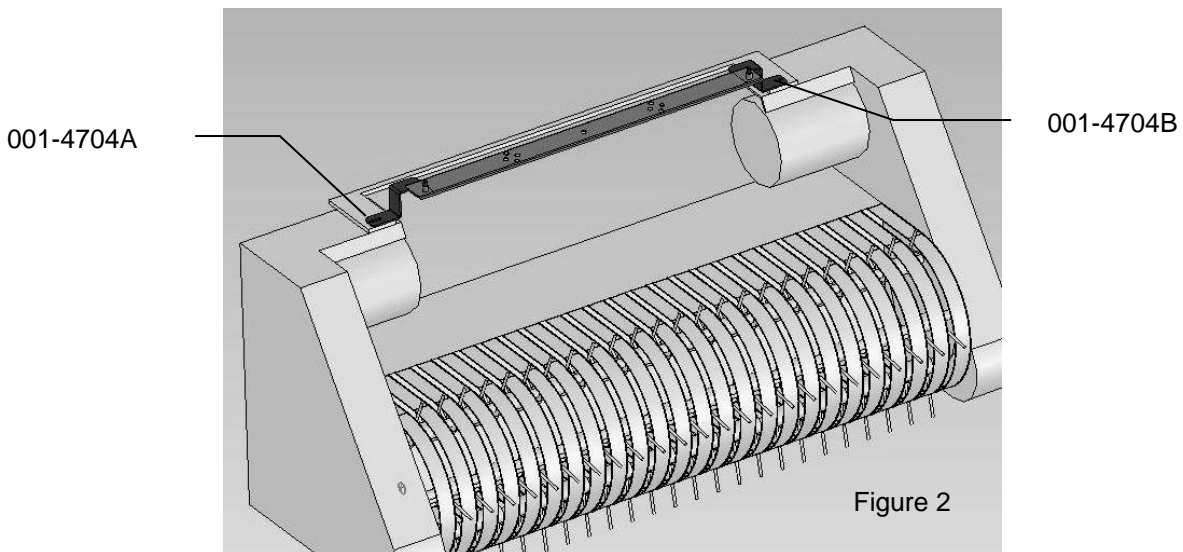

Locate the sheet metal above the pickup head. (Figure 2) Connect spray shield to 001-4704A and 001-4704B brackets. Place the assembly across the top of the pickup head so the spray shield is horizontal. Center the shield over the throat of the baler directly above and centered over the bottom augers. Mark the holes on both sides and drill two 7/16" (12mm) holes on each side. Place two 3/8" x 1-1/4" through the sheet metal bolt heads down. Secure the assembly with 3/8" nut, locks, and flat washers.



## Installation Kit 4514B

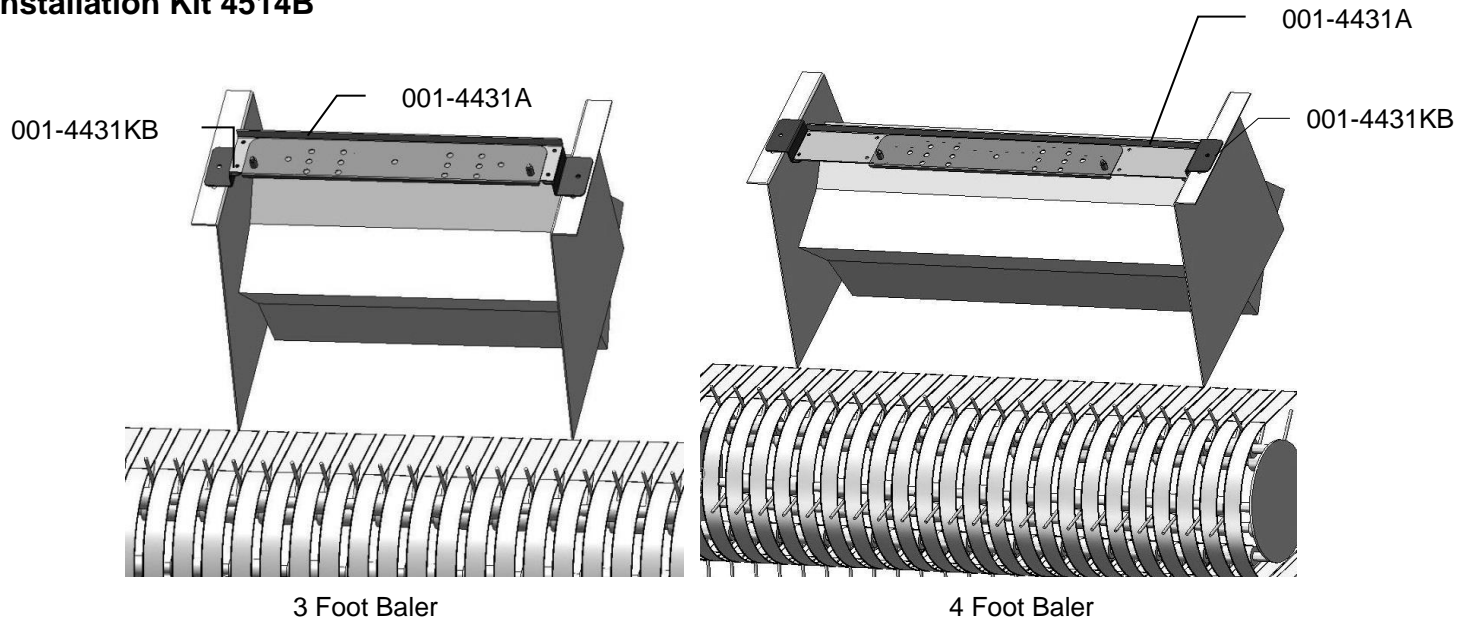

Locate the two mounting brackets (001-4431KB). In the 4' baler, these brackets are positioned so the spray shield is dropped down from the flywheel. On the 3' baler, these brackets are positioned using the top hole on each side to raise the spray shield up from the rotor. Use the top hole on the baler for mounting the brackets. These brackets will be secured with two 3/8" x 1" bolt and flats, locks, and nuts. Then the spray shield holder (001-4431KA) spans across the throat of the baler and bolts to mounting brackets so the pins are on the top side. The holder has a formed flange on the backside that should be flush with the back of the mounting brackets. The shield holder will be fastened to the mounting brackets with four 5/16x1" bolts with flats, locks and nuts (2 on each side). In the case of the 3' (1M) balers there are additional holes for mounting the holder to the brackets. For 3' (1M) wide balers 7-1/2" (19cm) will need to be cut off the ends the shield holder. Place the spray shield assembly on top of the shield holder and secure with lynch pins.

## Installation Kit 4515B

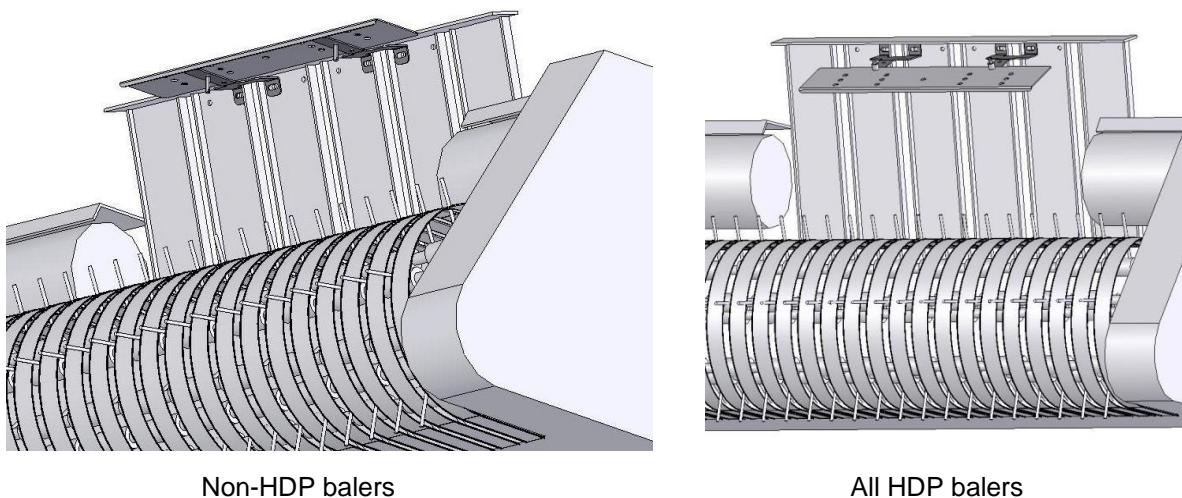

Locate the four center stuffer guards (on narrower models of baler, there may be only four stuffer guards). Remove the nuts and bolts indicated above that fasten the stuffer guards to the cross member above the baler throat. Replace the hardware that you removed with the hardware included in the parts bag (M10x30 bolts, M10 lock washers, and M10 nuts) and bolt the spray shield holder (001-4435KS) in place as shown above. Use the above pictures to determine the position of the spray shield holder depending on baler type. Position the spray shield (001-4435AS) on top of the spray shield holders with the pins from the spray shield holder extending through the pipes welded to the spray shield. Adjust the spray tips so they point towards the throat of the baler. Adjust the spacing of the spray shield holder as needed and tighten the hardware.

## Installation Kit 4525B

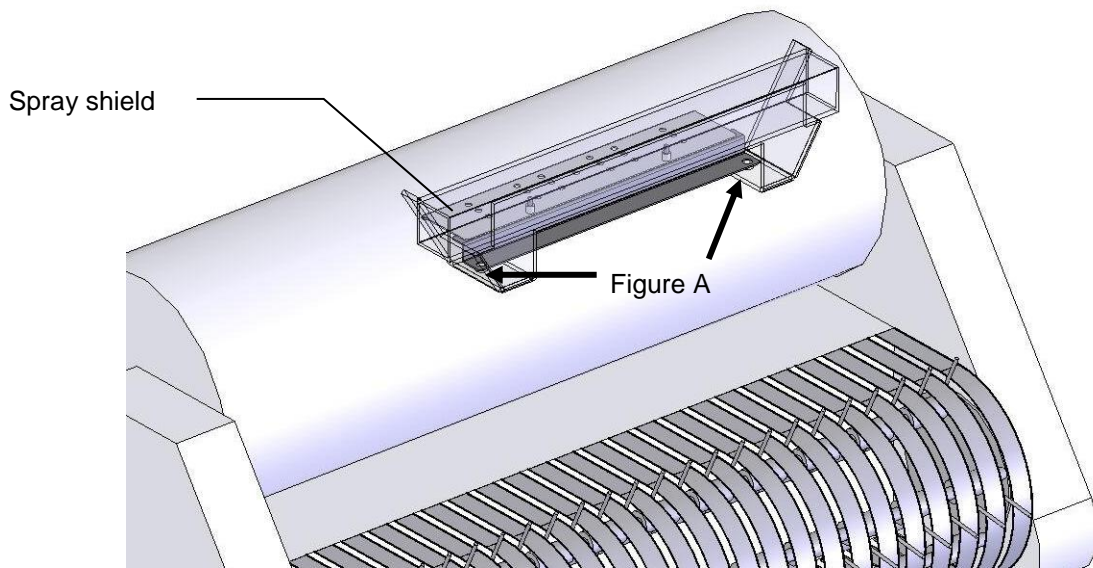

Locate the two bolts show in Figure A. Remove bolts and install spray shield holder (001-4435EK). Install bolts and tighten. Install spray shield assembly (001-4435ES) and secure with two supplied lynch pins. Use the inside slots on 3x3 balers and the outside slots on 3x4 balers.

## Installation Kit 4537B

The spray shield holder (001-4435L) is centered on the L-shaped bracket above the rotor and secured with 3/8"x1-1/4" hex bolts, 3/8" lock washers, and 3/8" nuts (x3). The spray shield is then pinned in place with the lynch pins. Route hoses so they do not interfere with moving parts, and do not fasten hoses to hydraulic lines.

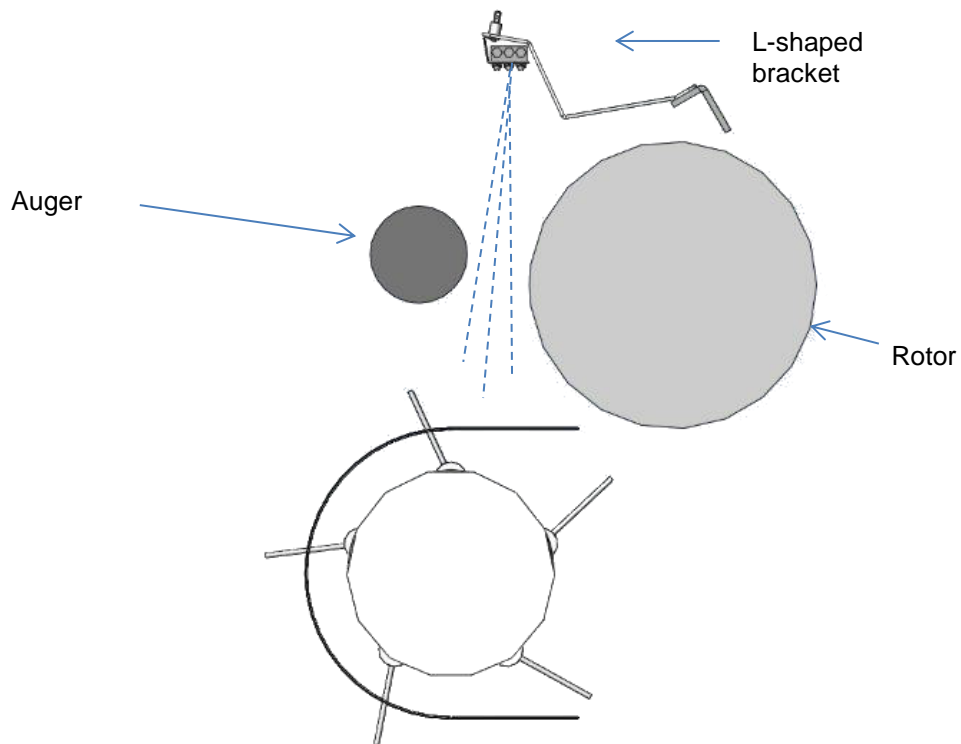
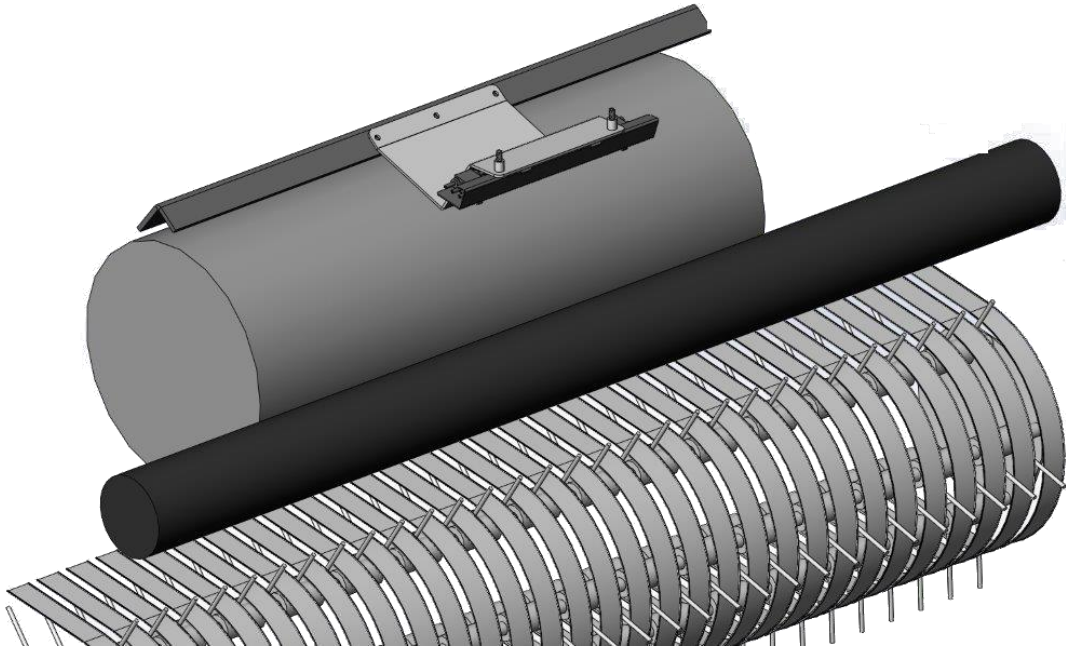



## Installation Kit 4539B

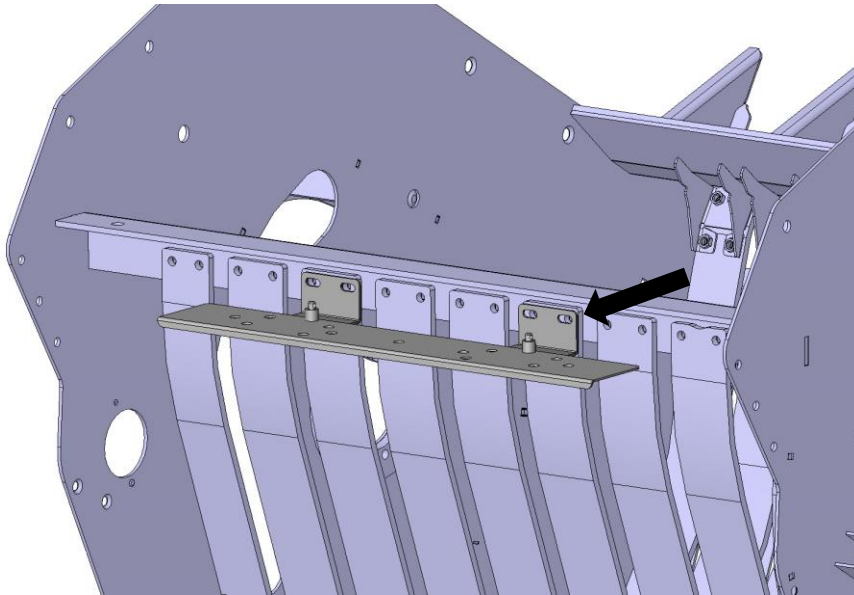

Locate the center stuffer guards and remove the nuts and bolts indicated above that fasten the stuffer guards to the cross member above the baler throat. Replace the hardware that you removed with the hardware included in the parts bag (M10x30 bolts, M10 lock washers, and M10 nuts) and bolt the spray shield holder (001-4435KX) in place as shown above. Use the above pictures to determine the position of the spray shield holder depending on baler type. Position the spray shield (001-4435AS) on top of the spray shield holders with the pins from the spray shield holder extending through the pipes welded to the spray shield. Adjust the spray tips so they point towards the throat of the baler

## Installation Kit 4540B & 4541B

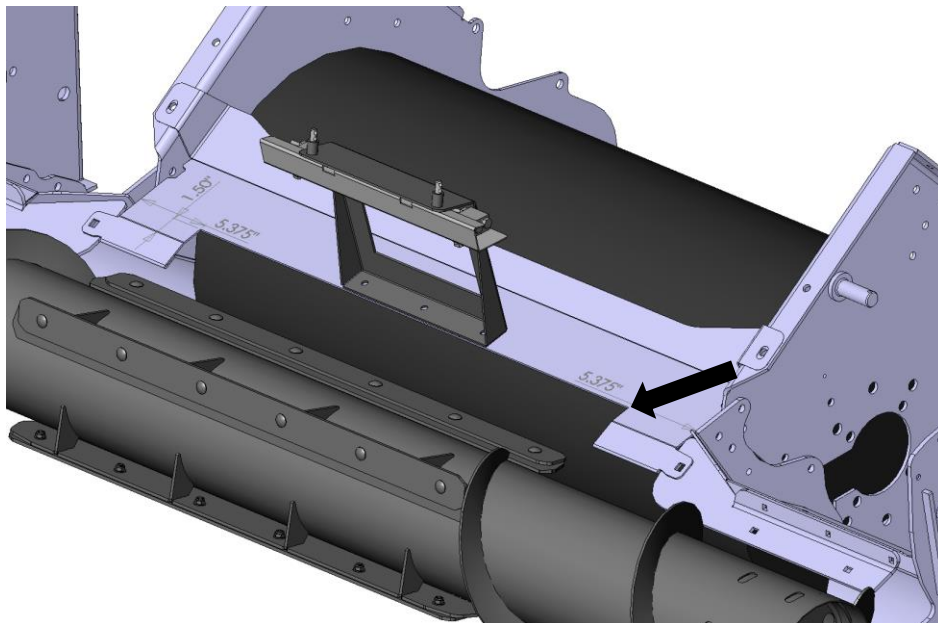

A piece of the guard above the rotor will need to be removed before mounting the spray shield holder (001-4435KC). Measure in 5 3/8" from each side of the guard and 1 1/2" (38mm) deep as indicated in the picture above. The shield holder is centered above the area above the piece that was removed. The spray shield is then pinned in place with the lynch pins. Route hoses so they do not interfere with any moving parts, and do not fasten hoses to hydraulic lines.

## Plumbing

- Locate the three 1/4" hoses colored clear, blue, and green. The pumps will need to be connected to specific tips so the pump numbers are as follows: Pump 1 is closest to the filter bowl, pump 2 is in the middle, and pump 3 is the outside pump.
- Slide the jaco nut over the end the hose and insert the hose into the jaco fitting and tighten the jaco nut. Because all nozzles on the spray shield are different, the operator will need to install pump 1 to the orange tips using the clear hose, pump 2 to the green tips using the green hose and pump 3 to the blue tips using the blue hose.
- KEEP HOSE AWAY FROM: MOVING PARTS, SHARP METAL, AND HYDRAULIC LINES. WORKING TEMPERATURE FOR THE HOSE IS 140 °F AND UNDER.**
- Tie the hose down at secure locations on the baler using the enclosed tie straps and cable clamps.

### High and Low Output Tips

Your baler comes with two sets of tips: a low set and a high set. The high set comes factory installed.

#### High Output Tips for Rates Requiring 84-632 lbs/hr (38-287 L/hr). (Approximately 21-63 tons/hr)

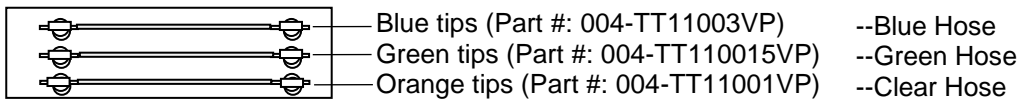

#### Install Kits 4537B, 4540B, 4541B

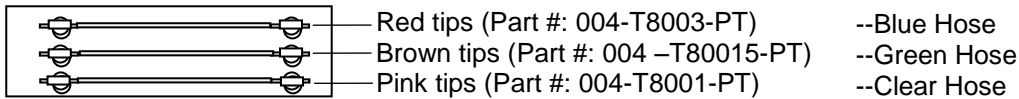

#### Low Output Tips for Rates Requiring 44-400 lbs/hr (19-200 L/hr). (Approximately 11-40 tons/hr)

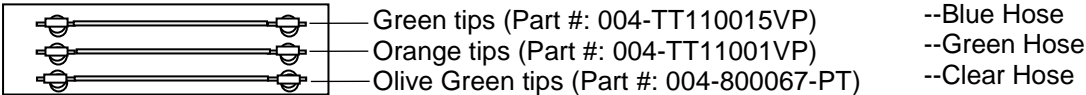

#### Install Kits 4537B, 4540B, 4541B

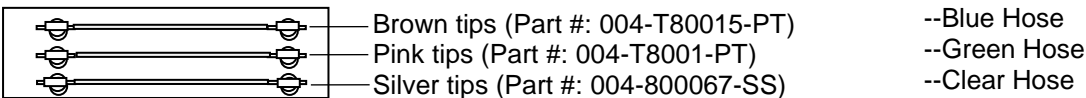

**\*\*Refer to Tip Output under APPLICATION RATE of the control unit to calibrate system.**

## Installation of star wheel and bale rate harness

Remove the cover from the star wheel block and use a 1/4" nut driver to remove the nut from the electronic swivel. Next, run the star wheel sensor wire through the black grommet and place the eye terminal on the star wheel sensor. Tighten the eye loop with the nut on the sensor and put the star wheel cover back on the base. Tighten the grommet to form a tight seal around the wire. The bale rate sensors will be factory installed on the right side twine guard in the correct position. The sensor with the longer sensor wire should say "FRONT" which indicates it should be placed in the front sensor hole. The sensor wire with the shorter wire should say "BACK." The tip of the sensor should be placed no more than 1/4" (7mm) away from the star wheel teeth and no less than 1/8" (3mm) from the star wheel teeth. Each sensor will have an LED light located on the sensor by the diverter. Once the unit is powered up spin the wheel and make sure that both led lights turn on and off. If they don't turn on and off, adjustments may need to be made. Once the star wheel connection is complete, run the harness along the baler frame to the Dual Channel Processor (DCP). See wiring installation on the following page. The Dual Channel Processor is located on the back of the right twine box.

## Main wiring harness and power cord connection to baler harness terminator connection.

Route cords 006-6650LS2 along this path or similar inside of the baler. Keep cords away from moving parts and hydraulic hoses. Secure with existing cable clamps or use cable ties. When all connections are made to DCP secure wires.

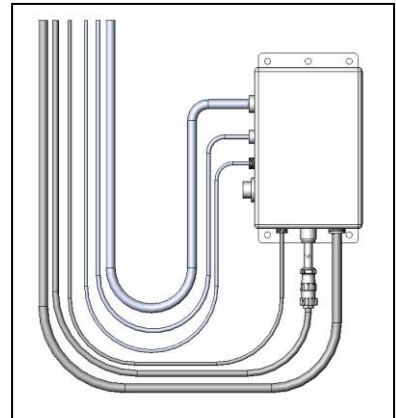

## Installation of Bluetooth Receiver

Locate a safe location in the cab of the tractor to place the Bluetooth Receiver (030-6672A). Recommended location is as close to the iPad being used as possible.

Connect the Power / Communication harness (006-6650TM) to the bottom of the receiver (right).



## Connecting the optional ISOBUS plug to the tractor

Attach the optional ISOBUS connector (006-6670A) to the end of the communication harness (006-6650TM).

Connect the orange wires and attach the plug to the tractor's ISOBUS port.

Then connect the ISOBUS connector to the ISOBUS plug on the tractor.

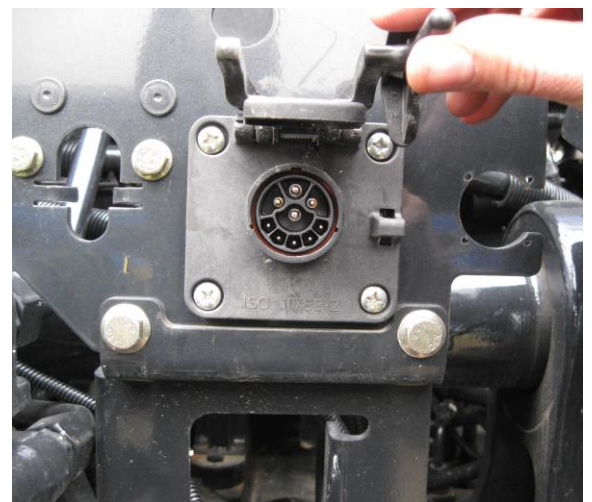

## Wiring Diagram

- 1 The **Baler Power/Communication Harness** (006-6650LS2) will attach to the open port of the **Tractor Harness** (006-6650TM) and run back to the **Dual Channel Processor** (006-6671LS). Connect the large plug of the Baler Power/Communication Harness (006-6650LS) to the bottom (shorter side) of the DCP.
- 2 Install green terminator (006-5650Z) to the port labeled **Modular Port** on the Pump Controller (006-5672).
- 3 Attach moisture and bale rate harness 006-7303H (Claas & Krone kits 006-7303HX) as well as the end of bale harness (006-7400) to the DCP (006-6671LS).
- 4 Attach the Pump Control Harness (006-5650FM) between the Pump Controller (006-5672) and the DCP (006-6671LS).
- 5 Connect the orange wires and attach the plug to the tractor's ISOBUS port.
- 6 If using the optional ISOBUS connector (006-6670A) connect the end to the Communication Harness (006-6650TM) in place of the Bluetooth Receiver shown below.
- 7 Connect the orange keyed power wires (006-5650K) and attach the plug to the tractor's ISOBUS port.

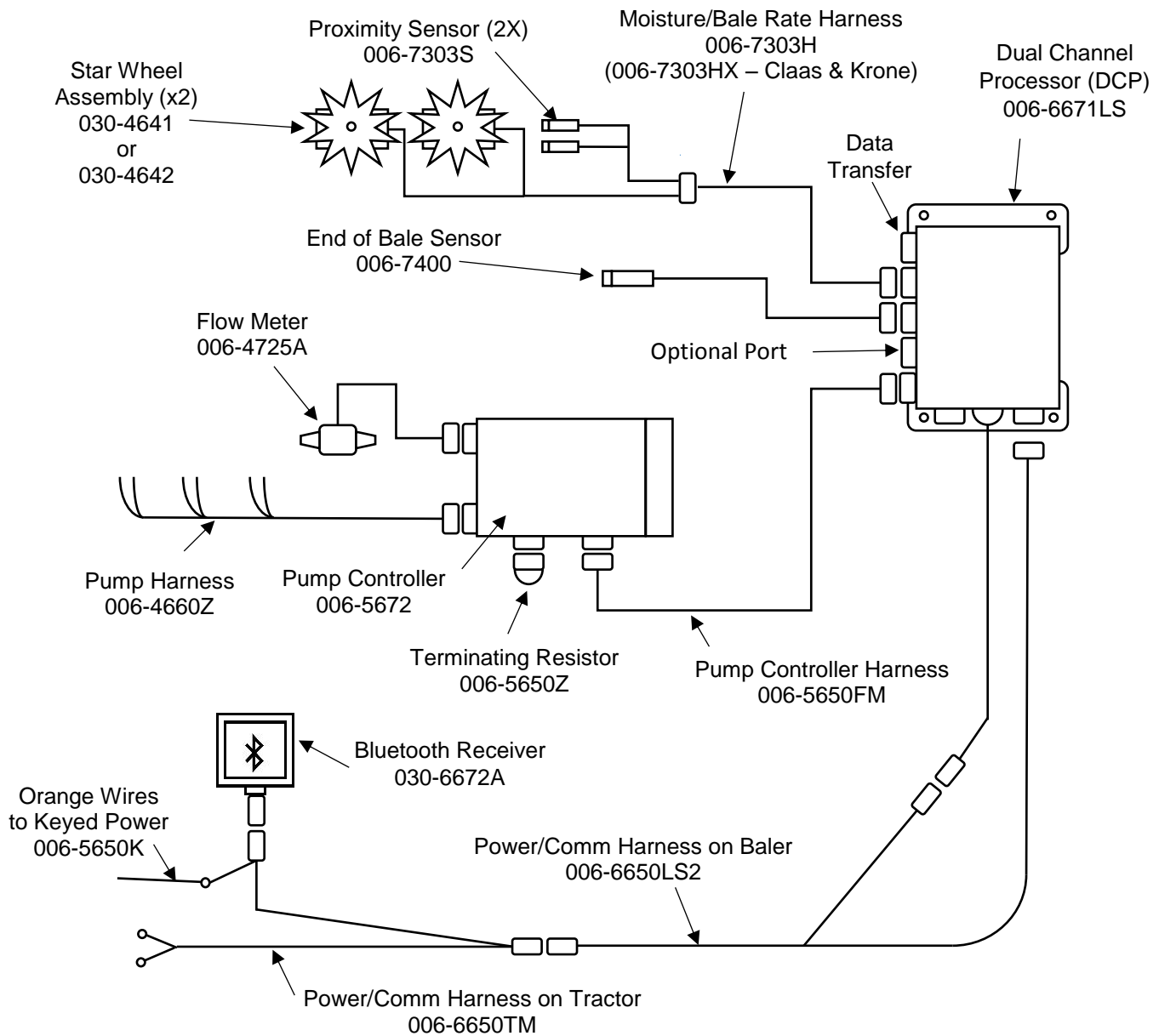

\*Claas 3200-3400 balers will have star wheel assembly 030-4642 for mounting on side of bale chamber

## Pin Outs

### Power/Comm Harness 006-6650TM at Hitch

Pin 1	Red	+12V Power to TSD
Pin 2	Red	+12V Power to DCP
Pin 3	Orange	Keyed Power
Pin 4	Gray	Shield
Pin 5	Green	HT Can Low
Pin 6	Yellow	HT Can Hi
Pin 7	Orange	Can1 Hi
Pin 8	Black	Ground from TSD
Pin 9	Black	Ground from DCP
Pin 10	Blue	Can1 Low



### Power/Comm Harness 006-6650LS2 at Hitch

Pin 1	Red	+12V Power to TSD
Pin 2	Red	+12V Power to DCP
Pin 3	Orange	Keyed Power
Pin 4	Gray	Shield
Pin 5	Green	HT Can Low
Pin 6	Yellow	HT Can Hi
Pin 7	Orange	Can1 Hi
Pin 8	Black	Ground from TSD
Pin 9	Black	Ground from DCP
Pin 10	Blue	Can1 Low



### Bluetooth Receiver on Harness 006-6650TM

Pin 1	Red	+12V Power from DCP
Pin 2	Black	Ground from TSD
Pin 3	Yellow	HT Can Low
Pin 4	Gray	Shield
Pin 5	Green	HT Can Hi
Pin 6	Orange	Can1 Hi
Pin 7	Blue	Can1 Low



### ISOBUS Plug Baler Side

Pin 1	N/A	
Pin 2	N/A	
Pin 3	120 OHM with Pin 5	
Pin 4	N/A	
Pin 5	120 OHM with Pin 3	
Pin 6	Orange	Can1 Hi
Pin 7	Blue	Can1 Low



### ISOBUS Plug Tractor Side

Pin 1	N/A	
Pin 2	N/A	
Pin 3	+12V Keyed Tractor Power	
Pin 4	N/A	
Pin 5	N/A	
Pin 6	N/A	
Pin 7	N/A	
Pin 8	Orange	Can1 Hi
Pin 9	Blue	Can1 Low

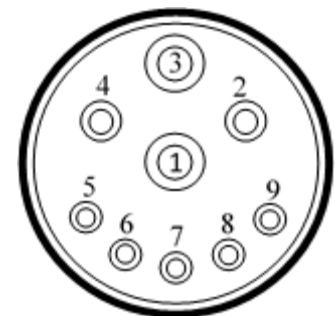

## Pin Outs (continued)

### Main Power Connector on DCP

Pin 1	Red	+12V Power from tractor
Pin 2	Black	Ground from tractor
Pin 3	Orange	Keyed power

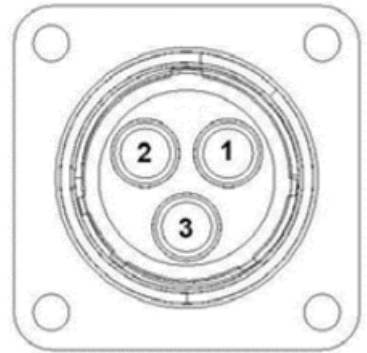

### Star Wheel and Bale Rate Sensor connector on DCP

Pin 1	Blue	+12V Power
Pin 2	Orange	Ground
Pin 3	Black	Signal for sensor 1
Pin 4	White	Signal for sensor 2
Pin 5	N/A	
Pin 6	N/A	
Pin 7	N/A	
Pin 8	Violet	Star wheel input 1
Pin 9	Brown	Star wheel input 2



### End of Bale sensor on DCP

Pin 1	Brown	Sensor Power
Pin 2	Blue	Sensor Ground
Pin 3	N/A	
Pin 4	Black	Signal from Sensor

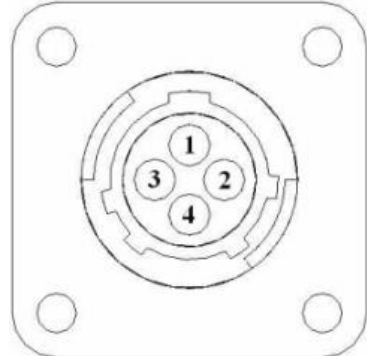

### Pump Connection Colors

Pin 1	Black with Orange Stripe	Pump 1 Ground
Pin 2	Black with Green Stripe	Pump 2 Ground
Pin 3	Black with Yellow Stripe	Pump 3 Ground
Pin 4	N/A	
Pin 5	Orange with Black Stripe	Pump 1 Positive
Pin 6	Green with Black Stripe	Pump 2 Positive
Pin 7	Yellow with Black Stripe	Pump 3 Positive

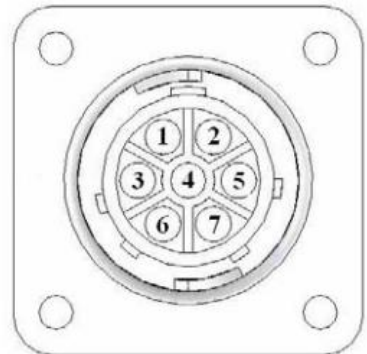



## Pin Outs (continued)

### Pump Communication Plug on DCP

Pin 1	Red	+12V Can
Pin 2	Red	+12V Power
Pin 3	Gray	Shield
Pin 4	Green	Comm Channel OH
Pin 5	Yellow	Comm Channel OL
Pin 6	Blue	Comm Channel IH
Pin 7	Orange	Comm Channel IL
Pin 8	Black	Can Ground
Pin 9	Black	Power Ground
Pin 10	N/A	

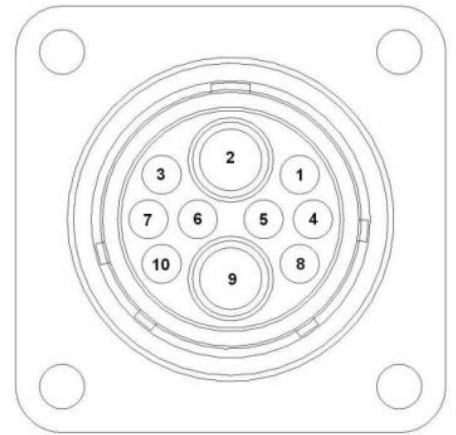

### Flow Meter Connection on Pump Controller

Pin 1	White	5 – 12V (+) Supply
Pin 2	Green	Ground
Pin 3	Brown	Signal
Pin 4	Black	Shield

51

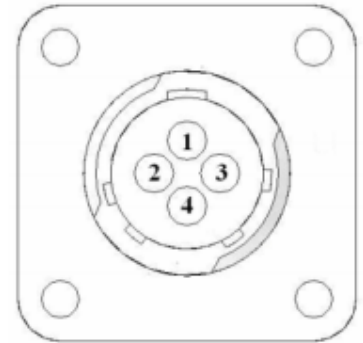

### Connector for Crop Eyes on DCP

Pin 1	Red	+12V Power
Pin 2	Black	Ground
Pin 3	White	Signal
Pin 4	N/A	

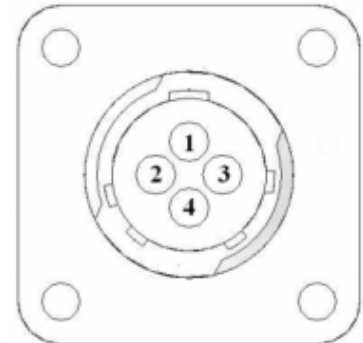

### 006-6650VAJ Harness to Baler Plug

Pin A	N/A	
Pin B	Red	TBC Power
Pin C	N/A	
Pin D	Gray	TBC Ground
Pin E	Orange	Can1 Hi
Pin F	Blue	Can1 Low

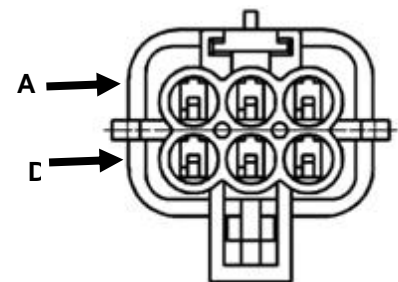



# Parts Breakdown Tank, Saddle & Legs 100 Gallon

Vermeer, Claas, and Krone Balers with 100 gallon tank

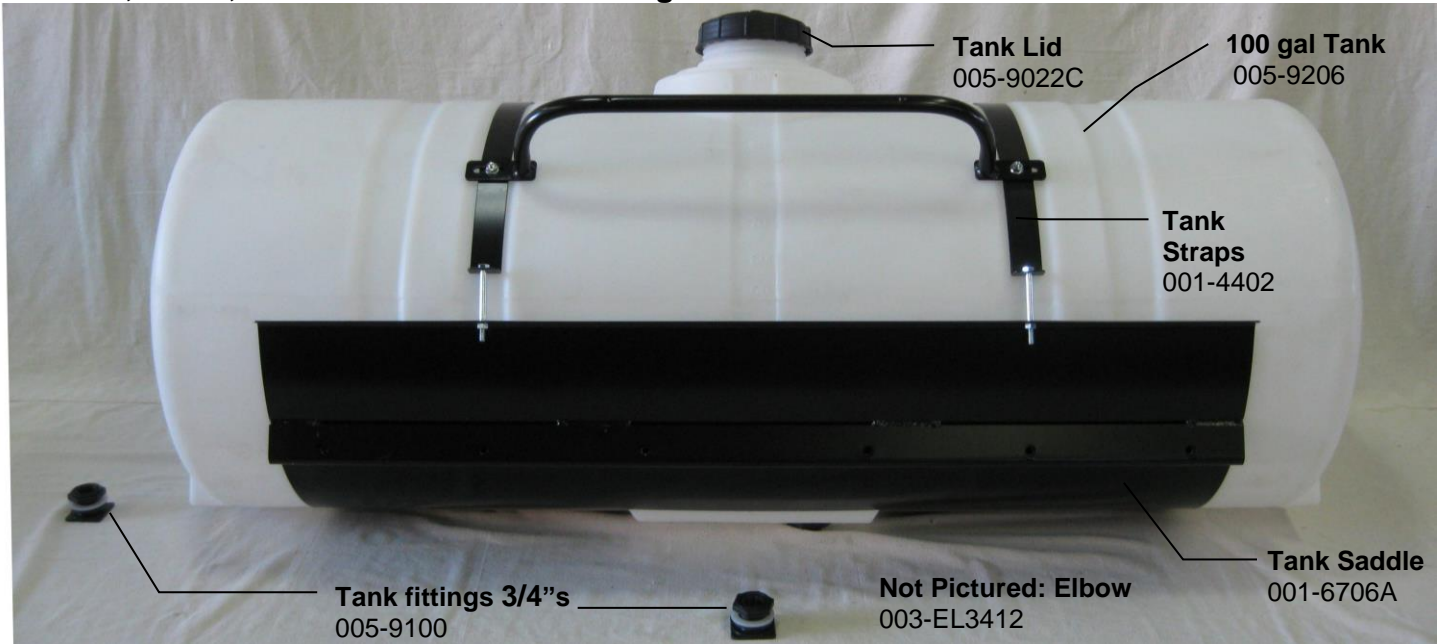

## Vermeer, Claas and Krone Balers Saddle Legs

Part#: 001-6706V

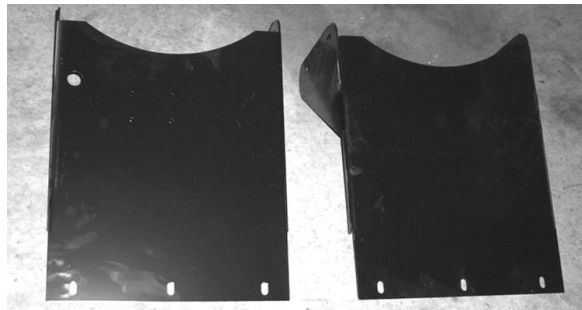

\*If the applicator is being mounted on a **Krone 870 HDP** baler, two leg adapter brackets will be needed for proper tank leg installation (below). Part number 001-6707KV.

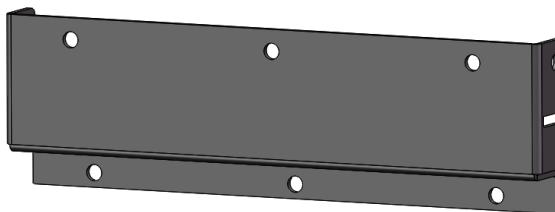

## Claas 3300 Saddle Legs

Part #: 001-6706C



## Tank, Saddle and Legs 110 Gallon



- Tank Lid**  
Part#: 005-9022E  
or 005-9208L
- Tank-110 gallon**  
Part#: 005-9208
- Hand Rail**  
Part#: 001-6707HR
- Tank Straps**  
Part#: 001-4402B
- Tank Saddle**  
Part#: 001-6707A
- Tank Fitting**  
Part#: 005-9100

**Not Pictured: Elbow**  
Part#:003-EL3412

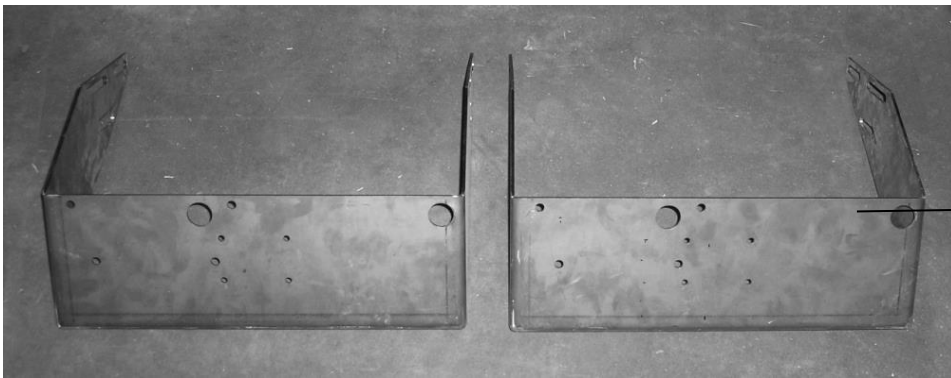

**Agco, Hesston, Massey & Challenger Saddle Legs**

Part#: 001-6707C

**New Holland BB940A, BB960A,  
Case IH LBX 332, LBX 432 Series  
Saddle Legs**

**Not Pictured:**  
Vicon Leg Spacers:  
Part#: 001-6707BS (x2)

Handrail:  
Part#: 001-6707HR (x1)

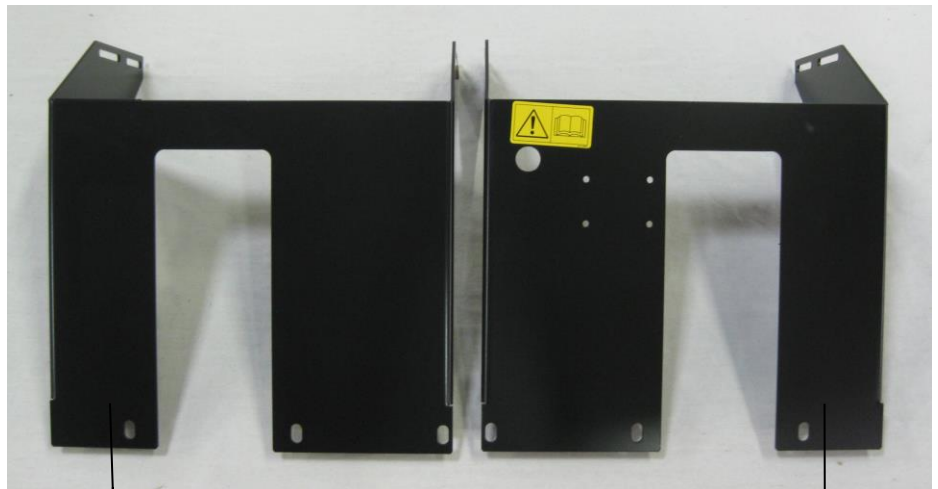

**Left Leg** Part#:001-6707BL  
(2010 and older 4 ft wide)

**Right Leg** Part #:001-6707BR  
(2010 and older 4 ft wide)

## Tank, Saddle and Legs 110 Gallon (continued)

**New Holland BB940A, BB960A,  
Case IH LBX 332, LBX 432 Series  
Saddle Legs**



**Left Leg** Part#: 001-6707DL  
(2011 and newer 4 ft wide)

**Right Leg** Part #: 001-6707DR  
(2011 and newer 4 ft wide)

## **Krone Balers**

Part#: 001-6707KA

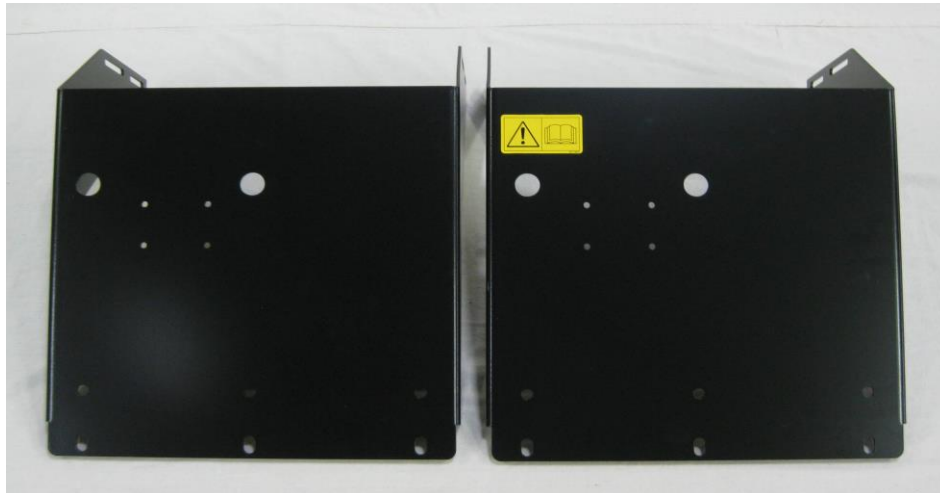

## Parts Breakdown for Pump Manifold

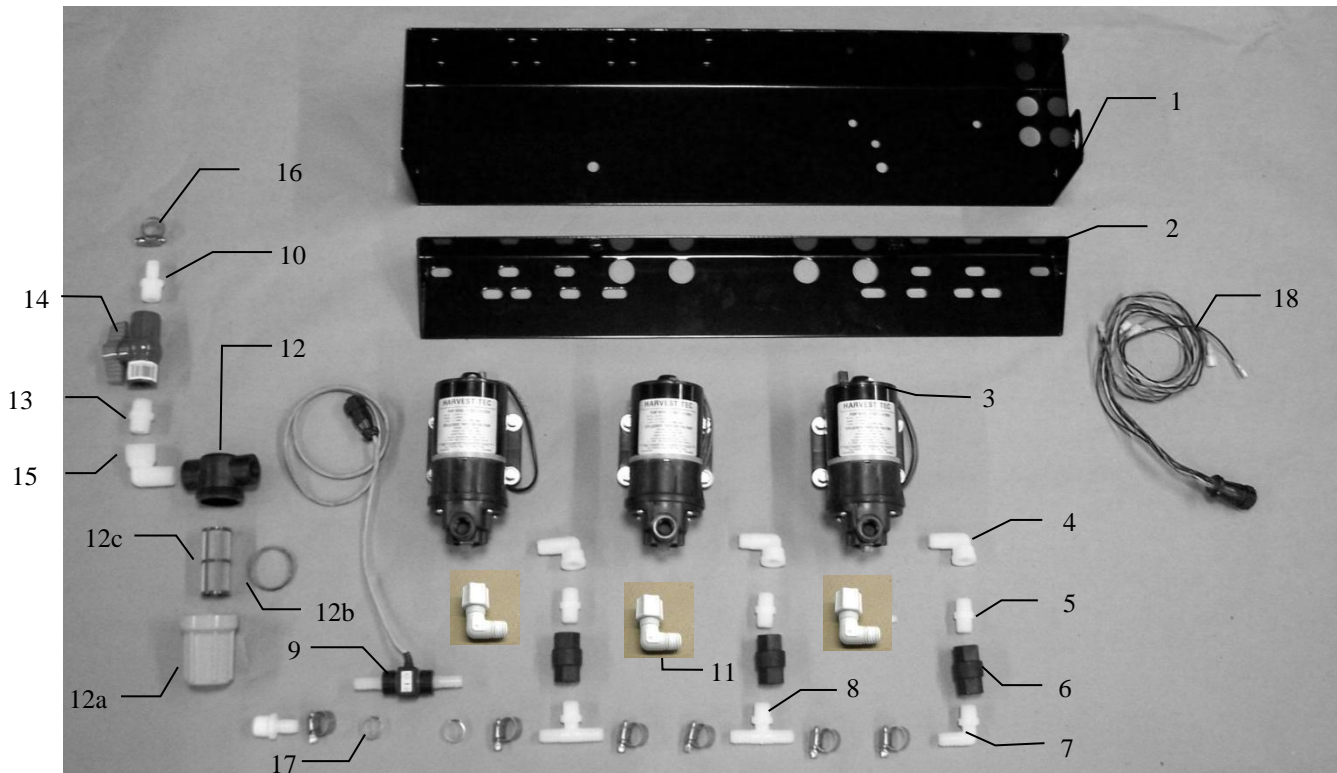

<u>Ref#</u>	<u>Description</u>	<u>Part#</u>	<u>Qty</u>
1	Pump plate	001-4646D	1
2	Mounting Bracket	001-4646C	1
3	Pump	007-4120H	3
4	Street elbow fitting	003-SE38	3
5	Nipple fitting	003-M3838	3
6	Check valve	002-4566F	3
7	Elbow fitting	003-EL3812	1
8	Tee fitting	003-T3812HB	2
9	Flow meter assembly	006-4725A	1
10	Straight fitting	003-A1212	2
11	Jaco fitting	003-JEL1238	3
12	Filter bowl assembly	002-4315-100	1
12a	Filter bowl only	002-4315F	1
12b	Filter bowl gasket	002-4315D	1
12c	Filter bowl screen	002-4315A	1
13	Nipple fitting	003-M1212	1
14	Ball valve	002-2212	1
15	Street elbow fitting	003-SE12	1
16	Hose clamp	003-9003	7
17	Hose clamp (Flow Meter)	003-9005	2
18	Pump Cable	006-4660Z	1
NP	Elbow	003-EL1212	1
NP	Pump rebuild kit (1 per pump)	007-4581	1
NP	Not Pictured		

## Parts Breakdown for Star Wheel Moisture Sensors

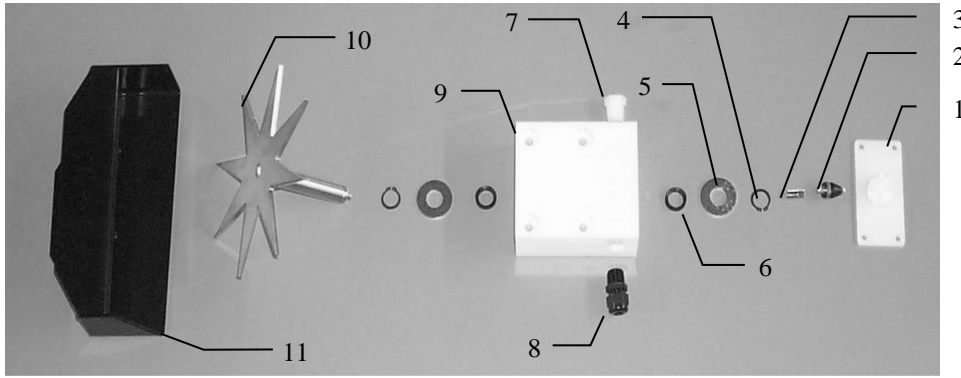

<u>Ref</u>	<u>Description</u>	<u>Part#</u>	<u>Qty</u>	<u>Ref</u>	<u>Description</u>	<u>Part#</u>	<u>Qty</u>
1	Block cover	006-4641B	2	9	Star wheel block	006-4641A	2
2	Electronic swivel	006-4642A	2	10	Star wheel sensor	030-4641C	2
3	Swivel insert	w/ Ref # 10	2	11	Twine guard-left	001-4645	1
4	Snap ring (per side)	006-4641K	2		Twine guard-right (prox)	001-4644	1
5	Washer (per side)	w/006-4641K	2				1
6	Dust seal (per side)	w/006-4641K	2				1
7	Plug fitting	003-F38	2	1-10	Star wheel assembly	030-4641	2
8	Wiring grommet	008-0821A	2				

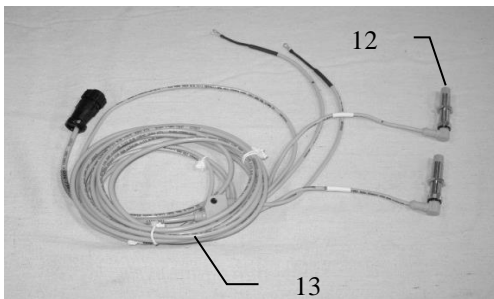

<u>Ref</u>	<u>Description</u>	<u>Part#</u>	<u>Qty</u>
12	Bale rate sensor	006-7303S	2
13	Moisture and bale rate harness	006-7303H	1
	Claas & Krone	006-7303HX	
	Complete Assembly	006-7202	

## Vicon, Kuhn, Krone, Claas 3200-3400

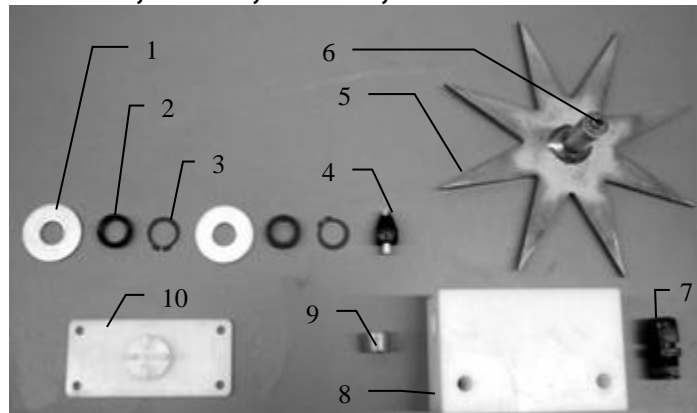

<u>Ref</u>	<u>Description</u>	<u>Part#</u>	<u>Qty</u>	<u>Ref</u>	<u>Description</u>	<u>Part#</u>	<u>Qty</u>
1	Washer (per side)	006-4642K	2	8	Star wheel block	006-4641A	2
2	Dust seal (per side)	w/006-4642K	1	9	Plug fitting	003-F38	2
3	Snap ring (per side)	w/006-4642K	2	10	Block Cover	006-4641B	2
4	Swivel	006-4642A	2	<b>1-10</b>	<b>Star wheel assembly</b>	<b>030-4642</b>	<b>2</b>
5	Star wheel	030-4641E	2	NP	Twine guard – right (prox)	001-4644	1
6	Insert	w/ Ref # 5	2	NP	Twine guard – left	001-4645	1
7	Wiring grommet	008-0821A	2				



## Parts Breakdown for 696 Series Control and Harnesses Dual Channel Processor (DCP)



<u>Ref</u>	<u>Description</u>	<u>Part Number</u>	<u>Qty</u>
1	Pump Controller	006-5672	1
2	End of Bale Sensor	006-7400	1
3a	Hesston 4755, 4910 EOB Mount	001-4648H	1
3b	EOB Bracket CLAAS 3300	001-4648C	1
3c	Krone EOB Bracket	001-4648K2	1
3d	EOB BKT Krone 12130	001-4648K	1
3e	End of Bale Sensor Bracket	001-4648	1
4	DCP Shield Cover	001-5650X	1
5	DCP Main Control LS 600 AUTO	006-6671LS	1
6	Terminating Connector w Green Cap	006-5650Z	1
7	DCP Baler Harness 30 Ft	006-6650LS2	1
8	Modular Power/Comm 10 Ft Harness	006-5650FM	1
9	Optional ISOBUS Tractor Plug (not included)	006-6670A	1
10	DCP Tractor Harness	006-6650TM	1
11	Key Switch Wire	006-5650K	1
12	Dust Plugs	006-5651PLUGS	1
13	Bluetooth Receiver	030-6672A	1

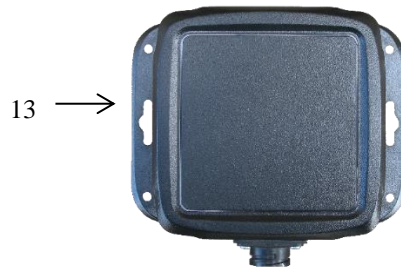

## Parts Breakdown for Hose and Drain Fill Line

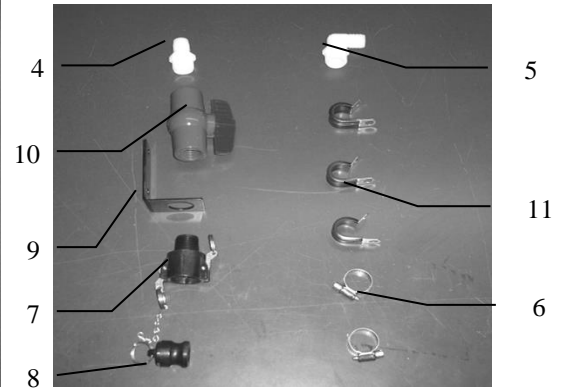
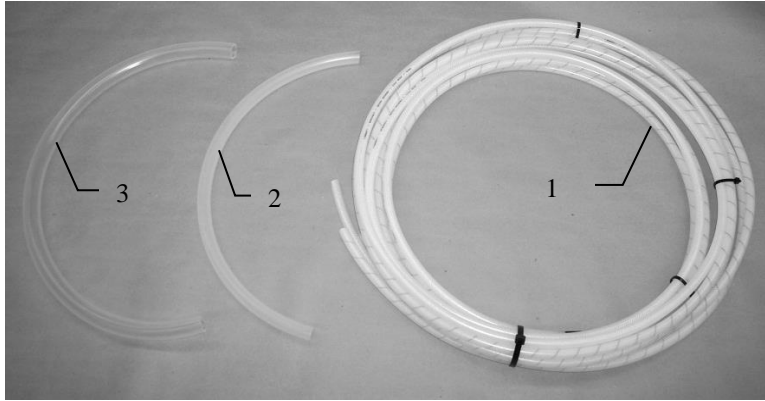

<u>Ref</u>	<u>Description</u>	<u>Part#</u>	<u>Qty</u>	<u>Ref</u>	<u>Description</u>	<u>Part#</u>	<u>Qty</u>
1	Triple weld hose (pumps to tips)	002-9016	35ft	7	Female Coupler	002-2204A	1
		002-9016B	35ft	8	Male Coupler	002-2205G	1
		002-9016G	35ft	9	Valve Holder	001-6702H	1
	Three hose assembly	030-9016LS	1	10	Ball valve	002-2200	1
2	1/2" Hose (tank to filter)	002-9001	6ft	11	Jiffy Clip	008-9010	3
3	3/4" Hose (tank to drain/fill valve)	002-9002	10ft				
4	Straight Fitting	003-A3434	1				
5	Elbow	003-EL3434	1				
6	Hose Clamps	003-9004	2				



## Optional iPad Mini Mounting Kit (030-2012MK)

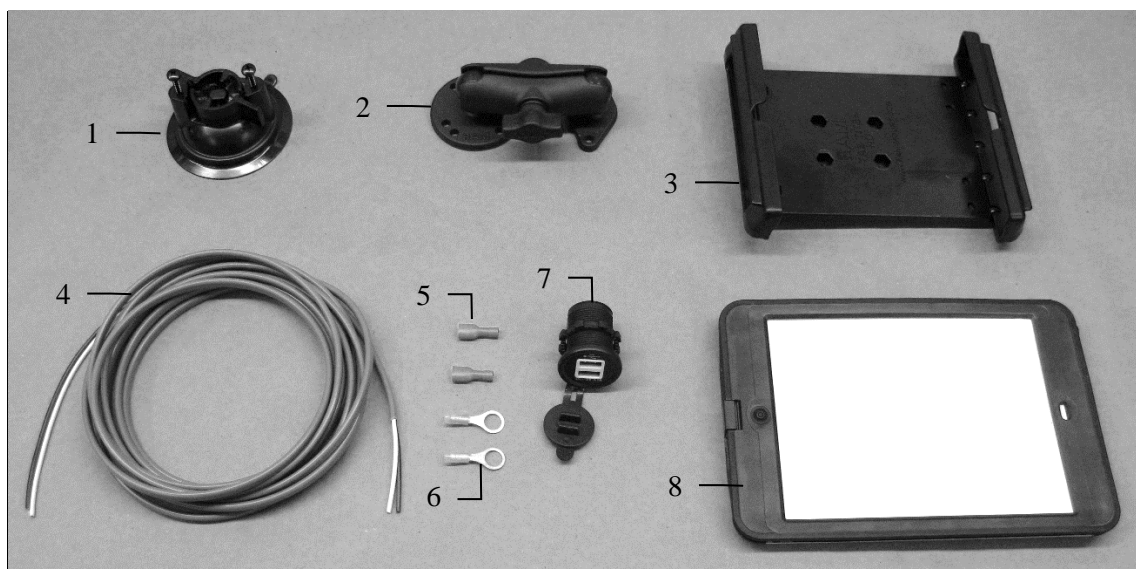

<u>Ref</u>	<u>Description</u>	<u>Part #</u>	<u>Qty</u>
1	Suction cup mount	001-2012SCM	1
2	Ram mount	001-2012H	1
3	iPad Mini spring load cradle (Mini 1,2,3)	001-2012SLC	1
4	16 gauge power wire	006-4723P	1
5	Female spade connector	Hardware	2
6	Eye loop connector	Hardware	2
7	iPad Mini Charger 12V	001-2012P	1
8	iPad Mini 2 case	001-2012C2	1
NP	4 amp fuse	Hardware	1
	Mounting Kit Assembly	030-2012MK (Includes All Parts)	

### Installation Instructions

1. Identify 12V power source for wires to connect.
  - a. Eye loops included if wiring directly to the battery is desired.
  - b. Test for key power source if preferred to have power to the USB shut off with the key.
2. Once power source is identified, cut wires to desired length.
3. Crimp the two supplied quick connectors onto each the white and black wire.
4. Remove the round locking plastic nut from USB plug before connecting the wires. Black (+) White (-).
5. The wires will then be hooked to the designated terminals on the bottom of the USB plug
6. Drill a 1 1/8" hole in the preferred mounting location. Be sure to clean any sharp edges after drilling.
7. Feed the wires through the mounting hole.
8. If using the round plastic nut to secure plug in place, slide the nut back over the wiring before connecting the wires to powered source.
9. Connect the wires to the identified power source if easier to do so before tightening the plug into place.
10. Tighten plug using either the round plastic nut or mounting plate and two screws, both options supplied.
11. Once connected, hook a USB charging cord into the plug and connect a mobile device/tablet to ensure the plug is operating as you wish (key power working properly if necessary).

NOTE: This plug is not designed to charge two iPads. System damage could occur if this is attempted. System will charge a mobile phone and iPad simultaneously without problem.

## Optional iPad Display Kit (030-2670DK)

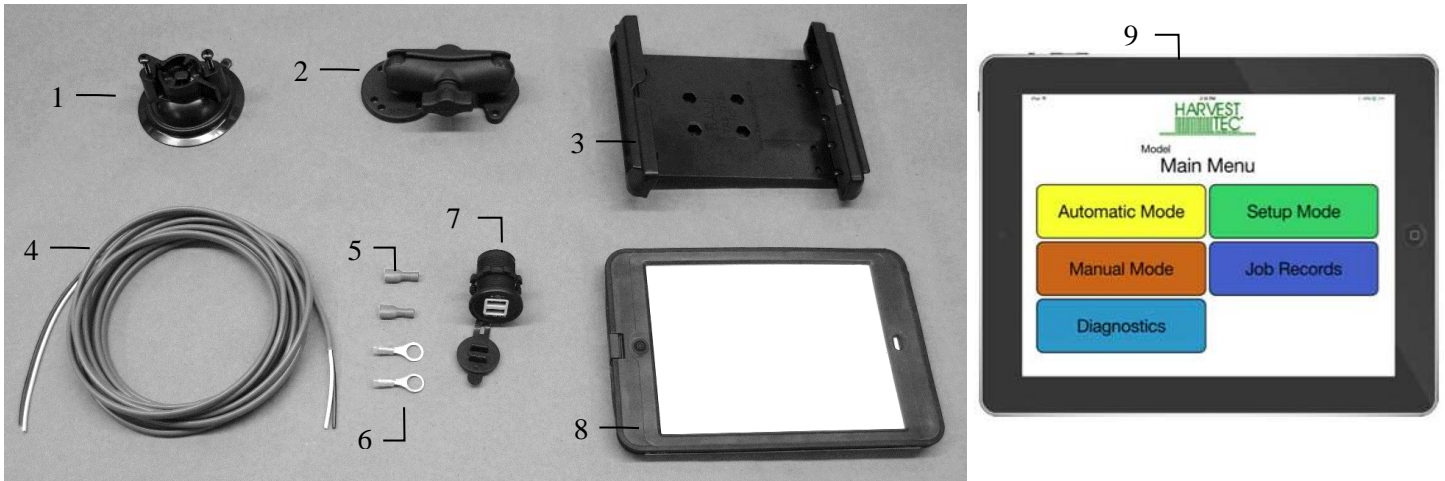

<u>Ref</u>	<u>Description</u>	<u>Part #</u>	<u>Qty</u>	<u>Ref</u>	<u>Description</u>	<u>Part #</u>	<u>Qty</u>
1	Suction cup mount	001-2012SCM	1	7	iPad Mini Charger 12V	001-2012P	1
2	Ram mount	001-2012H	1	8	iPad Mini 2 case	001-2012C2	1
3	iPad Mini spring load cradle (Mini 1,2,3)	001-2012SLC	1	9	iPad Mini 2	006-2670IP	1
4	16 gauge power wire	006-4723P	1	NP	4 amp fuse	Hardware	1
5	Female spade connector	Hardware	2				
6	Eye loop connector	Hardware	2				
					Mounting Kit Assembly	030-2670DK (Includes All Parts)	

### Installation Instructions

12. Identify 12V power source for wires to connect.
  - a. Eye loops included if wiring directly to the battery is desired.
  - b. Test for key power source if preferred to have power to the USB shut off with the key.
13. Once power source is identified, cut wires to desired length.
14. Crimp the two supplied quick connectors onto the white and black wire.
15. Remove the round locking plastic nut from USB plug before connecting the wires. Black (+) White (-).
16. The wires will then be hooked to the designated terminals on the bottom of the USB plug
17. Drill a 1 1/8" hole in the preferred mounting location. Be sure to clean any sharp edges after drilling.
18. Feed the wires through the mounting hole.
19. If using the round plastic nut to secure plug in place, slide the nut back over the wiring before connecting the wires to powered source.
20. Connect the wires to the identified power source if easier to do so before tightening the plug into place.
21. Tighten plug using either the round plastic nut or mounting plate and two screws, both options supplied.
22. Once connected, hook a USB charging cord into the plug and connect a mobile device/tablet to ensure the plug is operating as you wish (key power working properly if necessary).

NOTE: This plug is not designed to charge two iPads. System damage could occur if this is attempted. System will charge a mobile phone and iPad simultaneously without problem.

## 4438B Installation Kit

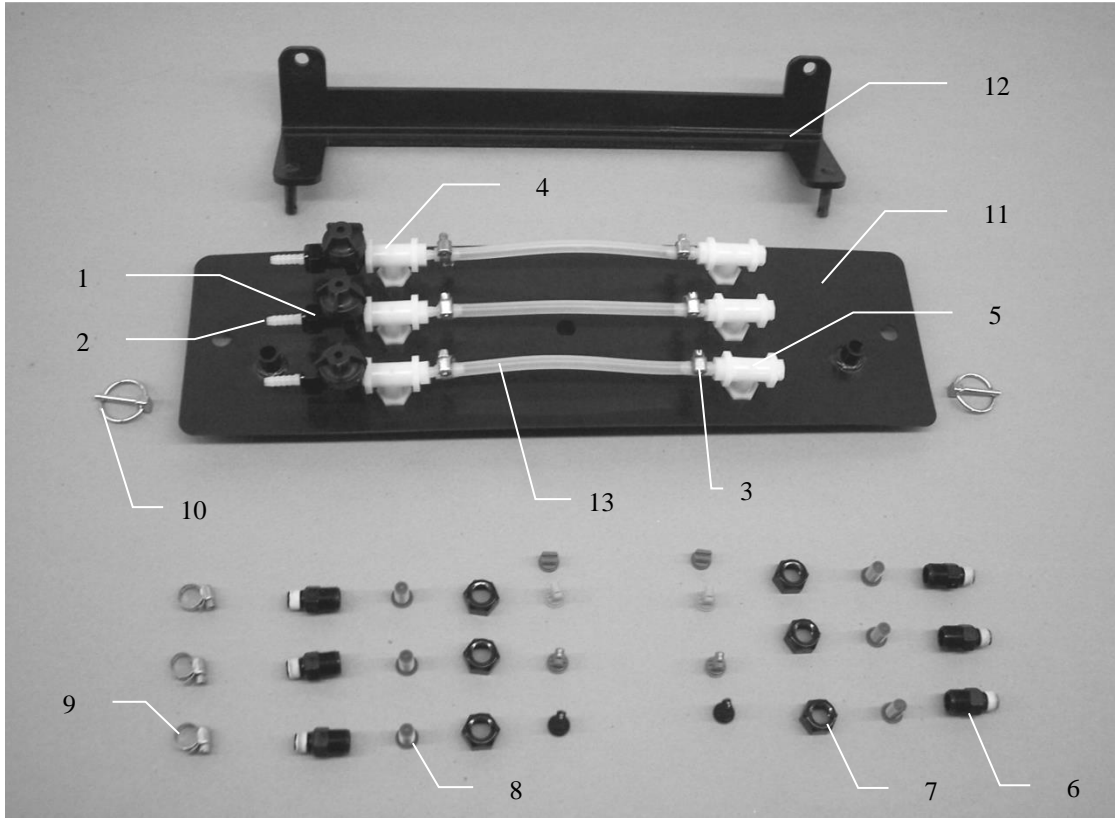

<u>Ref</u>	<u>Description</u>	<u>Part #</u>	<u>Qty</u>	<u>Description</u>	<u>Part #</u>	<u>Qty</u>
1	Check valve	004-1207VB	3	Tip (olive green)	004-800067-PT	2
2	Straight fitting	003-A1414VB	3	Tip (orange)	004-TT11001VP	2
3	Straight fitting	003-A1414	6	Tip (green)	004-TT110015VP	2
4	Tee	003-TT14SQ	3	Tip (blue)	004-TT11003VP	2
5	Street elbow	003-SE14F	3			
6	Nozzle body	004-4722	6			
7	Nozzle cap	004-4723	9			
8	Tip strainer	004-1203-100	6			
9	Hose clamp	003-9002	9			
10	Lynch pin	008-4576	2			
11	Spray shield	001-4438A	1			
12	Mounting bracket	001-4438B	1			
13	Hose – 1/4"	002-9016	3ft			

## 4439B Installation Kit

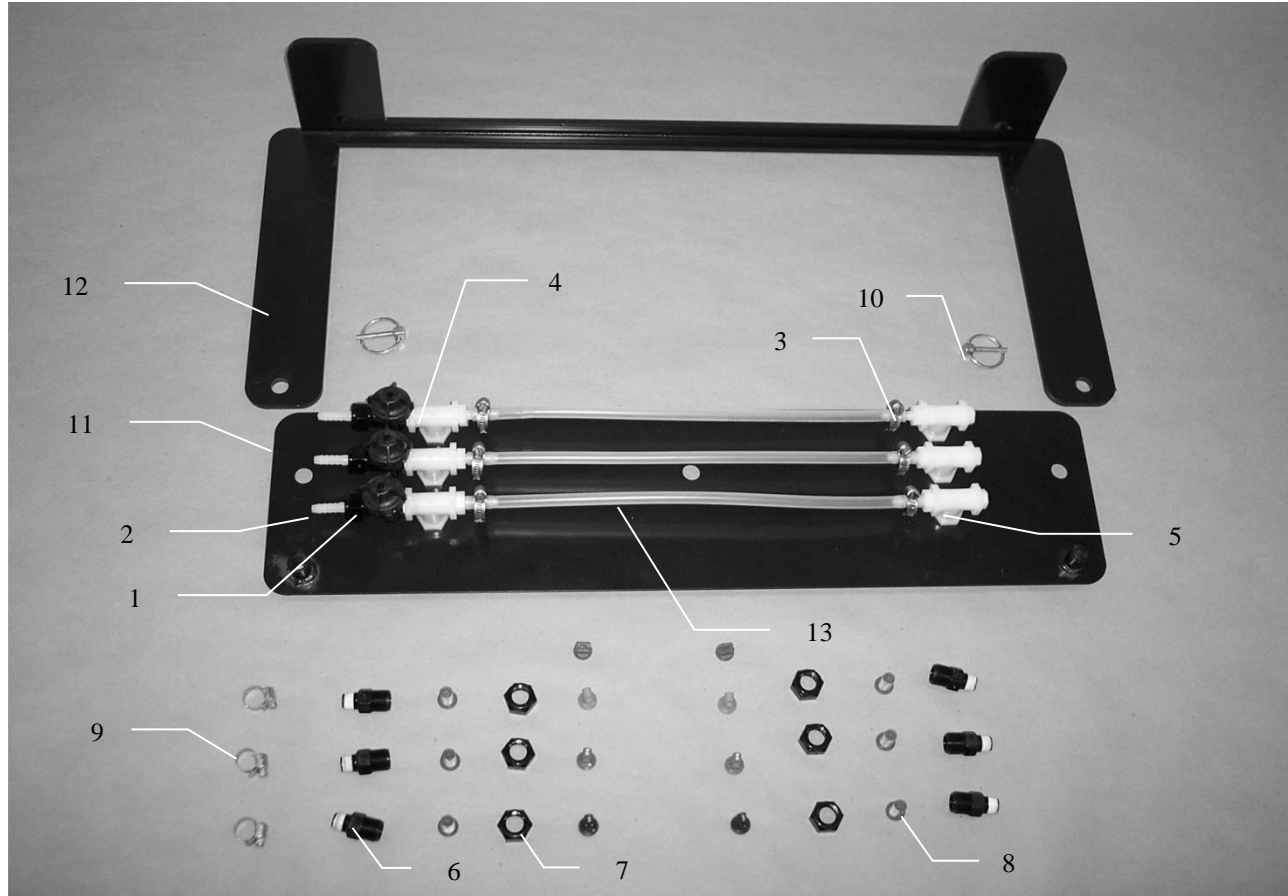

<u>Ref</u>	<u>Description</u>	<u>Part #</u>	<u>Qty</u>	<u>Description</u>	<u>Part #</u>	<u>Qty</u>
1	Check valve	004-1207VB	3	Tip (olive green)	004-800067-PT	2
2	Straight fitting	003-A1414VB	3	Tip (orange)	004-TT11001VP	2
3	Straight fitting	003-A1414	6	Tip (green)	004-TT110015VP	2
4	Tee	003-TT14SQ	3	Tip (blue)	004-TT11003VP	2
5	Street elbow	003-SE14F	3			
6	Nozzle body	004-4722	6			
7	Nozzle cap	004-4723	9			
8	Tip strainer	004-1203-100	6			
9	Hose clamp	003-9002	9			
10	Lynch pin	008-4576	2			
11	Spray shield	001-4439A	1			
12	Mounting bracket	001-4439B	1			
13	Hose – 1/4"	002-9016	3			

## 4490B Installation Kit

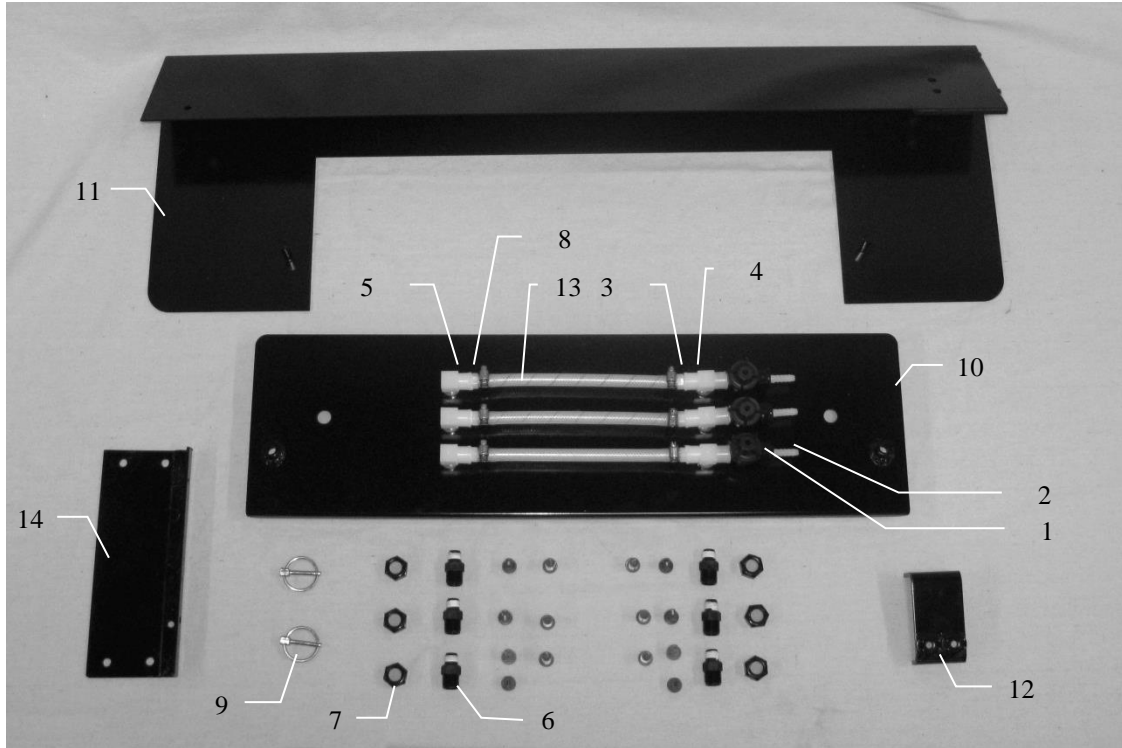

<u>Ref</u>	<u>Description</u>	<u>Part #</u>	<u>Qty</u>	<u>Description</u>	<u>Part #</u>	<u>Qty</u>
1	Check valve	004-1207VB	3	Tip (olive green)	004-800067-PT	2
2	Straight fitting	003-A1414VB	3	Tip (orange)	004-TT11001VP	2
3	Straight fitting	003-A1414	6	Tip (green)	004-TT110015VP	2
4	Tee	003-TT14SQ	3	Tip (blue)	004-TT11003VP	2
5	Street elbow	003-SE14F	3	Tip strainer	004-1203-100	6
6	Nozzle body	004-4722	6			
7	Nozzle cap	004-4723	9			
8	Hose clamp	003-9002	9			
9	Lynch pin	008-4576	2			
10	Spray shield	001-4421	1			
11	Shield holder	001-4421B	1			
12	Backing plate	001-4421A	1			
13	Hose – 1/4"	002-9016	3ft			
14	End of bale mount	001-4648H	1			

## 4491B Installation Kit

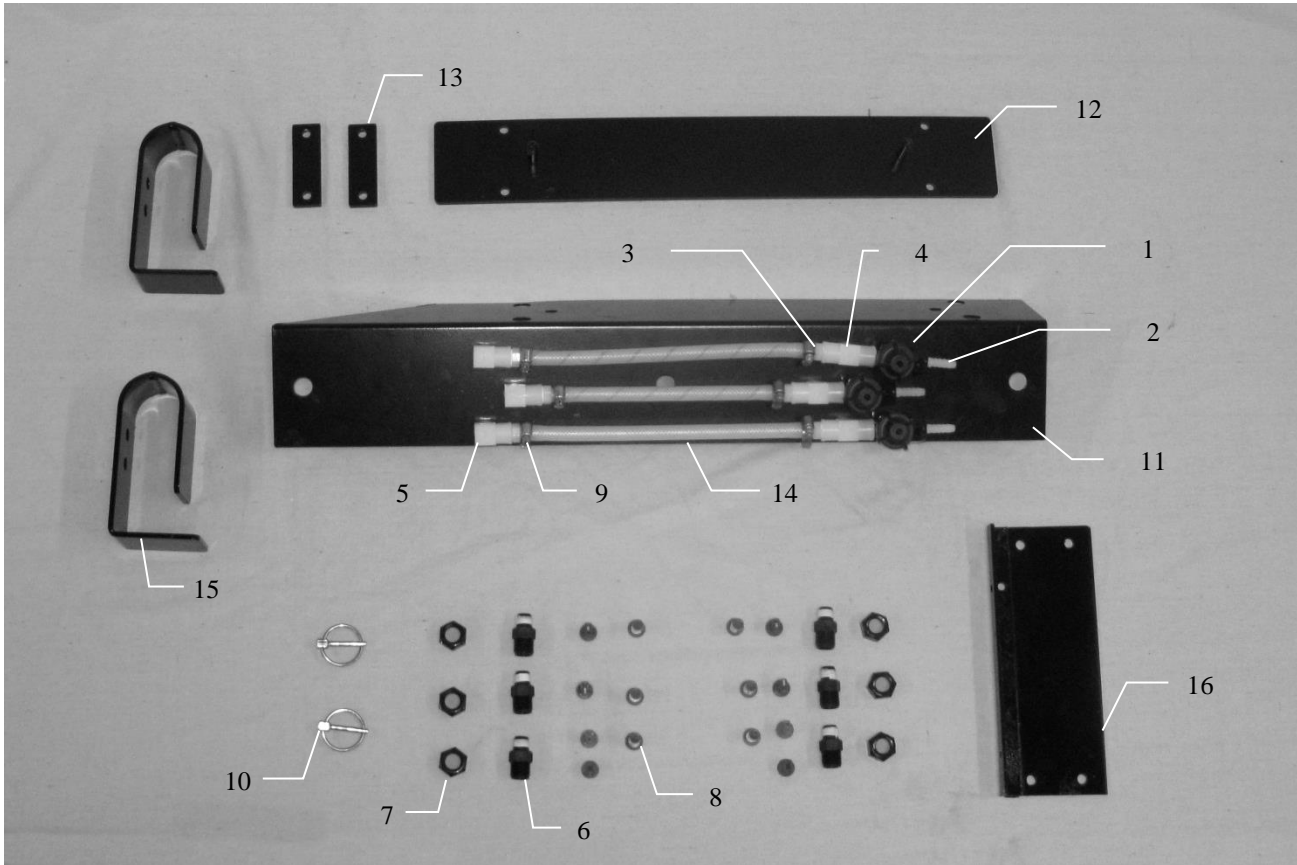

<u>Ref</u>	<u>Description</u>	<u>Part #</u>	<u>Qty</u>	<u>Description</u>	<u>Part #</u>	<u>Qty</u>
1	Check valve	004-1207VB	3	Tip (olive green)	004-800067-PT	2
2	Straight fitting	003-A1414VB	3	Tip (orange)	004-TT11001VP	2
3	Straight fitting	003-A1414	6	Tip (green)	004-TT110015VP	2
4	Tee	003-TT14SQ	3	Tip (blue)	004-TT11003VP	2
5	Street elbow	003-SE14F	3			
6	Nozzle body	004-4722	6			
7	Nozzle cap	004-4723	9			
8	Tip strainer	004-1203-100	6			
9	Hose clamp	003-9002	9			
10	Lynch pin	008-4576	2			
11	Spray shield	001-4422	1			
12	Shield holder	001-4422B	1			
13	Backing plate	001-4422A	2			
14	Hose – 1/4"	002-9016	3ft			
15	Ladder bracket	001-6707H	2			
16	End of bale mount	001-4648H	1			



## 4492B Installation Kit

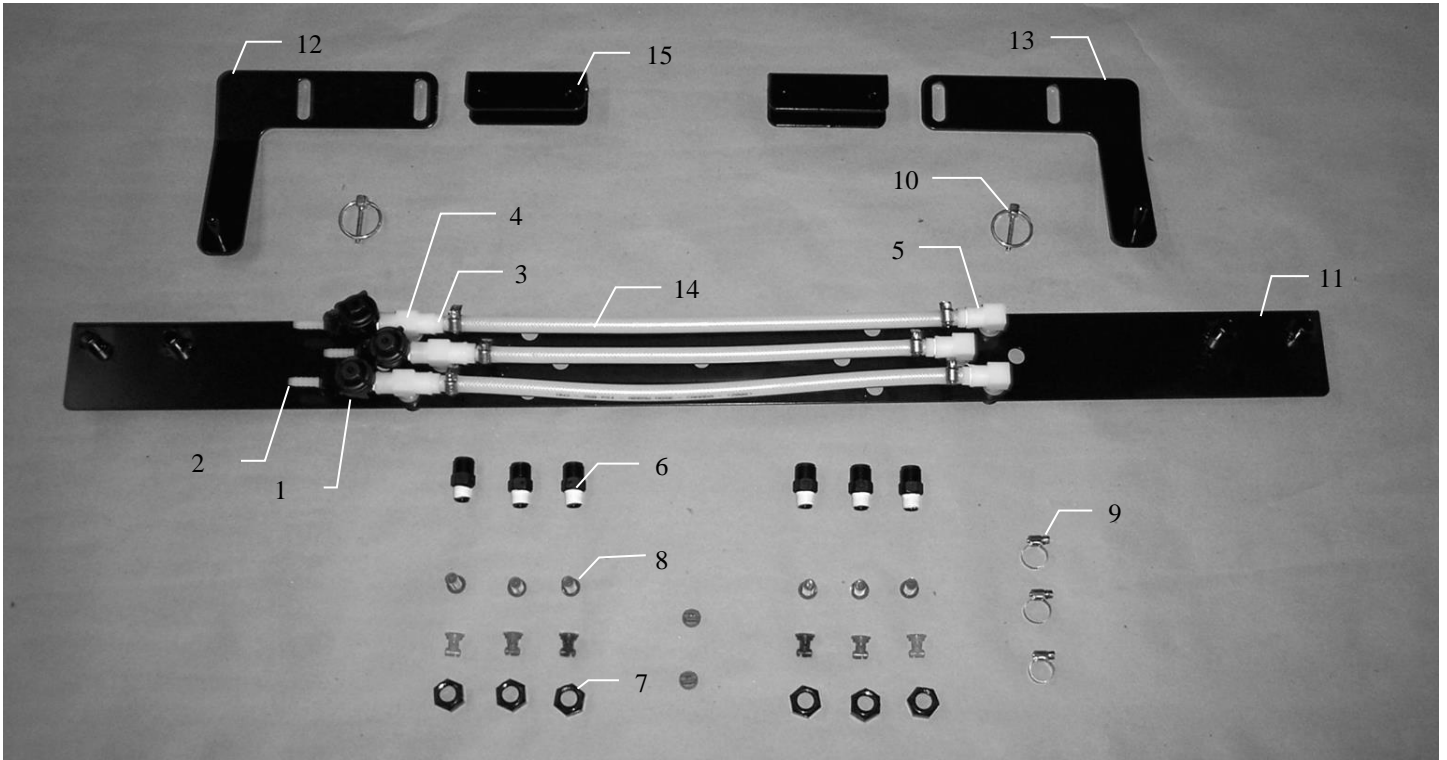

<u>Ref</u>	<u>Description</u>	<u>Part #</u>	<u>Qty</u>	<u>Description</u>	<u>Part #</u>	<u>Qty</u>
1	Check valve	004-1207VB	3	Tip (olive green)	004-800067-PT	2
2	Straight fitting	003-A1414VB	3	Tip (orange)	004-TT11001VP	2
3	Straight fitting	003-A1414	6	Tip (green)	004-TT110015VP	2
4	Tee	003-TT14SQ	3	Tip (blue)	004-TT11003VP	2
5	Street elbow	003-SE14F	3			
6	Nozzle body	004-4722	6			
7	Nozzle cap	004-4723	9			
8	Tip strainer	004-1203-100	6			
9	Hose clamp	003-9002	9			
10	Lynch pin	008-4576	2			
11	Spray shield	001-4811A	1			
12	Left shield holder	001-4436DL	1			
13	Right shield holder	001-4436DR	1			
14	Hose – 1/4"	002-9016	3ft			
15	Spacer	001-4436S	2			

## 4494B Installation Kit

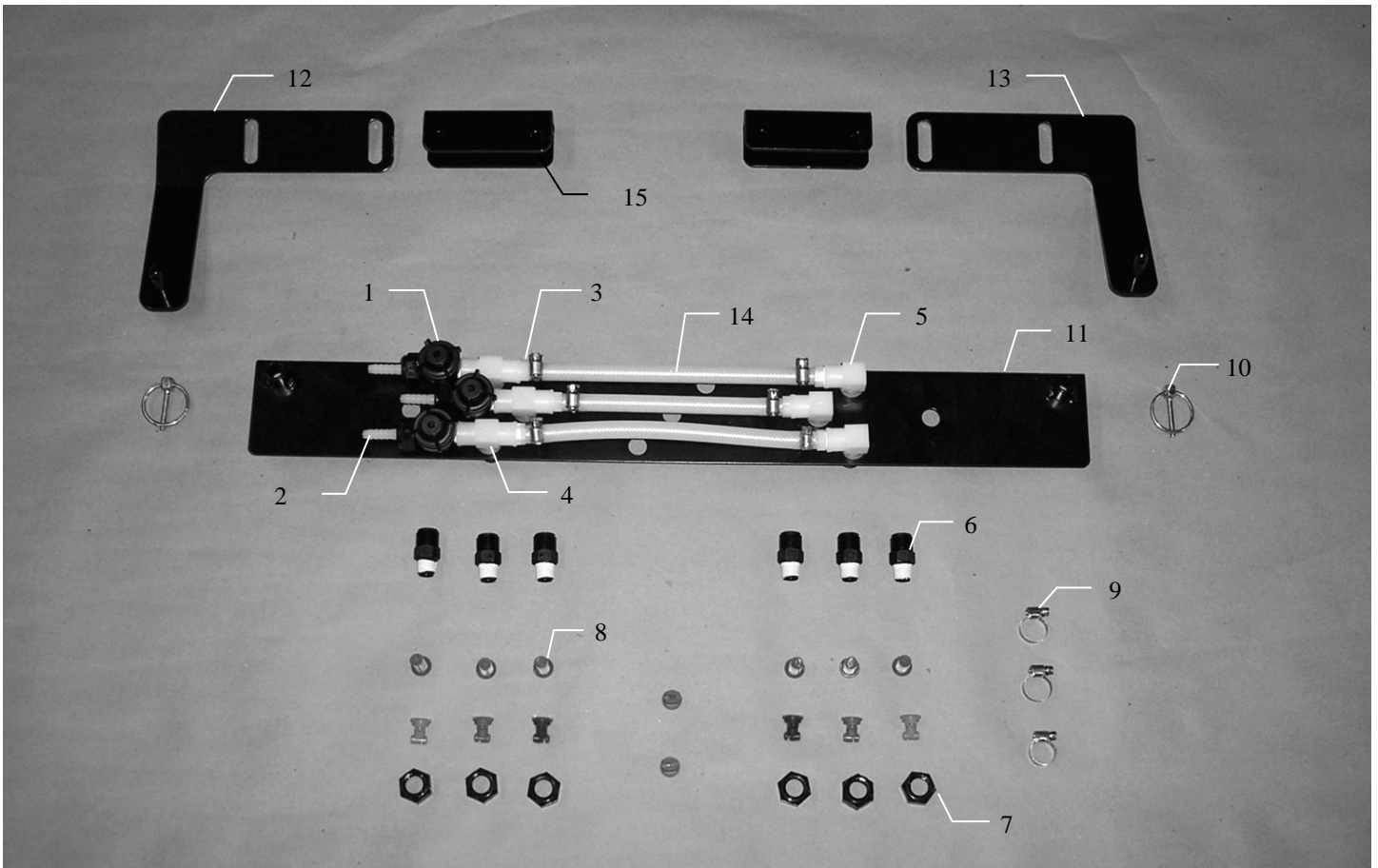

<u>Ref</u>	<u>Description</u>	<u>Part #</u>	<u>Qty</u>	<u>Description</u>	<u>Part #</u>	<u>Qty</u>
1	Check valve	004-1207VB	3	Tip (olive green)	004-800067-PT	2
2	Straight fitting	003-A1414VB	3	Tip (orange)	004-TT11001VP	2
3	Straight fitting	003-A1414	6	Tip (green)	004-TT110015VP	2
4	Tee	003-TT14SQ	3	Tip (blue)	004-TT11003VP	2
5	Street elbow	003-SE14F	3			
6	Nozzle body	004-4722	6			
7	Nozzle cap	004-4723	9			
8	Tip strainer	004-1203-100	6			
9	Hose clamp	003-9002	9			
10	Lynch pin	008-4576	2			
11	Spray shield	001-4810	1			
12	Left shield holder	001-4436DL	1			
13	Right shield holder	001-4436DR	1			
14	Hose – 1/4"	002-9016	3ft			
15	Spacer	001-4436S	2			

## 4495B & 4528B Installation Kit

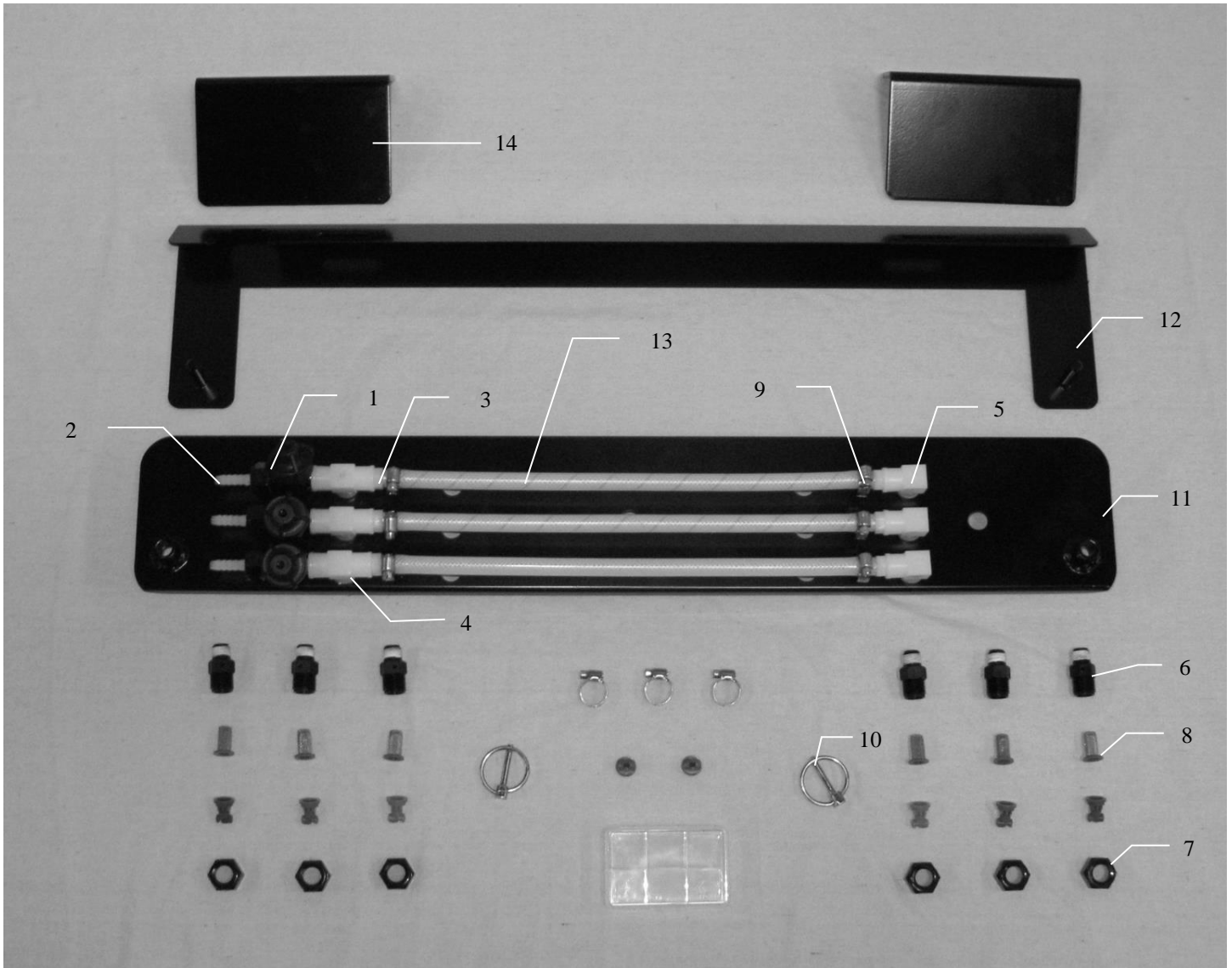

<u>Ref</u>	<u>Description</u>	<u>Part#</u>	<u>Qty</u>	<u>Description</u>	<u>Part#</u>	<u>Qty</u>
1	Check valve	004-1207VB	3	Tip (olive green)	004-800067-PT	2
2	Straight fitting	003-A1414VB	3	Tip (orange)	004-TT11001VP	2
3	Straight fitting	003-A1414	6	Tip (green)	004-TT110015VP	2
4	Tee	003-TT14SQ	3	Tip (blue)	004-TT11003VP	2
5	Street elbow	003-SE14F	3			
6	Nozzle body	004-4722	6			
7	Nozzle cap	004-4723	9			
8	Tip strainer	004-1203-100	6			
9	Hose clamp	003-9002	9			
10	Lynch pin	008-4576	2			
11	Spray shield	001-4431	1			
12	Shield holder	001-4431B	1			
13	Hose – 1/4"	002-9016	3ft			
14	Wind guard stop	001-4431D	2			

## 4497B & 4529B Installation Kit

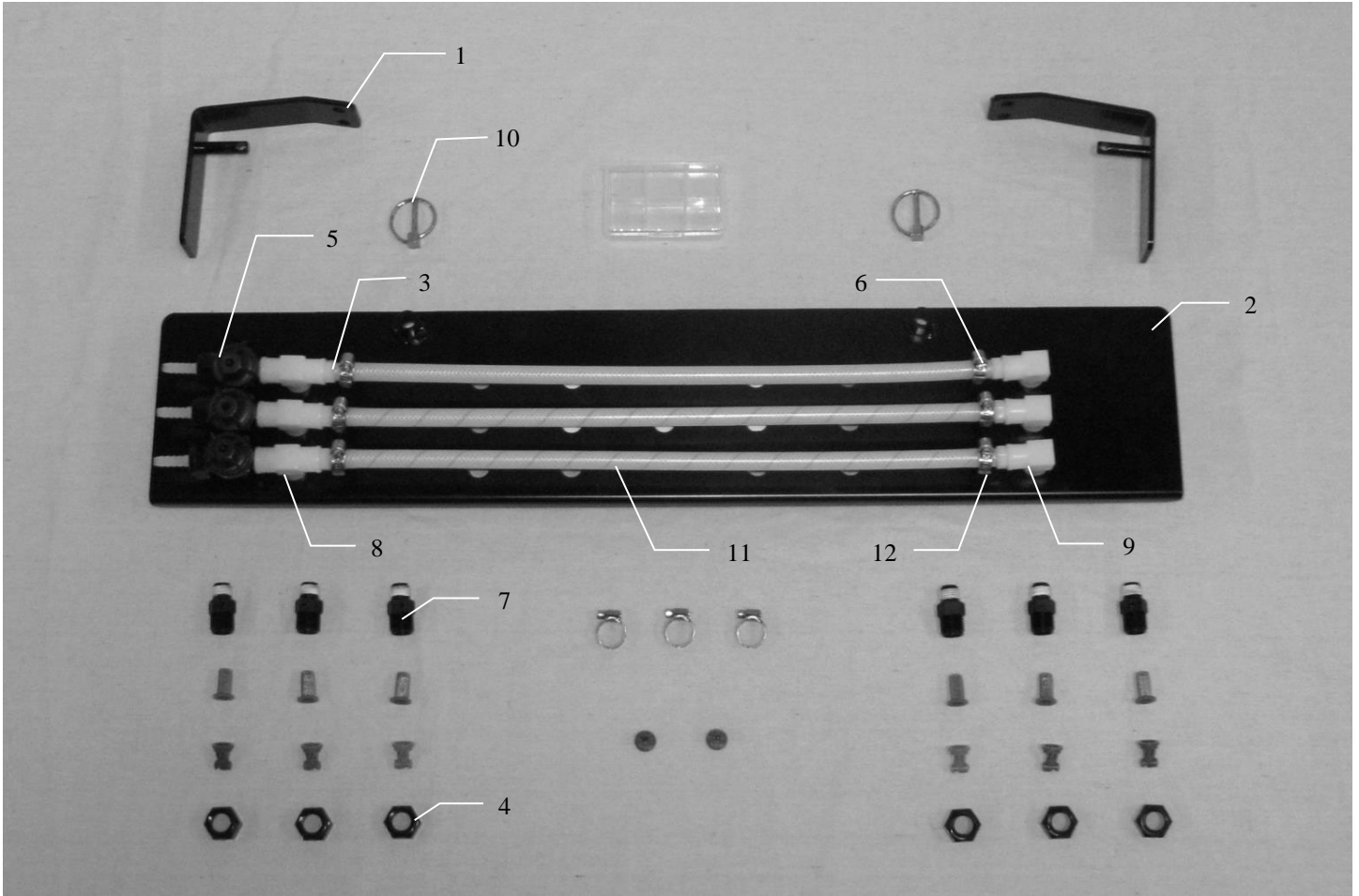

<u>Ref</u>	<u>Description</u>	<u>Part#</u>	<u>Qty</u>	<u>Description</u>	<u>Part#</u>	<u>Qty</u>
1	Mounting Brkt	001-4435E	2	Tip (orange)	004-TT11001VP	2
2	Spray Shield	001-4435ES	1	Tip (green)	004-TT110015VP	2
3	Straight Fitting	003-A1414VB	3	Tip (blue)	004-TT11003VP	2
4	Nozzle Cap	004-4723	9	Tip (olive green)	004-800067-PT	2
5	Check Valve	004-1207VB	3	Tip Strainers	004-1203-100	6
6	Straight Fitting	003-A1414	6			
7	Nozzle Body	004-4722	6			
8	Tee	003-TT14SQ	3			
9	Street elbow	003-SE14F	3			
10	Lynch Pin	008-4576	2			
11	Hose	002-9016	4ft			
12	Hose Clamps	003-9002	9			

## 4498B Installation Kit

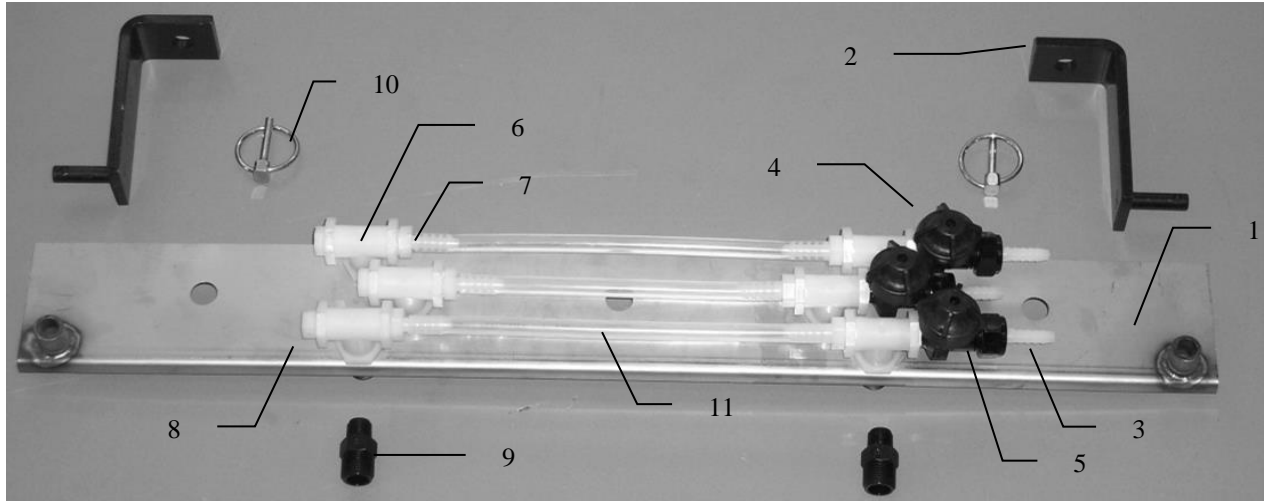

<u>Ref</u>	<u>Description</u>	<u>Part#</u>	<u>Qty</u>	<u>Ref</u>	<u>Description</u>	<u>Part#</u>	<u>Qty</u>
1	Spray Shield	001-4810	1	NP	Tip (orange)	004-TT11001VP	2
2	Shield Holder	001-4810A	2	NP	Tip (green)	004-TT110015VP	2
3	Straight Fitting	003-A1414VB	3	NP	Tip (blue)	004-TT11003VP	2
4	Check Valve	004-1207VB	3	NP	Tip (olive green)	004-800067-PT	2
5	Nozzle Cap	004-4723	9	NP	Tip Strainers	004-1203-100	6
6	Tee	003-TT14	6	NP	Hose Clamps	003-9002	9
7	Straight Fitting	003-A1414	6				
8	Plug	003-F14	3	NP	Not Pictured		
9	Nozzle Body	004-4722	6				
10	Lynch Pin	008-4576	2				
11	Hose	002-9006	4ft				

## 4499B Installation Kit

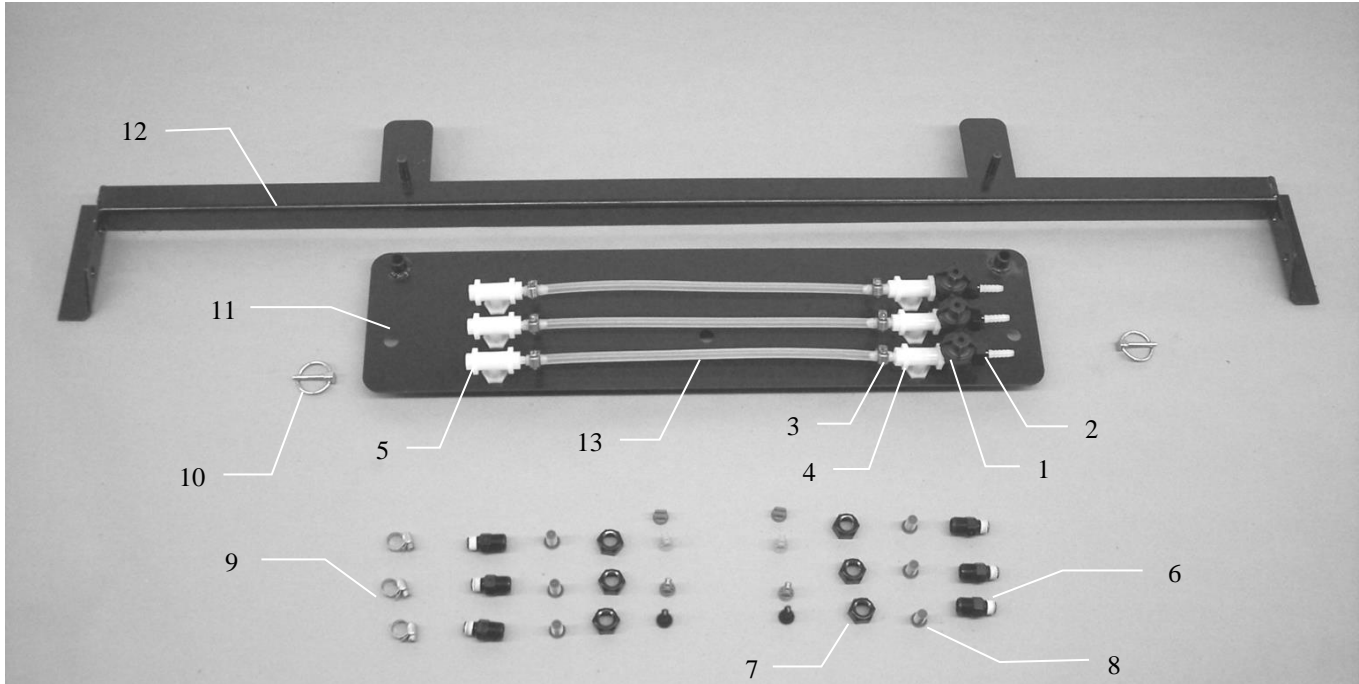

<u>Ref</u>	<u>Description</u>	<u>Part#</u>	<u>Qty</u>	<u>Description</u>	<u>Part#</u>	<u>Qty</u>
1	Check valve	004-1207VB	3	Tip (olive green)	004-800067-PT	2
2	Straight fitting	003-A1414VB	3	Tip (orange)	004-TT11001VP	2
3	Straight fitting	003-A1414	6	Tip (green)	004-TT110015VP	2
4	Tee	003-TT14SQ	3	Tip (blue)	004-TT11003VP	2
5	Street elbow	003-SE14F	3			
6	Nozzle body	004-4722	6			
7	Nozzle cap	004-4723	9			
8	Tip strainer	004-1203-100	6			
9	Hose clamp	003-9002	9			
10	Lynch pin	008-4576	2			
11	Spray shield	001-4439A	1			
12	Shield holder	001-4440	1			
13	Hose – 1/4"	002-9016	3ft			



## 4500B Installation Kit

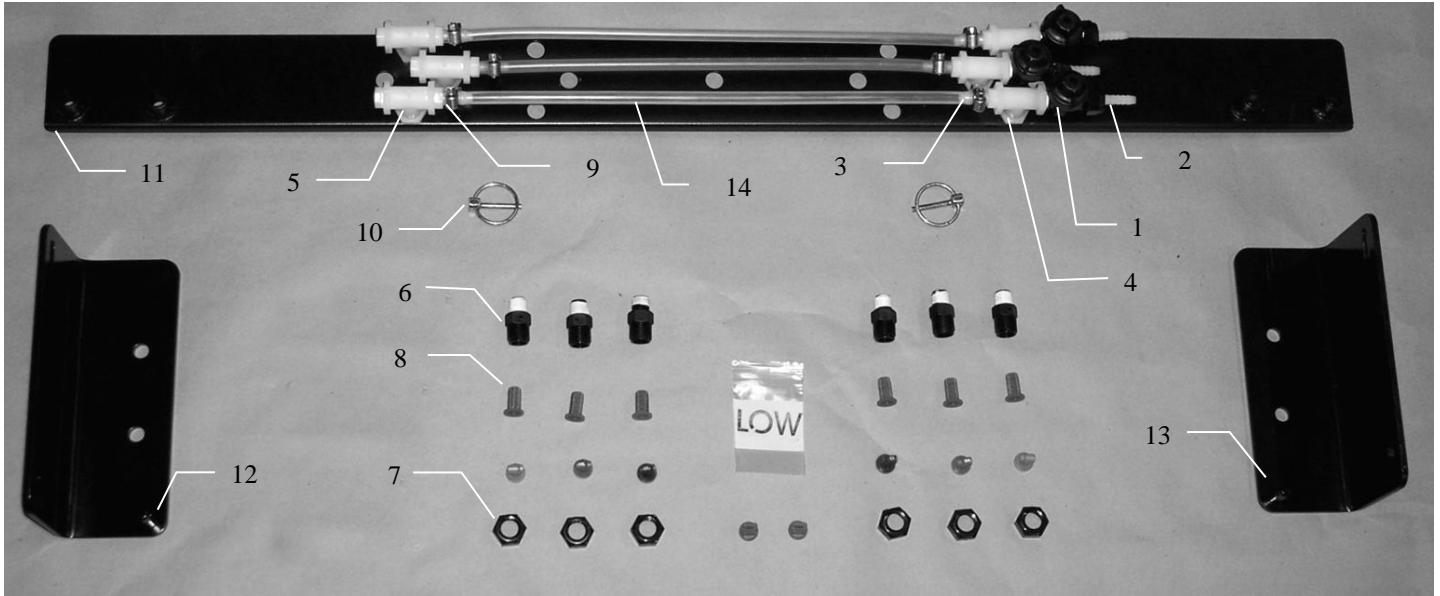

<u>Ref</u>	<u>Description</u>	<u>Part#</u>	<u>Qty</u>	<u>Description</u>	<u>Part#</u>	<u>Qty</u>
1	Check valve	004-1207VB	3	Tip (olive green)	004-800067-PT	2
2	Straight fitting	003-A1414VB	3	Tip (orange)	004-TT11001VP	2
3	Straight fitting	003-A1414	6	Tip (green)	004-TT110015VP	2
4	Tee	003-TT14SQ	3	Tip (blue)	004-TT11003VP	2
5	Street elbow	003-SE14F	3			
6	Nozzle body	004-4722	6			
7	Nozzle cap	004-4723	9			
8	Tip strainer	004-1203-100	6			
9	Hose clamp	003-9002	9			
10	Lynch pin	008-4576	2			
11	Spray shield	001-4811A	1			
12	Left shield holder	001-4436CL	1			
13	Right shield holder	001-4436CR	1			
14	Hose	002-9016	3ft			

## 4501B Installation Kit

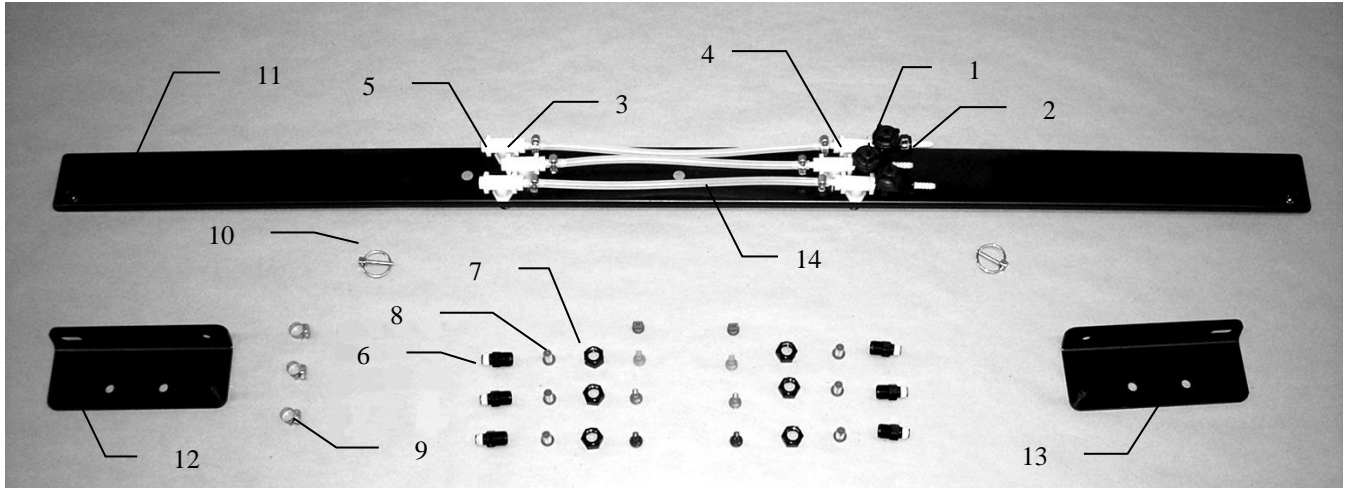

<u>Ref</u>	<u>Description</u>	<u>Part#</u>	<u>Qty</u>	<u>Description</u>	<u>Part#</u>	<u>Qty</u>
1	Check valve	004-1207VB	3	Tip (olive green)	004-800067-PT	2
2	Straight fitting	003-A1414VB	3	Tip (orange)	004-TT11001VP	2
3	Straight fitting	003-A1414	6	Tip (green)	004-TT110015VP	2
4	Tee	003-TT14SQ	3	Tip (blue)	004-TT11003VP	2
5	Street elbow	003-SE14F	3			
6	Nozzle body	004-4722	6			
7	Nozzle cap	004-4723	9			
8	Tip strainer	004-1203-100	6			
9	Hose clamp	003-9002	9			
10	Lynch pin	008-4576	2			
11	Spray shield	001-4436CS	1			
12	Left shield holder	001-4436CL	1			
13	Right shield holder	001-4436CR	1			
14	Hose – 1/4"	002-9016	3ft			

## 4509B Installation Kit

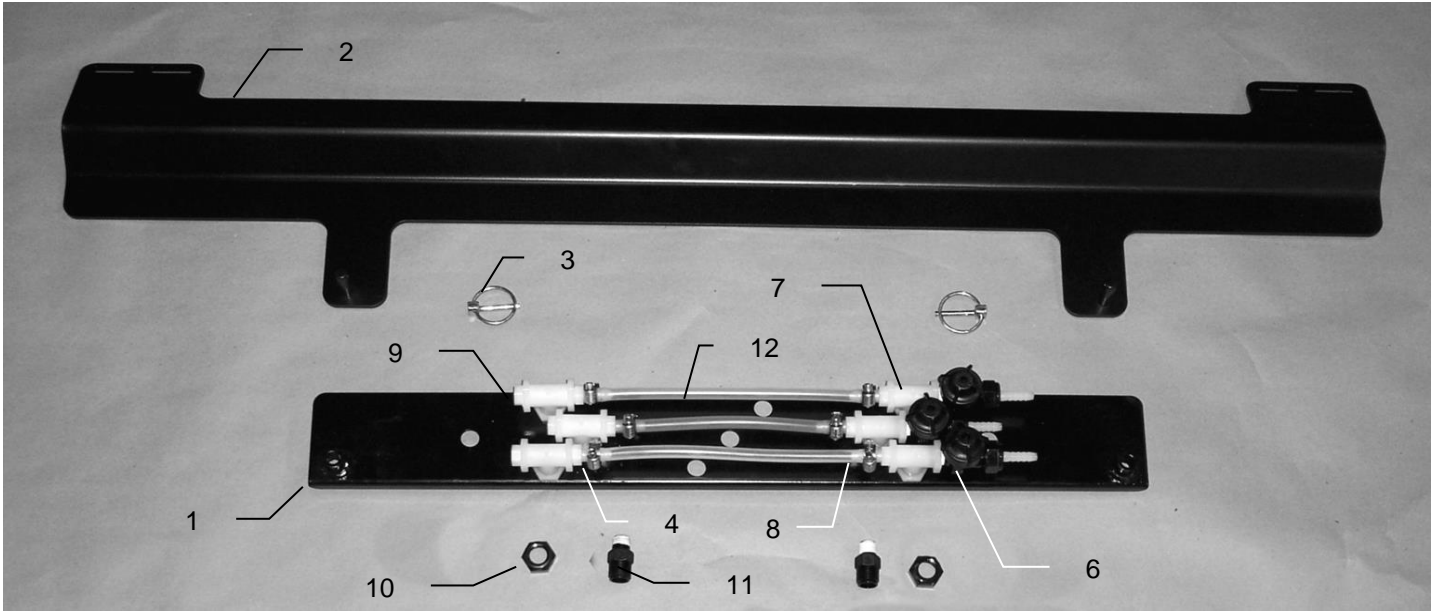

<u>Ref</u>	<u>Description</u>	<u>Part #</u>	<u>Qty</u>	<u>Description</u>	<u>Part #</u>	<u>Qty</u>
1	Spray Shield	001-4810	1	Tip (blue)	004-TT11001VP	2
2	Shield holder	001-4440A	1	Tip (green)	004-TT110015VP	2
3	Lynch Pins	008-4576	2	Tip (orange)	004-TT11003VP	2
4	Hose Clamps	003-9002	9	Tip (olive green)	004-800067-PT	2
5	Straight Fitting	003-A1414VB	3	Tip Strainers	004-1203-100	6
6	Check Valve	004-1207VB	3			
7	Tee	003-TT14SQ	3			
8	Straight Fitting	003-A1414	6			
9	90 degree elbow	003-SE14F	3			
10	Nozzle Cap	004-4723	9			
11	Nozzle Body	004-4722	6			
12	Hose	002-9016	3ft			

## 4510B Installation Kit

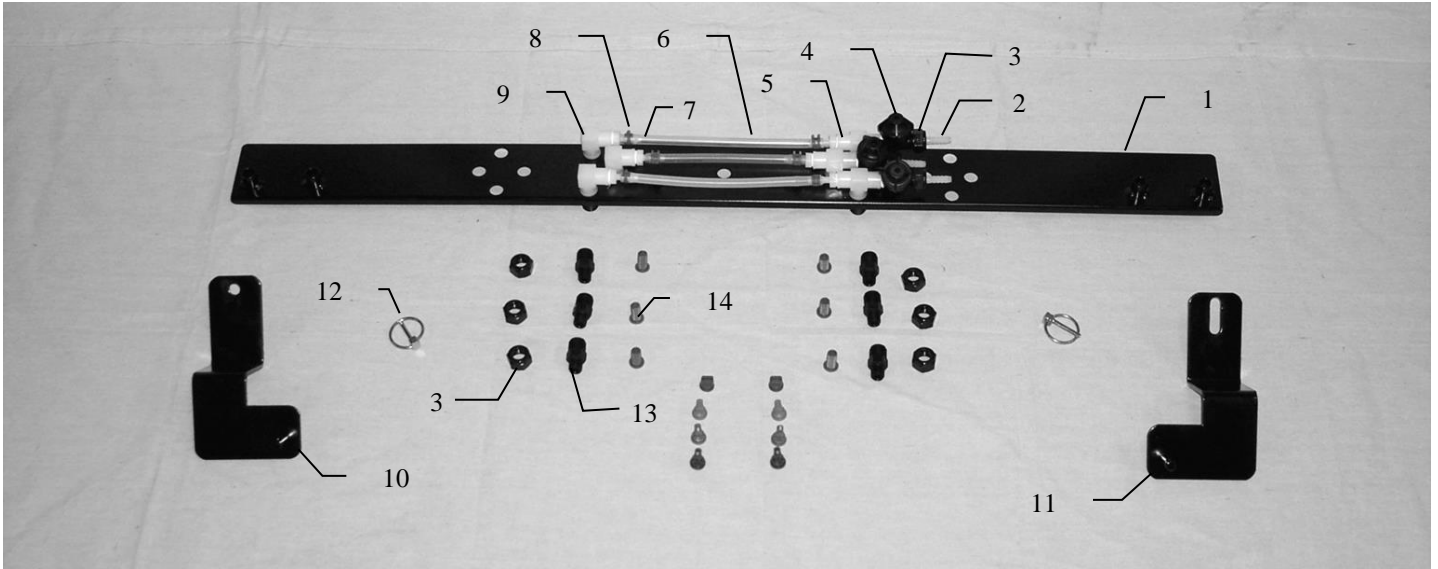

<u>Ref</u>	<u>Description</u>	<u>Part #</u>	<u>Qty</u>	<u>Description</u>	<u>Part #</u>	<u>Qty</u>
1	Spray shield	001-4811A	1	Tip (orange)	004-TT11001VP	2
2	Straight fitting	003-A1414VB	3	Tip (green)	004-TT110015VP	2
3	Nozzle cap	004-4723	9	Tip (blue)	004-TT11003VP	2
4	Check valve	003-1207VB	3	Tip (olive green)	004-800067-PT	2
5	Tee	003-TT14SQ	3			
6	Hose	002-9016	3ft			
7	Straight fitting	003-A1414	6			
8	Hose clamp	003-9002	9			
9	Elbow	003-SE14F	3			
10	Shield hanger	001-4704A	1			
11	Shield hanger	001-4704B	1			
12	Lynch pin	008-4576	2			
13	Nozzle body	004-4722	6			
14	Tip Strainers	004-1203-100	6			

## 4511B Installation Kit

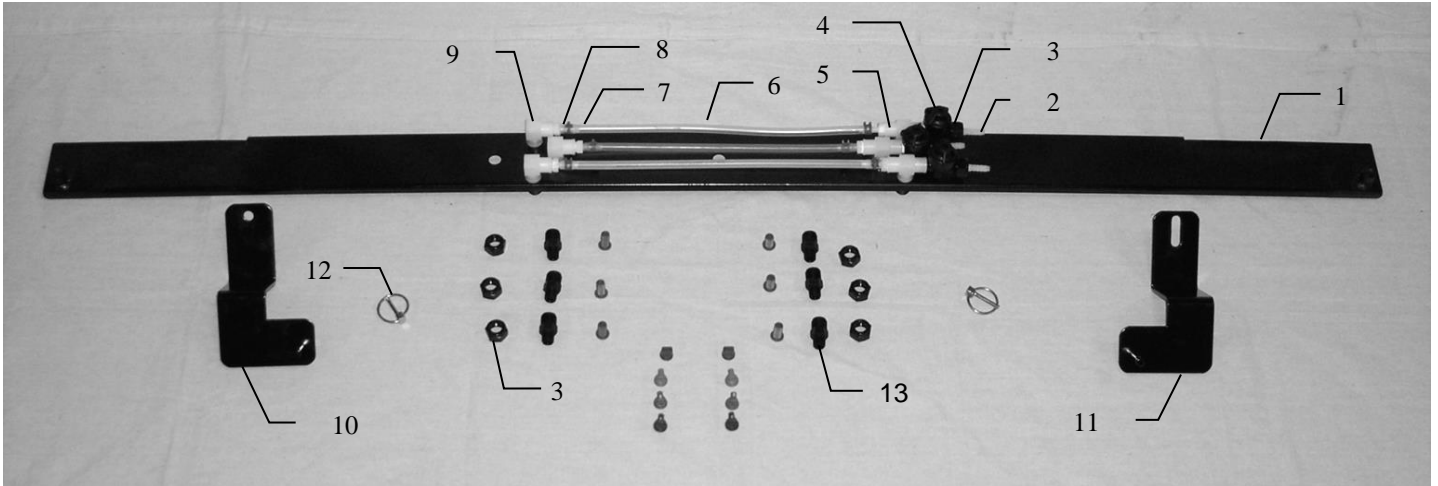

<u>Ref</u>	<u>Description</u>	<u>Part #</u>	<u>Qty</u>	<u>Description</u>	<u>Part #</u>	<u>Qty</u>
1	Spray shield	001-4704C	1	Tip (orange)	004-TT11001VP	2
2	Straight fitting	003-A1414VB	3	Tip (green)	004-TT110015VP	2
3	Nozzle cap	004-4723	9	Tip (blue)	004-TT11003VP	2
4	Check valve	003-1207VB	3	Tip (olive green)	004-800067-PT	2
5	Tee	003-TT14SQ	3	Tip Strainers	004-1203-100	6
6	Hose	002-9016	3ft			
7	Straight fitting	003-A1414	6			
8	Hose clamp	003-9002	9			
9	Elbow	003-SE14F	3			
10	Shield hanger	001-4704A	1			
11	Shield hanger	001-4704B	1			
12	Lynch pin	008-4576	2			
13	Nozzle body	004-4722	6			

## 4514B Installation Kit

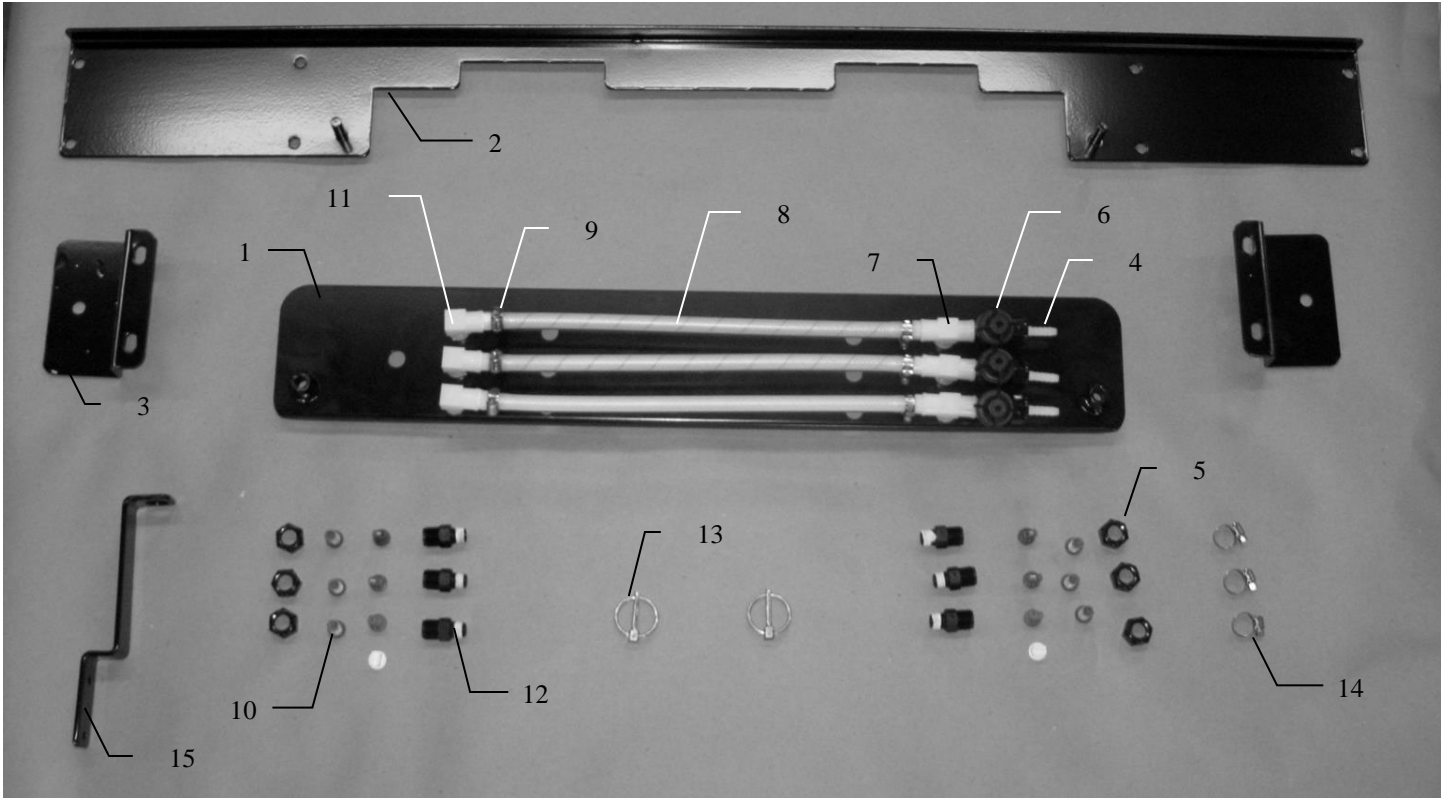

<u>Ref</u>	<u>Description</u>	<u>Part #</u>	<u>Qty</u>	<u>Description</u>	<u>Part #</u>	<u>Qty</u>
1	Spray shield	001-4431B	1	Tip (orange)	004-TT11001VP	2
2	Shield holder	001-4431KA	1	Tip (green)	004-TT110015VP	2
3	Mounting brackets	001-4431KB	2	Tip (blue)	003-TT11003VP	2
4	Straight fitting	003-A1414VB	3	Tip (olive green)	004-800067-PT	2
5	Nozzle cap	003-4723	9			
6	Check valve	004-1207VB	3			
7	Tee	003-TT14SQ	3			
8	Hose	002-9016	6			
9	Straight fitting	003-A1414	6			
10	Tip Strainers	004-1203-100	6			
11	Elbow	003-SE14F	3			
12	Nozzle body	004-4722	6			
13	Lynch pin	008-4576	2			
14	Hose clamp	002-9002	9			
15	End of bale sensor mount	001-4648K	1			
NP	End of bale sensor mount (Krone 12130 only)	001-4648K2	1			
NP	Not pictured					



## 4515B Installation Kit

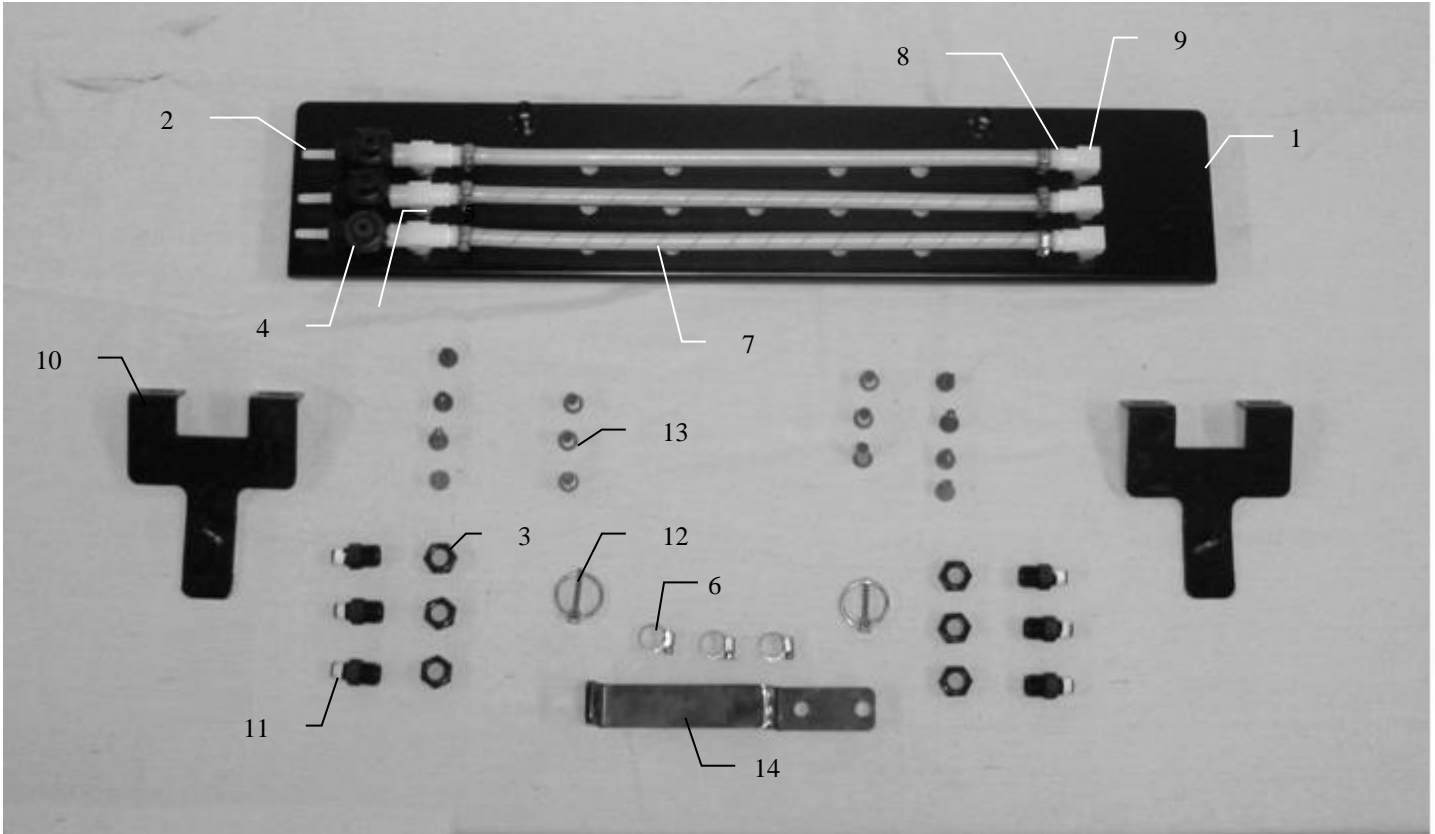

<u>Ref</u>	<u>Description</u>	<u>Part #</u>	<u>Qty</u>	<u>Description</u>	<u>Part #</u>	<u>Qty</u>
1	Spray shield	001-4435AS	1	Tip (orange)	004-TT11001VP	2
2	Straight fitting	003-A1414VB	3	Tip (green)	004-TT110015VP	2
3	Nozzle cap	004-4723	9	Tip (blue)	004-TT11003VP	2
4	Check valve	004-1207VB	3	Tip (olive green)	004-800067-PT	2
5	Tee	003-TT14SQ	3			
6	Hose clamp	003-9002	9			
7	Hose	002-9016	4ft			
8	Straight fitting	003-A1414	6			
9	Elbow	003-SE14F	3			
10	Shield holder	001-4435KS	2			
11	Nozzle body	004-4722	6			
12	Lynch pin	008-4576	2			
13	Tip strainers	004-1203-100	6			
14	End of bale sensor mount	001-4648K	1			
NP	End of bale sensor mount (Krone 12130 only)	001-4648K2	1			
NP	Not pictured					

# 4525B Installation Kit

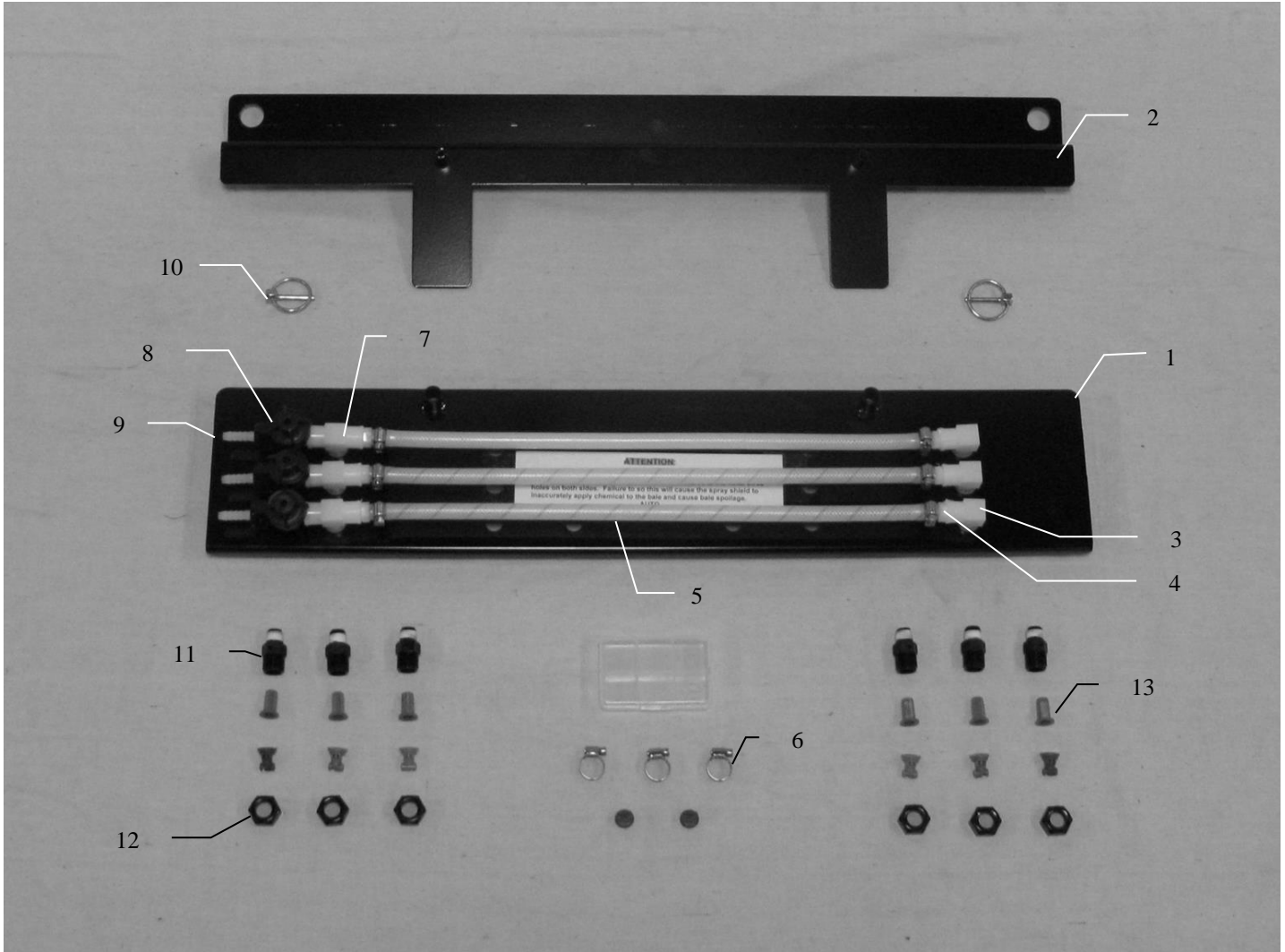

<u>Ref</u>	<u>Description</u>	<u>Part #</u>	<u>Qty</u>	<u>Description</u>	<u>Part #</u>	<u>Qty</u>
1	Spray shield	001-4435ES	1	Tip (olive green)	004-800067-PT	2
2	Shield holder	001-4435EK	1	Tip (orange)	004-TT11001VP	2
3	Elbow	003-SE14SQ	3	Tip (green)	004-TT110015VP	2
4	Straight fitting	003-A1414	6	Tip (blue)	004-TT11003VP	2
5	Hose	002-9016	6ft			
6	Hose clamp	003-9002	9			
7	Tee	003-TT14SQ	3			
8	Check valve	004-1207VB	3			
9	Straight fitting	003-A1414VB	3			
10	Lynch pin	008-4576	2			
11	Nozzle body	004-4722	6			
12	Nozzle cap	004-4723	9			
13	Tip strainer	004-1203-100	6			

## 4537B Installation Kit

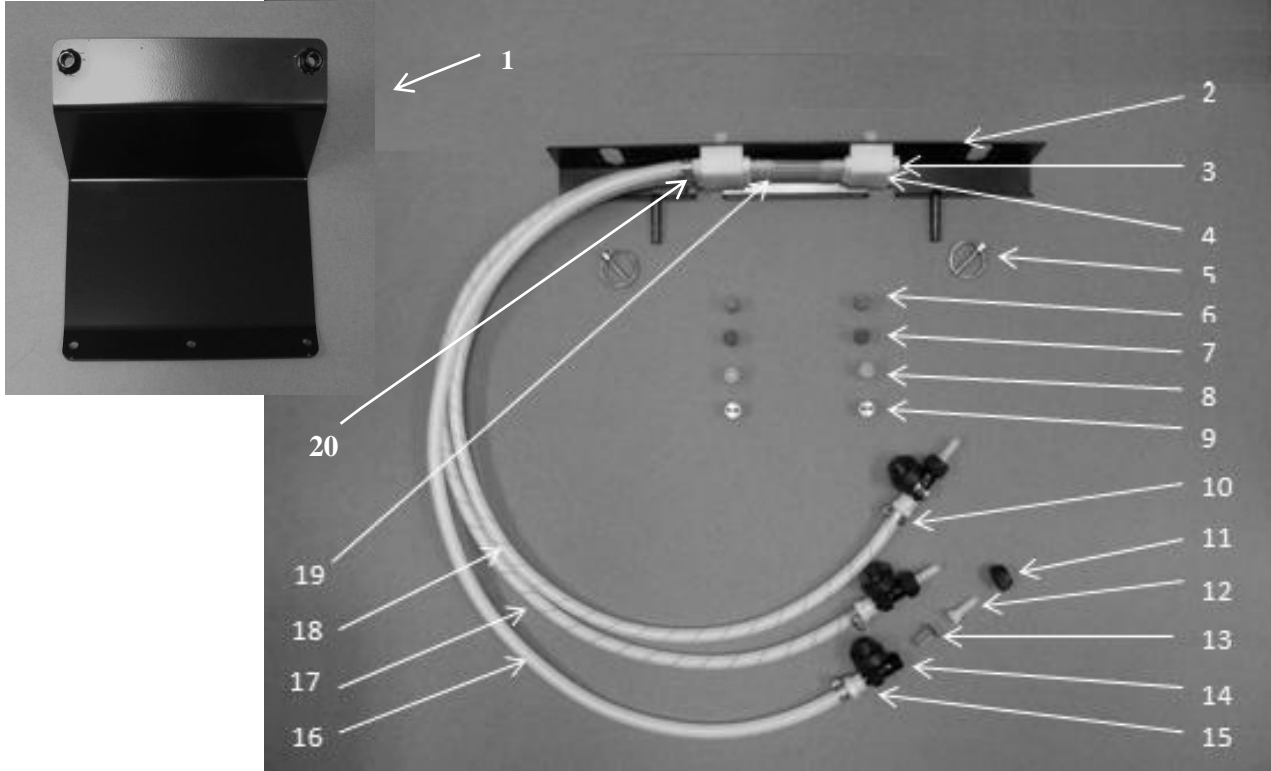

<u>Ref</u>	<u>Description</u>	<u>Part Number</u>	<u>Qty</u>	<u>Ref</u>	<u>Description</u>	<u>Part Number</u>	<u>Qty</u>
1	Holder	001-4435L	1	11	Cap	004-4723	3
2	Shield	001-4435NSX	1	12	Fitting	003-A1414VB	3
3	Fitting	003-F14	3	13	Strainer	004-1203-100	3
4	Manifold Block	001-4435NSB	2	14	Check Valve	004-1207VB	3
5	Lynch Pin	008-4576	2	15	Fitting	003-A1414F	3
6	Tip-Red	004-T8003-PT	2	16	Clear Tubing-1/4"	002-9016	3ft
7	Tip-Brown	004-T80015-PT	2	17	Blue Stripe Tubing	002-9016B	3ft
8	Tip-Pink	004-T8001-PT	2	18	Green Stripe Tubing	002-9016G	3ft
9	Tip-Stainless	004-T800067-SS	2	19	EVA-1/4"	002-9006	3ft
10	Hose Clamp	003-9002	15	20	Fitting	003-A1414	9
				NP	Mini Plano Box	008-9001	1

## 4539B Installation Kit

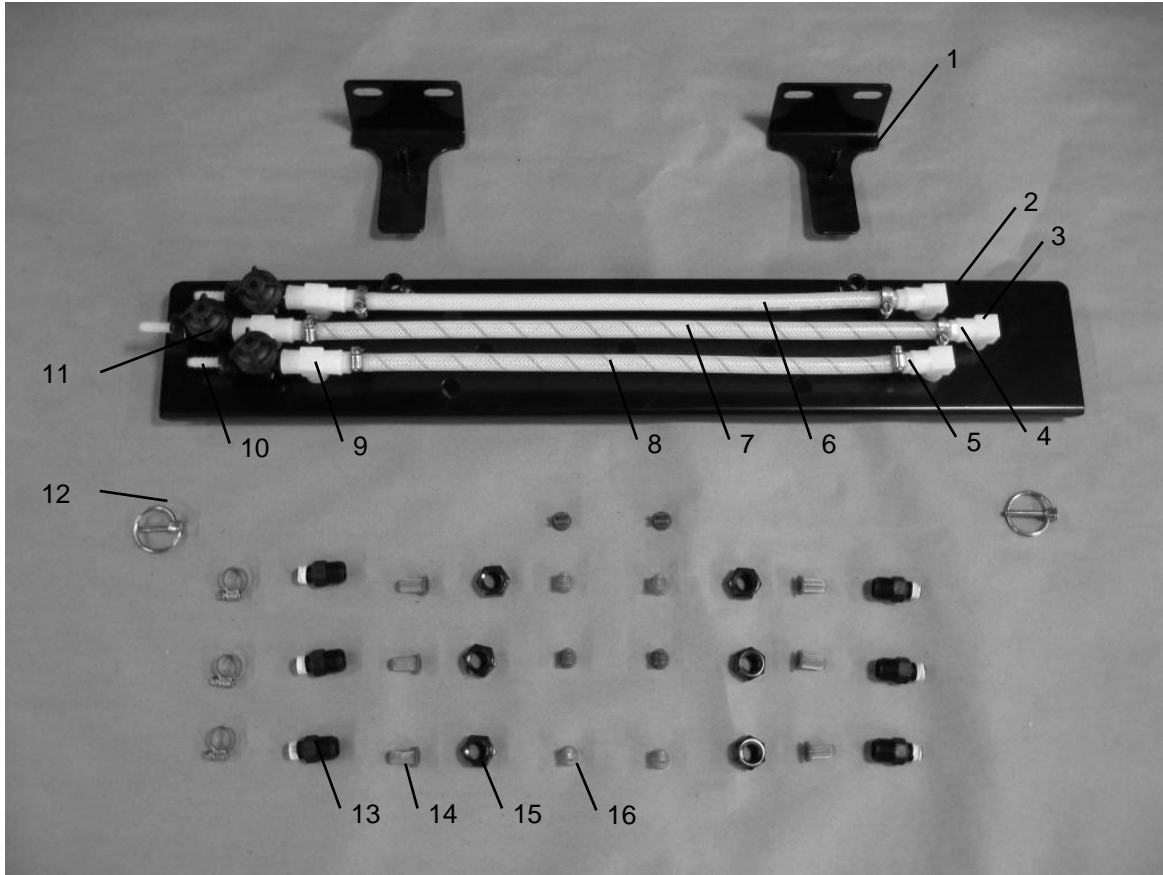

<u>Ref</u>	<u>Description</u>	<u>Part #</u>	<u>Qty</u>	<u>Ref</u>	<u>Description</u>	<u>Part #</u>	<u>Qty</u>
1	Shield Holder	001-4435KX	2	16	Nozzle Tips		
2	Spray Shield	001-4435AS	1		Tip (olive green)	004-800067-PT	2
3	Street Elbow	003-SE14F	3		Tip (orange)	004-TT11001VP	2
4	Fitting	003-A1414	6		Tip (green)	004-TT110015VP	2
5	Hose clamp	003-9002	9		Tip (blue)	004-TT11003VP	2
6	Hose-clear	002-9016	2ft	NP	Plano Box	008-9001	1
7	Hose-blue	002-9016B	2ft	NP	EOB Bracket	001-4648K2	1
8	Hose-green	002-9016G	2ft				
9	Tee	003-TT14SQ	3				
10	Fitting	003-A1414VB	3				
11	Check Valve	004-1207VB	3				
12	Lynch Pin	008-4576	2				
13	Nozzle Body	004-4722	6				
14	Strainer	004-1203-100	6				
15	Nozzle cap	004-4723	9				

## 4540B Installation Kit

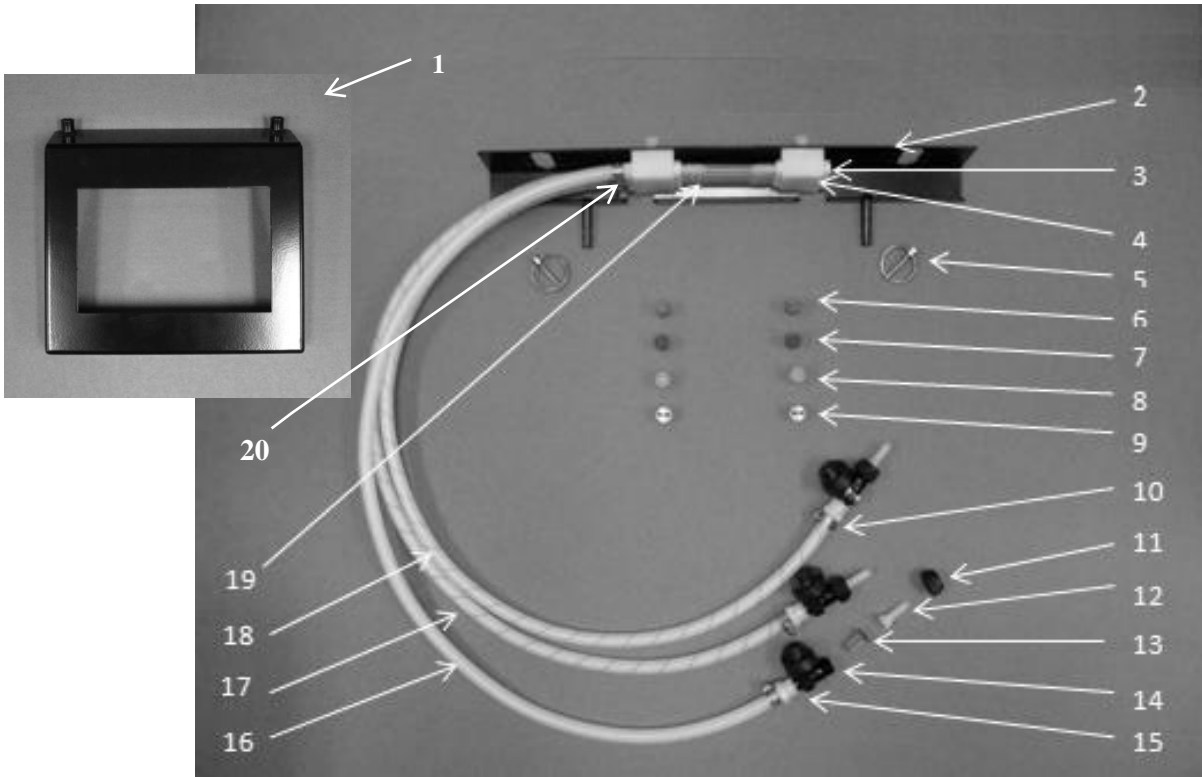

<u>Ref</u>	<u>Description</u>	<u>Part Number</u>	<u>Qty</u>	<u>Ref</u>	<u>Description</u>	<u>Part Number</u>	<u>Qty</u>
1	Holder	001-4435KC	1	11	Cap	004-4723	3
2	Shield	001-4435NSX	1	12	Fitting	003-A1414VB	3
3	Fitting	003-F14	3	13	Strainer	004-1203-100	3
4	Manifold Block	001-4435NSB	2	14	Check Valve	004-1207VB	3
5	Lynch Pin	008-4576	2	15	Fitting	003-A1414F	3
6	Tip-Red	004-T8003-PT	2	16	Clear Tubing-1/4"	002-9016	3ft
7	Tip-Brown	004-T80015-PT	2	17	Blue Stripe Tubing	002-9016B	3ft
8	Tip-Pink	004-T8001-PT	2	18	Green Stripe Tubing	002-9016G	3ft
9	Tip-Stainless	004-T800067-SS	2	19	EVA-1/4"	002-9006	1ft
10	Hose Clamp	003-9002	15	20	Fitting	003-A1414	9
				NP	Mini Plano Box	008-9001	1
				NP	EOB Bracket	001-4648K	1

# 4541B Installation Kit

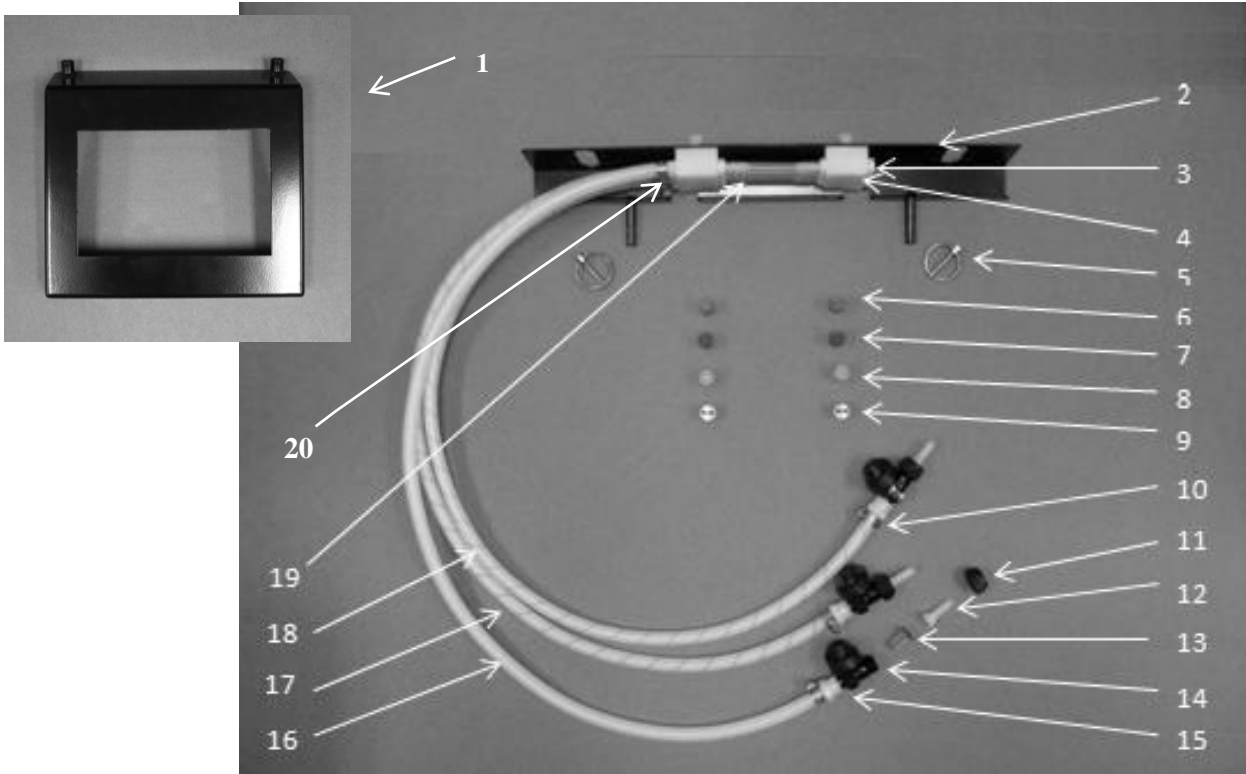

<u>Ref</u>	<u>Description</u>	<u>Part Number</u>	<u>Qty</u>	<u>Ref</u>	<u>Description</u>	<u>Part Number</u>	<u>Qty</u>
1	Holder	001-4435KC	1	11	Cap	004-4723	3
2	Shield	001-4435NSX	1	12	Fitting	003-A1414VB	3
3	Fitting	003-F14	3	13	Strainer	004-1203-100	3
4	Manifold Block	001-4435NSB	2	14	Check Valve	004-1207VB	3
5	Lynch Pin	008-4576	2	15	Fitting	003-A1414F	3
6	Tip-Red	004-T8003-PT	2	16	Clear Tubing-1/4"	002-9016	4ft
7	Tip-Brown	004-T80015-PT	2	17	Blue Stripe Tubing	002-9016B	4ft
8	Tip-Pink	004-T8001-PT	2	18	Green Stripe Tubing	002-9016G	4ft
9	Tip-Stainless	004-T800067-SS	2	19	EVA-1/4"	002-9006	1ft
10	Hose Clamp	003-9002	15	20	Fitting	003-A1414	9
				NP	Mini Plano Box	008-9001	1
				NP	EOB Bracket	001-4648K	1



# Vicon Large Square Star Wheel Guide

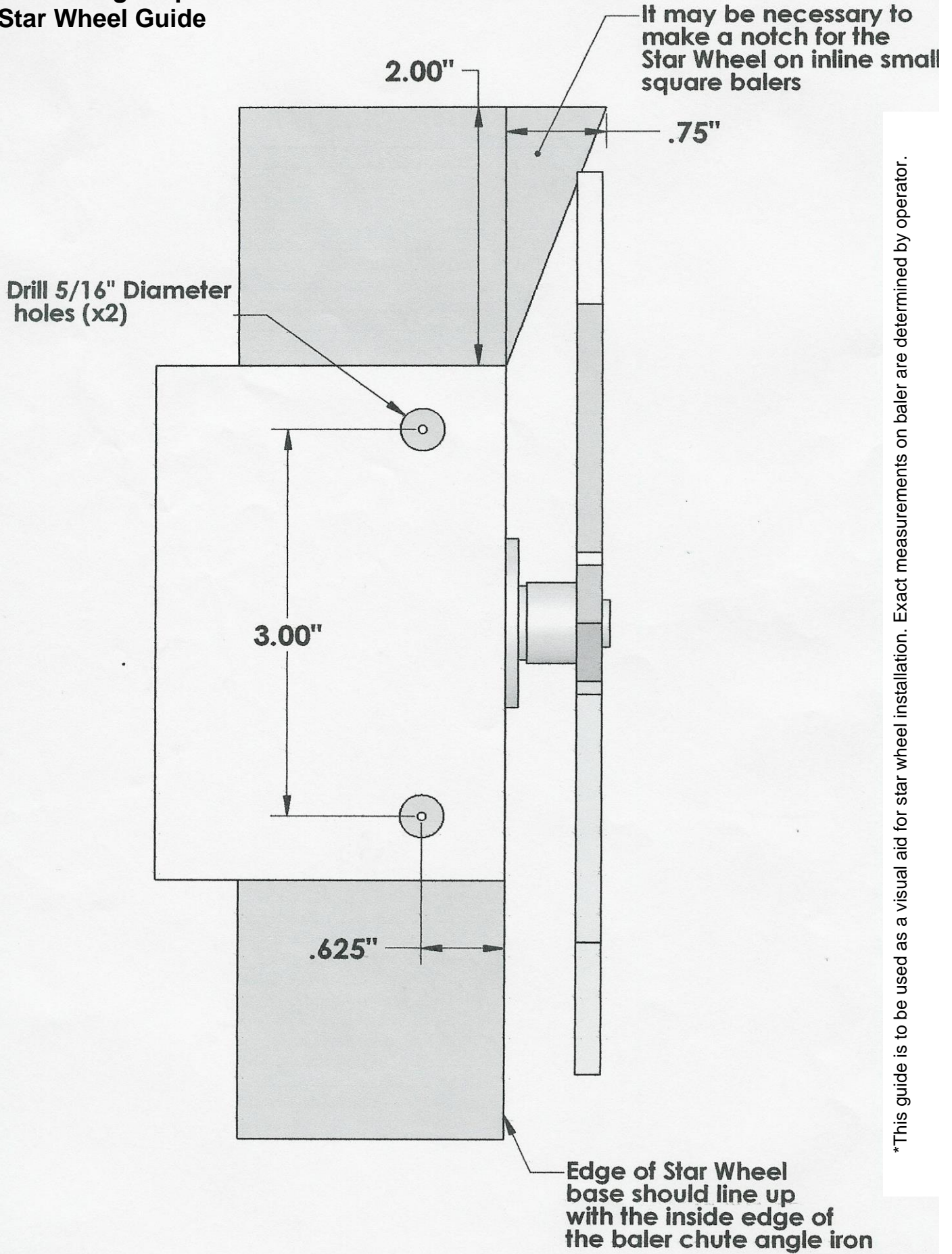

\*This guide is to be used as a visual aid for star wheel installation. Exact measurements on baler are determined by operator.

# Star Wheel Installation Guide

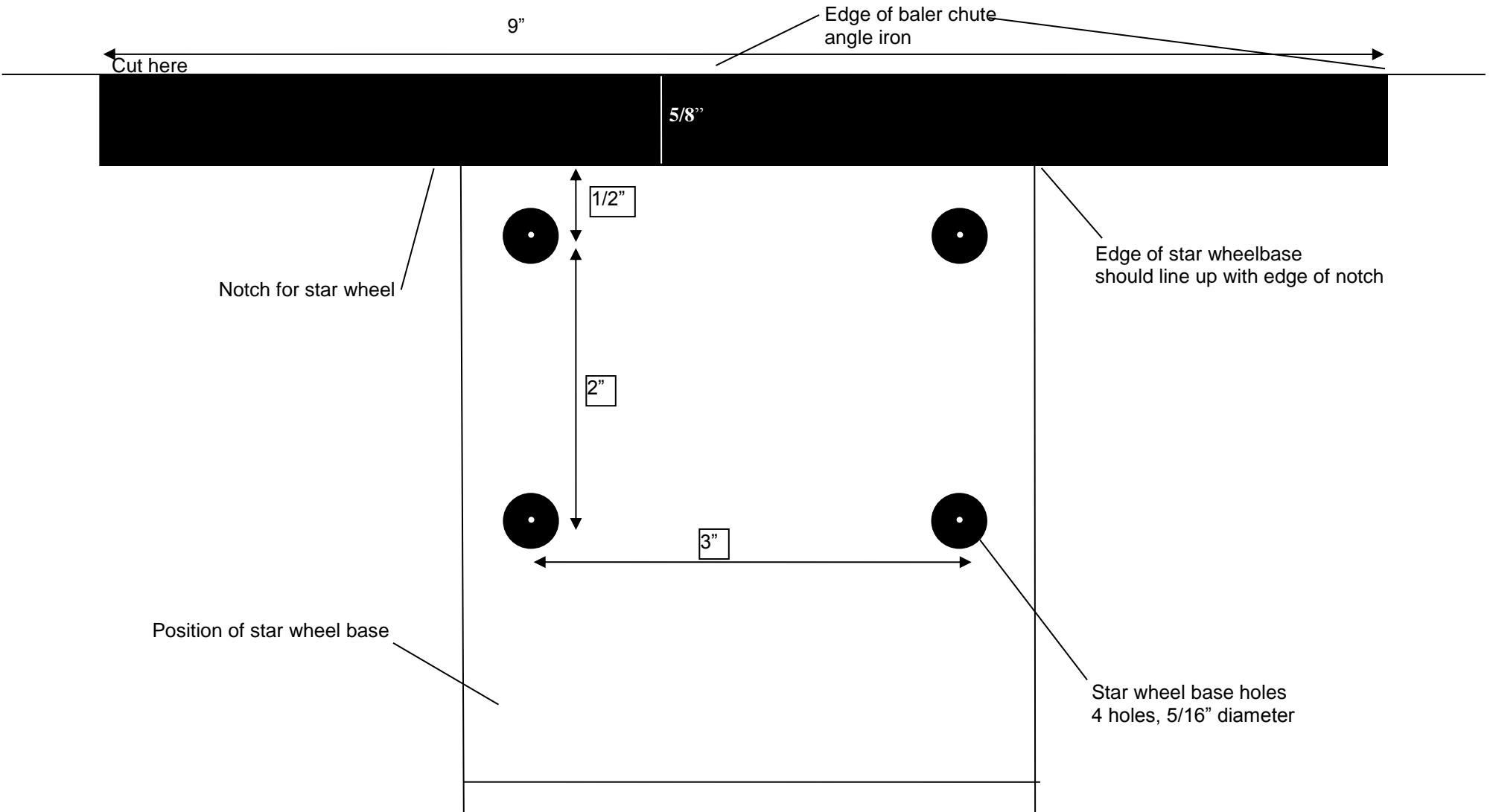

\*This guide is to be used as a visual aid for star wheel installation. Exact measurements on baler are determined by operator.

**Notes:**

## Notes:

## **Harvest Tec Inc. Warranty and Liability Agreement**

Harvest Tec, Inc. will repair or replace components that are found to be defective within 12 months from the date of manufacture. Under no circumstances does this warranty cover any components which in the opinion of Harvest Tec, Inc. have been subjected to negligent use, misuse, alteration, accident, or if repairs have been made with parts other than those manufactured and obtainable from Harvest Tec, Inc.

Our obligation under this warranty is limited to repairing or replacing free of charge to the original purchaser any part that in our judgment shows evidence of defective or improper workmanship, provided the part is returned to Harvest Tec, Inc. within 30 days of the failure. If it is determined that a non-Harvest Tec branded hay preservative has been used inside the Harvest Tec applicator system where the failure occurred, then Harvest Tec reserves the right to deny the warranty request at their discretion. Parts must be returned through the selling dealer and distributor, transportation charges prepaid.

This warranty shall not be interpreted to render Harvest Tec, Inc. liable for injury or damages of any kind, direct, consequential, or contingent, to persons or property. Furthermore, this warranty does not extend to loss of crop, losses caused by delays or any expense prospective profits or for any other reason. Harvest Tec, Inc. shall not be liable for any recovery greater in amount than the cost or repair of defects in workmanship.

There are no warranties, either expressed or implied, of merchantability or fitness for particular purpose intended or fitness for any other reason.

This warranty cannot guarantee that existing conditions beyond the control of Harvest Tec, Inc. will not affect our ability to obtain materials or manufacture necessary replacement parts.

Harvest Tec, Inc. reserves the right to make design changes, improve design, or change specifications, at any time without any contingent obligation to purchasers of machines and parts previously sold.

Revised 4/17

**HARVEST TEC, INC.**  
**P.O. BOX 63**  
**2821 HARVEY STREET**  
**HUDSON, WI 54016**  
**PHONE: 715-386-9100**  
**1-800-635-7468**  
**FAX: 715-381-1792**