

Installation Manual

Model 664M

Automatic Preservative Applicator



HayBoss™
G2

(intentionally blank)

Harvest Tec Model 664M Installation Table of Contents

	<u>PAGE</u>
Introduction	4
System Requirements	4
Tools Needed	4
Installation of Controls and Harnesses	5-6
1. Installation of Dual Channel Processor (DCP)	5
DCP or PIP Location for AGCO Balers	5
2. Main Harness and Baler Interface Routing and Connections	6
Wiring Diagram	7
Pin Outs	8-10
Parts Breakdown	11
Controls and Harnesses	11
Warranty Statement	12

Introduction

Thank you for purchasing a HayBoss G2 Model 696M Hay Preservative Applicator. This 696M applicator system has been designed to plug directly into the baler's ISOBUS and display on a C1000 monitor. As well as the option of operation through an Apple iPad (not included) using the Hay App. The 696M Preservative Applicator System offers these advantages:

1. Operation coordinated with baler operation
2. Less cab clutter providing better visibility
3. Ease of use with all information on one screen
4. Records kept together
5. And the system is ready for future updates.

This manual will take you through the steps for installing the automatic applicator. If you are unsure about installing the system after consulting this manual, please contact your local authorized dealership for additional assistance. If you are in need of parts for the system please see the parts breakdown in the back of this manual and contact your local authorized dealer to order the parts.

Right and Left sides are determined by facing in the direction of forward travel.

System Requirements

**The Baler Processor must have Version 3.3 or higher.
C1000 must have version 3.0.1 or higher**

*Requirement to run iPad option are 3rd Generation iPad (2012) or newer running the current operating system.

Tools Needed:

- Standard wrench set
- Side cutter

1. Installation of Dual Channel Processor (DCP)

The Dual Channel Processor (DCP) has the same bolt pattern as the Precision Information Processor (PIP) you will be removing. The location of the main controller does not change so use the same holes and install the new Dual Channel Processor (DCP) in the same location with two 5/16" x 1" bolts, two 5/16" x 1-1/4" bolts, locks, fender washers and hex nuts. Mount the DCP cover over the top of the DCP and secure with the hardware using the 5/16" x 1-1/4" bolts on the top with the DCP shield.

DCP or PIP Location

AGCO Balers

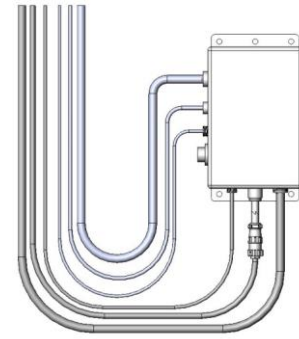

Figure 1



Figure 2

2. Main Wire Harness and Baler Interface Harness Routing and Connections



A. Route harness 006-6650LS2 along this path or similar inside of the baler. Keep harnesses away from moving parts and hydraulic hoses. Secure with existing cable clamps or use cable ties. When all connections are made to the DCP secure wires as shown above to allow for water to be shed away from the DCP.



B. Under the chamber locate the Active Terminator from the end of the baler harness. It is located at the right rear corner of the baler frame. Attach Baler Interface Harness (006-6650VA) to that location. Reconnect Active Terminator to open port of that same harness (006-6650VA). If your baler does not have a Terminator at this location please call Harvest Tec.

If your baler has the White Terminating Resistor you will need to attach the Pre 2012 AGCO Integration Harness (006-6650VAX) to the end of the Baler Interface harness (006-6650VA). Please contact Harvest Tec for this harness. This style terminator may be next to the Baler's Main Processor.

Installation of Bluetooth Receiver

Locate a safe location in the cab of the tractor to place the Bluetooth Receiver (030-6672B). Recommended location is as close to the iPad being used as possible.

Connect the Power / Communication harness (006-6650TM) to the bottom of the receiver (right).



Wiring Diagram

- A. The **Baler Power/Communication Harness** (006-6650LS2) will attach to the open port of the Tractor **Harness** (006-6650TM) and run back to the **Dual Channel Processor** (006-6671LS). Connect the large plug of the Baler Power/Communication Harness (006-6650LS) to the bottom (shorter side) of the DCP.
 - B. Attach the **Baler Interface Harness** (006-6650VA) in between the short whip cable hardwired to the DCP and the main Power/Communication Harness (006-6650LS2). Make sure Active Terminator removed from the top of the baler processor is attached to Baler Interface Harness (006-6650VA).
 - C. Install green terminator (006-5650Z) to the port labeled **Modular Port** on the Pump Controller (006-5672).
 - D. Attach moisture and bale rate harness (006-7303H) as well as the end of bale harness (006-7400) to the DCP (006-6671LS).
 - E. Attach the Pump Control Harness (006-5650F3M) between the Pump Controller (006-5672) and the DCP (006-6671LS).
 - F. Connect Keyed Power Extension harness (006-5650K) to a keyed power source.
 - G. Connect the Bluetooth Receiver (030-6672B) to the Communication Harness (006-6650TM).
- Note: The Optional Port and the Data Transfer Port are not used in this application.

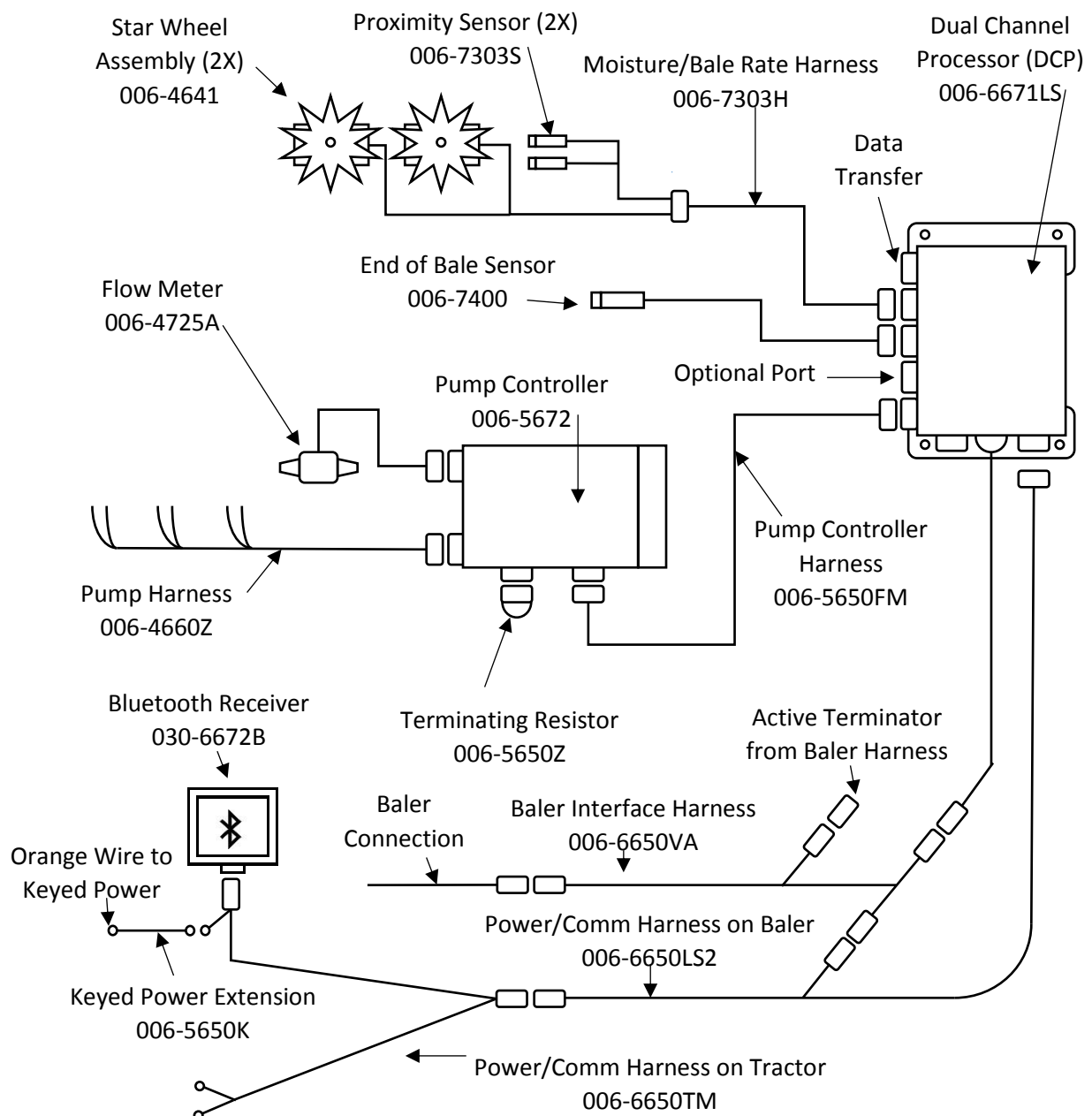

Pin Outs

Power/Comm Harness 006-6650TM at Hitch

Pin 1	Red	+12V Power to TSD
Pin 2	Red	+12V Power to DCP
Pin 3	Orange	Keyed Power
Pin 4	Gray	Shield
Pin 5	Green	HT Can Low
Pin 6	Yellow	HT Can Hi
Pin 7	Orange	Can1 Hi
Pin 8	Black	Ground from TSD
Pin 9	Black	Ground from DCP
Pin 10	Blue	Can1 Low



Power/Comm Harness 006-6650LS2 at Hitch

Pin 1	Red	+12V Power to TSD
Pin 2	Red	+12V Power to DCP
Pin 3	Orange	Keyed Power
Pin 4	Gray	Shield
Pin 5	Green	HT Can Low
Pin 6	Yellow	HT Can Hi
Pin 7	Orange	Can1 Hi
Pin 8	Black	Ground from TSD
Pin 9	Black	Ground from DCP
Pin 10	Blue	Can1 Low

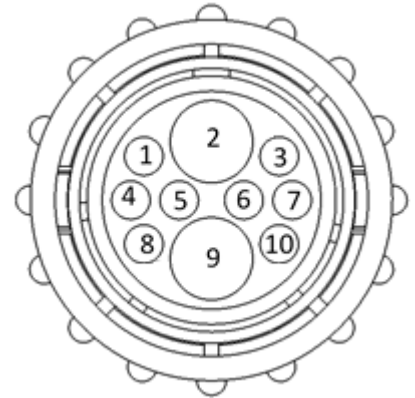

Bluetooth Receiver on Harness 006-6650TM

Pin 1	Red	+12V Power from DCP
Pin 2	Black	Ground from TSD
Pin 3	Yellow	HT Can Low
Pin 4	Gray	Shield
Pin 5	Green	HT Can Hi
Pin 6	Orange	Can1 Hi
Pin 7	Blue	Can1 Low

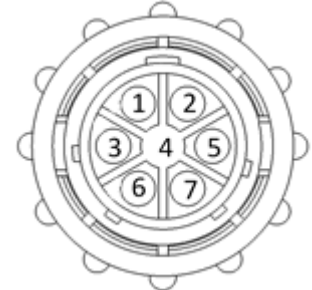

006-6650VA to DCP Whip

Pin 1	Red	Can Power
Pin 2	Black	Can Ground
Pin 3	Yellow	HT Can Hi
Pin 4	Gray	Shield
Pin 5	Green	HT Can Low
Pin 6	Orange	Can1 Hi
Pin 7	Blue	Can1 Low



Pin Outs (continued)

006-6650VA to 006-6650LS2

Pin 1	Red	Can Power
Pin 2	Black	Can Ground
Pin 3	Yellow	HT Can Hi
Pin 4	Gray	Shield
Pin 5	Green	HT Can Low
Pin 6	N/A	
Pin 7	N/A	



006-6650VA Harness to Baler Plug

Pin A	N/A	
Pin B	Red	TBC Power
Pin C	N/A	
Pin D	Gray	TBC Ground
Pin E	Orange	Can1 Hi
Pin F	Blue	Can1 Low

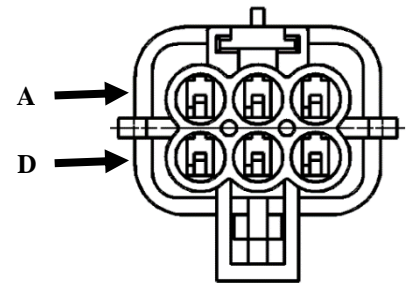

Main Power Connector on Dual Channel Processor (DCP)

Pin 1	Red	+12V Power from tractor
Pin 2	Black	Ground from tractor
Pin 3	Orange	Keyed power

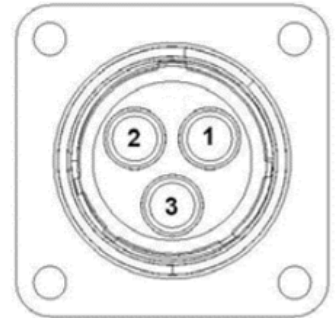

Star Wheel and Bale Rate Sensor connector on DCP

Pin 1	Blue	+12V Power
Pin 2	Orange	Ground
Pin 3	Black	Signal for sensor 1
Pin 4	White	Signal for sensor 2
Pin 5	N/A	
Pin 6	N/A	
Pin 7	N/A	
Pin 8	Violet	Star wheel input 1
Pin 9	Brown	Star wheel input 2



End of Bale sensor on DCP

Pin 1	Brown	Sensor Power
Pin 2	Blue	Sensor Ground
Pin 3	N/A	
Pin 4	Black	Signal from Sensor

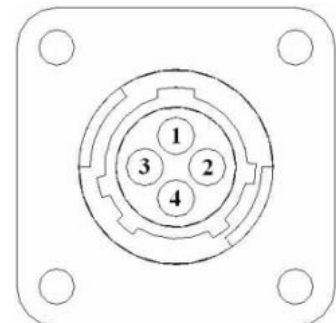

Pin Outs (continued)

Pump Communication Plug on DCP

Pin 1	Red	+12V Can
Pin 2	Red	+12V Power
Pin 3	Gray	Shield
Pin 4	Green	Comm Channel OH
Pin 5	Yellow	Comm Channel OL
Pin 6	Blue	Comm Channel IH
Pin 7	Orange	Comm Channel IL
Pin 8	Black	Can Ground
Pin 9	Black	Power Ground
Pin 10	N/A	

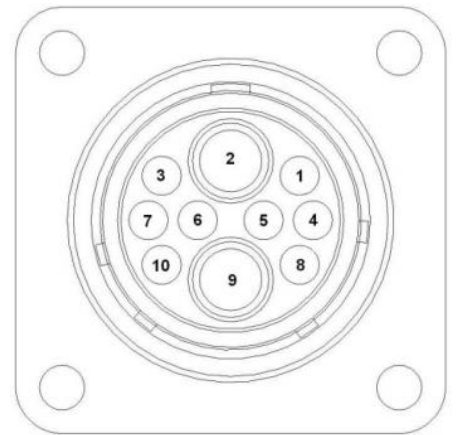

Pump Connection Colors

Pin 1	Black with Orange Stripe	Pump 1 Ground
Pin 2	Black with Green Stripe	Pump 2 Ground
Pin 3	Black with Yellow Stripe	Pump3 Ground
Pin 4	N/A	
Pin 5	Orange with Black Stripe	Pump 1 Positive
Pin 6	Green with Black Stripe	Pump 2 Positive
Pin 7	Yellow with Black Stripe	Pump 3 Positive

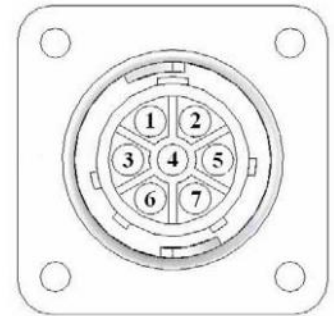

Flow Meter Connection on Pump Controller

Pin 1	White	+5-12V Power
Pin 2	Green	Ground
Pin 3	Brown	Signal
Pin 4	Black	Shield

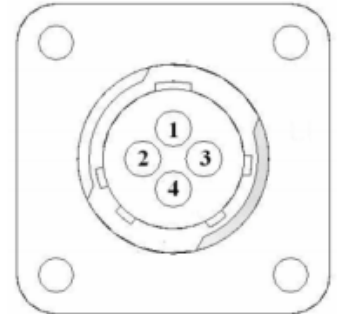

Connector for Crop Eyes on DCP

Pin 1	Red	+12V Power
Pin 2	Black	Ground
Pin 3	White	Signal
Pin 4	N/A	

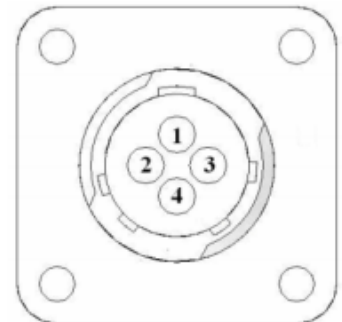

Parts Breakdown (Converting a 500 Series to a 600 Series)



<u>Ref</u>	<u>Description</u>	<u>Part Number</u>	<u>Qty</u>
1	Terminating Resistor 500 Series-green	001-5650Z	1
2	DCP Main Control LS 600 Auto	001-6671LS	1
3	Dust Plugs-only one included	006-5651PLUGS	1
4	Key Switch Wire-orange	006-5650K	1
5	DCP Baler Harness 30"	006-6650LS2	1
6	DCP Tractor Harness	006-6650TM	1
7	DCP Baler ISO/VT Harness	006-6650VA	1
8	Bluetooth Receiver	030-6672B	1
NP	Pre 2012 AGCO Integration Harness (not included)	006-6650VAX	1
NP	Optional ISOBUS Adapter Plug (not included)	006-6670A	1

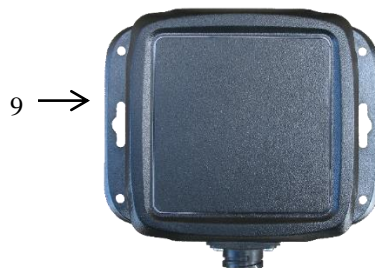

Harvest Tec Inc. Warranty and Liability Agreement

Harvest Tec, Inc. will repair or replace components that are found to be defective within 12 months from the date of manufacture. Under no circumstances does this warranty cover any components which in the opinion of Harvest Tec, Inc. have been subjected to negligent use, misuse, alteration, accident, or if repairs have been made with parts other than those manufactured and obtainable from Harvest Tec, Inc.

Our obligation under this warranty is limited to repairing or replacing free of charge to the original purchaser any part that in our judgment shows evidence of defective or improper workmanship, provided the part is returned to Harvest Tec, Inc. within 30 days of the failure. If it is determined that a non-Harvest Tec branded hay preservative has been used inside the Harvest Tec applicator system where the failure occurred, then Harvest Tec reserves the right to deny the warranty request at their discretion. Parts must be returned through the selling dealer and distributor, transportation charges prepaid.

This warranty shall not be interpreted to render Harvest Tec, Inc. liable for injury or damages of any kind, direct, consequential, or contingent, to persons or property. Furthermore, this warranty does not extend to loss of crop, losses caused by delays or any expense prospective profits or for any other reason. Harvest Tec, Inc. shall not be liable for any recovery greater in amount than the cost or repair of defects in workmanship.

There are no warranties, either expressed or implied, of merchantability or fitness for particular purpose intended or fitness for any other reason.

This warranty cannot guarantee that existing conditions beyond the control of Harvest Tec, Inc. will not affect our ability to obtain materials or manufacture necessary replacement parts.

Harvest Tec, Inc. reserves the right to make design changes, improve design, or change specifications, at any time without any contingent obligation to purchasers of machines and parts previously sold.

Revised 4/17

HARVEST TEC, INC.
P.O. BOX 63
2821 HARVEY STREET
HUDSON, WI 54016
PHONE: 715-386-9100
1-800-635-7468
FAX: 715-381-1792
Email: info@harvesttec.com