

Operation Manual

300 Series Small Square Baler Models

25 & 55 gallon Preservative Applicators

HARVEST
**TEC** *Equipment and Products
for Quality Hay.™*

P.O. Box 63 • 2821 Harvey Street • Hudson, WI 54016
800-635-7468 • www.harvesttec.com

(intentionally blank)

Small Square Baler Models Operation Table of Contents

	<u>Page</u>
Introduction	5
Model Reference Kit	5
Safety	5-6
Safety Sign Definitions	6
Preparing the applicator for operation	7-8
Filling the tank	7-8
Model 344,350 & 351	7
Model 345	8
Operation of the main ball valve	8
Connecting the power harness	8
Bluetooth Operation	9-10
Turn On / Off iPad	9
Downloading Harvest Tec App	9
Turn off Auto-Lock Function	10
Shutting Down the Hay App	10
Operating the Harvest Tec App	11-13
Devise Selection	11
Demo Mode	12
Manual Selection	12
Recommended Preservative	12
Tab Descriptions	13
Automatic mode	13
Manual mode	13
Diagnostics	13
Setup mode	13
Job records	13
Screen menus	14-16
Automatic mode	14
Manual mode	15
Setup mode	15
Job Records	16
First time and annual startup instructions	17
Checking and priming the pumps	17
Setting up system for initial use	18-19
Application rate	18
Selecting high and low tips	18
Baling rate	19
Operating Instructions	20-22
Automatic mode	20
Manual mode	21
Job records	22
Software versions	22
Bluetooth Receiver Lights	23
Maintenance	23-25
Maintenance schedule	23
Diagnostics & Filter bowl cleaning	23
Tips & tip screen, Tank lid cleaning	24
Dielectric grease connections	24
Rebuild pumps	24
Battery connections	24
Solenoid Valves	24
Miscellaneous maintenance	25

Table of Contents (continued)

	<u>Page</u>
Winter storage	25
Wiring Diagram	26
Common Questions	27
Troubleshooting	28
Pin Outs	30-31
Parts breakdown	31-49
344 Base Kit	32
345 Base Kit	32
350 Base Kit	33
351 Base Kit	33
Pump Assembly	34
Star Wheel Sensors	35
Hoses & Drain Fill Kit	35
Controls and Wiring Harnesses	36
End of Bale Sensor Kits	36
300 Solenoid Packages	37
Parts Bags	38
Optional iPad Mini Mounting Kit (2014MK)	39
Optional iPad Display Kit (4670DK)	40
4409C Install kit	41
4410C Install kit	42
4412C Install kit	43
4415C Install kit	44
4416C Install kit	45
4485C Install kit	46
4502C Install kit	47
4506C Install kit	48
4507C Install kit	49
Notes	50
Warranty statement	51

Introduction

Read this manual carefully to ensure correct steps are done to operate the applicator. This applicator is designed to apply Harvest Tec buffered propionic acid. Use of alternative products may cause complications. Including inaccurate readings from the flow meter and damage to all parts. Resulting in the warranty being void. The applicator can be installed on many square balers with the proper installation kit. Before installing the unit on the baler, make sure you have the proper installation kit (See the chart below). If you are unsure about your installation kit contact your local authorized dealer for specifications. There is a parts break down in the back of this manual for the applicator.

Right and Left sides are determined by facing in the direction of forward travel.

****iPad Mini or iPad 3rd Generation (2012) or newer, running the current iOS operating system or one version previous required for iPad option***

Model Kit Reference

Baler Make	Baler Model	Model Number	Installation Kit	Tank Size
AGCO	7105, 7110, 7115, 7120, 1835, 1837, 1837, 1841	344	4416C	55 Gallon
Case IH	8500 Series	344	4416C	55 Gallon
Case IH	SBX 520, 521	345	4409C	25 Gallon
Case IH	SBX 530, 540, 550, SB531, SB541, SB551	345	4415C	25 Gallon
Case IH	SBX 530, 540, 550, SB531, SB541, SB551	351	4415C	55 Gallon
Challenger	SB 34, 36, 44	344	4416C	55 Gallon
Freeman	270, 370	350	4506C	55 Gallon
Hesston	4550, 4570, 4590, 4600, 4655	344	4416C	55 Gallon
Hesston	4690N, 4690S	350	4502C	55 Gallon
John Deere	328, 336, 338, 346, 347, 348	345	4410C	25 Gallon
Massey Ferguson	1835, 1836, 1837, 1838, 1839, 1840, 1841, 1842	344	4416C	55 Gallon
Massey Ferguson	1843N, 1843S	350	4502C	55 Gallon
Massey Ferguson	1844N, 1844S	350	4485C	55 Gallon
New Holland	200, 300 Series, 565 & BC5050	345	4409C	25 Gallon
New Holland	570, 575, 580, BC5060, BC5070, BC5080	345	4415C	25 Gallon
New Holland	570, 575, 580, BC5060, BC5070, BC5080	351	4415C	55 Gallon
New Holland	585, BB900	350	4507C	55 Gallon
New Idea	7205, 7210, 7215	344	4416C	55 Gallon
Welger	AP630, AP730, AP830	345	4412C	25 Gallon

Safety

Carefully read all the safety signs in this manual and on the applicator before use. Keep signs clean and in good working order. Replace missing or damaged safety signs. Replacement signs are available from your local authorized dealer. See your installation manual or under the replacement parts section for the correct part numbers.

Keep your applicator in proper working condition. Unauthorized modifications to the applicator may impair the function and/or safety of the machine. Carefully read and understand all of the baler safety signs before installing or servicing the baler. Always use the supplied safety equipment on the baler to service the applicator.

Safety Signs Definitions

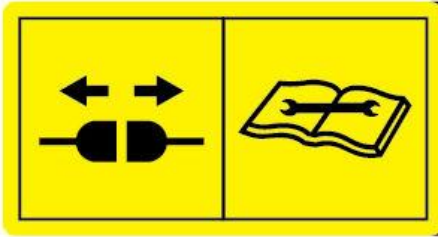

Number 1
Spraying hazard. Disconnect power before servicing the applicator
Part no. DCL-8003



Number 2
Falling hazard. Do not step in this area.
Part no. DCL-8002



Number 3
Use caution when working around chemicals. **Wear all protective equipment according to the label of the product.**
Part no. DCL-8001



Number 4
Read and understand the operator's manual before using or working around the equipment.
Part no. DCL-8000

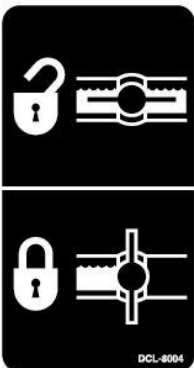

Number 5
Open (unlocked) and closed (locked) position of the ball valve.
Part no. DCL-8004

Preparing the Applicator for Operation

After the Applicator has been installed on the baler, follow the below steps to prepare for operating the applicator both safely and correctly.

Filling the tank through the Drain / Fill kit (Model 344, 350 & 351)

Read the label of the product being filled into the tank to determine what individual protective measures need to be taken. Locate the drain/fill line on the baler. Open the cam-couplers (A) and remove the protective plug (B). Insert the male coupler (found on transfer pump) into the female cam and close the cams (A).

To open the ball valve (C) turn the handle so it is vertical. After the ball valve has been turned on switch the pump to the On position. Monitor the level on the tank visually and shut off the pump before over filling. Once the pump is turned off, close the ball valve and remove the male coupler.

The handle of the ball valve (C) will be horizontal when closed. Reinstall the protective plug and close the cams. The Harvest Tec model 9212 transfer pump is recommended for this process.

Water is recommended for first time and annual start up procedures.



Drain/Fill line on the baler

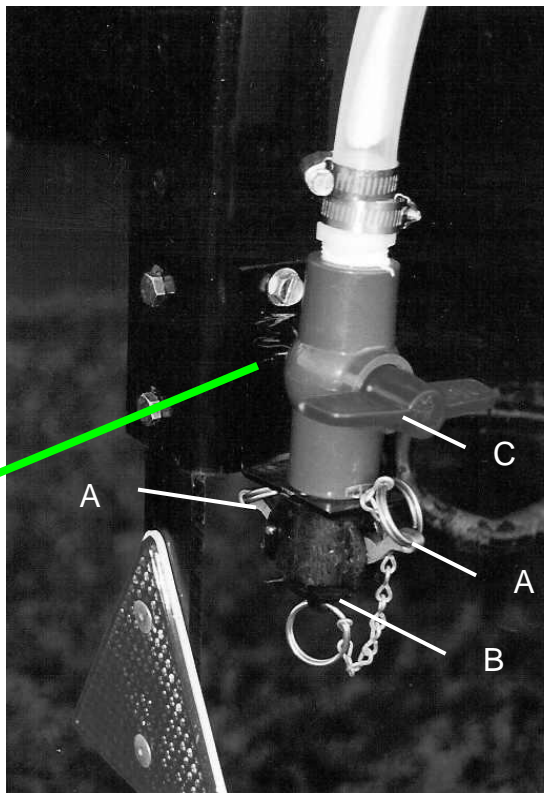

Enlarged view of the drain/fill line valve and cam-coupler assembly.

Filling the tank through the tank lid opening (Model 344, 345, 350, 351)

Read the label of the product being filled into the tank to determine what individual protective measures need to be taken. Clean the tank lid area and unscrew the lid. Transfer product from the container into the tank.

Water is recommended for first time and annual start up procedures.

Operation of the Main Ball Valve

The ball valve should be closed at all times when the applicator is not being used. The valve should also be closed when any service work is being done to the baler or applicator.

The valve is located next to the pump and by the applicator tank. The arrow below points at the valve.

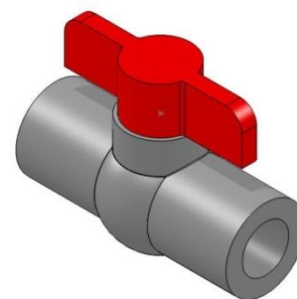

Valve
open

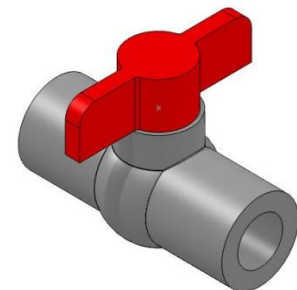

Valve
closed

Connecting the power harness

The power harness that supplies power from the tractor battery to the applicator pump has a disconnect at the hitch. Connect the two together for operation. Always disconnect before servicing the applicator or baler.

WARNING: Stop tractor engine and shift to park, set brakes and remove key before leaving the tractor.

Bluetooth Operation

Turn On / Off iPad using the Sleep/Wake button

*(Info from Apple User's Guide)

Turn iPad on. Hold down the Sleep/Wake button until Apple logo appears. iPad will take a moment to load.

You can lock iPad and put it to sleep when you're not using it. Locking iPad puts the display to sleep, saves the battery, and prevents anything from happening if you touch the screen.

Sleep/Wake Button



When you are not going to use the iPad for an extended period of time put the unit into sleep mode by pressing the Sleep/Wake button. Press Sleep/Wake button to wake iPad and then unlock iPad by entering passcode.

Turn iPad off. Hold down the Sleep/Wake button for a few seconds until the slider appears onscreen, then drag the slider to the right.

Downloading Harvest Tec App

1. If iPad does not have Wi-Fi turned on, select the Settings tab  then select the Wi-Fi tab (below).

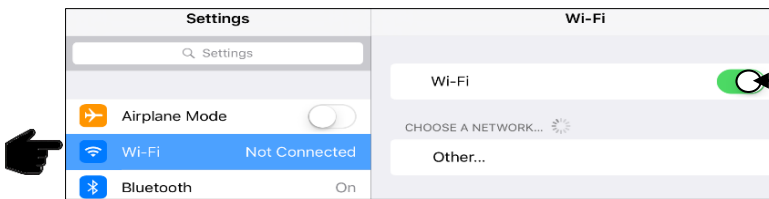

2. Turn Wi-Fi on by sliding button to the right.
*Green bar indicates ON

3. Use same process to turn on Bluetooth function

4. Select an available network when detected by the iPad, shown in area above that currently says 'Other.'

5. Select App Store icon (below) and open. *You will need a Wi-Fi connection available to view App Store.



****The Harvest Tec system WILL NOT appear under the Bluetooth tab in the Setting App. Open the Hay App to connect.**

Download the Hay App in the App Store by searching for 'Hay App' in the search bar in the top right corner of screen (right):

*The advertisements displayed on the App Store screen will change.

The app will have the icon as shown:



Hay App

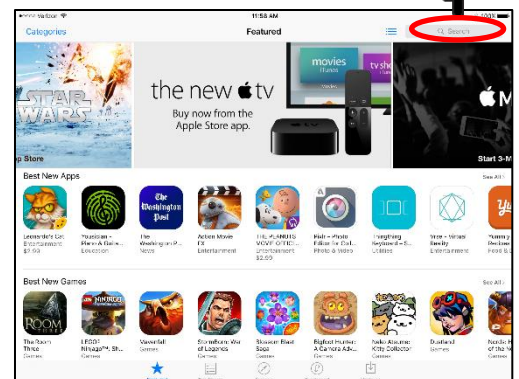

Note: Operation requires iPad Mini or iPad 3rd Generation (2012) or newer, running the current iOS operating system or one version previous required for iPad option.

Turn Off Auto-Lock Function

To ensure that your iPad does not periodically auto-lock or 'sleep' during periods of inactivity the auto-lock timer must be changed.

Under the Setting tab (illustrated previously), select the General settings tab (below left), and change the timer setting to Never (below right).

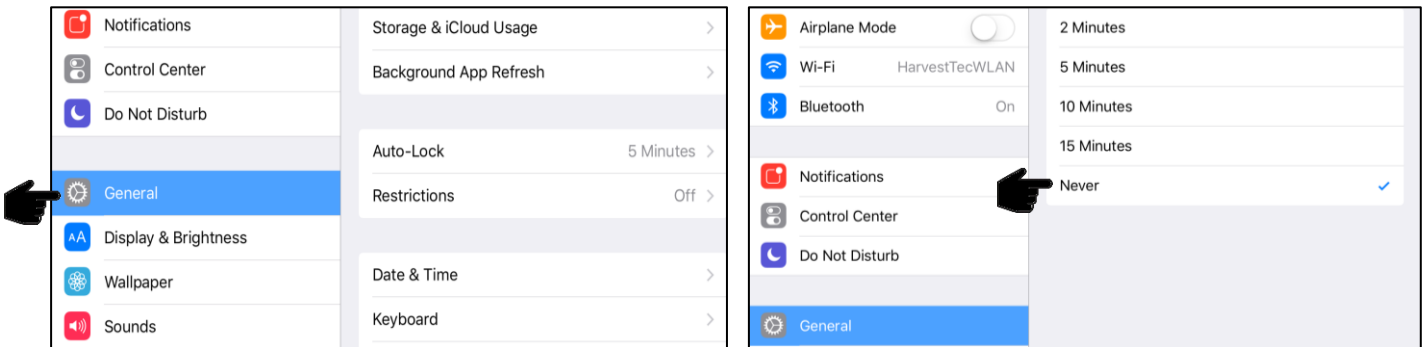

Shutting Down the Hay App

1. To shut down the Hay App double click the home button (Figure A). This will show the open apps that are running on your iPad (Figure B).
*Note: By pressing the home button one time to return to the home screen, the Hay App **does not** shut down. The system will however, stop applying preservative after 10 seconds.



2. Slide the app you want to shut down by sliding the app toward the top of the iPad, until the app is no longer visible (Figure C).

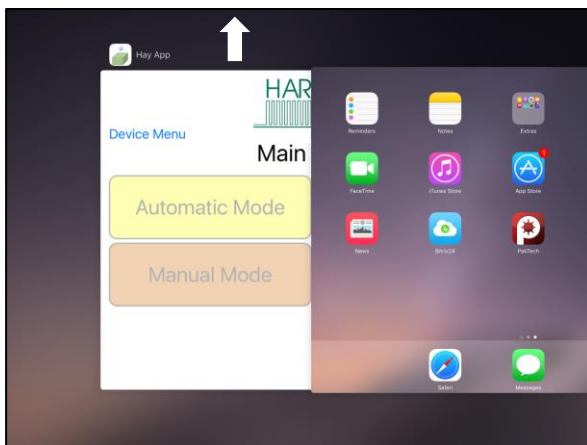

Figure B

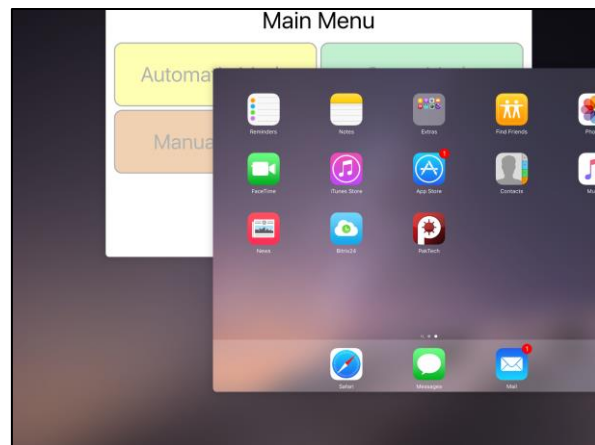

Figure C

Operating the Harvest Tec iPad App

After installation of the Bluetooth Receiver (030-6672A) on to the applicator system, attach the power cord 006-3650T to supply power.

*Refer to the applicator installation manual for details on connecting the Bluetooth Receiver.

When ready to operate your applicator system, open the Hay App on the iPad by selecting the Hay App icon.

Device Selection

The app will open to the Device Menu screen as shown below. Applicators which are equipped with the Bluetooth receiver that are within range (20') of the iPad and have power going to them, will be shown under the Active Connections section.

After the iPad connects to the Bluetooth receiver, select the applicator you want to connect with.

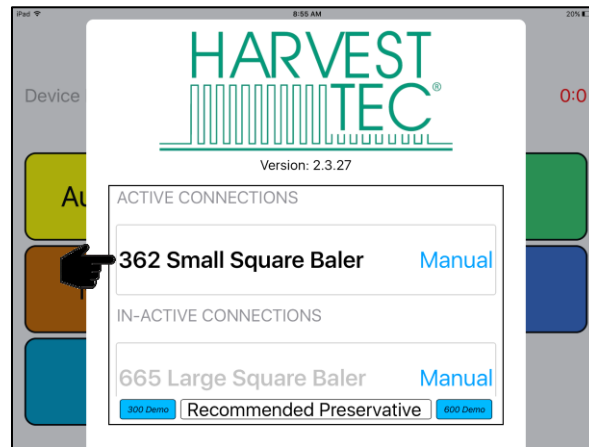

The In-Active Connections section will show applicator systems that have been connected in the past, but are not within range of the iPad or do not currently have power going to them (bottom left).

To remove a baler from the In-Active list, slide the bar displaying the baler name to the left, and select the Delete button that will appear (bottom right).

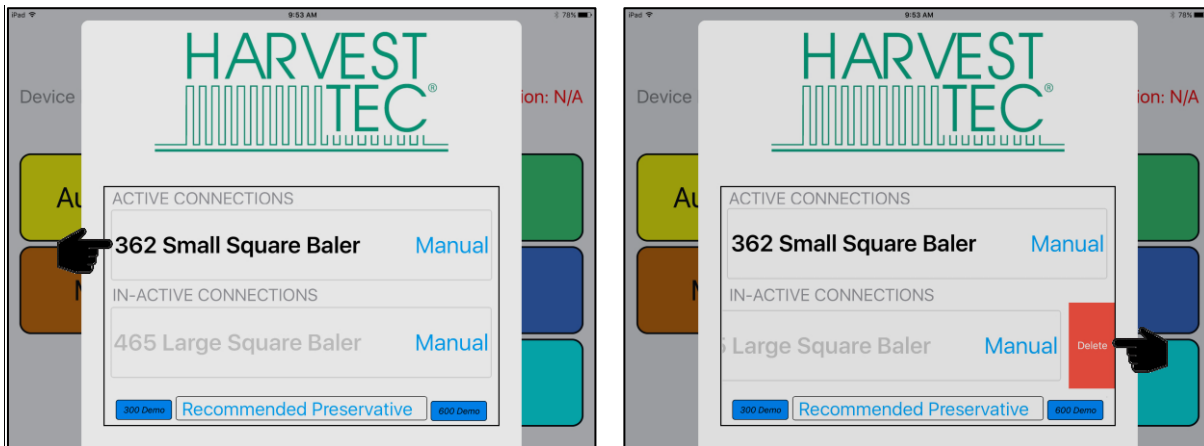

Operating the Harvest Tec iPad App (continued)

Demo Mode

Selecting the 300 Demo or 600 Demo button (below) will allow you to view the different screens of the applicator without requiring connection to an applicator system.

*This function is intended to be used as a visual aid, no values will be displayed.

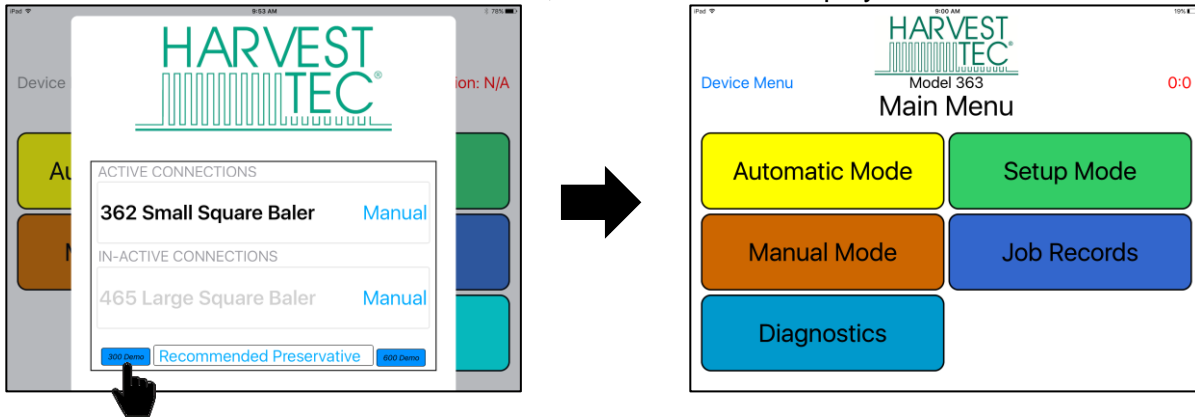

Manual Selection

Selecting the Manual button (below) displayed to the right of the baler name will open the operation manual for your baler.

*You do not need to be connected to a baler to open the manual and recommended preservative tabs after a baler has been connected.

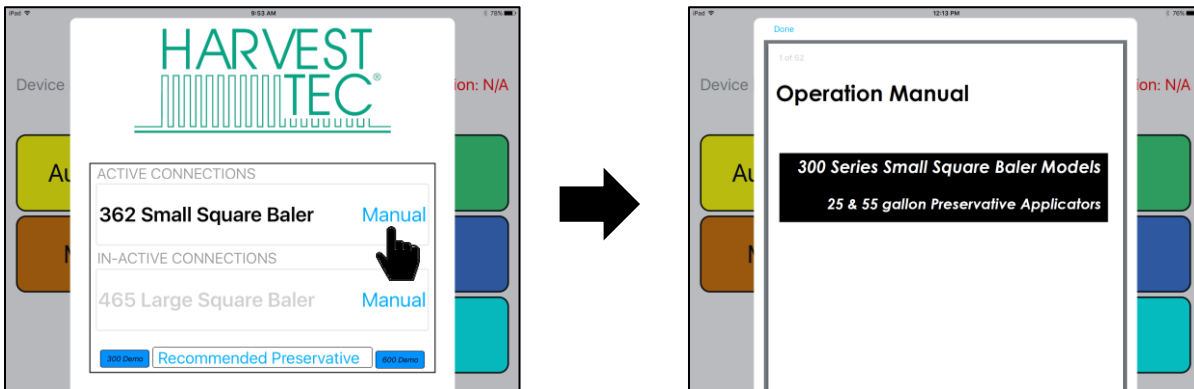

Recommended Preservative

To view recommended preservative information, application rates, and frequently asked preservative questions, select Recommended Preservative (below).

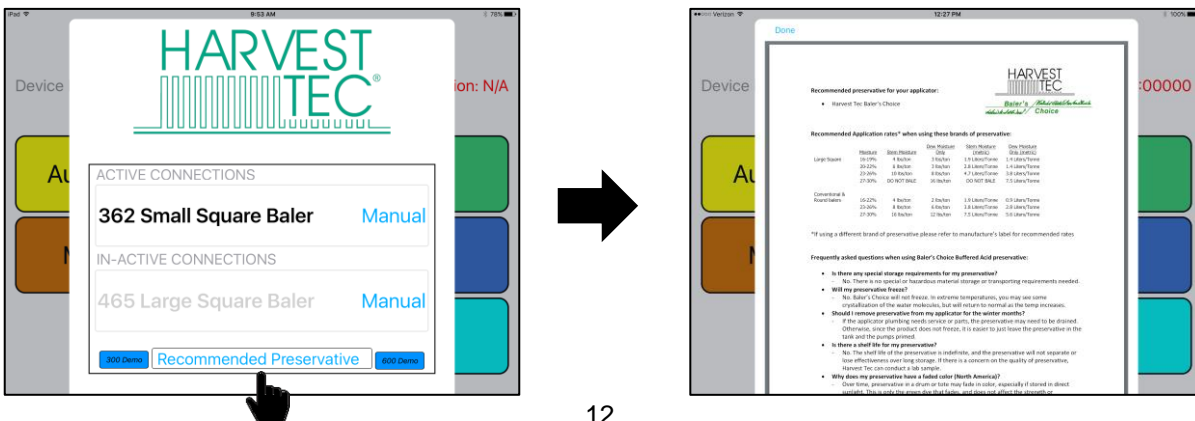

Operating the Harvest Tec iPad App (continued)

Once you have selected the baler you want to connect with from the Device Menu, the applicator main menu will display (below).

Ensure the iPad Bluetooth function is turned on in the Settings App.

*The applicator system will not appear under the Bluetooth Devices in the Settings App upon initial connection. You must open the Hay App to view the available devices by selecting the Device Menu. After you have connected through the Hay App, the system will then appear under the Bluetooth Devices in the Settings App.

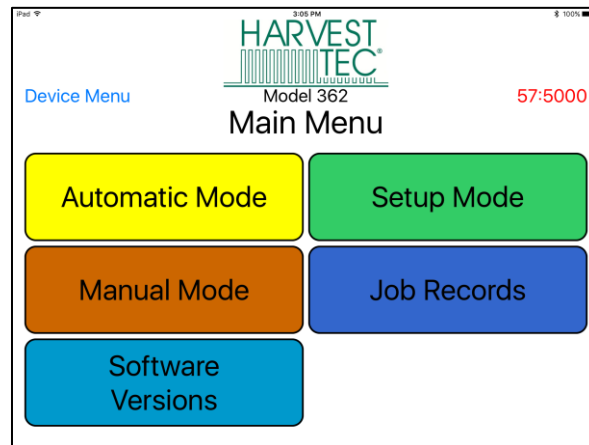

Tab Descriptions

Automatic Mode: This mode allows you to use all of the applicator features such as adjusting preservative application on the go and counting total pounds of product used.

Manual Mode: Allows operator to manually turn pump on and off. This mode also has moisture content displayed. Use this mode to prime pump.

Software Versions: This will allow you to view the current software versions running on the applicator.

Setup Mode: This mode allows the operator to adjust bale rate, application rate settings and select tip output.

Job Records: Keep track of up to 300 jobs with total product used, average moisture content, tons baled, and baling date.

Device Menu: This button will take you back to the Device Menu to select an applicator to connect with.

Screen Menus

Use the screen shots below to navigate through the operation screens.

Automatic Mode

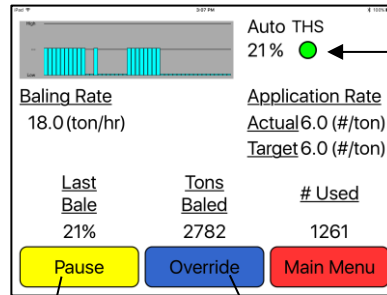
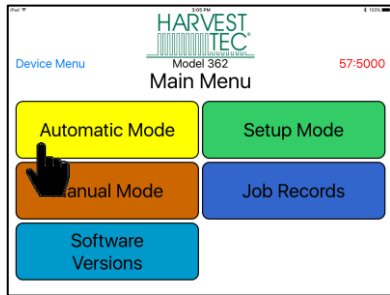

Bluetooth Connection Indicator
Green -iPad is connected
Yellow -iPad connecting
Red -iPad not connected

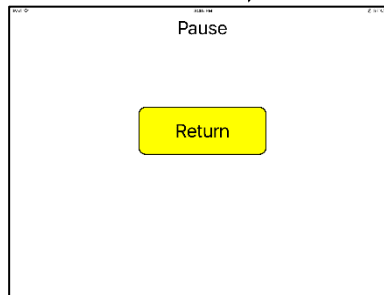

Manual Mode

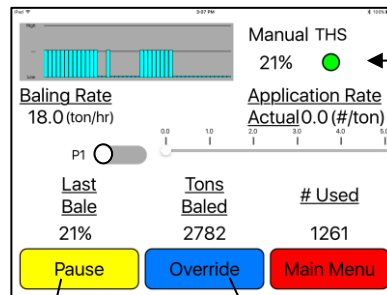
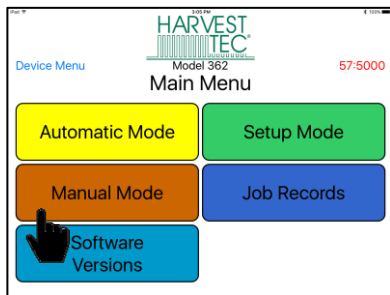

Bluetooth Connection Indicator
Green -iPad is connected
Yellow -iPad connecting
Red -iPad not connected

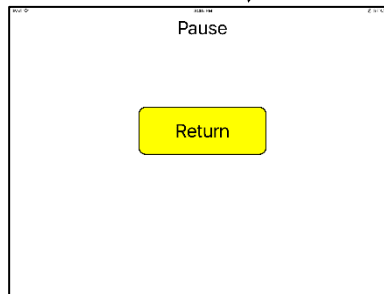

Operation Note:

Pressing the Home Button on the iPad **WILL NOT** stop application of the Harvest Tec System (see below):

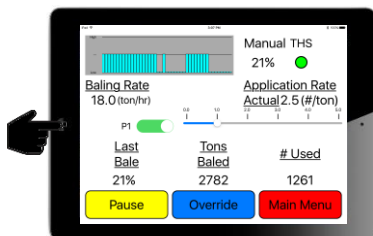

Select Pause or Main Menu to stop application

*To close app see the Shutting Down Hay App Section

Setup Mode

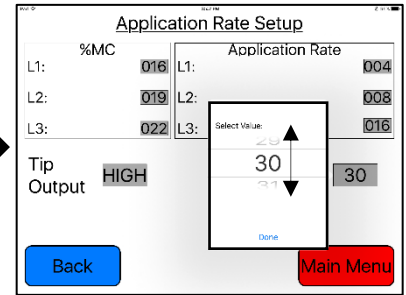
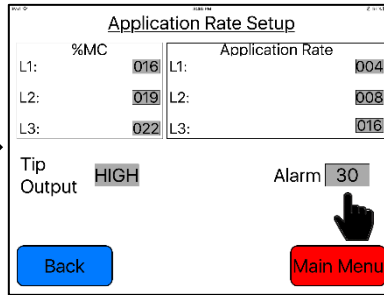
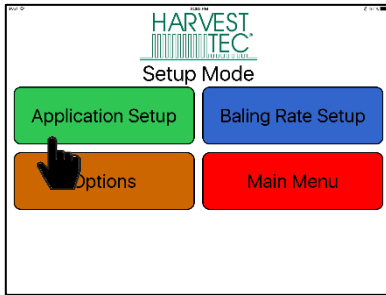
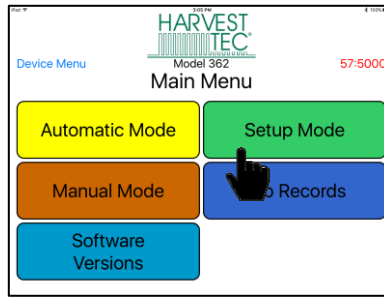

*All values can be changed

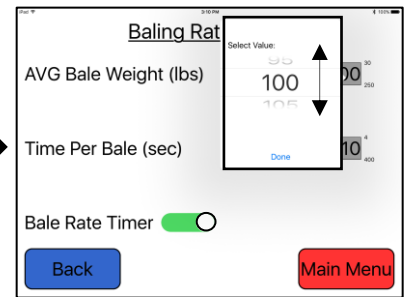
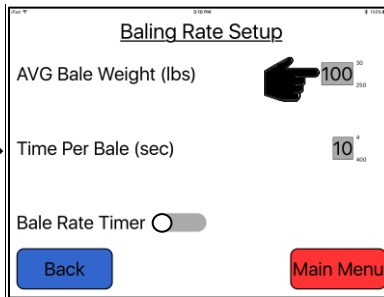
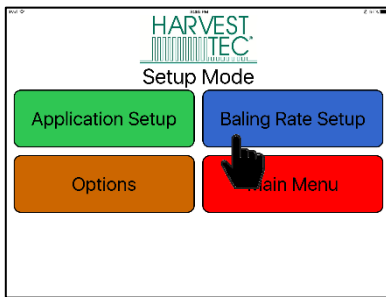

*All values can be changed

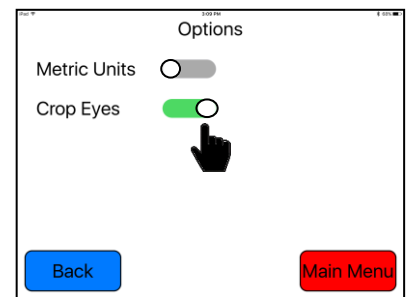
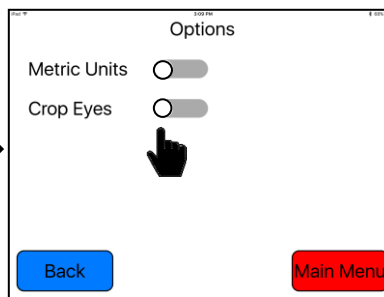
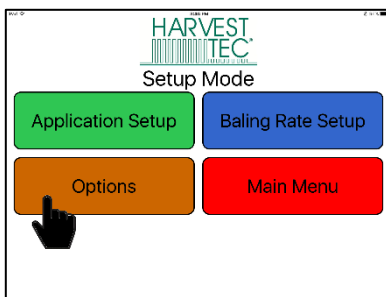

Slide option to right to turn On

Job Records

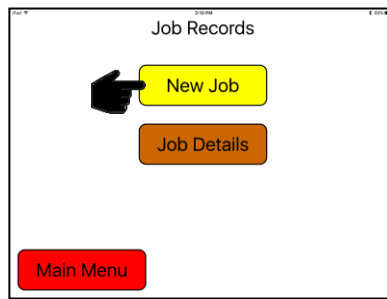
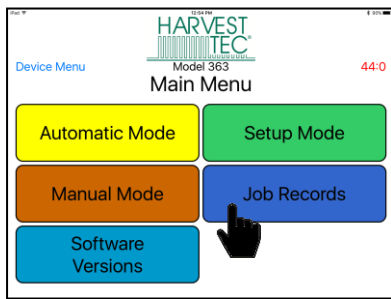

Select New Job to create a new job record



Type in Field Name and press Create Job

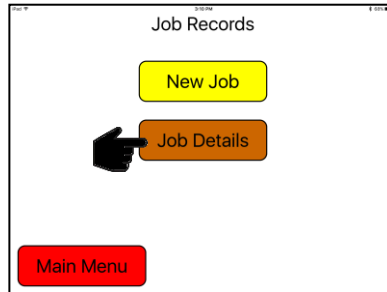
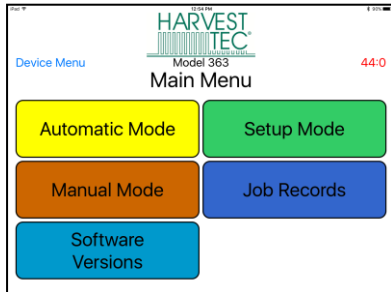

Select Job Details to view job records

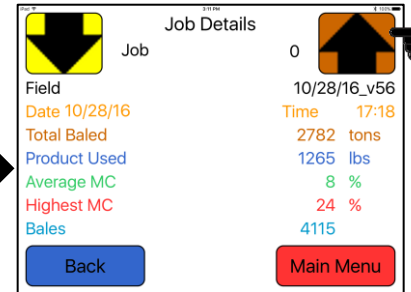

Select the Up and Down arrows to view different jobs

Software Versions

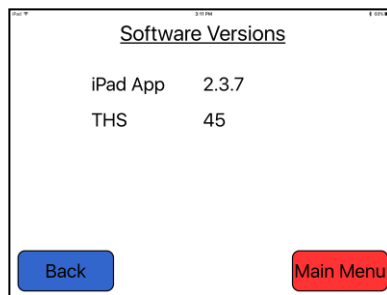
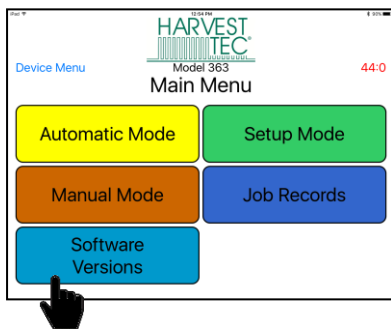

*This is an Example,
Software Versions will change

First Time and Annual Startup Instructions

THE UNIT MUST BE CHECKED OUT BEFORE FIELD OPERATION!

Check and Prime the Pumps

1. Put 10 gal (5L) of water or preservative in tank and turn main ball valve on.
2. Inspect for any leaks or drips at this time. If any are found tighten or replace area or fitting.
3. Turn controller on.
4. Press the SETUP MODE key. Turn the AVG Bale weight to 100 lbs (45kg), and Time Per Bale to 10 seconds and turn off the bale rate timer. Press the MAIN MENU key to return to the opening screen.
5. Press the MANUAL MODE key and the screen shown below will appear.

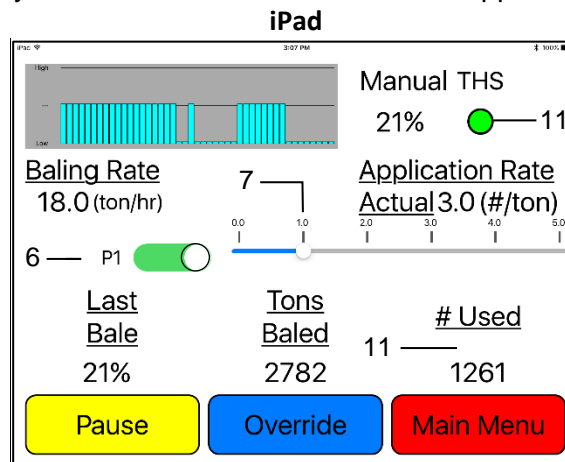

***Note: The system comes with the high tips already installed on the spray shield. Test the system with the tips you will use most often.**

6. Turn the pump on (P1). To turn the pump on slide the button next to P1 to the right. This will turn the bar next to P1 green, indicating the pump is on.
7. Set the pump output to setting 1.0.
8. Move the pump output settings to 2.0, 3.0, 4.0 and 5.0. With the baling rate set at 18 tons/hr, the application rate actual reading should be:

Testing Liquid	Tips	Level 1.0 #/Ton (L)	Level 2.0 #/Ton (L)	Level 3.0 #/Ton (L)	Level 4.0 #/Ton (L)	Level 5.0 #/Ton (L)
Water	Low	2.8-3.3 (1.2-1.4)	3.6-4.2 (1.5-1.8)	4.6-5.4 (2.0-2.3)	5.8-6.8 (2.5-2.9)	8.2-9.7 (3.5-4.1)
Water	High	3.4-4.0 (1.5-1.7)	6.1-7.1 (2.6-3.1)	9.5-11.2 (4.1-4.8)	14.6-17.2 (6.3-7.4)	17.7-20.8 (7.6-8.9)
Preservative	Low	1.4-1.6 (.6-.7)	2.7-3.1 (1.1-1.3)	3.8-4.5 (1.6-1.9)	5.1-6.0 (2.2-2.6)	6.4-7.5 (2.7-3.2)
Preservative	High	1.9-2.3 (.8-1.0)	4.7-5.5 (2.0-2.4)	8.4-9.8 (3.6-4.2)	13.3-15.6 (5.7-6.7)	18.1-21.3 (7.8-9.1)

9. This process will also be used to prime the pump whenever needed.
10. While running pump check for a good spray pattern out of the respective tips and verify that no parts of the system are leaking.
11. While doing these tests the Volume Used on the bottom of the screen will be increasing, this verifies that the flow meter is functioning.
12. The THS (Three Hundred Series) button displays your connection signal with the Bluetooth receiver. Green – THS is connected, Yellow – THS is connecting, Red – THS not connected.
13. Press main menu to return to the initial startup screen. Go to Setup Mode, select Baling Rate Setup and reset your Avg Bale Weight, the time per bale and turn the Bale Rate Timer on.

Setting Up the System for initial use with the iPad

In this mode you will setup your initial application rate and baling rate.

Application Rate

After pushing the SETUP MODE key in the Main Menu screen, the top left screen will appear:

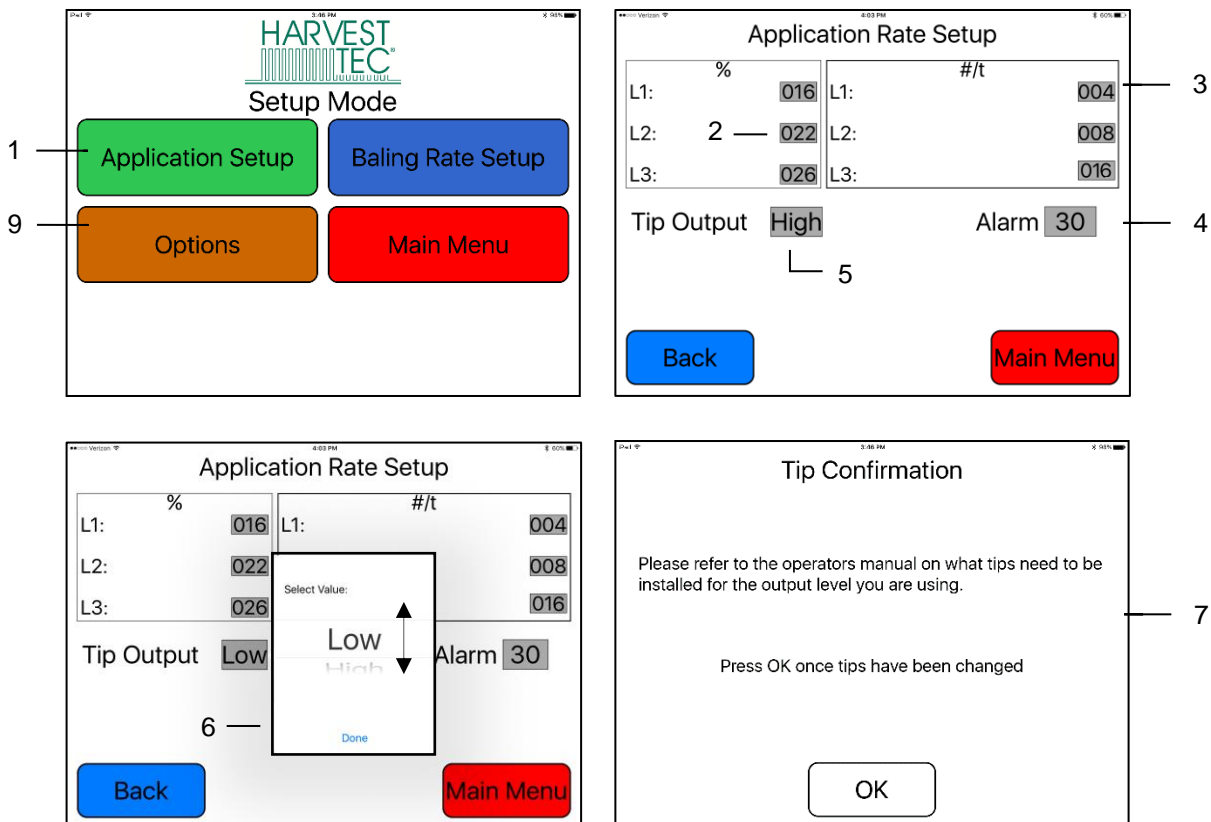

1. On the Setup Mode screen press the APPLICATION RATE key. Once selected the SETUP APPLICATION RATE screen will be shown. (Top right picture)
2. Press any of the grey number values to the right of %MC to adjust their figures. The scroll pad shown on the bottom left will display. Remember level 1 must be lower than level 2 and level 2 must be lower than level 3. Press Done, when value has been selected. Harvest Tec products recommend set points of 16, 22, and 26 % MC levels. These are preset from the factory. Press Back to return.
3. To change rate of chemical application, press any of the grey number values to the right of RATE. Remember level 1 must be lower than level 2 and level 2 must be lower than level 3. Press Done, when value has been selected. Harvest Tec products recommend rates of 4, 8, and 16 lbs/ton (2,3,8 L/MT). These rates are preset from the factory. Press Back to return to previous screen. **IT IS THE OPERATORS RESPONSIBILITY TO FOLLOW THE RECOMMENDATIONS OF THE PRESERVATIVE. ONLY THE OPERATOR CAN APPLY THE PROPER RATE.**
4. To set the alarm, press the grey number value and set the level at which you want the alarm to activate. To turn the alarm off, set level above 50.
5. Press the grey area next to Tip Output to **cycle between the high and low sets of tips**. Use the correct tip set for the field conditions.
6. The menu will appear to choose between Low and High Output tips. Based on 4, 8, 16 #/Ton application rates, select the one that best represents your ton/hr rate: Low 3-7 Ton/hr, High 4-25 Ton/hr.
7. The tip confirmation screen will appear. Press OK once tips are changed.
8. Next press the BACK key found on the bottom left hand figure of the screen to return to SETUP MODE screen or press MAIN MENU key on bottom right hand figure of the screen to return to opening screen.
9. Press OPTIONS to adjust the unit between metric and standard units.

Baling Rate Settings – Small Square Balers

After pushing the SETUP MODE key in the Main Menu screen, the screen on the left will appear:

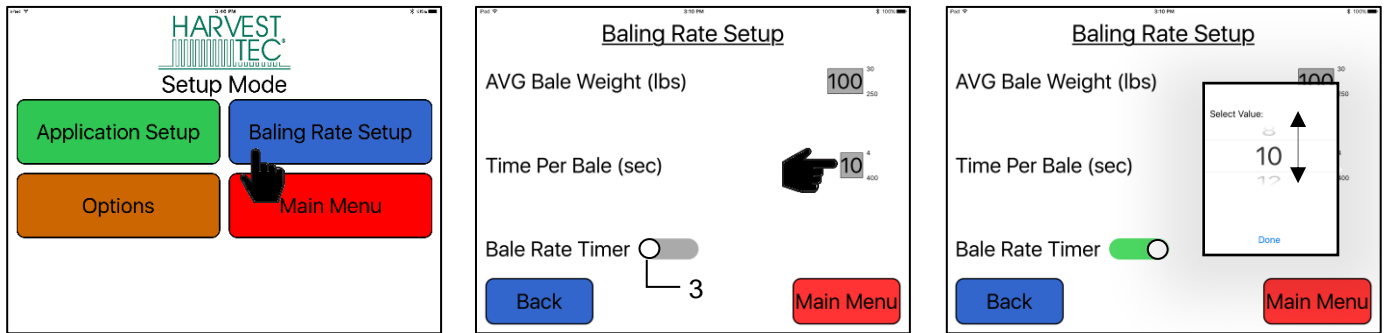

1. On the setup mode screen press the BALING RATE SETUP key.
2. Press the grey number value to the right of AVG Bale Weight (Lbs). To adjust the weight of your bales, the scroll tool shown on the right will display. Scroll through the values to select correct information, press DONE when value has been selected. The information will be saved until updated. Use the same procedure for adjusting time per bale.
3. Small square balers are equipped with a Bale Rate Timer which can be turned ON by sliding the bar to the right as shown above. A green bar indicates that the bale rate sensors are on. While a grey bar means the bale rate sensors are off.
Note: Bale rate sensors are used instead of a fixed time per bale to help determine a real time ton per hour reading.
4. Press the BACK key found on the bottom left hand figure of the screen to return to SETUP MODE screen or press the MAIN MENU key to return to the opening screen.

Operation Instructions

Automatic mode will automatically apply product based on hay moisture content sensed by the moisture sensors and the operator's presets. See SETTING UP SYSTEM FOR INITIAL USE to change any settings.

Automatic Mode

After pushing the AUTOMATIC MODE key in the Main Menu screen, the following screen will appear:

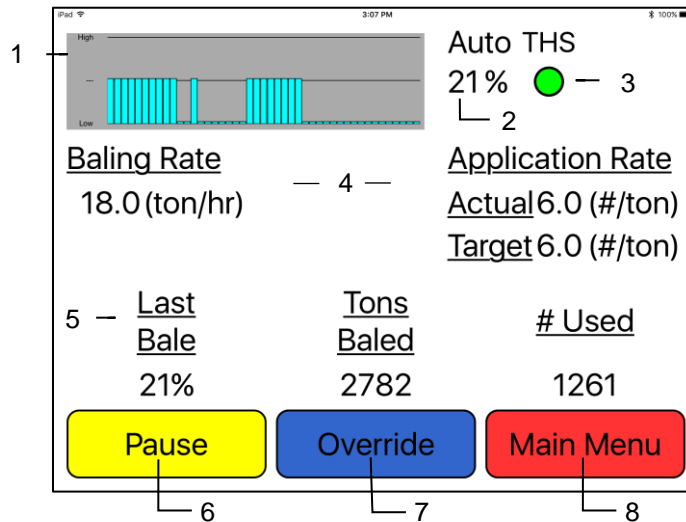

1. The graph shows the moisture trend from the past 90 seconds in 3 second intervals.
2. The moisture content is shown in the upper right hand corner.
3. The THS (Three Hundred Series) button displays your connection signal with the Bluetooth receiver. Green – THS is connected, Yellow – THS is connecting, Red – THS not connected.
4. Baling Rate and Application Rate are shown in the middle of the screen. The operator sets the target application rate and baling rate in the setup mode; the actual rate should be within +/- one pound.
5. Last Bale Moisture, Tons Baled, and # Used (pounds used) will show at the bottom of the screen. These numbers will only reset once a new job record is created. **NOTE: Initial start-up requires pressing the New Job key in the Job Records screen in order for Volume Used accumulation to be recorded. This only needs to be done once on initial start-up of system and not every time.** (See JOB RECORDS screen)
6. To pause the unit while in operation select the Pause key.
7. Push the OVERRIDE key to turn the pump for full output of the system. Use this mode when going through a short area of wet crop.
8. Press the MAIN MENU key to return to the opening screen.

Manual Mode

After pushing the MANUAL MODE key in the Main Menu screen, the following screen will appear: **Manual mode will apply preservative to the hay at a fixed rate regardless of the moisture.**

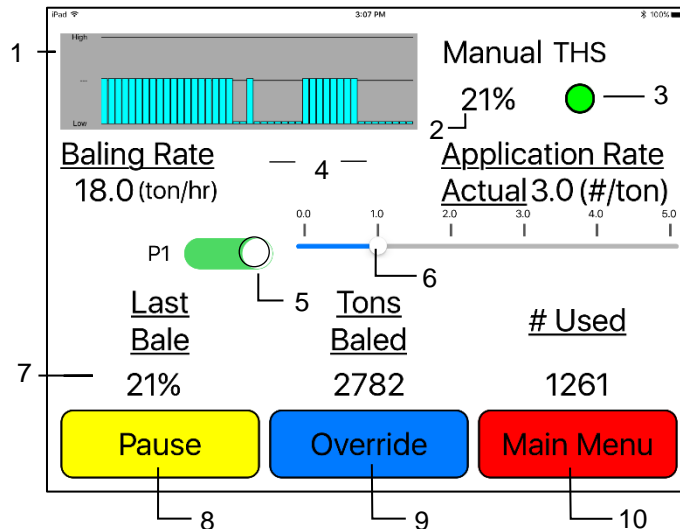

1. This graph shows the moisture trend from the last 90 seconds of baling (one every 3 seconds).
2. The moisture content is shown in the upper right hand corner.
3. The THS (Three Hundred Series) button displays your connection signal with the Bluetooth receiver. Green – THS is connected, Yellow – THS is connecting, Red – THS not connected. Pressing MAIN MENU key to return to the initial startup screen.
4. Baling rate and Application rate are shown in the middle of the screen.
5. To turn the pump on, by moving the slider next to P1, so it shows green. In Manual Mode (regardless of moisture, baling rate or bale weight) the outputs are fixed rates.
6. Slide the pump output button from level 1.0 → 5.0 to increase the amount of preservative being applied. The application rates are shown below. Pump outputs are considered normal when they are within +/- 8%.

Testing Liquid	Tips	Level 1.0 Lbs/HR (L)	Level 2.0 Lbs/HR (L)	Level 3.0 Lbs/HR (L)	Level 4.0 Lbs/HR (L)	Level 5.0 Lbs/HR (L)
Water	Low	50.9-59.8 (21.8-25.6)	65.0-76.3 (27.9-32.7)	82.2-96.5 (35.2-41.4)	104.6-122.8 (44.8-52.6)	148.1-173.9 (63.5-74.5)
Water	High	61.6-72.4 (26.4-31.0)	109.2-128.2 (46.8-54.9)	171.4-201.2 (73.5-86.3)	263.4-309.2 (112.9-132.6)	318.9-374.4 (136.7-160.5)
Preservative	Low	24.8-29.2 (10.6-12.5)	47.8-56.2 (20.5-24.1)	69.0-81.0 (29.6-34.7)	92.0-108.0 (39.4-46.3)	115.0-135.0 (49.3-57.9)
Preservative	High	35.0-41.0 (15.0-17.6)	84.6-99.4 (36.3-42.6)	150.9-177.1 (64.7-75.9)	239.2-280.8 (102.5-120.4)	326.6-383.4 (140.0-164.3)

7. Last Bale Moisture, Tons Baled, and # Used (pounds used) will show at the bottom of the screen. These numbers will reset once a new job record is created **NOTE: Initial start-up requires pressing the New Job key in the Job Records screen in order for Volume Used accumulation to be recorded. This only needs to be done once on initial start-up of system and not every time.** (See JOB RECORDS screen)
8. To pause the unit during operation select the Pause key.
9. Push the OVERRIDE key to turn on the pump for full output of the system. Use this mode when going through a short area of wet crop.
10. Pressing MAIN MENU will return you to the opening screen.

Job Records

After pushing the JOB RECORDS key in the Main Menu screen, the following screen will appear:



1. Select the New Job tab when creating a new job record.
2. Type in the desired field name and press Create Job
3. The job details screen will appear with name of the job shown under the up arrow. Information shown on this screen will include Date, Total Baled (tons baled), Product Used, Average Moisture Content, Highest Moisture Content and Bales.
4. Every time the NEW JOB key is pressed the accumulated pounds on auto and manual modes will be reset to zero. After 300 jobs have been stored, the next time the NEW JOB key is pressed the system will start over with job one and the old job will be replaced.
5. To return the opening screen, press the MAIN MENU key. NOTE: Initial start-up requires pressing the New Job key in the Job Records screen in order for Volume Used accumulation to be recorded. This only needs to be done once on initial start-up of system and not every time the system is started for operation.

Software Versions

After pushing the Software Versions key in the Main Menu screen, the following screen will appear:

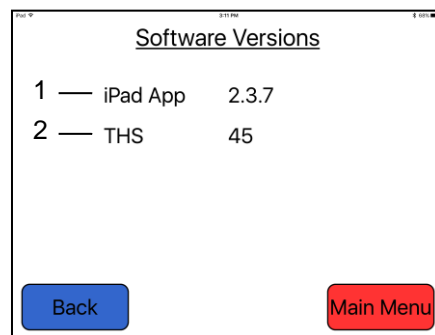

*This is an example,
Software Versions will change

1. The first line will show the current version of the Hay App being used on the iPad.
Note: When an update is available, your iPad will prompt you when connected to the internet
2. The second line will show the current version of software being used on the Three Hundred Series (THS) applicator system.

Note: Any software updates that are available will be shown at: harvesttec.com/product-updates/

Bluetooth Receiver Lights

New for production year 2018. All Bluetooth receivers (030-6672A) are now equipped with lights to indicate both power and Hay App connection on the Apple iPad. Clean light regularly

Blinking Lights – System is waiting for the processor to connect, which could take up to 35 seconds.

Red Light – The Bluetooth receiver has power

Green Light – The Bluetooth receiver is connected to the Hay App.



Maintenance

If you are unsure how to perform any of the maintenance steps have your local authorized dealer perform the tasks.

Maintenance Schedule

	Daily	10 hrs	400 hrs	Weekly	Monthly	Season
Diagnostics	X					X
Filter bowl cleaning		X				X
Tips & tip screen cleaning		X				X
Tank lid cleaning		X				X
Dielectric grease connections					X	X
Rebuild pump			X			
Battery connections				X		X
Check valves			X			
Visually inspect hoses				X		X

Filter bowl cleaning: The filter bowl is located in front of the applicators tank and is connected to the ball valve. Before cleaning the filter bowl all personal protective equipment must be worn (Face shield or goggles, chemically resistant apron, boots, and gloves).

Verify that the ball valve located next to the pump is turned off. Locate the filter bowl on the side of the pump manifold (A). Unscrew the bottom section of the filter bowl and remove the strainer (B). Clean off any debris and soak in warm water with a mild soap if necessary. Once the screen is clean reinstall by following the directions in reverse.



A



B

Maintenance (continued)

Tips & tip screen cleaning: Before cleaning the tips and screens all personal protective equipment must be worn (Face shield or goggles, chemically resistant apron, boots, and gloves).

Verify that the ball valve located next to the pump is turned off. Disconnect spray shield from hangers if possible or remove tips in place. Remove the tip, and screen if equipped. Some models may require a wrench to remove. Clean off any debris and soak tip and screen in warm water with a mild soap if necessary. Once the tips and screens are cleaned reinstall by following the directions in reverse.

Tank lid cleaning: Before cleaning the tank lid all personal protective equipment must be worn (Face shield or goggles, chemically resistant apron, boots, and gloves).

The tank lid is located on the top of the tank. Unscrew the tank lid and bring down ground level. Use compressed air clean out the tank screen (D). If the screen cannot be thoroughly cleaned with compressed air, replace fitting (005-9022B3). Once the screen is cleaned reinstall the cover.

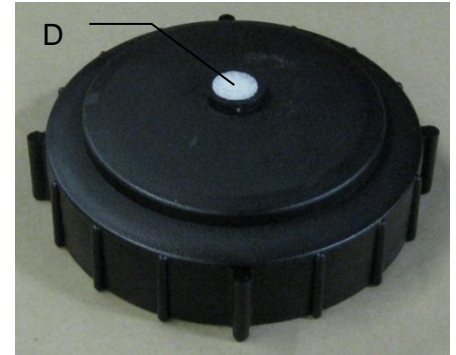

Dielectric grease connections: Disconnect all harnesses on the applicator, clean the connections, and repack with dielectric grease.

Rebuild pump: If Manual mode show that the pump is running lower than normal, a pump rebuild may be necessary. To do this rebuild the pump must be removed from the pump manifold. Pump rebuild is part no. 007-4581. A service pack that includes pump rebuilds and check valves is available from your local dealer.

Verify that the ball valve is turned off. Before working around the pumps all personal protective equipment must be worn (Face shield or goggles, chemically resistant apron, boots, and gloves). Remove pump from manifold. Follow rebuild instructions supplied with pump rebuild kit. Reinstall after rebuild is complete.

Battery connections: Follow the batteries safety warnings and clean the battery connections. If the connections cannot be cleaned, replace harness.

Solenoid Valves: Before servicing the solenoid all personal protective equipment must be worn (Face shield or goggles, chemically resistant apron, boots, and gloves), inlet side of solenoid could be under pressure Clean the solenoid valve body (004-1207VF).

Verify the ball valve is turned off before service the solenoid. Replace the solenoid if needed (002-2203F).

Miscellaneous maintenance:

1. Depending on the product being used, the system may need to be flushed with water at a regular interval (consult with manufacturer of the chemical.) If Harvest Tec product is being used, flushing is not necessary.
2. Although the pump can run dry, extended operation of a dry pump will increase wear. Watch the preservative level in the tank.
3. If you are using bacterial inoculants, flush your system daily after every use.

Winter Storage

1. Thoroughly flush the system with water.
2. Remove the filter bowl and run dry until the water has cleared out of the intake side.
3. Drain all lines on the outlet side.
4. Never use oils or alcohol based anti-freeze in the system.
5. For spring start-up, if the pump is frozen, turn off the power immediately to avoid burning the motor or damaging the circuit board. The pump head can be disassembled and freed or rebuilt in most cases
6. Disconnect power from the Three Hundred Series (THS) control Box.
7. Remove display from tractor and store in a warm, dry place.

Wiring Diagram – 344, 345, 350, 351

1. Connect the power harness (006-3650T) to the tractor battery (12 volt) using the red wire with fuse to the positive side and the black wire to the negative.



- A. The power harness must be connected to the battery!** The unit will draw more amps than convenience outlets can handle. Any modifications of the power harness will void systems warranty. **CONTACT HARVEST TEC BEFORE MODIFICATIONS.**
- B. This unit will not function on positive ground tractors.**
- C. If the unit loses power while operating it will not keep track of accumulated pounds of product used.**

2. The power harness on the tractor (006-3650T) will run from the tractor battery to the hitch. The power harness on the baler (006-3650B1) will connect to the tractor power harness (006-3650T) at the hitch.
3. Connect the keyed power wire (006-5650K) to a keyed power source on the tractor. **The keyed power wire must connect to a keyed source or the unit will not power up correctly.**
4. Attached the Bluetooth Receiver (030-6672B) to the tractor power harness (006-3650T). Mount the Bluetooth receiver in a safe location as close to iPad as possible in cab.
5. Attach the End of Bale (EOB) connection on the controller to the End of Bale Sensor (006-7400).
6. Attach the Solenoid (V1) (Delphi connector) connection on the controller to the wire from the solenoid (002-2203F). Note: If solenoid is connected to V2-DSM (not used) connection, solenoid will not work.
7. Attach the Flowmeter (FLOW) connection on the controller to the flowmeter (006-4729A).
 - A. Attach the spade connectors on the FLOW harness to the Pump (007-4120DE).

System wiring diagram

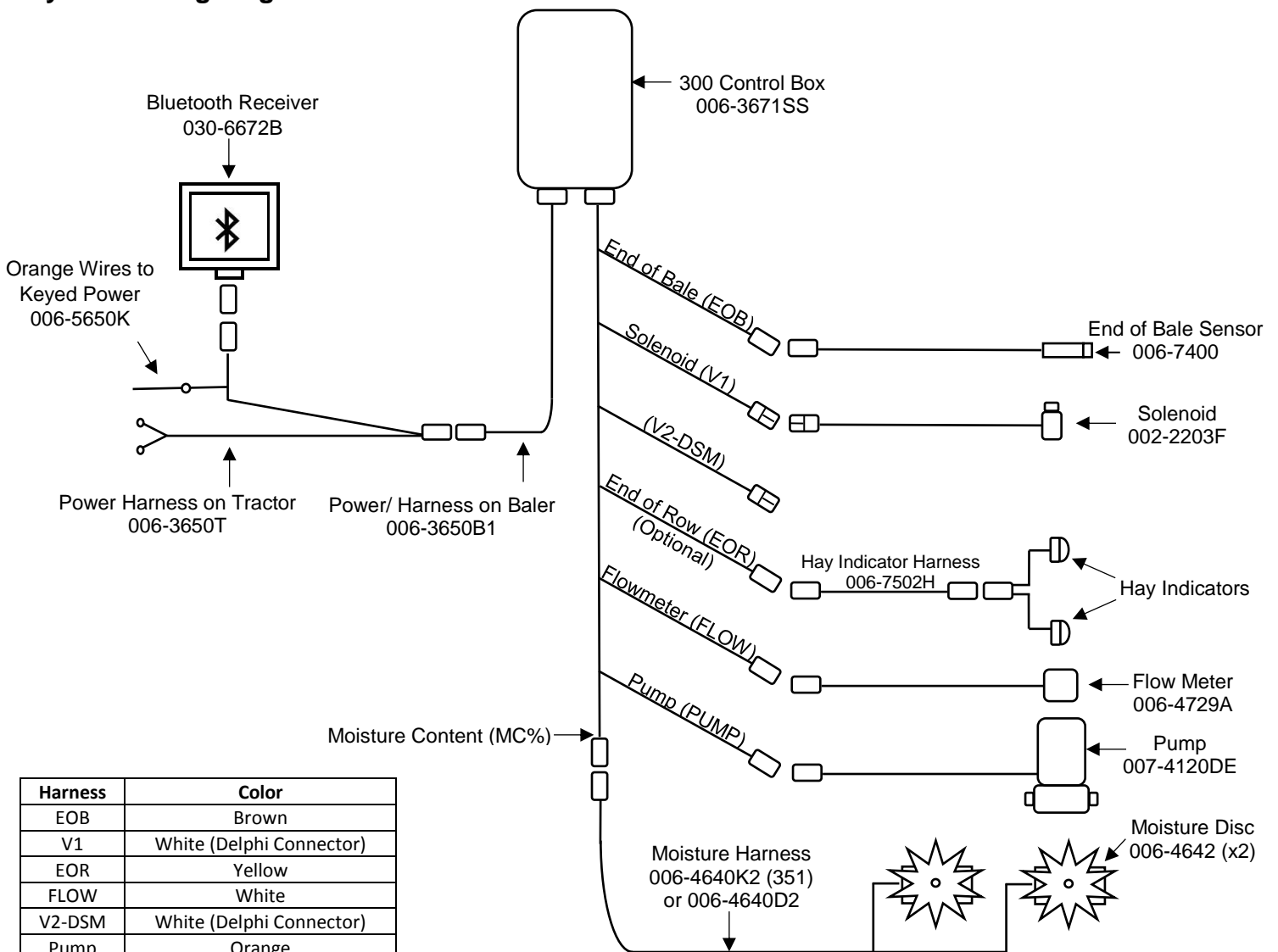

Harness	Color
EOB	Brown
V1	White (Delphi Connector)
EOR	Yellow
FLOW	White
V2-DSM	White (Delphi Connector)
Pump	Orange

Common Questions

1. **How do I turn the system on/off?**

To turn the system ON open the Hay App, then select the active system for the baler you are using.

To turn the system OFF click the Main Menu screen. To close the app double click the home button on the iPad and swipe the app that you would like closed, toward the top of the screen until it is no longer visible. See SHUTTING DOWN THE HAY APP for more details.

2. **How to get in the LBS/TON, MC%, and TONS/HR screens?**

In the Main Menu press the SETUP MODE key. From this screen you can change your application rates and how much product is applied. See SETTING UP FOR INITIAL USE for a detailed explanation of this process.

3. **The unit is stuck in the Application Rate screen.**

In the Application Rate screen, level 1 must be less than level 2, and level 2 must be less than level 3. For example, if level 1 is set at 16, level 2 must be set at 17 or higher, and level 3 must be set higher than level 2.

4. **How does OVERRIDE work?**

Override turns on the pump and opens the solenoid for full output. The pump and solenoid will remain at full output until the operator turns the pump off by pressing the OVERRIDE key again.

5. **The flow meter reading is more or less than the programmed level set in the box.**

Some variation in flow meter readings compared to the programmed set point is normal due to factory tolerances on the pump motor as well as varying tractor voltages inputted to the control box. The flow meter reading is an accurate measure of how much product is actually being applied. The set points then will need to be adjusted if you want to attain a different flow meter reading.

6. **The moisture content displays “LO” or “HI” all the time.**

When the moisture content display does not change frequently while baling, there is likely a faulty star wheel connection. Initially check inside the white star wheel block, to see if the electronic swivel is in the star wheel shaft and that the star wheel shaft is not coming out of the block. Also, check all star wheel wires and connectors to see if there is a continuity of grounding problem.

7. **Should the battery connections be removed before jump starting or charging a battery?**

Yes. Anytime the tractor will have voltage going up rapidly the connections should be removed.

8. **What is the expected battery life of the iPad when baling?**

3.5 hours is the expected amount of time for the battery when continuously baling. Shut off all other applications, wireless internet, and Wi-Fi signal to reduce the amount of programs iPad is running. It is recommended to use an accessory outlet charger when operating (not included with iPad).

*Note: Not all chargers are designed to charge an iPad, verify before purchasing.

9. **What is the max distance for connection between the iPad and the Bluetooth Receiver?**

The range for the connection will depend on the amount of equipment (tractor, baler, ect.) between the two devices. The max distance will range between 10' – 20'.

10. **What do the lights on the 030-6672B indicate?**

Red Light – The Bluetooth receiver has power. *Green Light* – When the proper active connection is selected in the Hay App menu, the green light will indicate connection with the iPad.

Troubleshooting

Problem	Possible cause(s)	Solution(s)
Pump will not run.	1. No voltage to THS.	1. Check for short, low voltage, and replace fuse if necessary.
	2. Pump locked up.	2. Clean or rebuild pump if motor ok
	3. Damaged wire.	3. Repair damaged wire.
	4. Damaged solenoid	4. Replace / Clean
Pump runs but will not prime.	1. Air leak in intake.	1. Tighten fittings on intake side.
	2. Clogged intake.	2. Clean.
	3. Restricted outlet.	3. Check and clean tips.
	4. Check valve stuck closed.	4. Clean or repair check valve.
	5. Dirt inside pump.	5. Replace pump check valve.
Pump does not develop enough output.	1. Air leaks or clogs on inlet.	1. Tighten or clean filter bowl
	2. Pump worn or dirty.	2. Rebuild pump.
Moisture reading errors (reading high or low)	1. Wire disconnected or bad connection between star wheels and THS	1. Reconnect wire.
	2. Low power supply to THS	2. Check voltage at box. Min of 12V
	3. Hay over 32% moisture	
	4. Ground contact with one or both star wheels and THS	4. Reconnect.
	5. Short in wire between star wheels and THS	5. Replace wire.
Moisture Reading Erratic	1. Check all wiring connections for corrosion or poor contact.	1. Apply dielectric grease to all connections.
	2. Check power supply at tractor. Voltage should be constant between 12V-14V	2. Install voltage surge protection on tractors alternator.
Product is less than actual product used.	1. Voltage supplied to flow meter is less than 11 volts.	1. Check for a min of 11 volts supplied at THS.
	2. Wiring short in signal to baler mounted processor.	2. Inspect wire and replace if necessary.
	3. Using product other than Harvest Tec	3. Catch and weigh product to check outputs.
Product shown is 10% different than actual product used.	1. High voltage supplied to the meter.	1. Check voltage at THS. Max of 18 volts.
	2. Air leak in intake.	2. Look for air bubbles in line. Replace line or other defective area that is allowing air into the system.
	3. Using product other than Harvest Tec	3. Catch and weigh product to check outputs.
System leaks product out of tips after shut down.	1. Dirty or defective solenoid	1. Clean or Replace.
System does not pause at the end of a row.	1. Short in cable.	1. Replace cable.
Solenoid will not pulse	1. Dirty or plugged solenoid 2. Damaged wire from control 3. Wire disconnected	1. Clean or Replace 2. Repair 3. Reattach
Bluetooth Receiver lights will not illuminate	1. Bluetooth receiver not connected 2. Harness disconnected 3. Low power	1. Check connections and voltage. Minimum 12.5V needed.
	<i>Red Light</i> – The Bluetooth receiver has power <i>Green Light</i> – When the proper active connection is selected in the Hay App menu, the green light will indicate connection with the iPad.	

iPad Troubleshooting

<u>iPad Symptom</u>	<u>Troubleshooting</u>
iPad won't turn on	-Turn your iPad off and on. Press and hold the Sleep/Wake button for a few seconds until a red slider appears; then slide it. Press and hold the Sleep/Wake button to turn on again.
	-Reset your iPad. Press the "Sleep/Wake" button and the "Home" button simultaneously for at least 10 seconds until the Apple logo appears on the screen. This reset will not damage your files.
	-Battery may be drained. Plug iPad into your computer or AC adapter and see if anything happens. The iPad will recognize it has been connected to a power source and charge its battery. If it will no longer charge, the battery must be swapped with a replacement battery. Battery level displays in top right corner of iPad.
Cannot get an active baler connection	-Make sure that your Bluetooth accessory and iOS device are close to each other when connecting.
	-Make sure that your Bluetooth accessory is on and fully charged or connected to power. If it uses batteries, test them to see if they need to be replaced.
	-Restart your Bluetooth receiver, by removing power and reconnecting after 30 seconds.
	-Make sure that you have at least a 3 rd generation iPad with iOS8 or greater operating system on your iPad
	-On your iPad, go to Settings > Bluetooth and make sure that Bluetooth is on. If you can't turn Bluetooth on or you see a spinning gear, restart your iPad
	-Unpair the Bluetooth accessory, put the accessory back in discovery mode, then pair and connect it again. By tapping on its name in the Bluetooth accessories tab and then Forget this Device. In settings, tap on a device's name, then Unpair.
	-Display connector plug and bale rate sensors plug are switched on THS. Switch connections.
	-Short in display cable. Replace the cable.
iPad touchscreen is slow or does not respond	-Screen may be dirty. Clean screen. Unplug everything, turn off iPad and with soft, lint-free, slightly damp cloth gently wipe screen. DO NOT use window cleaners and paper towels.
	-If you have a screen protector sheet, try removing it.
iPad is not charging or is slow to charge	-In order to charge your iPad you can try either connecting your iPad to a power outlet or connecting to a USB 2.0 port on a computer. However, note that computers generally don't supply enough power to their USB ports to be able to charge an iPad. When this happens, a "Not Charging" message will appear.
How can I unlock my iPad if I forgot the passcode	-If you cannot remember the passcode, you will need to restore your device using the computer with which you last synced. This allows you to reset your passcode and resync the data from the device (or restore from a backup). If you restore on a different computer that was never synced with the device, you will be able to unlock the device for use and remove the passcode, but your data will not be present.
How do I send in my iPad for service?	-Refer to your iPad owner's manual or contact Apple. DO NOT SEND iPad TO HARVEST TEC.
For other issues refer to your iPad Owner's Manual or contact Apple Directly	

Harvest Tec Does Not Service iPads

Pin Outs

Power Harness 006-3650T at Tractor Hitch

Pin 1	Red	+12V Power to BLE
Pin 2	Red	+12V Power to THS
Pin 3	Orange	Keyed Power
Pin 4	Not Used	
Pin 5	Green	HT Can Low
Pin 6	Yellow	HT Can Hi
Pin 7	Not Used	
Pin 8	Black	Ground from BLE
Pin 9	Black	Ground from THS
Pin 10	Not Used	



Power Harness 006-3650B1 at Baler Hitch

Pin 1	Red	+12V Power to BLE
Pin 2	Red	+12V Power to THS
Pin 3	Orange	Keyed Power
Pin 4	Not Used	
Pin 5	Green	HT Can Low
Pin 6	Yellow	HT Can Hi
Pin 7	Not Used	
Pin 8	Black	Ground from BLE
Pin 9	Black	Ground from THS
Pin 10	Not Used	



Bluetooth Receiver on Harness 006-3650T

Pin 1	Red	+12V Power for BLE
Pin 2	Black	Ground for BLE
Pin 3	Yellow	HT Can Low
Pin 4	Not Used	
Pin 5	Green	HT Can Hi
Pin 6	Not Used	
Pin 7	Not Used	



End of Bale Sensor at 300 Controller Harness

Pin 1	Brown	Sensor Power
Pin 2	Blue	Sensor Ground
Pin 3	N/A	
Pin 4	Black	Signal from Sensor

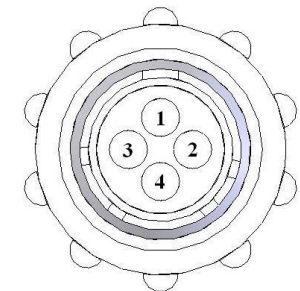

Flow Meter at 300 Controller Harness

Pin 1	White	+5-12V Power
Pin 2	Brown	Ground
Pin 3	Green	Signal
Pin 4	Not Used	

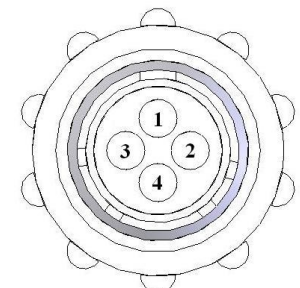

Pin Outs (continued)

End of Row Sensor at 300 Controller Harness

Pin 1	Red/White	+12V Power
Pin 2	Black/White	Ground
Pin 3	Yellow	Signal
Pin 4	N/A	

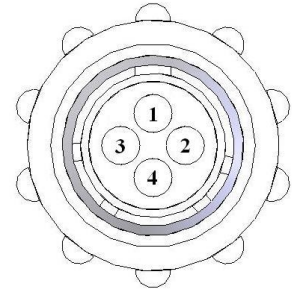

Moisture Sensor connection at 300 Controller Harness

Pin 1	Not Used	
Pin 2	Not Used	
Pin 3	Not Used	
Pin 4	Not Used	
Pin 5	Not Used	
Pin 6	Not Used	
Pin 7	Not Used	
Pin 8	Blue	Signal for Sensor 1
Pin 9	Blue	Signal for Sensor 2

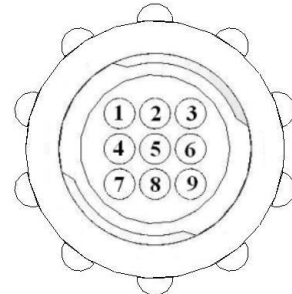

Pump connection at 300 Controller Harness

Pin 1	Red	Power to Pump
Pin 2	Black	Ground to Pump

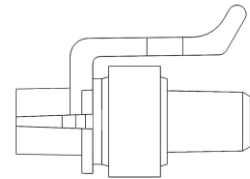
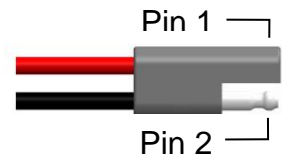

Solenoid Connection at 300 Controller Harness

Pin A	Black	Solenoid Pause
Pin B	White	Solenoid Ground

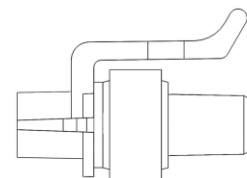
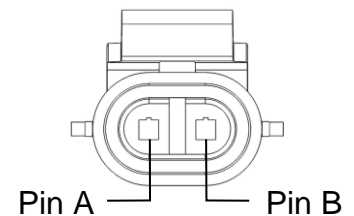

V2-DSM Connection at 300 Controller Harness

Pin A	Black	Solenoid Pause
Pin B	White	Solenoid Ground

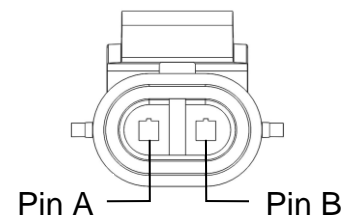

Parts Breakdown

Model 344 Base Kit

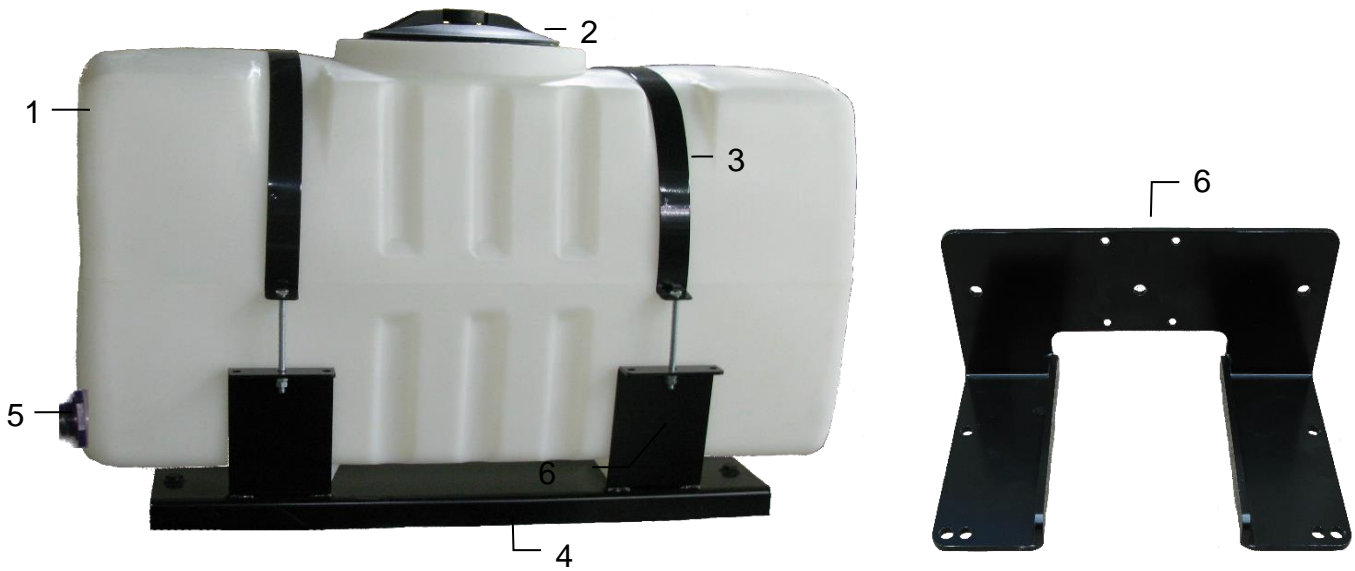

<u>Ref#</u>	<u>Description</u>	<u>Part #</u>	<u>Qty</u>	<u>Ref#</u>	<u>Description</u>	<u>Part #</u>	<u>Qty</u>
1	Tank	005-9203SQ	1	4	Tank Saddle	001-4703X	1
2	Tank lid	005-9022H	1	5	Tank fitting	005-9100	1
3	Tank straps	001-4402	2	6	Pump Plate Mount	001-4647	1

Tank Saddle Kit (1-5) 030-0432-TK
 4647 Mount Kit (6) PMP-4647MT

Model 345 Base Kit

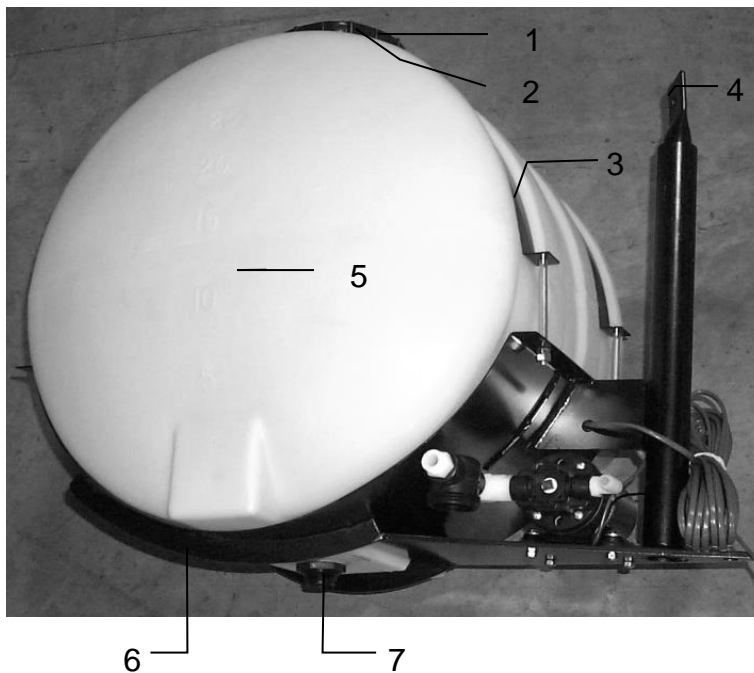

<u>Ref</u>	<u>Description</u>	<u>Part #</u>	<u>Qty</u>
1	Tank Cap	005-9022C	1
2	Tank Cap Gasket	005-9022CG	1
3	Tank Strap	001-4402	2
4	Stub Pipe	001-4403	1
5	Tank	005-9022	1
6	Saddle	001-4401	1
7	Tank Fitting	005-9100	1

*25 Gal Tank Includes Bottom Fitting Only
 Tank Saddle Kit 030-0441-TK

Model 350 Base Kit

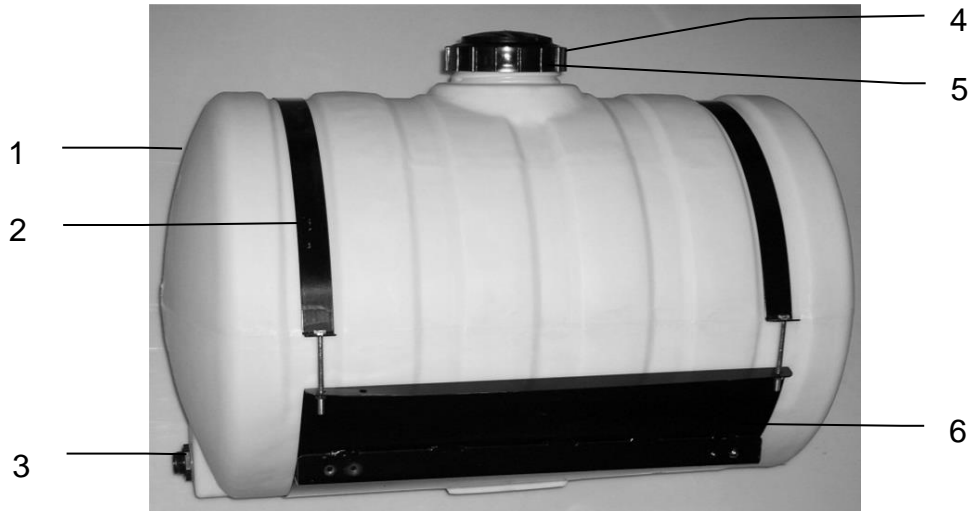

<u>Ref#</u>	<u>Description</u>	<u>Part #</u>	<u>Qty</u>	<u>Ref#</u>	<u>Description</u>	<u>Part #</u>	<u>Qty</u>
1	Tank	005-9203	1	4	Tank Cap	002-9022C	1
2	Straps	001-4402	2	5	Tank Gasket	002-9022CG	1
3	Tank Fitting	005-9100	1	6	Saddle	001-4703	1

*55 Gal Tank Includes Side Tank Fitting Only
 Complete Saddle Kit 030-0448-TK

Model 351 Base Kit

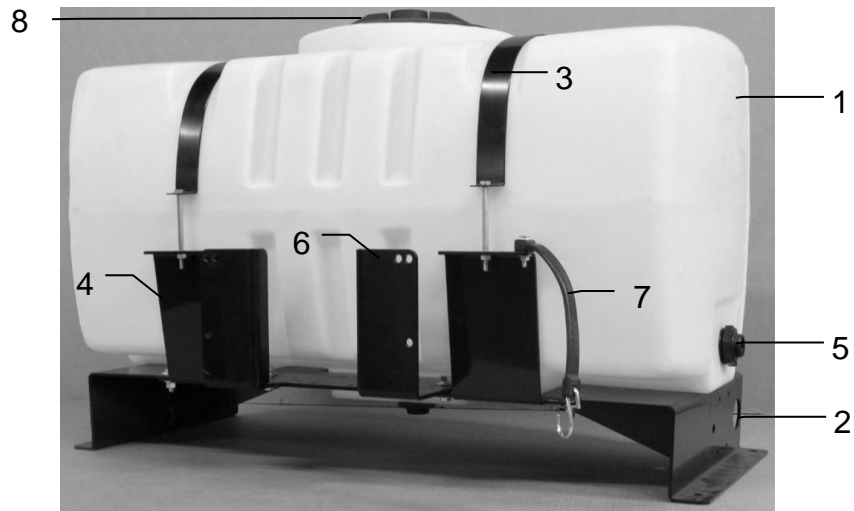

<u>Ref#</u>	<u>Description</u>	<u>Part #</u>	<u>Qty</u>	<u>Ref#</u>	<u>Description</u>	<u>Part #</u>	<u>Qty</u>
1	Tank	005-9203SQ	1	6	Mounting Bracket	001-4647	1
2	Tank Saddle	001-4703C	1	7	Door Latch	001-4703CL	1
3	Tank Straps	001-4402	2	8	Tank Lid	005-9022H	1
4	Short Strap Base	001-4703CC	2	NP	Long Strap Base	001-4703CD	2
5	Tank fitting	005-9100	2				

*Tank Includes Cap, Bottom & Side Tank Fitting
 Complete Saddle Kit (1-5,7-NP) 030-0440-TK
 4647 Mount Kit (6) PMP-4647MT

Parts Breakdown for Pump Assembly

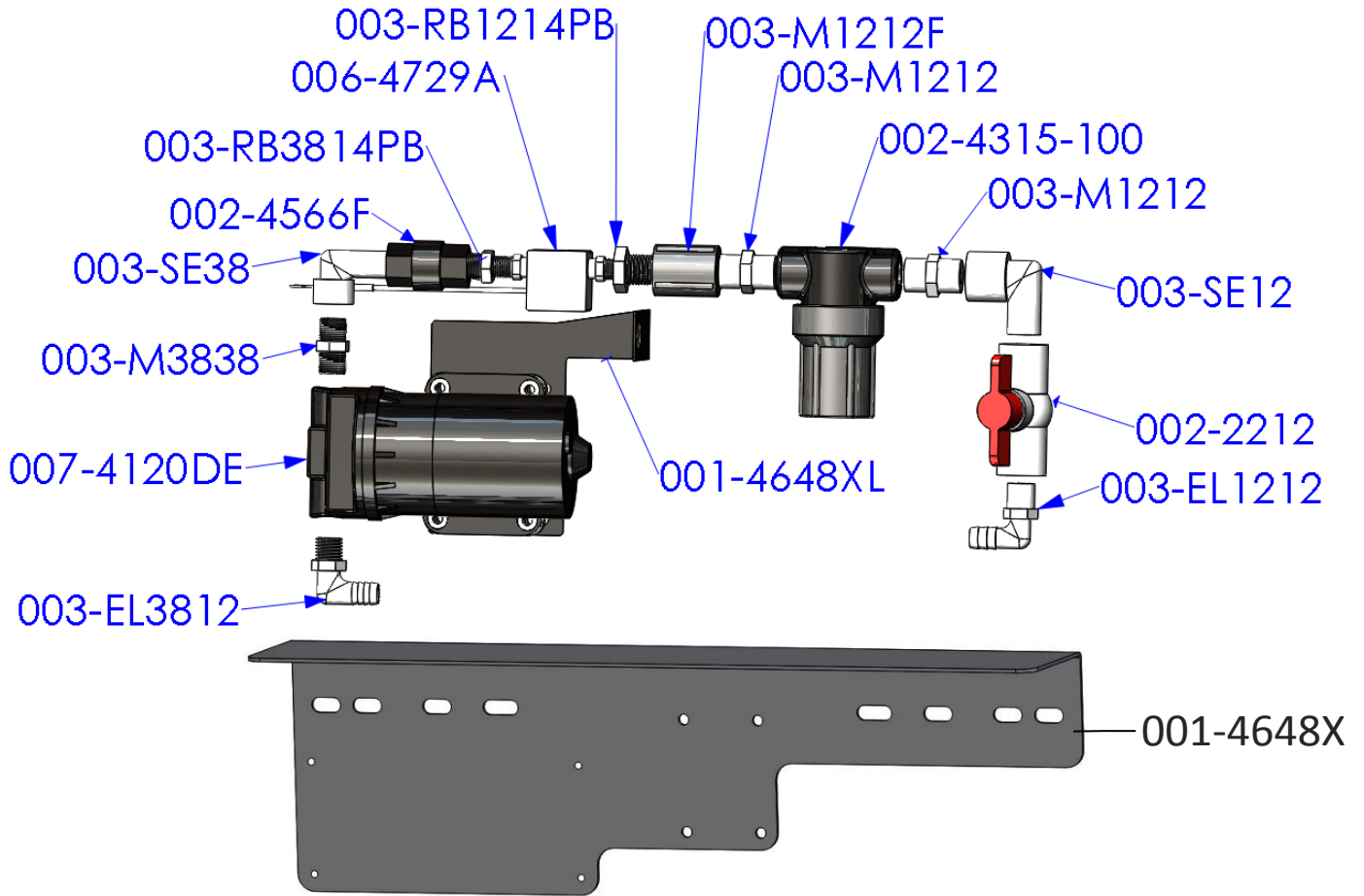

<u>Part#</u>	<u>Description</u>	<u>Qty</u>	<u>Part#</u>	<u>Description</u>	<u>Qty</u>
003-EL3812	3/8" MPT X 1/2" HB Elbow	1	003-M1212	1/2" Union	2
007-4120DE	300 Series Pump	1	002-4315-100	1/2" Line Strainer-100 Mesh	1
003-M3838	3/8" x 3/8" Union	1	003-SE12	1/2" Street Elbow	1
003-SE38	3/8" Street Elbow	1	002-2212	1/2" Ball Valve	1
002-4566F	3/8" Check Valve	1	003-EL1212	1/2" MPT x 1/2" HB	1
003-RB3814PB	RB 3/8" x 1/4" Reducer	1	001-4648XL	300 Pump Support	1
006-4729A	Flow Meter – Block Style	1	001-4648X	Pump Plate Mount	1
003-RB1214PB	RB 1/2" x 1/4" Reducer	1	003-A1212	Not Pictured	
003-M1212F	1/2" Coupler	1	003-A3812	Not Pictured	

Pump Assembly PMP-3636P (001-4648X Not Included)

Completed Assembly

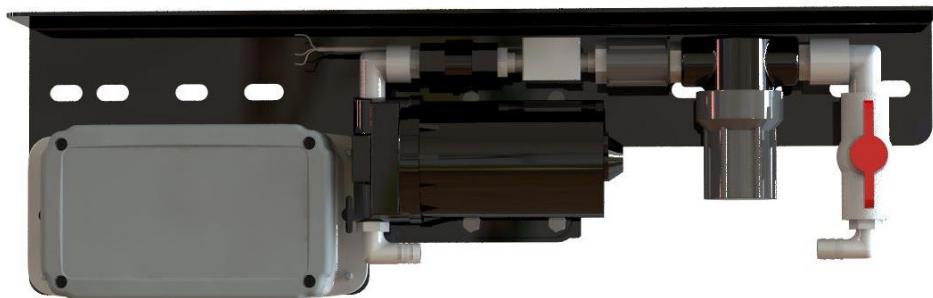

*Note: Due to alternative baler designs, elbow 003-EL3812 can be replaced by straight fitting 003-A3812. As well as elbow 003-EL1212 can be replaced by straight fitting 003-A1212. Both straight fittings are included.

Star Wheel Sensors

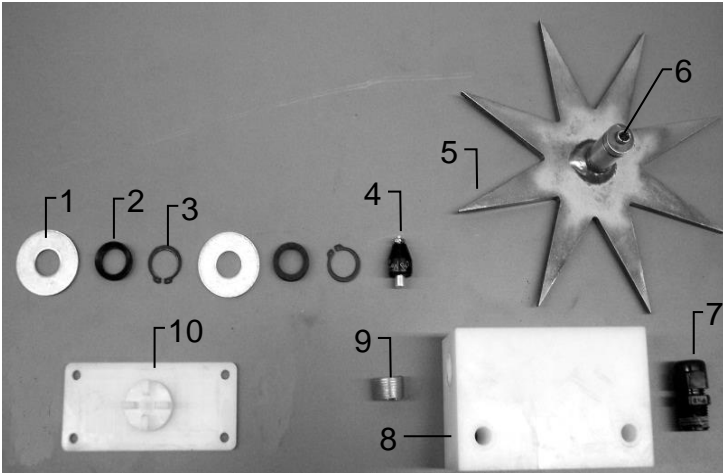

<u>Ref</u>	<u>Description</u>	<u>Part#</u>	<u>Qty</u>
1	Washer (per side)	006-4642K	2
2	Dust Seal (per side)	w/006-4642K	1
3	Snap Ring (per side)	w/006-4642K	2
4	Swivel	006-4642A	2
5	Star Wheel	030-4641E	2
6	Insert	w/ Ref # 5	2
7	Wiring grommet	008-0821A	2
8	Star wheel block	006-4641D	2
9	Plug Fitting	003-F38	2
10	Block Cover	006-4641B	2
1-10	Star wheel assembly	030-4642	2

Hoses

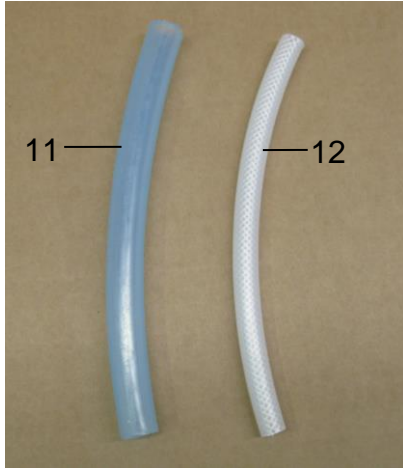

<u>Ref</u>	<u>Description</u>	<u>Part #</u>	<u>Qty</u>
11	1/2" Hose (Tank to Solenoid)	002-9001	15ft
12	1/4" Hose (Solenoid to Tips)	002-9016	6ft

Moisture Harness



<u>Ref</u>	<u>Description</u>	<u>Part #</u>	<u>Qty</u>
NP	Moisture Harness (344,345,350 Kits)	006-4640D2	1
NP	Moisture Harness (351 Kit)	006-4640K2	1

Control Box and Wiring Harnesses

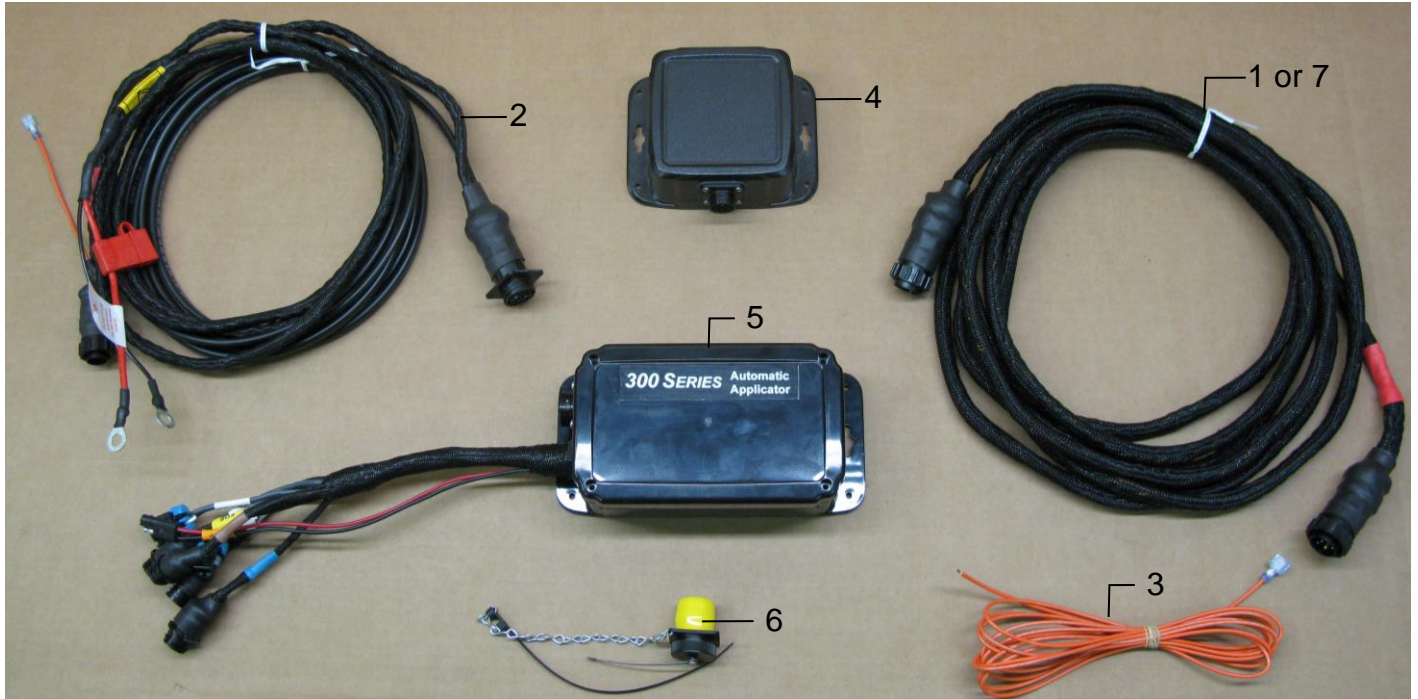

<u>Ref</u>	<u>Description</u>	<u>Part#</u>	<u>Qty</u>	<u>Ref</u>	<u>Description</u>	<u>Part#</u>	<u>Qty</u>
1	Power lead baler 20' (344, 345, 350 Kits)	006-3650B1	1	5	300 Series Controller	006-3671SS	1
2	Power lead tractor	006-3650T	1	6	Dust Plugs	006-5651Plugs	1
3	Key Switch Wire	006-5650K	1	7	Power lead baler 30' (451)	006-3650B2	1
4	Bluetooth Receiver	006-6672A	1	NP	Moisture Harness (344,345,350 Kits)	006-4640D2	1
				NP	Moisture Harness (351 Kit)	006-4640K2	1
					Complete Assembly (1-6)	030-362CPA	
					Complete Assembly (2-7)	030-362CPB	

End of Bale Sensor Kit A

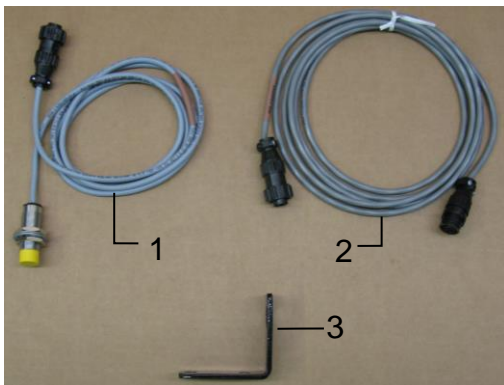

<u>Ref</u>	<u>Description</u>	<u>Part #</u>	<u>Qty</u>
1	End of Bale Sensor	006-7400	1
2	EOB Extension	006-7400EXT	1
3	End of Bale Bracket	001-4648SS	1
	Complete Assembly	EOB-SS-A	

End of Bale Sensor Kit B

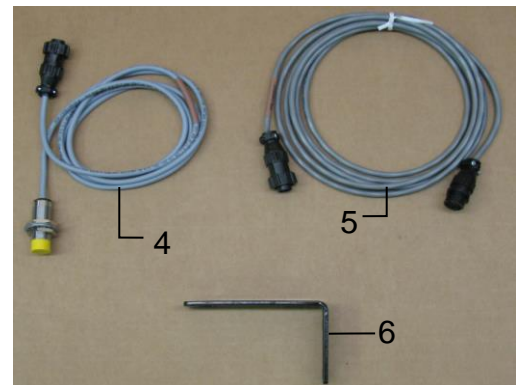

<u>Ref</u>	<u>Description</u>	<u>Part #</u>	<u>Qty</u>
4	End of Bale Sensor	006-7400	1
5	EOB Extension	006-7400EXT	1
6	End of Bale Bracket	001-4648SI	1
	Complete Assembly	EOB-SS-B	

300 Solenoid Packages

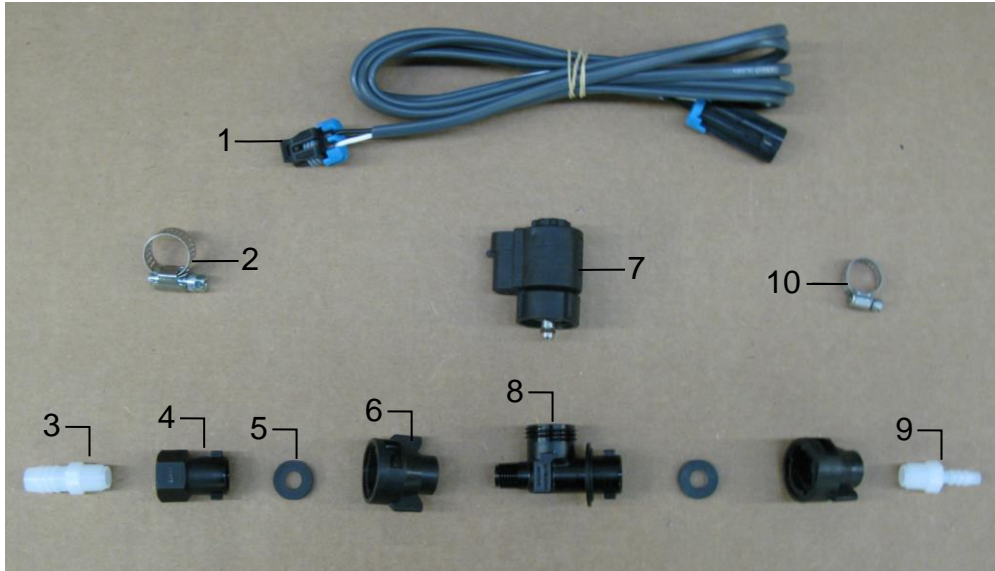

Solenoid Package A (Applicator Kit: 351)

<u>Ref</u>	<u>Description</u>	<u>Part #</u>	<u>Qty</u>	<u>Ref</u>	<u>Description</u>	<u>Part #</u>	<u>Qty</u>
1	Solenoid Harness (5')	006-3650-S1	1	6	1/4" Female Disconnect	004-1207H	2
2	#6 Hose Clamp	003-9003	1	7	Solenoid	002-2203F	1
3	1/4" x 1/2" Straight Fitting	003-A1412	1	8	Solenoid Valve Body	004-1207VF	1
4	1/4" Female Connector	004-1207G	1	9	1/4" x 1/4" Straight Fitting	003-A1414	1
5	Rubber Washer	004-1207W	2	10	Mini Hose Clamp	003-9002	1
Complete Assembly						SOL-3SP-A	

Solenoid Package B (Applicator Kits: 344, 345, 350)

<u>Ref</u>	<u>Description</u>	<u>Part #</u>	<u>Qty</u>	<u>Ref</u>	<u>Description</u>	<u>Part #</u>	<u>Qty</u>
1	Solenoid Harness (10')	006-3650-S2	1	6	1/4" Female Disconnect	004-1207H	2
2	#6 Hose Clamp	003-9003	1	7	Solenoid	002-2203F	1
3	1/4" x 1/2" Straight Fitting	003-A1412	1	8	Solenoid Valve Body	004-1207VF	1
4	1/4" Female Connector	004-1207G	1	9	1/4" x 1/4" Straight Fitting	003-A1414	1
5	Rubber Washer	004-1207W	2	10	Mini Hose Clamp	003-9002	1
Complete Assembly						SOL-3SP-B	

Parts Bag Packages

PBA-1

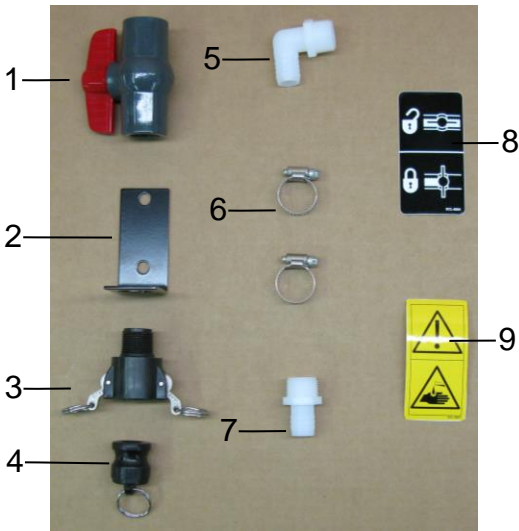

<u>Ref</u>	<u>Description</u>	<u>Part #</u>	<u>Qty</u>
1	3/4" Ball Valve	002-2200	1
2	Valve Holder	001-6702H	1
3	Female Coupler	002-2204A	1
4	Male Shut-Off Plug	002-2205G	1
5	3/4" x 3/4" Elbow	003-EL3434	1
6	#10 Hose Clamp	003-9004	2
7	3/4" x 3/4" Straight Fitting	003-A3434	1
8	Valve Decal	DCL-8004	1
9	Chemical Hazard Decal	DCL-8001	1
Complete Drain Fill Kit		030-0493DFK	

PBP-16

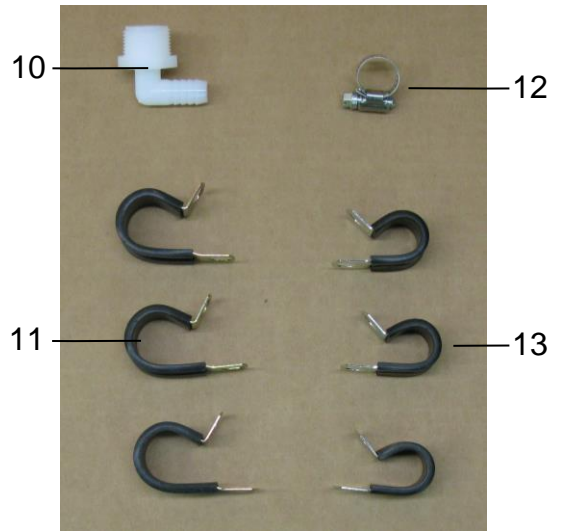

<u>Ref</u>	<u>Description</u>	<u>Part #</u>	<u>Qty</u>
10	3/4" x 1/2" Elbow	003-EL3412	1
11	3/4" Jiffy Clip	008-9010	3
12	#6 Hose Clamp	003-9003	1
13	Small Jiffy Clip	008-9009	3

PBP-12

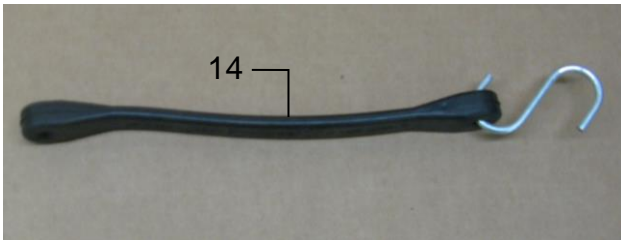

<u>Ref</u>	<u>Description</u>	<u>Part #</u>	<u>Qty</u>
14	Door Latch	001-4703CL	1

PBP-17

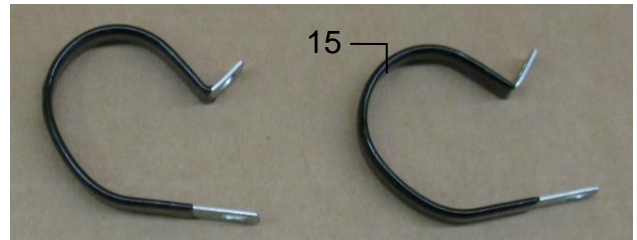

<u>Ref</u>	<u>Description</u>	<u>Part #</u>	<u>Qty</u>
15	Vinyl Clamp	008-9013	1

Optional iPad Mini Mounting Kit (030-2014MK)

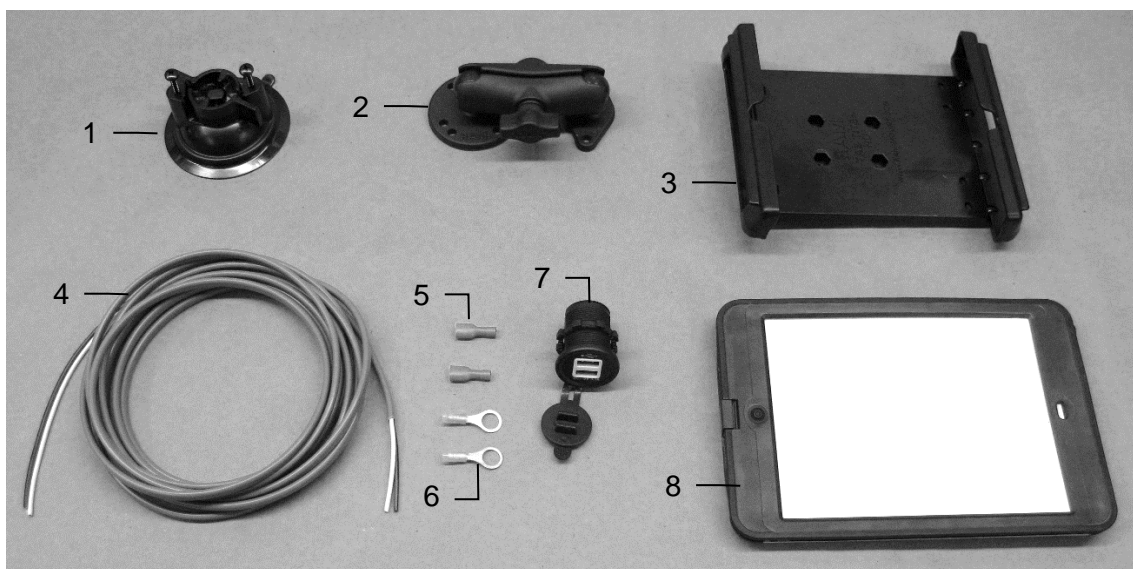

<u>Ref</u>	<u>Description</u>	<u>Part #</u>	<u>Qty</u>
1	Suction cup mount	001-2012SCM	1
2	Ram mount	001-2012H	1
3	iPad Mini spring load cradle (Mini 2)	001-2012SLC	1
4	16 gauge power wire	006-4723P	1
5	Female spade connector	Hardware	2
6	Eye loop connector	Hardware	2
7	iPad Mini Charger 12V	001-2012P	1
8	iPad Mini 4 case	001-2012C4	1
NP	4 amp fuse	Hardware	1
	Mounting Kit Assembly	030-2014MK (Includes All Parts)	

Installation Instructions

1. Identify 12V power source for wires to connect.
 - a. Eye loops included if wiring directly to the battery is desired.
 - b. Test for key power source if preferred to have power to the USB shut off with the key.
2. Once power source is identified, cut wires to desired length.
3. Crimp the two supplied quick connectors onto each the white and black wire.
4. Remove the round locking plastic nut from USB plug before connecting the wires. Black (+) White (-).
5. The wires will then be hooked to the designated terminals on the bottom of the USB plug
6. Drill a 1 1/8" hole in the preferred mounting location. Be sure to clean any sharp edges after drilling.
7. Feed the wires through the mounting hole.
8. If using the round plastic nut to secure plug in place, slide the nut back over the wiring before connecting the wires to powered source.
9. Connect the wires to the identified power source if easier to do so before tightening the plug into place.
10. Tighten plug using either the round plastic nut or mounting plate and two screws, both options supplied.
11. Once connected, hook a USB charging cord into the plug and connect a mobile device/tablet to ensure the plug is operating as you wish (key power working properly if necessary).

NOTE: This plug is not designed to charge two iPads. System damage could occur if this is attempted. System will charge a mobile phone and iPad simultaneously without problem.

Optional iPad Display Kit (030-4670DK)

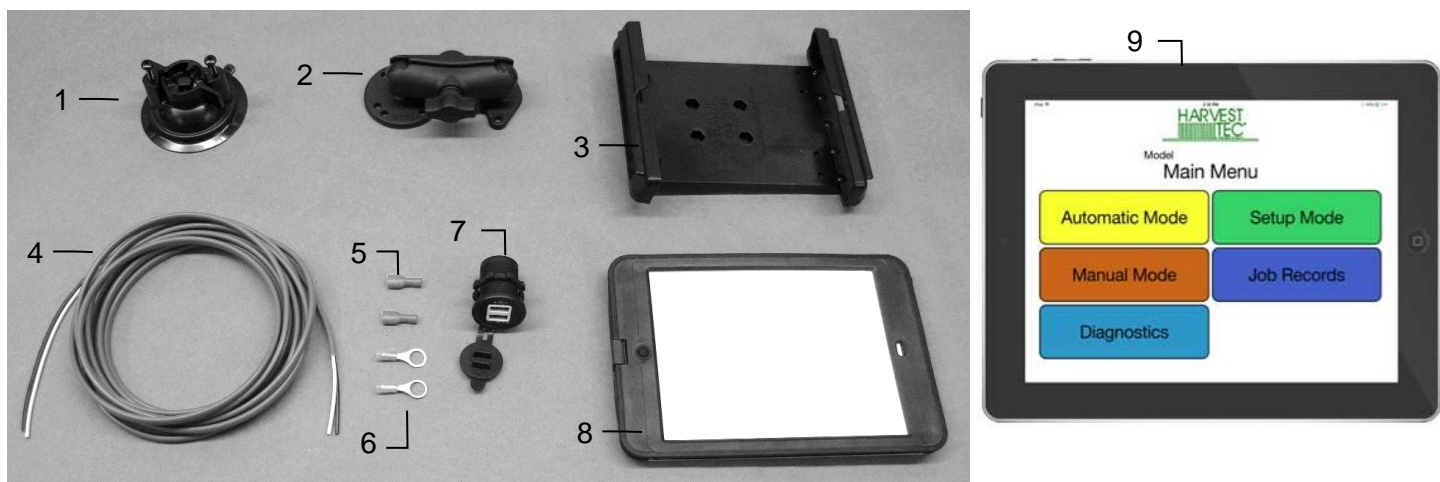

Ref	Description	Part #	Qty	Ref	Description	Part #	Qty
1	Suction cup mount	001-2012SCM	1	7	iPad Mini Charger 12V	001-2012P	1
2	Ram mount	001-2012H	1	8	iPad Mini 4 case	001-2012C4	1
3	iPad Mini spring load cradle (Mini 4)	001-2012SLC	1	9	iPad Mini 4	006-2670IP	1
4	16 gauge power wire	006-4723P	1	NP	4 amp fuse	Hardware	1
5	Female spade connector	Hardware	2				
6	Eye loop connector	Hardware	2		Mounting Kit Assembly	030-4670DK (Includes All Parts)	

Installation Instructions

1. Identify 12V power source for wires to connect.
2. Eye loops included if wiring directly to the battery is desired.
3. Test for key power source if preferred to have power to the USB shut off with the key.
4. Once power source is identified, cut wires to desired length.
5. Crimp the two supplied quick connectors onto the white and black wire.
6. Remove the round locking plastic nut from USB plug before connecting the wires. Black (+) White (-).
7. The wires will then be hooked to the designated terminals on the bottom of the USB plug
8. Drill a 1 1/8" hole in the preferred mounting location. Be sure to clean any sharp edges after drilling.
9. Feed the wires through the mounting hole.
10. If using the round plastic nut to secure plug in place, slide the nut back over the wiring before connecting the wires to powered source.
11. Connect the wires to the identified power source if easier to do so before tightening the plug into place.
12. Tighten plug using either the round plastic nut or mounting plate and two screws, both options supplied.
13. Once connected, hook a USB charging cord into the plug and connect a mobile device/tablet to ensure the plug is operating as you wish (key power working properly if necessary).

NOTE: This plug is not designed to charge two iPads. System damage could occur if this is attempted. System will charge a mobile phone and iPad simultaneously without problem.

Model 4409C Installation Kit

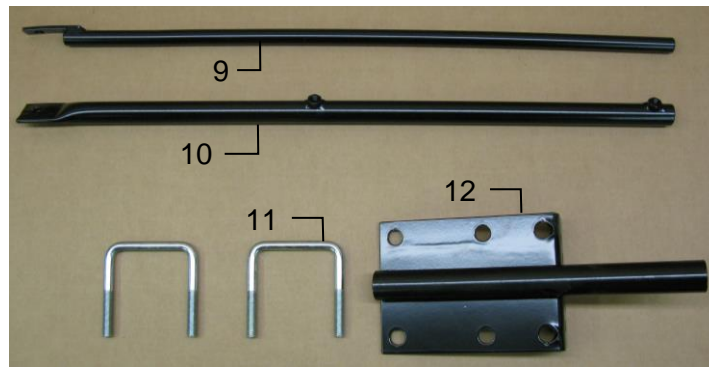
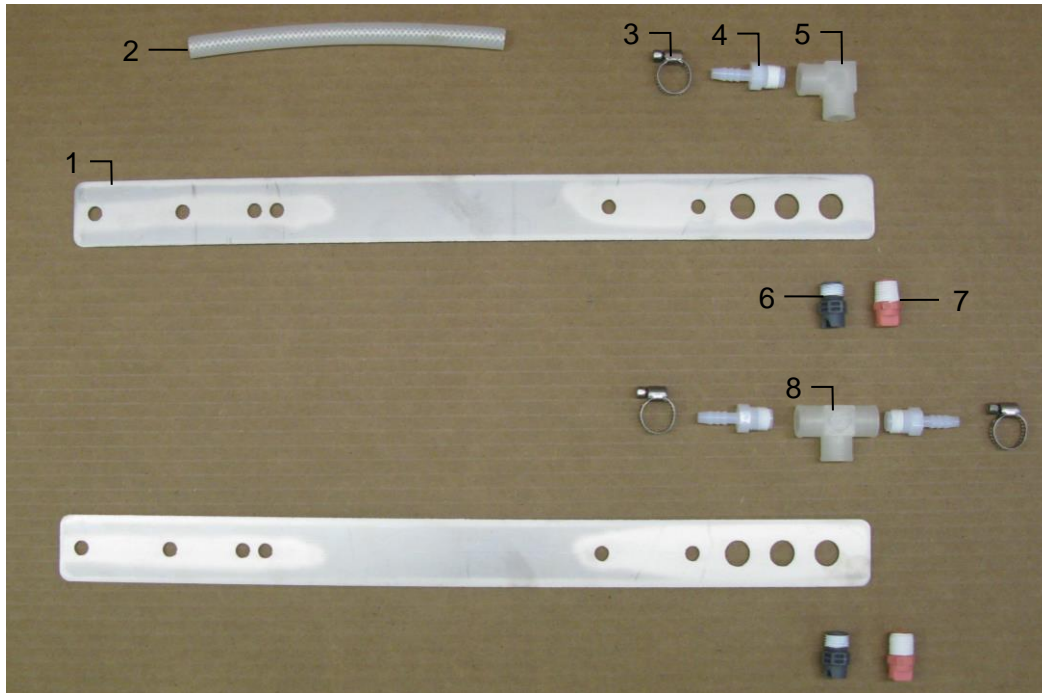

<u>Ref</u>	<u>Description</u>	<u>Part #</u>	<u>Qty</u>	<u>Ref</u>	<u>Description</u>	<u>Part #</u>	<u>Qty</u>
1	Nozzle Holder	001-4215	2	8	1/4" Tee Sq	003-TT14SQ	1
2	1/4" Hose	003-9016	3	9	Reach Rod – Outside	001-4404	1
3	Mini Hose Clamp	003-9002	3	10	Reach Rode – Inside	001-4405	1
4	1/4" x 1/4" Straight Fitting	003-A1414	3	11	1/2" x 4" U-Bolt	001-4406A	2
5	1/4" Female Street Elbow	003-SE14F	1	12	Base Bracket	001-4406	1
6	Tip – Grey	004-T6504-PT	2				
7	Tip – Pink	004-T6501-PT	2				
					Shield Only (Ref 1-8)	030-4409C-SO	
					Tank Mount Kit (Ref 9-12)	TMK-4401	
					Complete Assembly	030-4409C	

Model 4410C Installation Kit

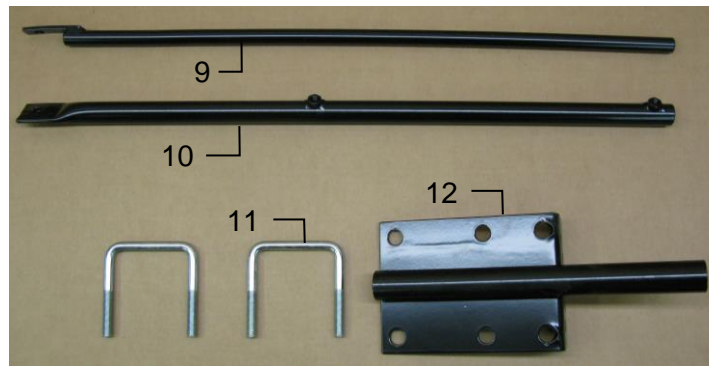
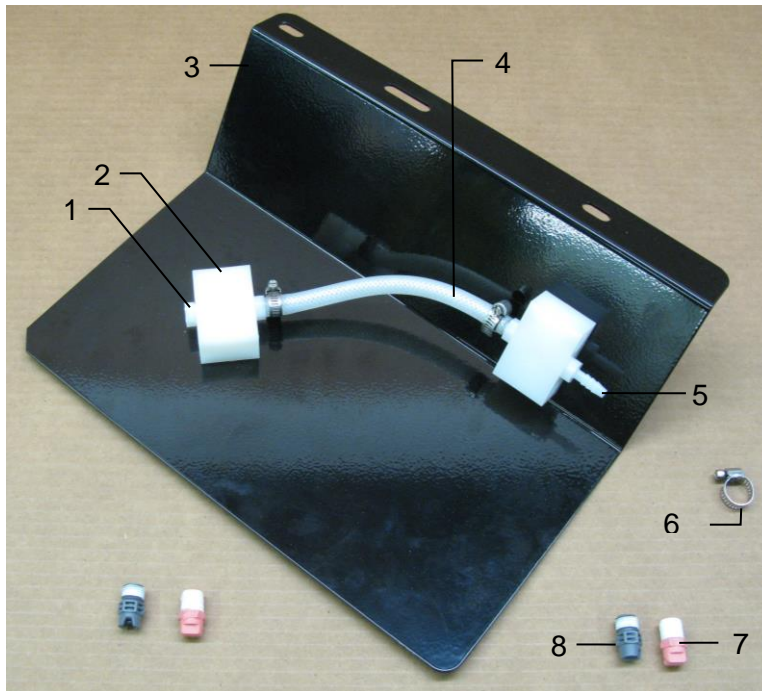

<u>Ref</u>	<u>Description</u>	<u>Part #</u>	<u>Qty</u>	<u>Ref</u>	<u>Description</u>	<u>Part #</u>	<u>Qty</u>
1	1/4" Hex Plug	003-F14	1	7	Tip – Pink	004-T6501-PT	2
2	Shield Manifold Block	001-4435NSB	2	8	Tip – Grey	004-T6504-PT	2
3	Nozzle Holder SS Block	001-4426A	1	9	Reach Rod – Outside	001-4404	1
4	1/4" Hose	002-9016	1	10	Reach Rode – Inside	001-4405	1
5	1/4" x 1/4" Straight Fitting	003-A1414	3	11	Base Bracket	001-4406	1
6	Mini Hose Clamp	003-9002	3	12	1/2" x 4" UBolt	001-4406A	2

Shield Only (Ref 1-8)	030-4410C-SO
Tank Mount Kit (Ref 9-12)	TMK-4401
Complete Assembly	030-4410C

Model 4412C Installation Kit

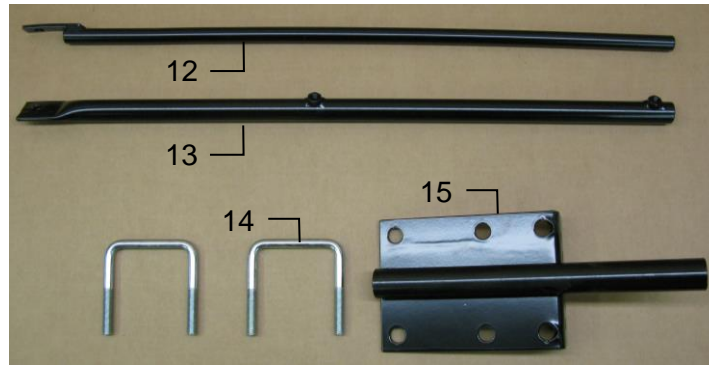
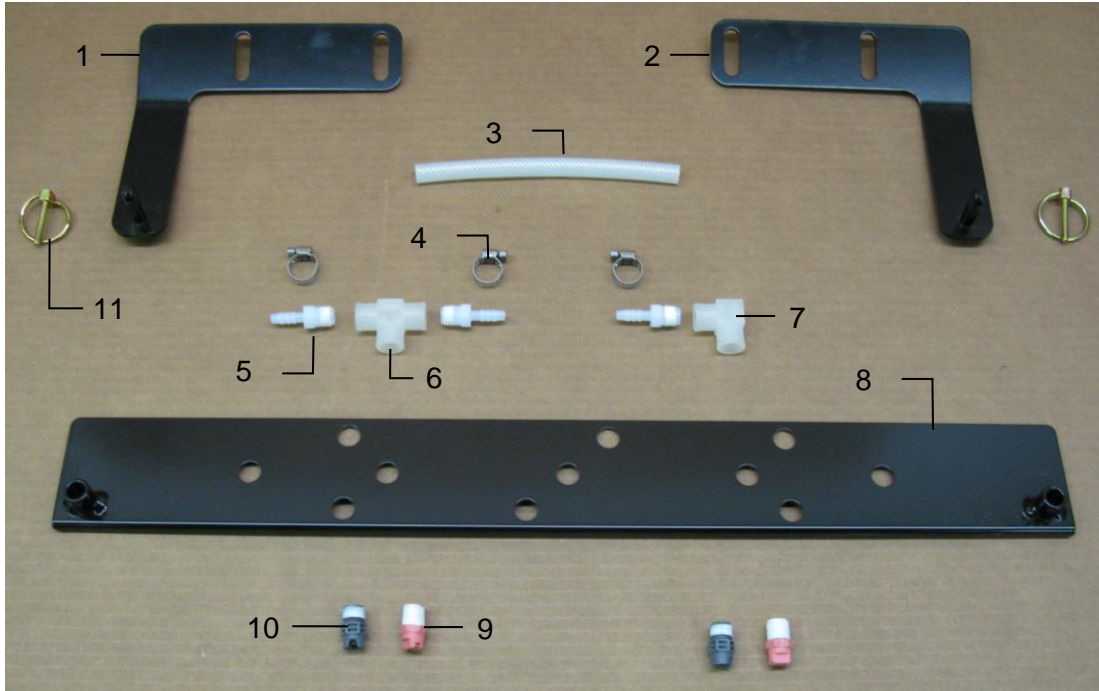

<u>Ref</u>	<u>Description</u>	<u>Part #</u>	<u>Qty</u>	<u>Ref</u>	<u>Description</u>	<u>Part #</u>	<u>Qty</u>
1	Left Mounting Bracket	001-4436DL	1	9	Tip – Pink	004-T6501-PT	2
2	Right Mounting Bracket	001-4436DR	1	10	Tip – Grey	004-T6504-PT	2
3	1/4" Hose	002-9016	1	11	3/16" Lynch Pin	008-4576	1
4	Mini Hose Clamp	003-9002	3	12	Reach Rod – Outside	001-4404	1
5	1/4" x 1/4" Straight Fitting	003-A1414	3	13	Reach Rode – Inside	001-4405	1
6	1/4" Sq Tee	003-TT14SQ	1	14	1/2" x 4" UBolt	001-4406A	2
7	1/4" Female St Elbow	003-SE14F	1	15	Base Bracket	001-4406	1
8	Tip Holder Spray Shield	001-4810	1				
					Shield Only (Ref 1-11)	030-4412C-SO	
					Tank Mount Kit (Ref 12-15)	TMK-4401	
					Complete Assembly	030-4412C	

Model 4415C Installation Kit

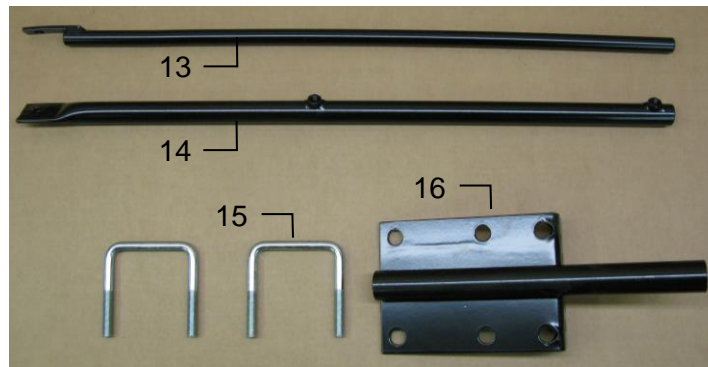
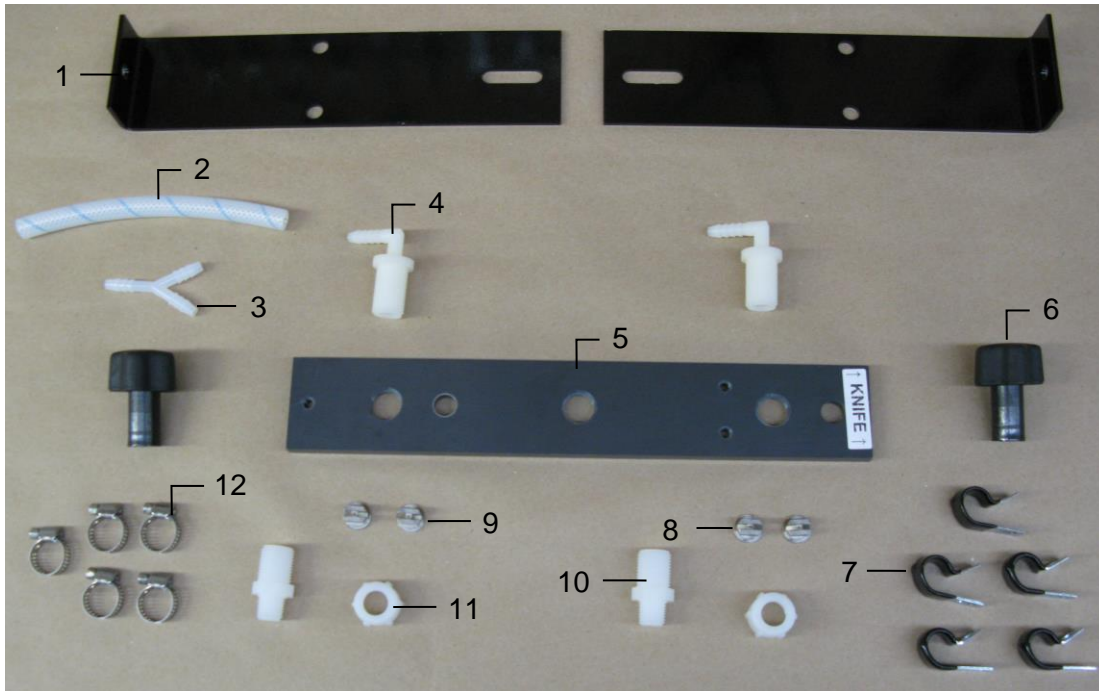

<u>Ref</u>	<u>Description</u>	<u>Part #</u>	<u>Qty</u>	<u>Ref</u>	<u>Description</u>	<u>Part #</u>	<u>Qty</u>
1	Hose Support	001-4425B	2	8	Tip – Low Output	004-11001-SS	2
2	1/4" Hose	002-9016	3	9	Tip – High Output	004-11004-SS	2
3	Y Fitting	003-Y1414	1	10	1/4" Drill Guide	003-M3814NB	1
4	1/4" Nozzle Body Elbow	003-EL3814NB	2	11	Nozzle Cap	003-BC12	2
5	Hay Guard Shield	001-4425C	1	12	Mini Hose Clamp	003-9002	5
6	SS Manifold Knob	008-0925	2	13	Reach Rod – Outside	001-4404	1
7	477 Jiffy Clips	008-9014	5	14	Reach Rode – Inside	001-4405	1
				15	1/2" x 4" UBolt	001-4406A	2
				16	Base Bracket	001-4406	1
					Shield Only (Ref 1-12)	030-4415C-SO	
					Tank Mount Kit (Ref 13-15)	TMK-4401	
					Complete Assembly	030-4415C	

Model 4416C Installation Kit

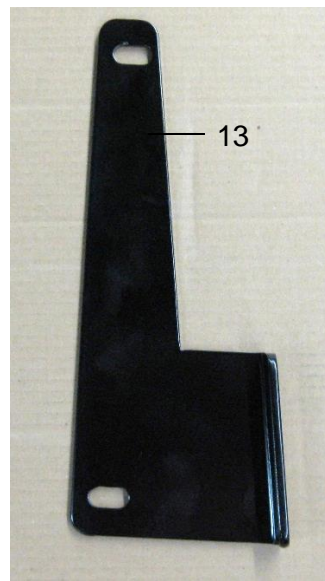
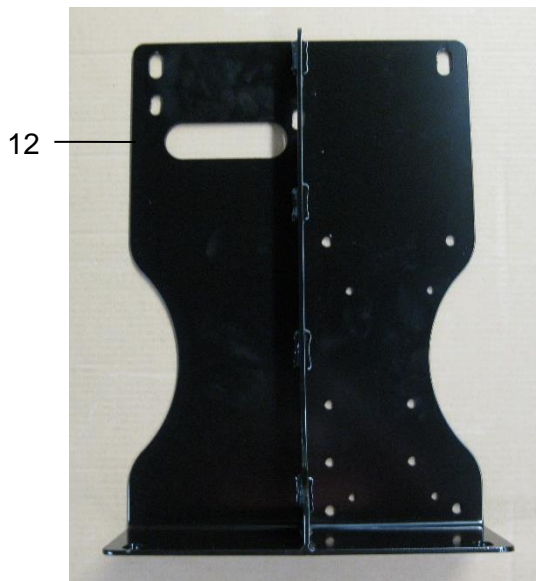
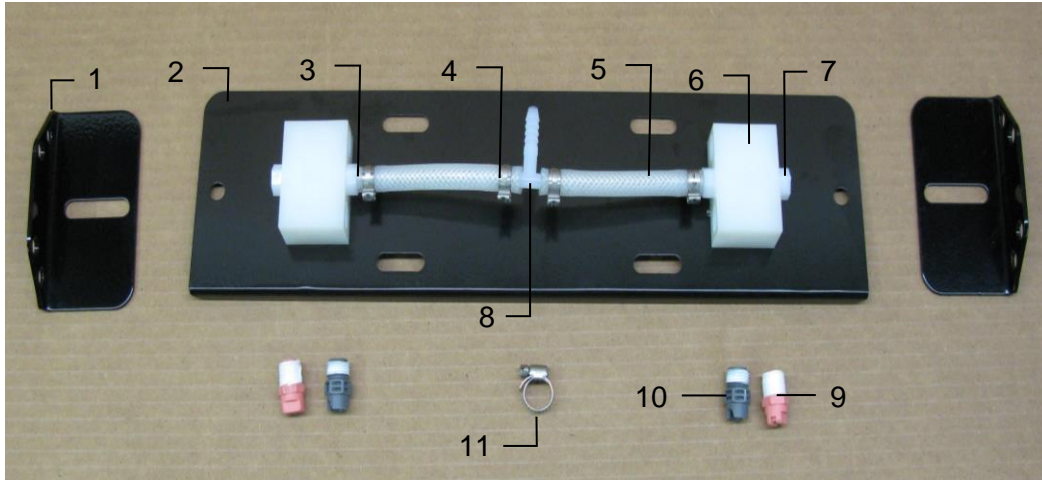

<u>Ref</u>	<u>Description</u>	<u>Part #</u>	<u>Qty</u>	<u>Ref</u>	<u>Description</u>	<u>Part#</u>	<u>Qty</u>
1	Spray Shield Holders	001-4424B	2	8	1/4" Tee	003-T1414	1
2	Spray Shield	001-4424A2	1	9	Tip - Pink	004-T6501-PT	2
3	1/4" Straight Fitting	003-A1414	2	10	Tip - Grey	004-T6504-PT	2
4	1/2" Otiker Clamp	003-9008	4	11	Mini Hose Clamps	003-9002	1
5	1/4" Hose	002-9016	1	12	Saddle Legs	001-4703Q	2
6	Manifold Block	001-4435NSB	2	13	Kicker Bracket	001-4703QC	1
7	Hex Plug	003-F14	2				

Shield Only (Ref 1-11)	030-4416C-SO
Tank Mount Kit (Ref 12-13)	TMK-4416
Complete Assembly	030-4416C

Model 4485C Installation Kit

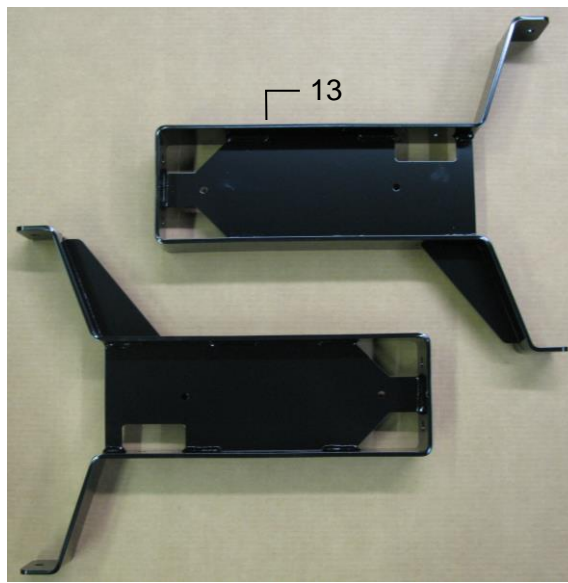
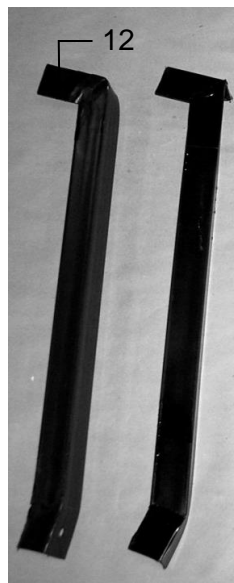
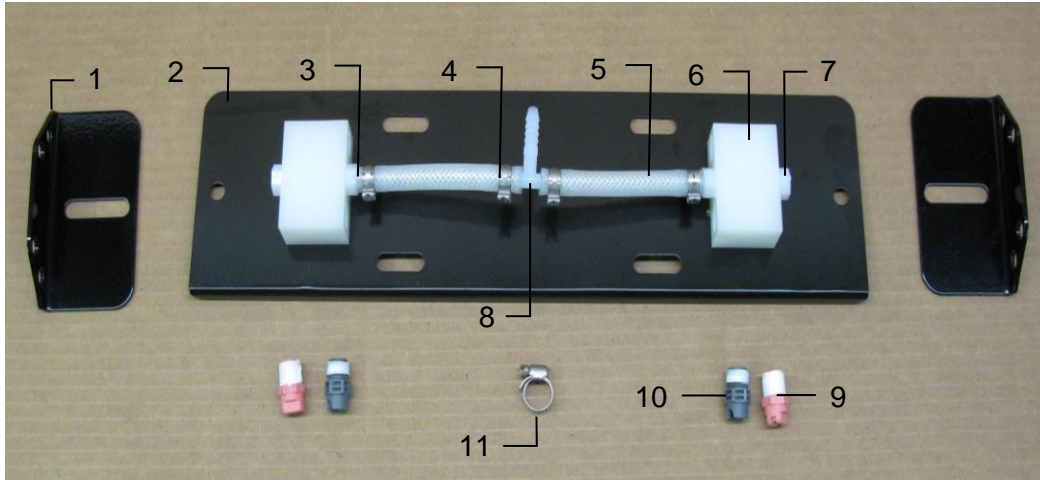

<u>Ref</u>	<u>Description</u>	<u>Part #</u>	<u>Qty</u>	<u>Ref</u>	<u>Description</u>	<u>Part #</u>	<u>Qty</u>
1	Spray Shield Holders	001-4424B	2	8	1/4" Tee	003-T1414	1
2	Spray Shield	001-4424A2	1	9	Tip - Pink	004-T6501-PT	2
3	1/4" Straight Fitting	003-A1414	2	10	Tip - Grey	004-T6504-PT	2
4	1/2" Otiker Clamp	003-9008	4	11	Mini Hose Clamps	003-9002	1
5	1/4" Hose	002-9016	1	12	Support Bracket	001-4424C	2
6	Manifold Block	001-4435NSB	2	13	55 Gal Long Leg	001-4703B	2
7	Hex Plug	003-F14	2				
					Shield Only (Ref 1-11)	030-4416C-SO	
					Tank Mount Kit (Ref 12-13)	TMK-4485	
					Complete Assembly	030-4485C	

Model 4502C Installation Kit

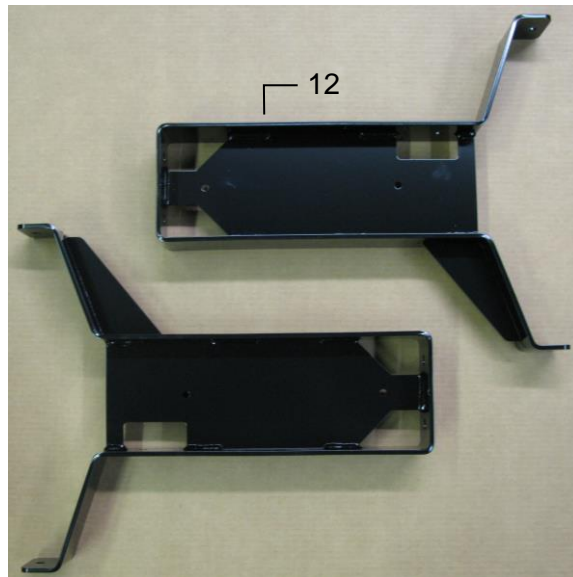
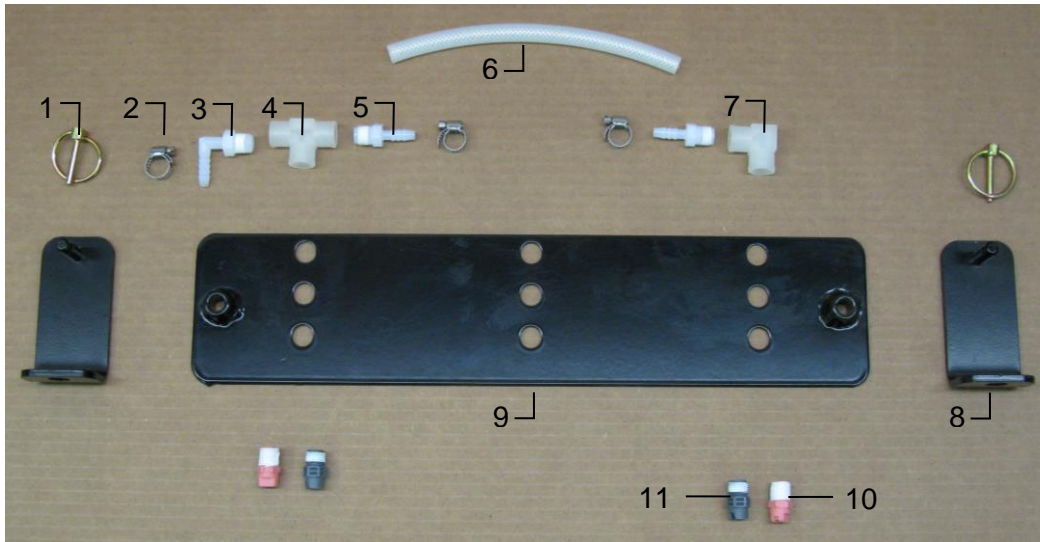

<u>Ref</u>	<u>Description</u>	<u>Part #</u>	<u>Qty</u>	<u>Ref</u>	<u>Description</u>	<u>Part #</u>	<u>Qty</u>
1	3/16" Lynch Pin	008-4576	2	8	Shield Holder	001-4703I	2
2	Mini Hose Clamp	003-9002	3	9	Spray Shield	001-4703G	1
3	1/4" x 1/4" Elbow	003-EL1414	1	10	Tip – Pink	004-T6501-PT	2
4	1/4" Tee Sq	003-TT14SQ	1	11	Tip – Grey	004-T6504-PT	2
5	1/4" x 1/4" Straight fitting	003-A1414	2	12	55 Gal Long Leg	001-4703B	2
6	1/4" Hose	002-9016	1				
7	1/4" Female Street Elbow	003-SE14F	1				

Shield Only (Ref 1-11)	030-4502C-SO
Tank Mount Kit (Ref 12)	TMK-4703B
Complete Assembly	030-4502C

Model 4506C Installation Kit

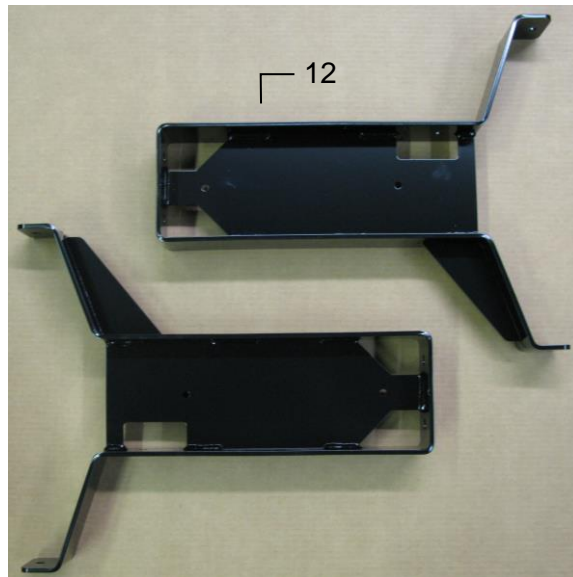
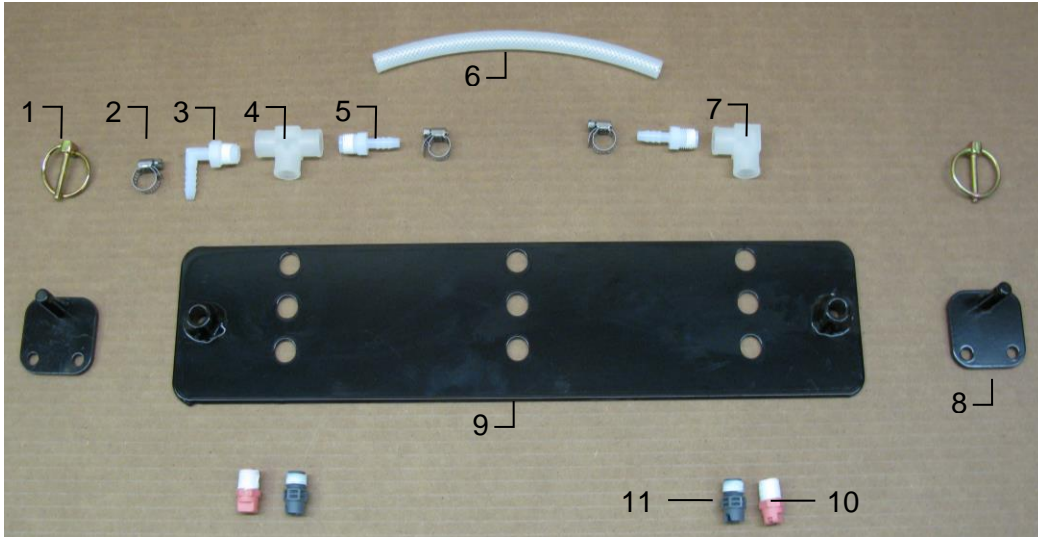

<u>Ref</u>	<u>Description</u>	<u>Part #</u>	<u>Qty</u>	<u>Ref</u>	<u>Description</u>	<u>Part #</u>	<u>Qty</u>
1	3/16" Lynch Pin	008-4576	2	8	Shield Holder	001-4703H	2
2	Mini Hose Clamp	003-9002	3	9	Spray Shield	001-4703G	1
3	1/4" x 1/4" Elbow	003-EL1414	1	10	Tip – Pink	004-T6501-PT	2
4	1/4" Tee Sq	003-TT14SQ	1	11	Tip – Grey	004-T6504-PT	2
5	1/4" x 1/4" Straight fitting	003-A1414	2	12	55 Gal Long Leg	001-4703B	2
6	1/4" Hose	002-9016	1				
7	1/4" Female Street Elbow	003-SE14F	1				
					Shield Only (Ref 1-11)	030-4506C-SO	
					Tank Mount Kit (Ref 12-15)	TMK-4703B	
					Complete Assembly	030-4506C	

Model 4507C Installation Kit

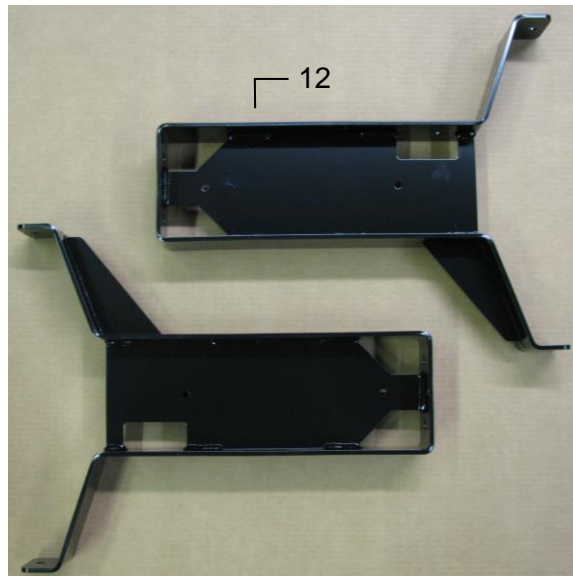
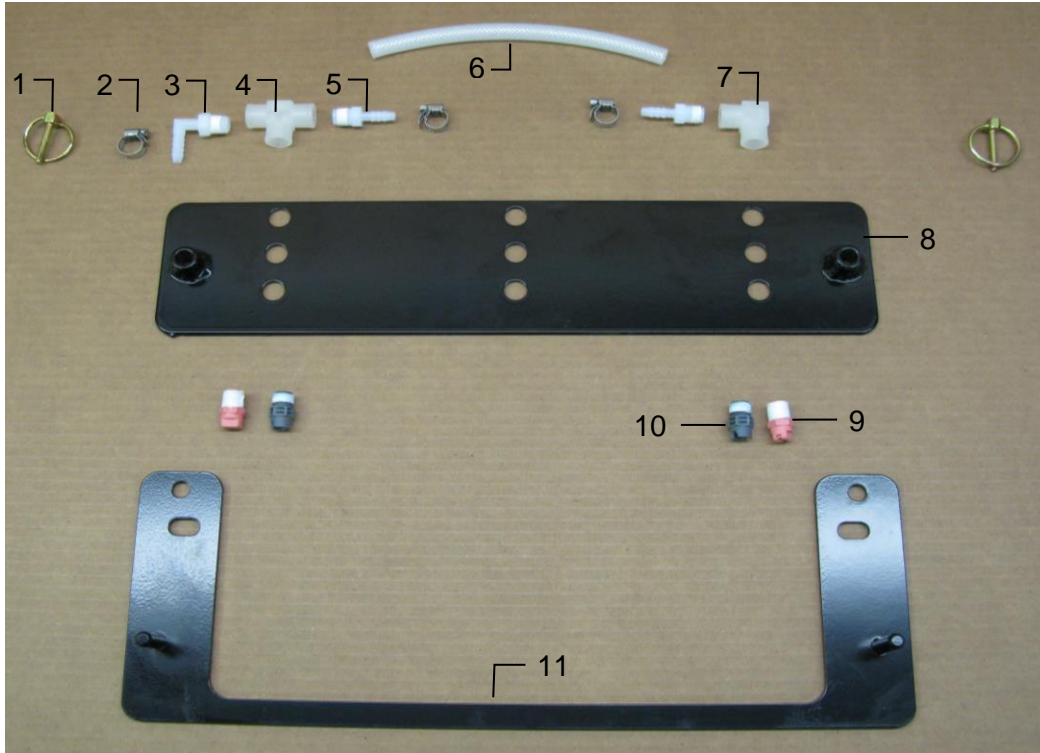

<u>Ref</u>	<u>Description</u>	<u>Part #</u>	<u>Qty</u>	<u>Ref</u>	<u>Description</u>	<u>Part #</u>	<u>Qty</u>
1	Lynch Pin	008-4576	2	8	Spray Shield	001-4703G	1
2	Mini Hose Clamp	003-9002	3	9	Tip – Pink	004-T6501-PT	2
3	1/4" x 1/4" Elbow	003-EL1414	1	10	Tip – Grey	004-T6504-PT	2
4	1/4" Tee Sq	003-TT14SQ	1	11	Shield Holder	001-4703J	2
5	1/4" x 1/4" Straight Fitting	003-A1414	2	12	55 Gal Long Leg	001-4703B	2
6	1/4" Hose	002-9016	1				
7	1/4" Female Street Elbow	003-SE14F	1				

Shield Only (Ref 1-11)
 Tank Mount Kit (Ref 12)
 Complete Assembly

030-4507C-SO
 TMK-4703B
 030-4507C

Notes

Harvest Tec Inc. Warranty and Liability Agreement

Harvest Tec, Inc. will repair or replace components that are found to be defective within 12 months from the date of manufacture. Under no circumstances does this warranty cover any components which in the opinion of Harvest Tec, Inc. have been subjected to negligent use, misuse, alteration, accident, or if repairs have been made with parts other than those manufactured and obtainable from Harvest Tec, Inc.

Our obligation under this warranty is limited to repairing or replacing free of charge to the original purchaser any part that in our judgment shows evidence of defective or improper workmanship, provided the part is returned to Harvest Tec, Inc. within 30 days of the failure. If it is determined that a non-Harvest Tec branded hay preservative has been used inside the Harvest Tec applicator system where the failure occurred, then Harvest Tec reserves the right to deny the warranty request at their discretion. Parts must be returned through the selling dealer and distributor, transportation charges prepaid.

This warranty shall not be interpreted to render Harvest Tec, Inc. liable for injury or damages of any kind, direct, consequential, or contingent, to persons or property. Furthermore, this warranty does not extend to loss of crop, losses caused by delays or any expense prospective profits or for any other reason. Harvest Tec, Inc. shall not be liable for any recovery greater in amount than the cost or repair of defects in workmanship.

There are no warranties, either expressed or implied, of merchantability or fitness for particular purpose intended or fitness for any other reason.

This warranty cannot guarantee that existing conditions beyond the control of Harvest Tec, Inc. will not affect our ability to obtain materials or manufacture necessary replacement parts.

Harvest Tec, Inc. reserves the right to make design changes, improve design, or change specifications, at any time without any contingent obligation to purchasers of machines and parts previously sold.

Revised 4/17

HARVEST TEC, INC.
P.O. BOX 63
2821 HARVEY STREET
HUDSON, WI 54016 USA
Phone: 715-386-9100
1-800-635-7465
Fax: 715-381-1792
Email: info@harvesttec.com