

Operation Manual

Model 300RB & 300RBC ***Moisture Only Kit for Round Balers***



P.O. Box 63 • 2821 Harvey Street • Hudson, WI 54016
800-635-7468 • www.harvesttec.com

(intentionally blank)

300RB & 300 RBC Operation Manual Table of Contents

	Page
Introduction	4
System Requirements	4
Bluetooth Receiver Lights	
Safety	4
Safety Decals	4
Bluetooth Operation	5-9
Downloading Hay App	5
Shutting Down the Hay App	6
Operation the Hay App	7
Device Selection	7
Demo Mode	8
Manual Selection	8
Recommended Preservative	8
Tab Descriptions	9
Screen Menus	10-13
Automatic Mode	10
Manual Mode	10
Setup Mode	11
Job Records	12
Software Versions	12
Baling Rate Settings	13
Automatic Mode	14
Manual Mode	15
Job Records	16
Wiring Diagram – 300RB	17
Wiring Diagram – 300RBC	18
Maintenance & Winter Storage	19
Common Questions	19
Troubleshooting	19
iPad Troubleshooting	20
Pin Outs	21-22
Parts Breakdown	23-26
Controls and Harnesses	23
End of Bale Sensor Kit	23
Moisture Pads	24
Optional iPad Mini Mounting Kit (030-2012MK)	25
Optional iPad Display Kit (030-2670DK)	26
Warranty Statement	27

Introduction

Congratulations and thank you for purchasing a Harvest Tec Model 300RB or 300RBC moisture only kit. Please read this manual carefully to ensure correct steps are taken to attach the system to the baler. This applicator is designed to read moisture through an Apple iPad. A parts break of the system is located in the back of the manual.

Right and Left sides are determined by facing in the direction of forward travel.

System Requirements

***Requirement to run iPad option are 3rd Generation iPad (2012) or newer running the current iOS operating system or one version previous required for iPad option.**

Bluetooth Receiver Lights

*New for production year 2018. All Bluetooth receivers (030-6672B) are now equipped with lights to indicated both power and iPad connection.

Blinking Lights – System is waiting for the processor to connect, which could take up to 35 seconds.

Red Light – The Bluetooth receiver has power

Green Light – When the proper active connection is selected in the Hay App menu, the green light will indicate connection with the iPad.



Safety

Carefully read all the safety signs in this manual and on the applicator before use. Keep signs clean and visible. Replace missing or damaged safety signs. Replacement signs are available from your local authorized dealer. See your installation manual under the replacement parts section for the correct part numbers.

Keep your applicator in proper working condition. Unauthorized modifications to the applicator may impair the function and/or safety of the machine.

Carefully read and understand all of the baler safety signs before installing or servicing the baler. Always use the supplied safety equipment on the baler to service the applicator.

Safety Decals

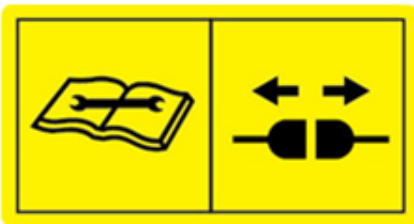

Number 1
Disconnect power before servicing.
Part no. DCL-8003



Number 2
Read and understand the operator's manual
before using or working around the equipment.
Part no. DCL-8000

Bluetooth Operation

Turn On / Off iPad using the Sleep/Wake button

*(Info from Apple User's Guide)

Turn iPad on. Hold down the Sleep/Wake button until Apple logo appears. iPad will take a moment to load.

You can lock iPad and put it to sleep when you're not using it. Locking iPad puts the display to sleep, saves the battery, and prevents anything from happening if you touch the screen.

Sleep/Wake Button



When you are not going to use the iPad for an extended period of time put the unit into sleep mode by pressing the Sleep/Wake button. Press Sleep/Wake button to wake iPad and then unlock iPad by entering passcode.

Turn iPad off. Hold down the Sleep/Wake button for a few seconds until the slider appears onscreen, then drag the slider to the right.

Downloading the Hay App

1. If iPad does not have Wi-Fi turned on, select the Settings tab  then select the Wi-Fi tab (below).

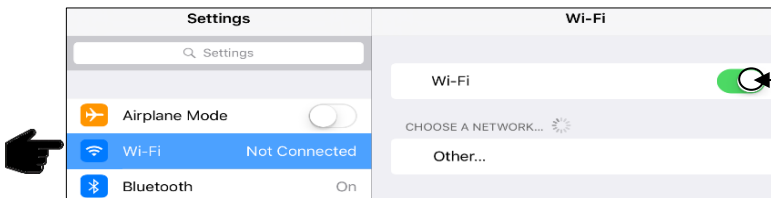

2. Turn Wi-Fi on by sliding button to the right. *Green bar indicates ON

3. Use same process to turn on Bluetooth function

4. Select an available network when detected by the iPad, shown in area above that currently says 'Other'.

5. Select App Store icon (below) and open. *You will need a Wi-Fi connection available to view App Store.



****The Harvest Tec system WILL NOT appear under the Bluetooth tab in the Setting App. Open the Hay App to connect.**

Download the Hay App in the App Store by searching for 'Hay App' in the search bar in the top right corner of screen (right):

*The advertisements displayed on the App Store screen will change.

The app will have the icon as shown:



Hay App

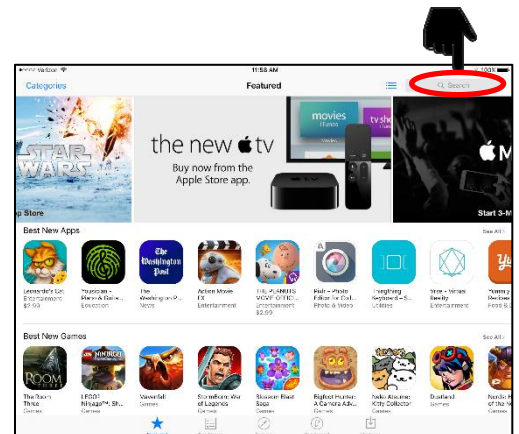

Note: Operation requires iPad Mini or iPad 3rd Generation (2012) or newer, running the current iOS operating system or one version previous required for iPad option.

Shutting Down the Hay App

1. To shut down the Hay App double click the home button (Figure A). This will show the open apps that are running on your iPad (Figure B).

*Note: By pressing the home button one time to return to the home screen, the Hay App **does not** shut down. The system will however, stop applying preservative after 10 seconds.



Figure A

2. Slide the app you want to shut down by sliding the app toward the top of the iPad, until the app is no longer visible (Figure C).



Figure B

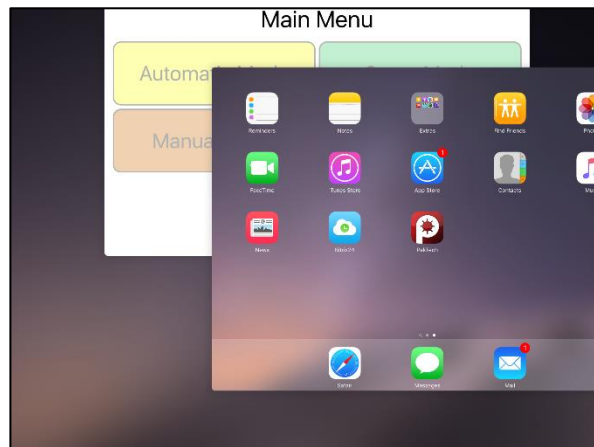

Figure C

Operating the Harvest Tec iPad App (continued)

When ready to operate your applicator system, open the Hay App on the iPad by selecting the Hay App icon.

**Use the following information for Round Balers.*

Device Selection

The app will open to the Device Menu screen as shown below. Applicators which are equipped with the Bluetooth receiver that are within range (20') of the iPad and have power going to them, will be shown under the Active Connections section.

After the iPad connects to the Bluetooth receiver, select the applicator you want to connect with.

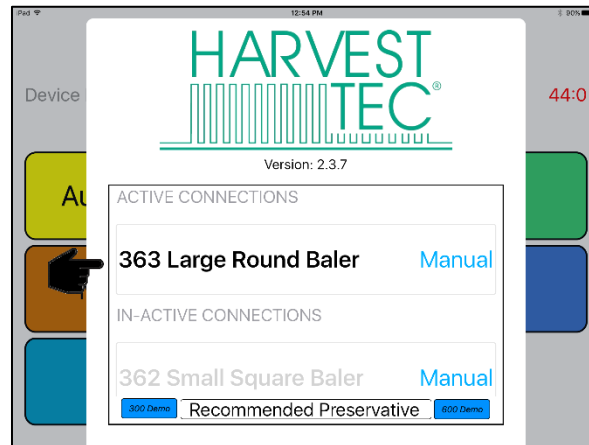

The In-Active Connections section will show the applicator systems that once were connected, that are not within range of the iPad or do not currently have power going to them (bottom left).

To remove a baler from the In-Active list, slide the bar displaying the baler name to the left, and select the Delete button that will appear (bottom right).

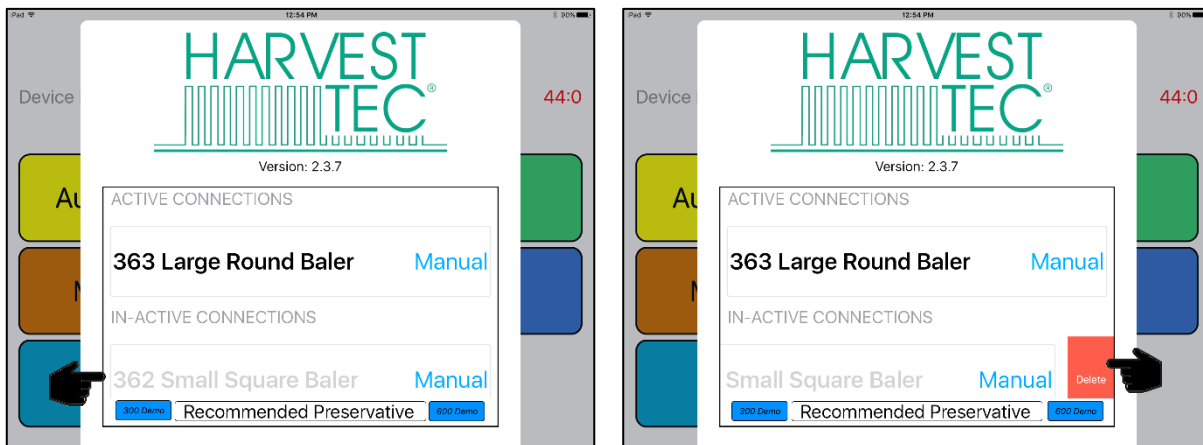

Operating the Harvest Tec iPad App (continued)

Demo Mode

Selecting the 300 Demo or 600 Demo button (below) will allow you to view the different screens of the applicator without requiring connection to an applicator system.

*This function is intended to be used as a visual aid, no values will be displayed.

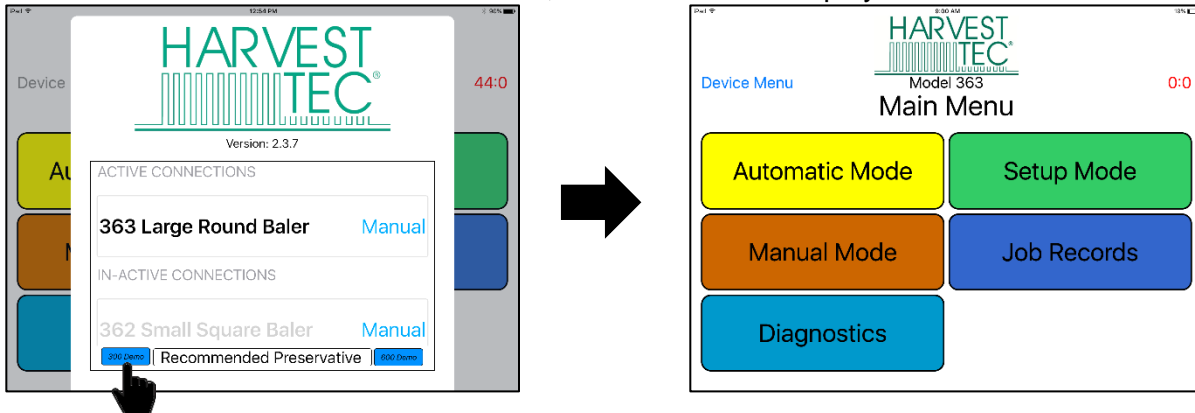

Manual Selection

Selecting the Manual button (below) displayed to the right of the baler name will open the operation manual for your baler.

*You do not need to be connected to a baler to open the manual and recommended preservative tabs after a baler has been connected.

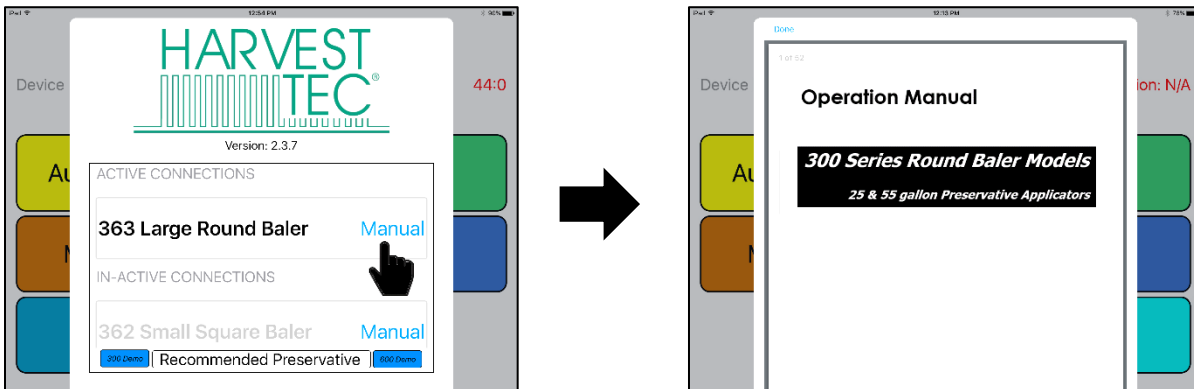

Recommended Preservative

To view recommended preservative information, application rates, and frequently asked preservative questions, select Recommended Preservative (below).

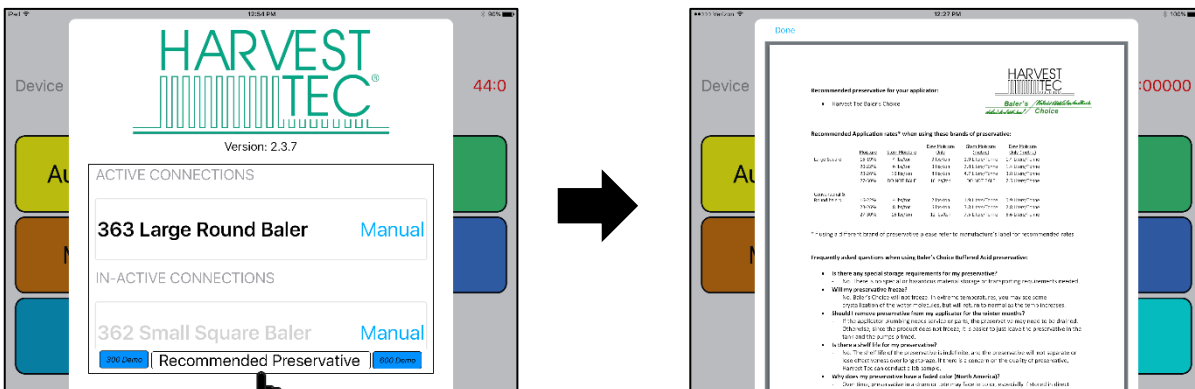

Operating the Harvest Tec iPad App (continued)

Once you have selected the baler you want to connect with from the Device Menu, the applicator main menu will display (below).

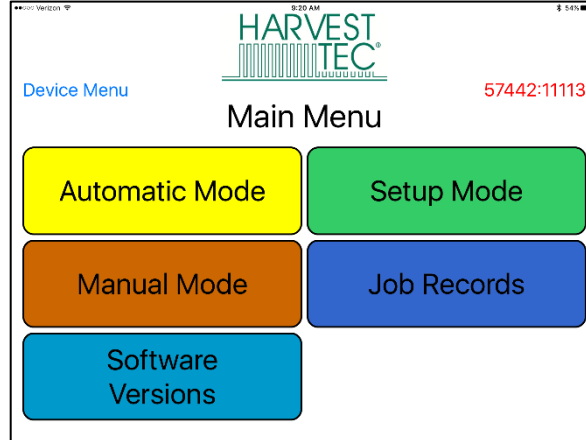

Tab Descriptions

Automatic Mode: This mode allows you to use all of the applicator features such as adjusting preservative application on the go and counting total pounds of product used.

Manual Mode: Allows operator to manually turn pumps on and off. This mode also has moisture content displayed. Use this mode to prime pump.

Software Versions: Selecting this tab will display the software currently installed.

Setup Mode: This mode allows the operator to adjust bale rate, application rate settings and select tip output.

Job Records: Keep track of up to 300 jobs with total product used, average moisture content, tons baled, and baling date.

Screen Menus

Use the screen shots below to navigate through the operation screens.

Automatic Mode

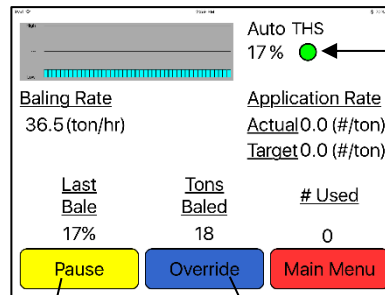
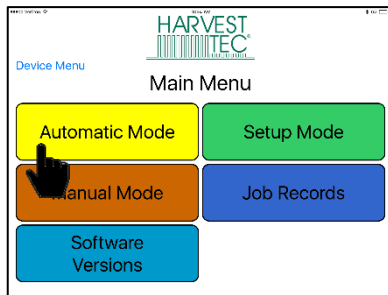

Bluetooth Connection Indicator
 Green -TMS is connected
 Yellow -TMS connecting
 Red -TMS not connected
 *Actual, Target, and # Used will read 0 with moisture only system

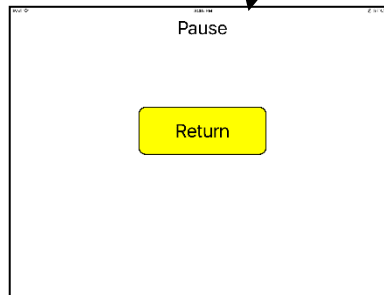

Manual Mode

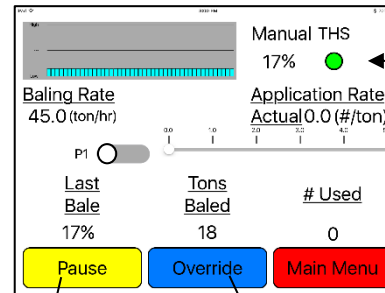
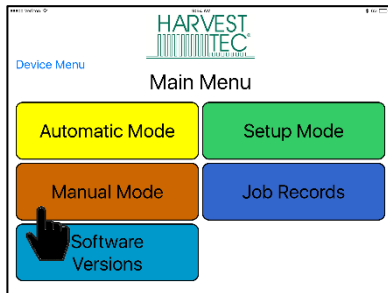

Bluetooth Connection Indicator
 Green -TMS is connected
 Yellow -TMS connecting
 Red -TMS not connected
 X -Pump is OFF
 ✓ -Pump is ON
 *Ensure pumps are shut off with moisture only system

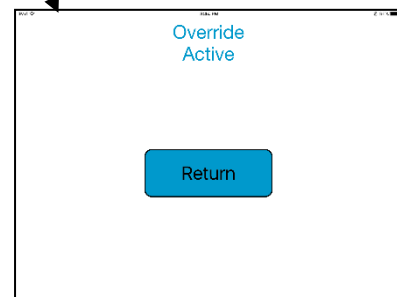
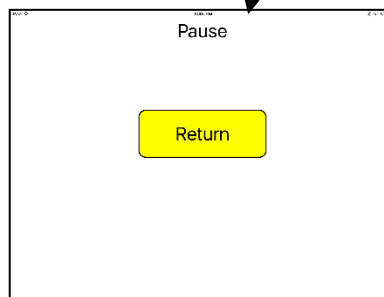

Operation Note:

Pressing the Home Button on the iPad **WILL NOT** immediately stop reading moisture.

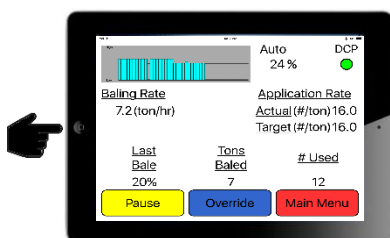

Select **Pause** or **Main Menu** to stop.

*Pressing the home button will cause the system to stop reading moisture after 10 seconds.

Setup Mode

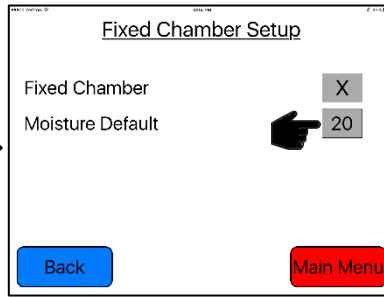
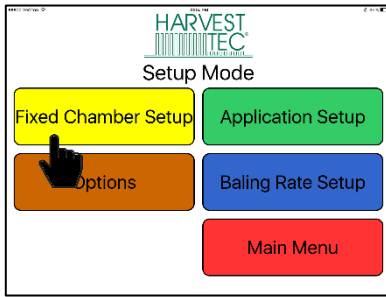
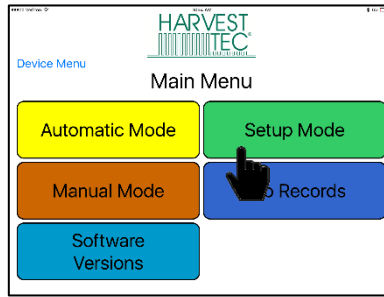

If using a fixed chamber baler, select the X to turn on

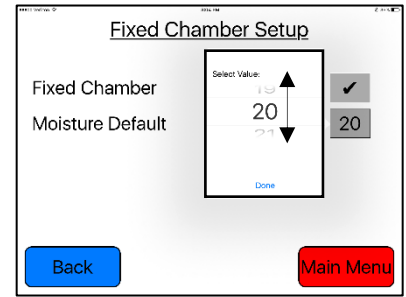

Adjust the moisture default to the moisture of the last bale reading

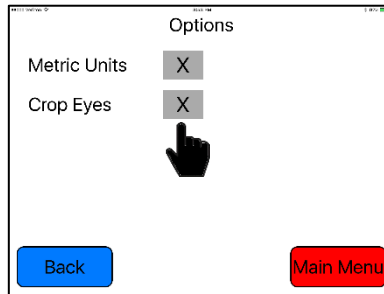
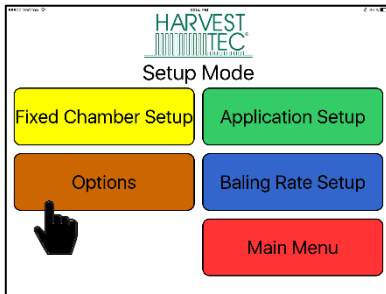

*Select X to turn on options shown

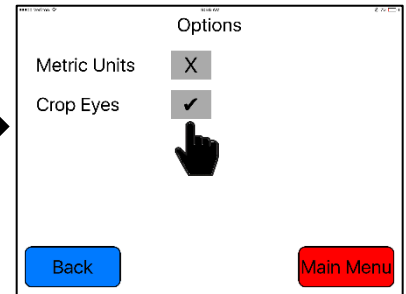

✓ Indicates Crop Eyes are ON

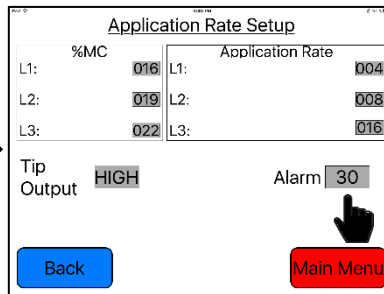
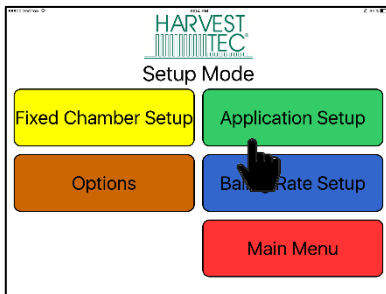

Adjust moisture alarm to desired level

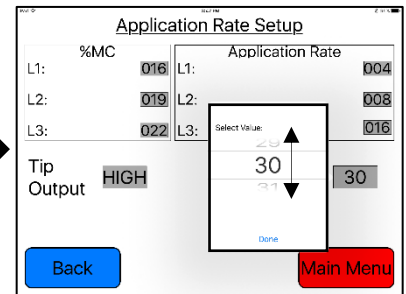

Select desired alarm moisture

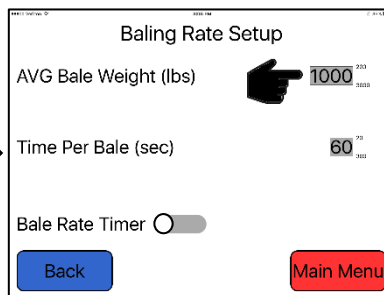
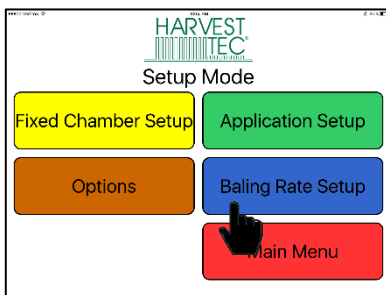

Adjust bale weight information

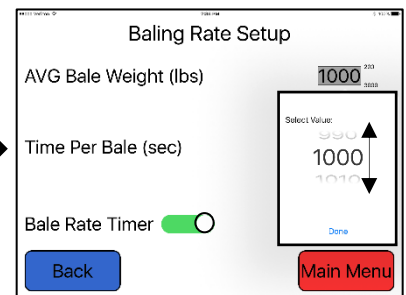

Select desired bale weight

Job Records

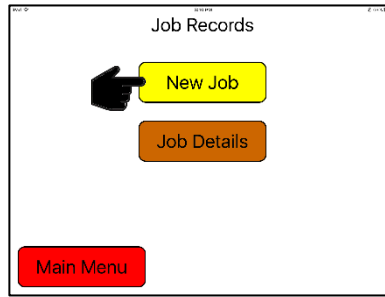
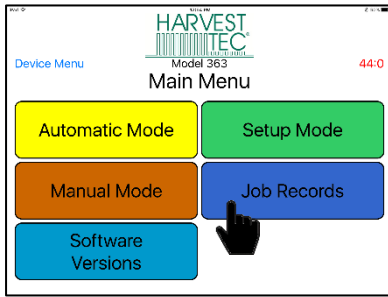

Select New Job to create new job

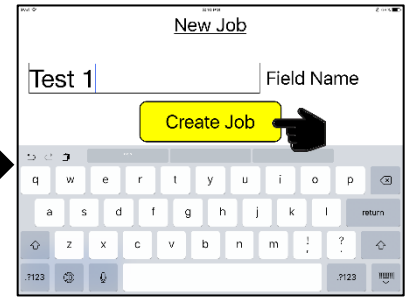

Type in Field Name, press Create Job

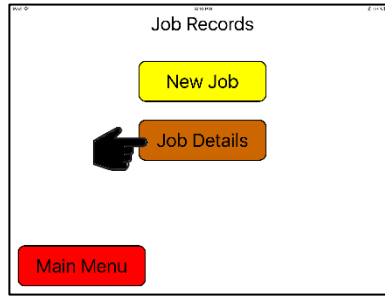
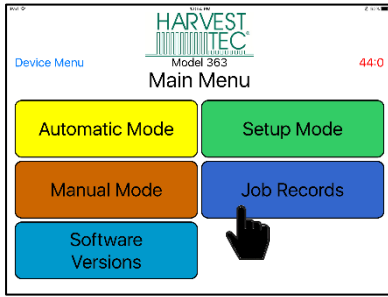

Select Job Details to view job records

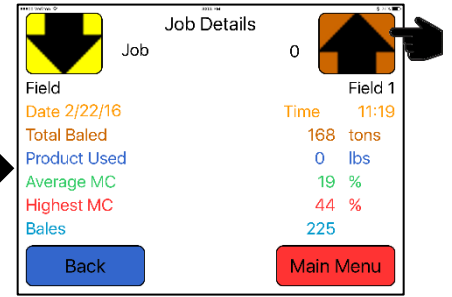

Select the Up and Down arrows to view different jobs

Software Versions

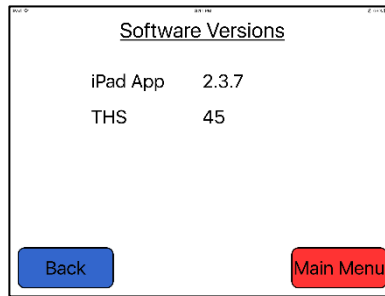
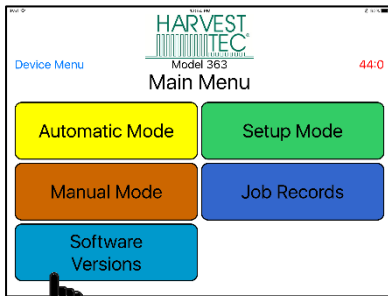

*This is an example, Software Versions will change

Baling Rate Settings – Round Balers

iPad Operation

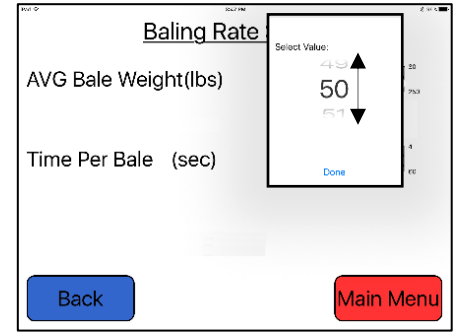
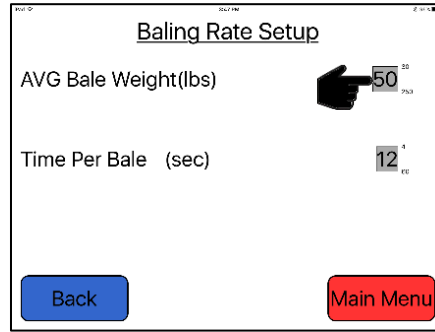
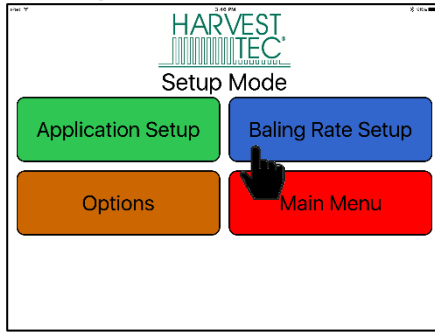

1. On the setup mode screen press the BALING RATE key.
2. Press the grey number value to the right of AVG Bale Weight (Lbs). To adjust the weight of your bales, the scroll tool shown on the right will display. Scroll through the values to select correct information, press DONE when value has been selected. The information will be saved until updated. Use the same procedure for adjusting time per bale.
Note: Only count time that hay is coming into the baler, do not count tie time or drive time.
3. Press the BACK key found on the bottom left hand figure of the screen to return to SETUP MODE screen or press the MAIN MENU key to return to the opening screen.

Operation Instructions

Automatic mode will allow you to view the moisture information and baling rate.

Automatic Mode

After pushing the AUTOMATIC MODE key in the Main Menu screen, the following screen will appear:

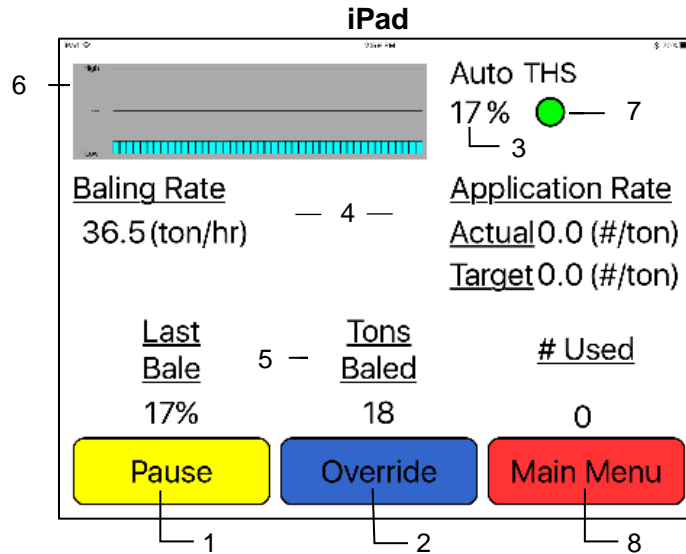

1. To pause the unit while in operation select the Pause key.
2. Push the OVERRIDE key to turn on the pump for full output of the system. This button is not used with a moisture only system.
3. The moisture content is shown in the upper right hand corner.
4. Baling Rate and Application Rate are shown in the middle of the screen. Application rate will read zero with moisture only systems.
5. Volume of preservative used will be shown at the bottom of the screen will show accumulated pounds of preservative used on the go. There will not be any information shown in the # Used section with a moisture only unit.
6. The graph shows the moisture trend from the past 90 seconds in 3 second intervals.
7. The iPad button shown when using an iPad displays your connection signal with Bluetooth receiver. Green – iPad is connected, Yellow – iPad is connecting, Red – iPad not connected.
8. Press the MAIN MENU key to return to the opening screen.

Manual Mode

After pushing the MANUAL MODE key in the Main Menu screen, the following screen will appear:

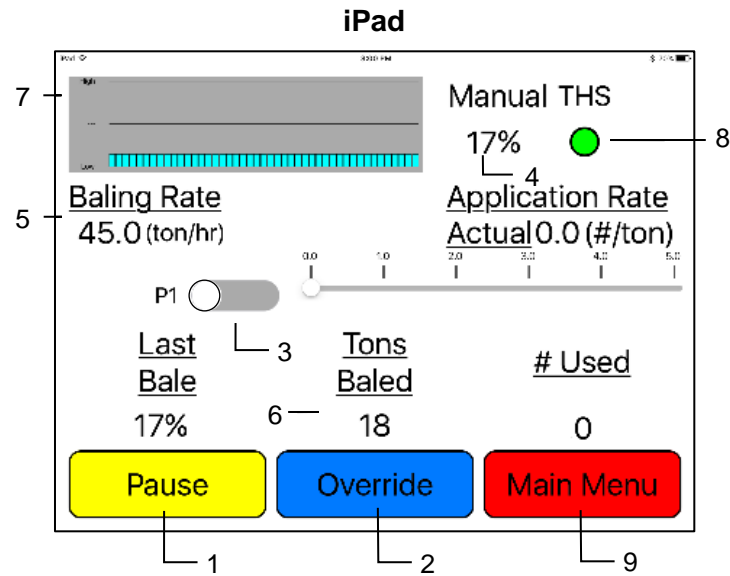

1. To pause the unit during operation select the Pause key.
2. Push the OVERRIDE key to turn on the pump for full output of the system. This function is not used with a moisture only unit.
3. Ensure the pump is off with a moisture only unit. Grey bar indicates the pump is off.
4. The moisture content is shown in the upper right hand corner.
5. Baling rate and Application rate are shown in the middle of the screen. The Actual reading will read zero with a moisture only unit.
6. Volume used shown at the bottom of the screen will show accumulated pounds of preservative used on the go. This number will reset at power down, but remains in the job record screen. # Used will read zero with moisture only unit.
7. The graph in the upper left corner shows the moisture trend from the last 90 seconds of baling (one every 3 seconds).
8. The iPad button shown displays your connection signal with Bluetooth receiver. Green – iPad is connected, Yellow – iPad is connecting, Red – iPad not connected.
9. Pressing MAIN MENU will return you to the opening screen.

Job Records

After pushing the JOB RECORDS key in the Main Menu screen, the following screen will appear:

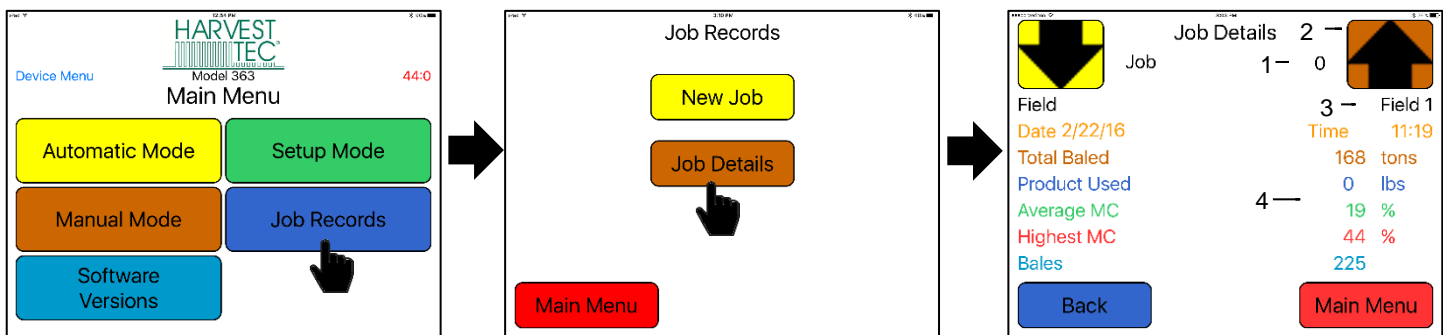

1. The job number will be displayed at the top center. The current job being viewed will always read "Job #: 0". Product used and average moisture content will be reset when the NEW JOB key is pressed. The job records screen will store up to 300 jobs allowing access previous jobs by using the up and down arrows.
2. Scrolling through previous jobs is done by pressing the UP or Down keys.
3. The field name is located under the up arrow.
4. The accumulated information from the field will be displayed in the middle of the screen. **Every time the NEW JOB key is pressed the accumulated pounds on auto and manual modes will be reset to zero.** After 300 jobs have been stored, the next time the NEW JOB key is pressed the system will start over with job one and the old job will be replaced.

NOTE: Initial start-up requires pressing the New Job key in the Job Records screen in order for Volume Used accumulation to be recorded. This only needs to be done once on initial start-up of system and not every time the system is started for operation.

Wiring Diagram – 300RB

1. Connect the power harness (006-3650T) to the tractor battery (12 volt) using the red wire with fuse to the positive side and the black wire to the negative.
 - a. **The power harness must be connected to the battery!** The unit will draw more amps than convenience outlets can handle. Any modifications of the power harness will void systems warranty. **CONTACT HARVEST TEC BEFORE MODIFICATIONS.**
 - b. **This unit will not function on positive ground tractors.**
 - c. **If the unit loses power while operating it will not keep track of accumulated pounds of product used.**
2. The power harness on the tractor (006-3650T) will run from the tractor battery to the hitch. The power harness on the baler (006-3650B1) will connect to the tractor power harness (006-3650T) at the hitch.
3. Connect the keyed power wire (006-5650K) to a keyed power source on the tractor. **The keyed power wire must connect to a keyed source or the unit will not power up correctly.**
4. Attached the Bluetooth Receiver (030-6672B) to the tractor power harness (006-3650T). Mount the Bluetooth receiver in a safe location as close to iPad as possible in cab.
5. Attach the End of Bale (EOB) connection on the controller to the End of Baler Sensor (006-7400).



System wiring diagram

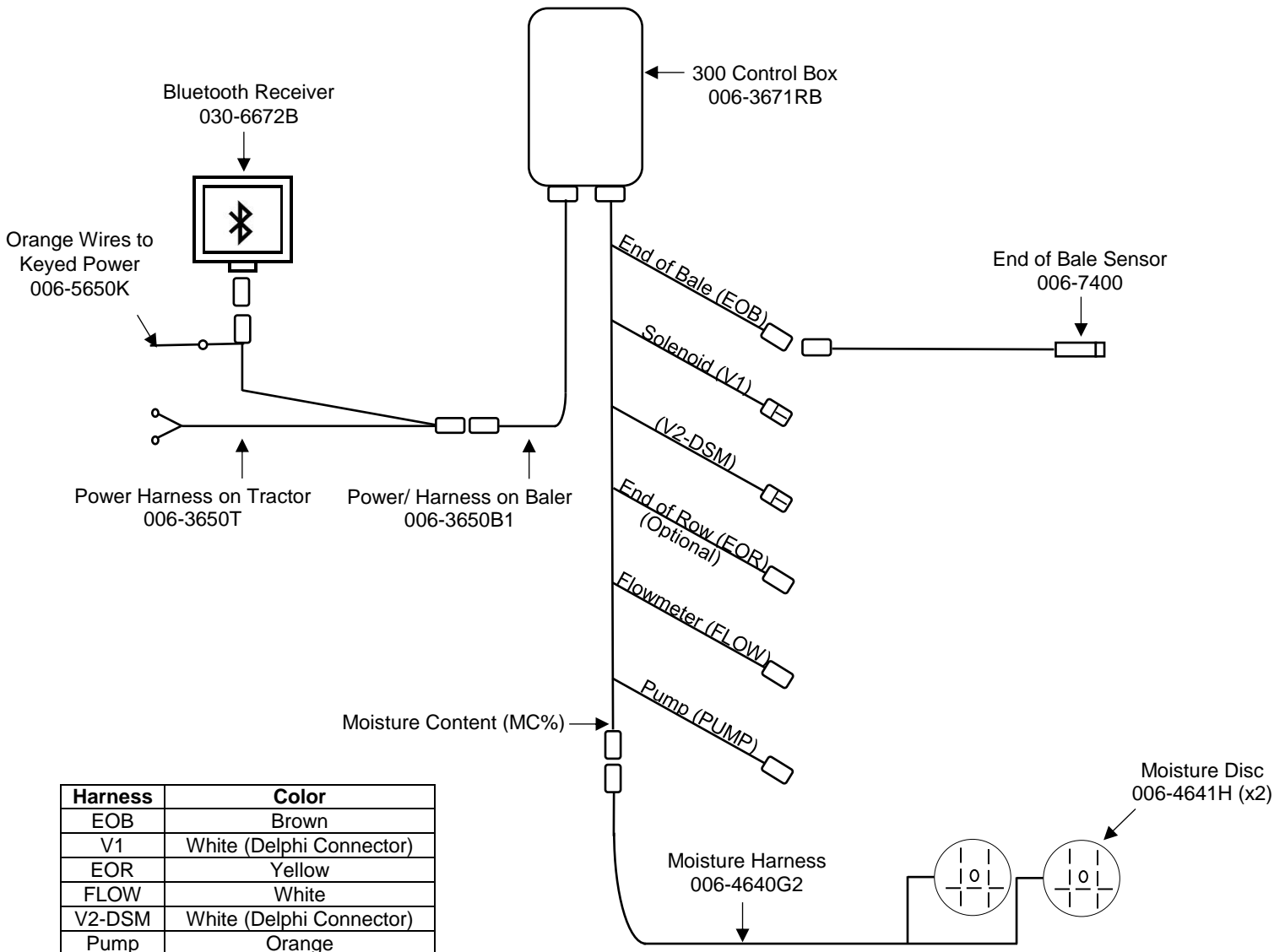

Wiring Diagram – 300RBC

1. Connect the power harness (006-3650T) to the tractor battery (12 volt) using the red wire with fuse to the positive side and the black wire to the negative.



- a. **The power harness must be connected to the battery!** The unit will draw more amps than convenience outlets can handle. Any modifications of the power harness will void systems warranty. **CONTACT HARVEST TEC BEFORE MODIFICATIONS.**
- b. **This unit will not function on positive ground tractors.**
- c. **If the unit loses power while operating it will not keep track of accumulated pounds of product used.**

2. The power harness on the tractor (006-3650T) will run from the tractor battery to the hitch. The power harness on the baler (006-3650B1) will connect to the tractor power harness (006-3650T) at the hitch.
3. Connect the keyed power wire (006-5650K) to a keyed power source on the tractor. **The keyed power wire must connect to a keyed source or the unit will not power up correctly.**
4. Attached the Bluetooth Receiver (030-6672B) to the tractor power harness (006-3650T). Mount the Bluetooth receiver in a safe location as close to iPad as possible in cab.
5. Attach the End of Bale (EOB) connection on the controller to the End of Baler Sensor (006-7400).

System wiring diagram

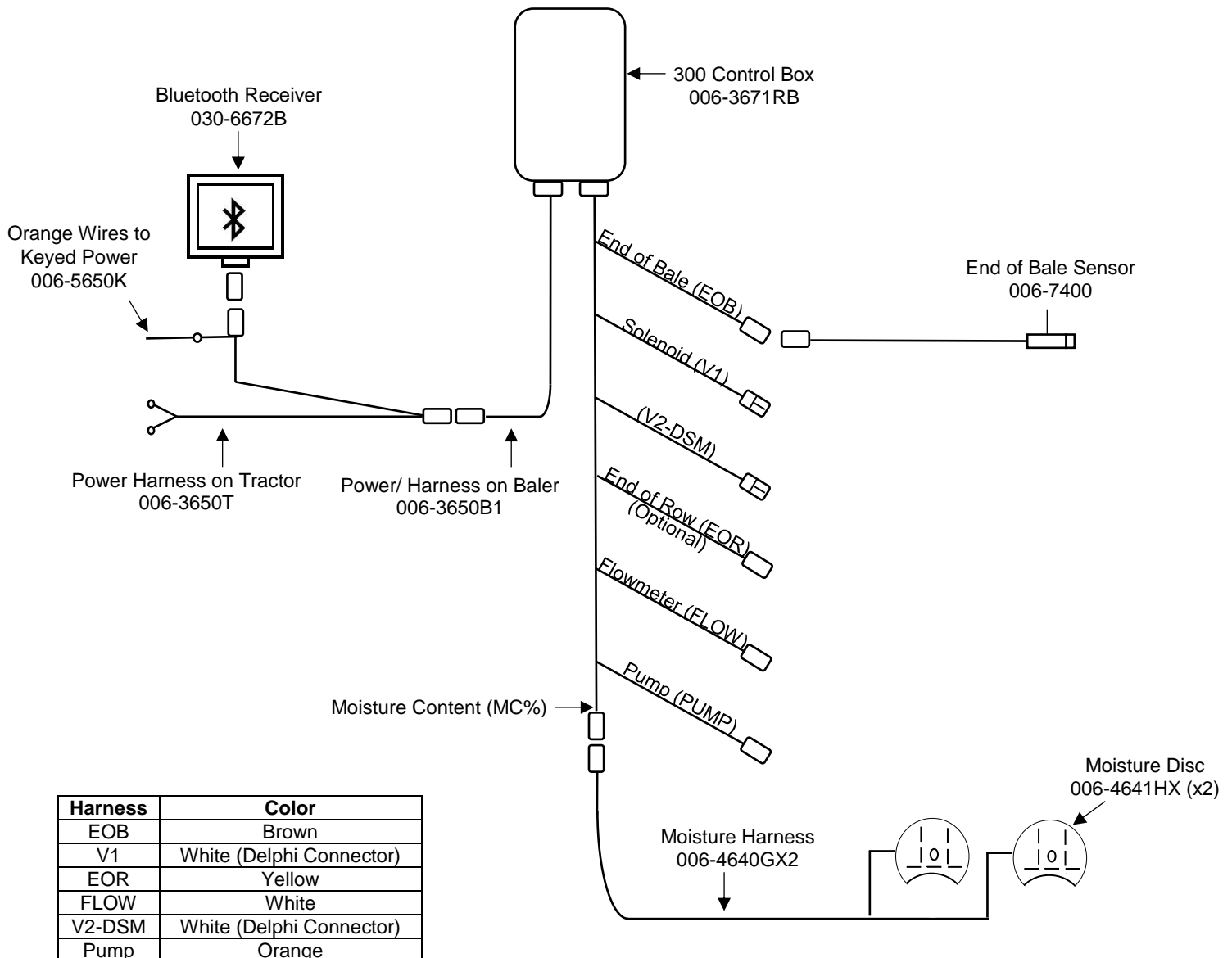

Maintenance

Dielectric Grease Connections: Disconnect all harnesses on the applicator, clean the connections, and repack with dielectric grease.

Battery Connections: Follow the batteries safety warnings and clean the battery connections. If the connections cannot be cleaned, replace harness.

Winter Storage

Disconnect power from the Three Hundred Series controller (THS).

Common Questions

1. How do I turn the system on/off?

To turn the system ON open the Hay App and select the active system for the baler you are using.

2. The moisture content displays “LO” or “HI” all the time.

When the moisture content display does not change frequently while baling, there is likely a faulty moisture disc connection. Check if there is build up around the moisture discs and for grounding between the disc and the bale chamber. Also, check all moisture disc wires and connectors to see if there is a continuity.

3. Should the battery connections be removed before jump starting or charging a battery?

Yes. Anytime the tractor will have voltage going up rapidly the connections should be removed.

4. What is the expected battery life of the iPad when baling?

3.5 hours is the expected amount of time for the battery when continuously baling. Shut off all other applications, wireless internet, and Wi-Fi signal to reduce the amount of programs iPad is running. It is recommended to use an accessory outlet charger when operating (not included with iPad).

*Note: Not all chargers are designed to charge an iPad, verify before purchasing.

5. What is the max distance for connection between the iPad and the Bluetooth Receiver?

The range for the connection will depend on the amount of equipment (tractor, baler, ect.) between the two devices. The max distance will range between 10' – 20'.

6. What do the lights on the 030-6672B indicate?

Red Light – The Bluetooth receiver has power. *Green Light* – When the proper active connection is selected in the Hay App menu, the green light will indicate connection with the iPad.

Troubleshooting

Problem	Possible cause(s)	Solution(s)
Moisture reading errors (reading high or low)	1. Wire disconnected or bad connection	1. Reconnect wire.
	2. Low power supply to THS	2. Check voltage at box. Min of 12V
	3. Hay over 60% moisture	
	4. Ground contact with one or both moisture disc and THS	4. Reconnect.
	5. Short in wire between moisture	5. Replace wire.
Moisture Reading Erratic	1. Check all wiring connections for corrosion or poor contact.	1. Apply dielectric grease to all connections.
	2. Check power supply at tractor. Voltage 12V-14V	2. Install voltage surge protection on tractors alternator.
Bluetooth Receiver lights will not illuminate	1. Bluetooth receiver not connected 2. Harness disconnected 3. Low power	1. Check connections and voltage. Minimum 12.5V needed.
	<i>Red Light</i> – The Bluetooth receiver has power <i>Green Light</i> – When the proper active connection is selected in the Hay App menu, the green light will indicate connection with the iPad.	

iPad Troubleshooting

<u>iPad Symptom</u>	<u>Troubleshooting</u>
iPad won't turn on	-Turn your iPad off and on. Press and hold the Sleep/Wake button for a few seconds until a red slider appears; then slide it. Press and hold the Sleep/Wake button to turn on again.
	-Reset your iPad. Press the "Sleep/Wake" button and the "Home" button simultaneously for at least 10 seconds until the Apple logo appears on the screen. This reset will not damage your files.
	-Battery may be drained. Plug iPad into your computer or AC adapter and see if anything happens. The iPad will recognize it has been connected to a power source and charge its battery. If it will no longer charge, the battery must be swapped with a replacement battery. Battery level displays in top right corner of iPad.
Cannot get an active baler connection	-Make sure that your Bluetooth accessory and iOS device are close to each other when connecting.
	-Make sure that your Bluetooth accessory is on and fully charged or connected to power. If it uses batteries, test them to see if they need to be replaced.
	-Restart your Bluetooth receiver, by removing power and reconnecting after 30 seconds.
	-Make sure that you have at least a 3 rd generation iPad with iOS8 or greater operating system on your iPad
	-On your iPad, go to Settings > Bluetooth and make sure that Bluetooth is on. If you can't turn Bluetooth on or you see a spinning gear, restart your iPad
	-Unpair the Bluetooth accessory, put the accessory back in discovery mode, then pair and connect it again. By tapping on its name in the Bluetooth accessories tab and then Forget this Device. In settings, tap on a device's name, then Unpair.
	-Display connector plug and bale rate sensors plug are switched on THS. Switch connections.
	-Short in display cable. Replace the cable.
iPad touchscreen is slow or does not respond	-Screen may be dirty. Clean screen. Unplug everything, turn off iPad and with soft, lint-free, slightly damp cloth gently wipe screen. Do NOT use window cleaners and paper towels.
	-If you have a screen protector sheet, try removing it.
iPad is not charging or is slow to charge	-In order to charge your iPad you can try either connecting your iPad to a power outlet or connecting to a USB 2.0 port on a computer. However, note that computers generally don't supply enough power to their USB ports to be able to charge an iPad. When this happens, a "Not Charging" message will appear.
How can I unlock my iPad if I forgot the passcode	-If you cannot remember the passcode, you will need to <i>restore your device using the computer with which you last synced</i> . This allows you to reset your passcode and resync the data from the device (or restore from a backup). If you restore on a different computer that was never synced with the device, you will be able to unlock the device for use and remove the passcode, but <i>your data will not be present</i> .
How do I send in my iPad for service?	-Refer to your iPad owner's manual or contact Apple. DO NOT SEND iPad TO HARVEST TEC.
For other issues refer to your iPad Owner's Manual or contact Apple Directly	

Harvest Tec Does Not Service iPads

Pin Outs

Power Harness 006-3650T at Tractor Hitch

Pin 1	Red	+12V Power to BLE
Pin 2	Red	+12V Power to THS
Pin 3	Orange	Keyed Power
Pin 4	Not Used	
Pin 5	Green	HT Can Low
Pin 6	Yellow	HT Can Hi
Pin 7	Not Used	
Pin 8	Black	Ground from BLE
Pin 9	Black	Ground from THS
Pin 10	Not Used	



Power Harness 006-3650B1 at Baler Hitch

Pin 1	Red	+12V Power to BLE
Pin 2	Red	+12V Power to THS
Pin 3	Orange	Keyed Power
Pin 4	Not Used	
Pin 5	Green	HT Can Low
Pin 6	Yellow	HT Can Hi
Pin 7	Not Used	
Pin 8	Black	Ground from BLE
Pin 9	Black	Ground from THS
Pin 10	Not Used	

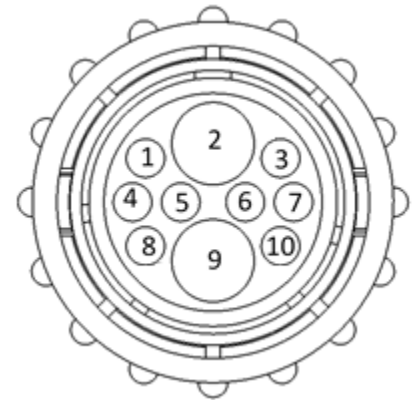

Bluetooth Receiver on Harness 006-3650T

Pin 1	Red	+12V Power for BLE
Pin 2	Black	Ground for BLE
Pin 3	Yellow	HT Can Low
Pin 4	Not Used	
Pin 5	Green	HT Can Hi
Pin 6	Not Used	
Pin 7	Not Used	

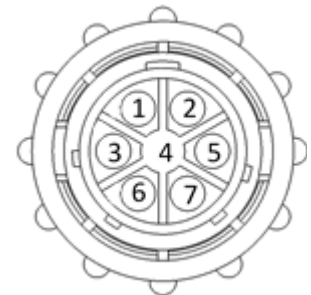

End of Bale Sensor at 300 Controller Harness

Pin 1	Brown	Sensor Power
Pin 2	Blue	Sensor Ground
Pin 3	N/A	
Pin 4	Black	Signal from Sensor

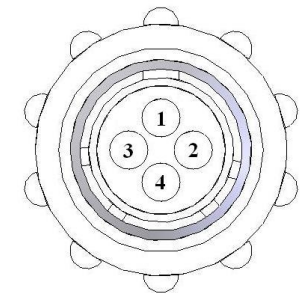

Flow Meter at 300 Controller Harness

Pin 1	White	+5-12V Power
Pin 2	Brown	Ground
Pin 3	Green	Signal
Pin 4	Not Used	

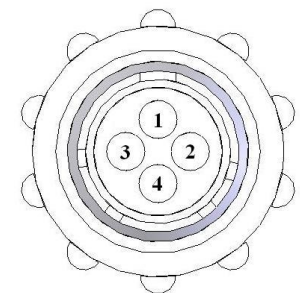

Pin Outs (continued)

End of Row Sensor at 300 Controller Harness

Pin 1	Red/White	+12V Power
Pin 2	Black/White	Ground
Pin 3	Yellow	Signal
Pin 4	N/A	

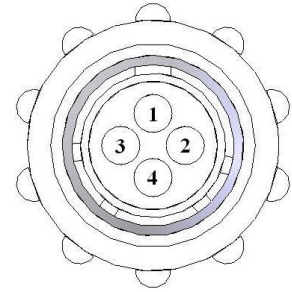

Moisture Sensor connection at 300 Controller Harness

Pin 1	Not Used	
Pin 2	Not Used	
Pin 3	Not Used	
Pin 4	Not Used	
Pin 5	Not Used	
Pin 6	Not Used	
Pin 7	Not Used	
Pin 8	Blue	Signal for Sensor 1
Pin 9	Blue	Signal for Sensor 2

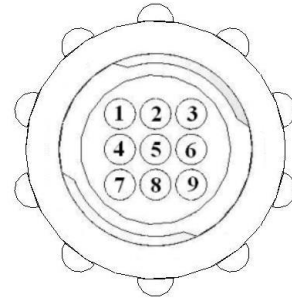

Pump connection at 300 Controller Harness

Pin 1	Red	Power to Pump
Pin 2	Black	Ground to Pump

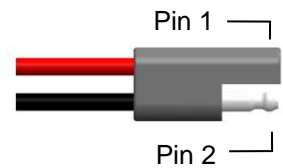

Solenoid Connection at 300 Controller Harness

Pin A	Black	Solenoid Pause
Pin B	White	Solenoid Ground

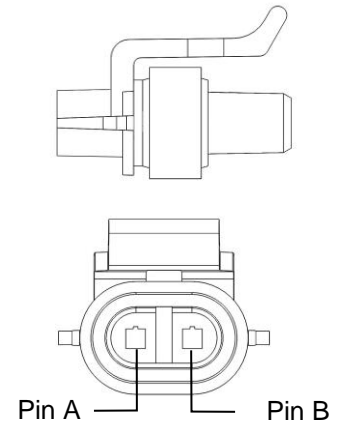

V2-DSM Connection at 300 Controller Harness

Pin A	Black	Solenoid Pause
Pin B	White	Solenoid Ground

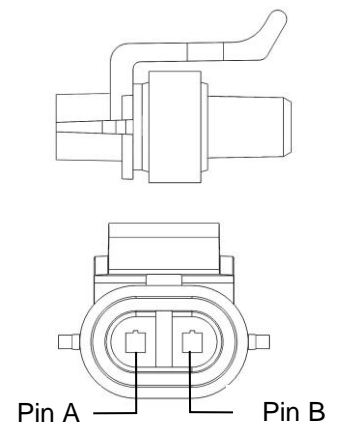

Control Box and Wiring Harnesses

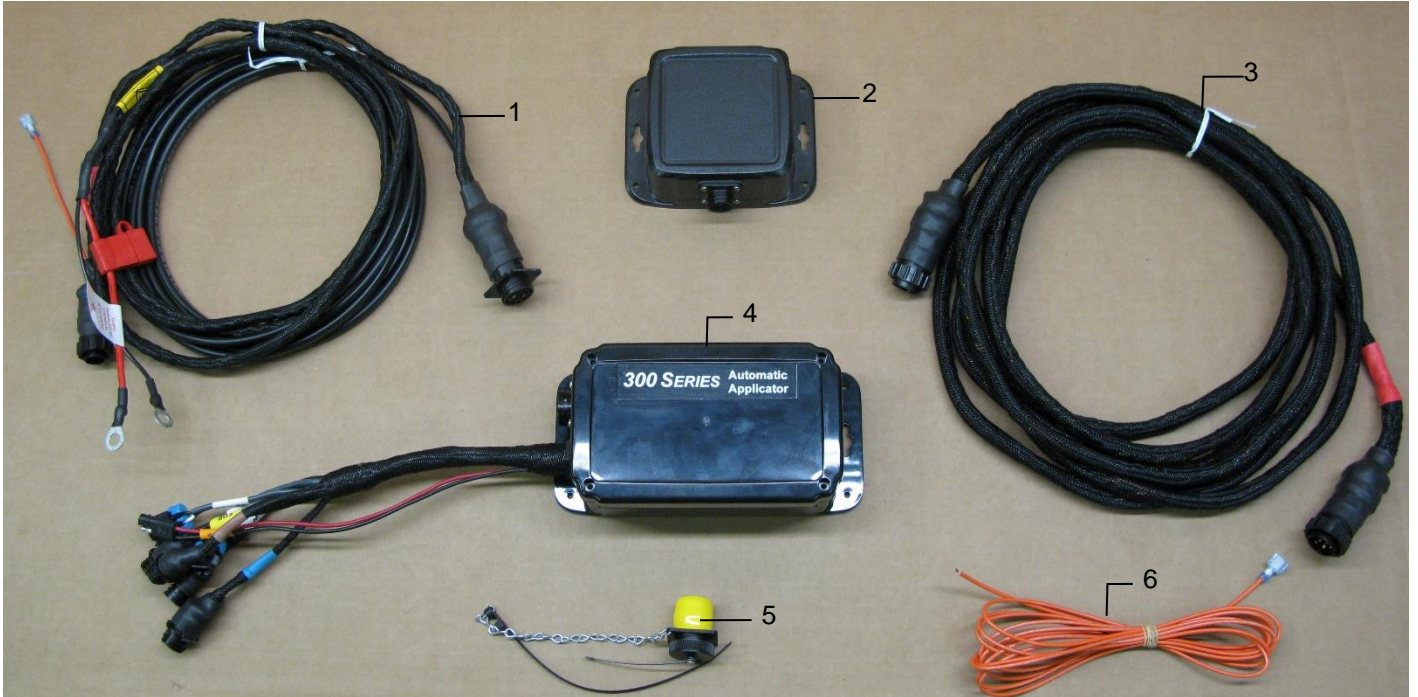

<u>Ref</u>	<u>Description</u>	<u>Part #</u>	<u>Qty</u>
1	Tractor Power Harness	006-3650T	1
2	Bluetooth Receiver	006-6672	1
3	Baler Power Harness (20')	006-3650B1	1
4	Control Box	006-3671RB	1
5	Dust Plug Kit	006-5651Plug	1
6	Key Switch Harness	006-5650K	1
Complete Assembly		030-363CPA	

End of Bale Sensor Kit A

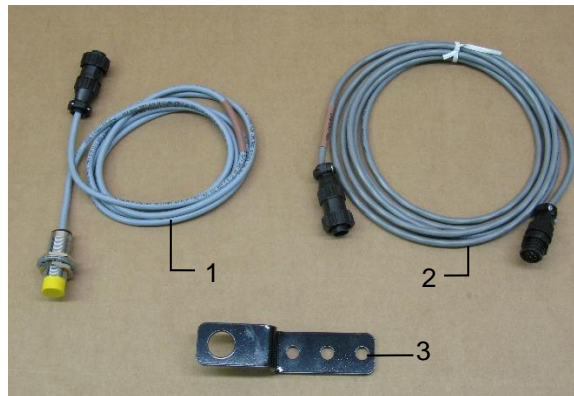

<u>Ref</u>	<u>Description</u>	<u>Part #</u>	<u>Qty</u>
1	End of Bale Sensor	006-7400	1
2	EOB Extension	006-7400EXT	1
3	End of Bale Bracket	001-4648RB	1
Complete Assembly		EOB-RB-A	

Moisture Sensors – 300RB

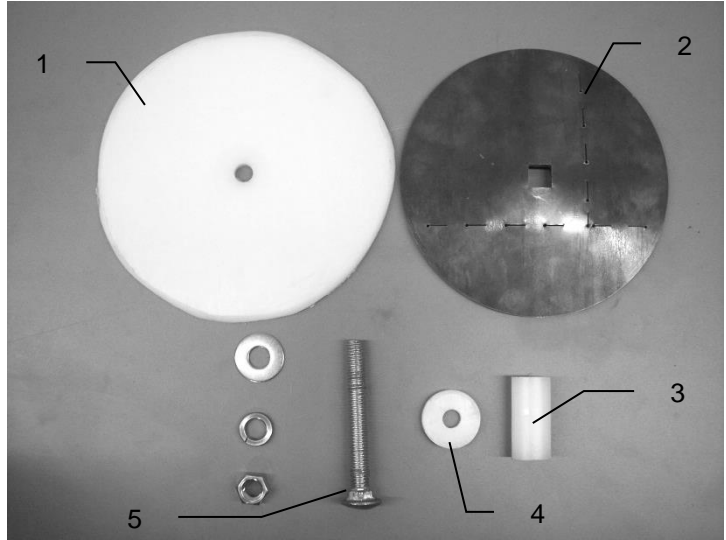

<u>Ref</u>	<u>Description</u>	<u>Part #</u>	<u>Qty</u>	<u>Ref</u>	<u>Description</u>	<u>Part #</u>	<u>Qty</u>
1	Plastic Pad	006-4641F	2	4	Plastic Isolator	006-4641I	2
2	Moisture Disc	006-4641H	2	5	1/2X4 1/2" Carriage Bolt		2
3	Plastic Bushing	006-4641G	2	6	Moisture Cable	006-4640G2	1
Moisture Pad Assembly (Ref 1-5)						030-4643	2
Complete Assembly (Ref 1-6)						MSH-RB-A	

Moisture Sensor – 300RBC

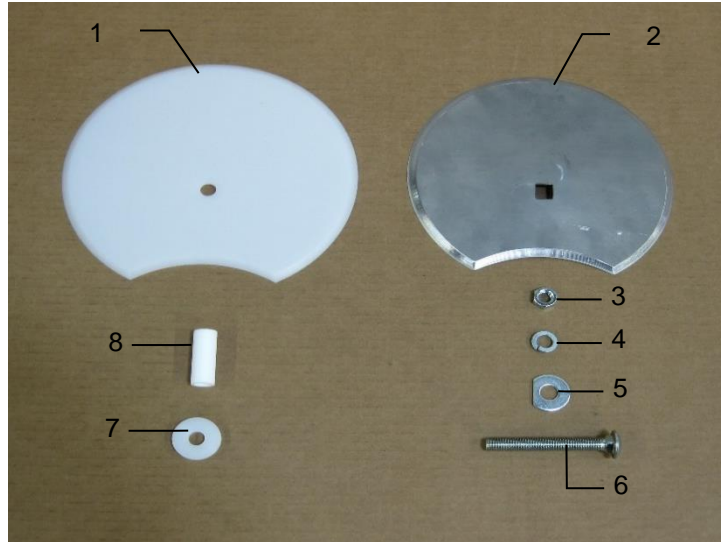
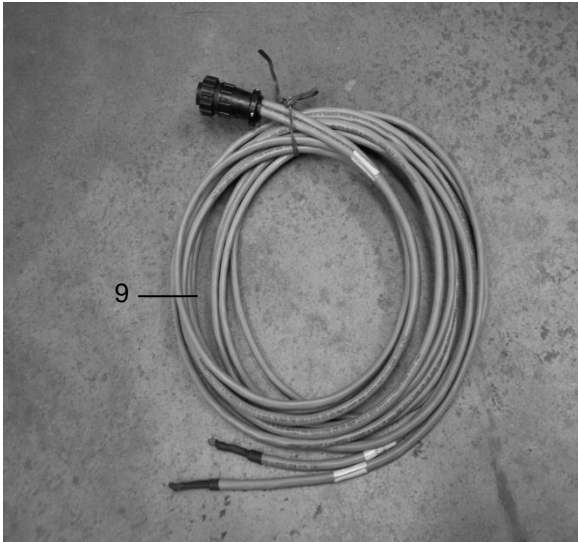

<u>Ref</u>	<u>Description</u>	<u>Part #</u>	<u>Qty</u>	<u>Ref</u>	<u>Description</u>	<u>Part #</u>	<u>Qty</u>
1	RB Isolator	006-4641FX	2	6	1/2" x 4 1/2" Carriage Bolt	Hardware	2
2	RB Moisture Pad	006-4641HX	2	7	Sensor Bushing	006-4641G	2
3	1/2" Nut	Hardware	4	8	Plastic Isolator	006-4641I	2
4	1/2" Lock	Hardware	4	9	Moisture Cable	006-4640GX2	1
5	1/2" D Washer	Hardware	6	Moisture Assembly (Ref 1-8)		030-4643C	2
Complete Assembly (Ref 1-9)						MSH-RB-C	

Optional iPad Mini Mounting Kit (030-2014MK)

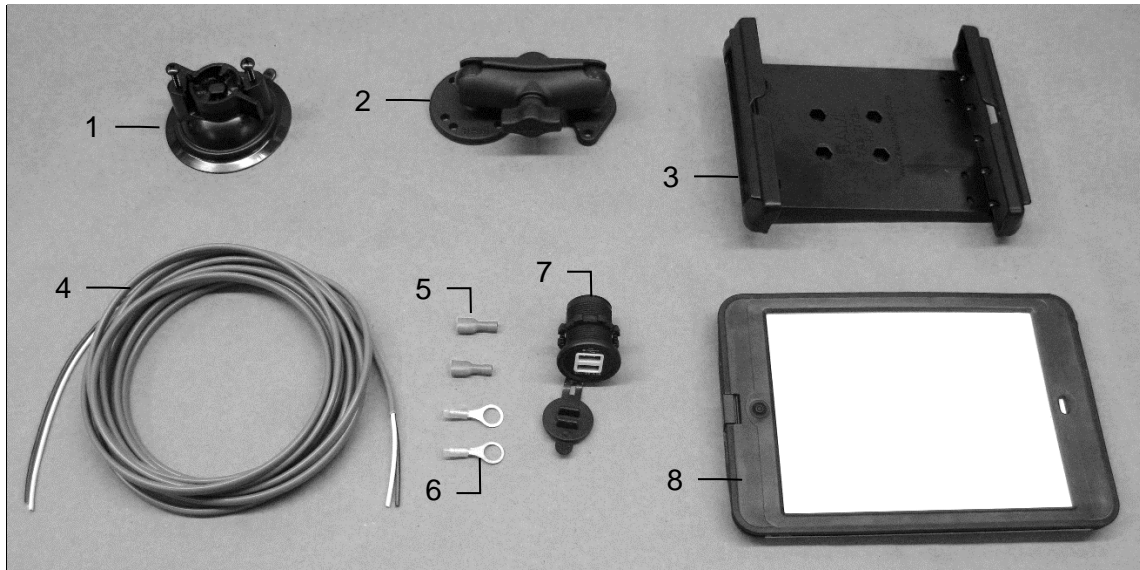

<u>Ref</u>	<u>Description</u>	<u>Part #</u>	<u>Qty</u>
1	Suction cup mount	001-2012SCM	1
2	Ram mount	001-2012H	1
3	iPad Mini spring load cradle (Mini 1,2,3)	001-2012SLC	1
4	16 gauge power wire	006-4723P	1
5	Female spade connector	Hardware	2
6	Eye loop connector	Hardware	2
7	iPad Mini Charger 12V	001-2012P	1
8	iPad Mini 4 case	001-2012C4	1
NP	4 amp fuse	Hardware	1
	Mounting Kit Assembly	030-2014MK (Includes All Parts)	

Installation Instructions

1. Identify 12V power source for wires to connect.
 - a. Eye loops included if wiring directly to the battery is desired.
 - b. Test for key power source if preferred to have power to the USB shut off with the key.
2. Once power source is identified, cut wires to desired length.
3. Crimp the two supplied quick connectors onto each the white and black wire.
4. Remove the round locking plastic nut from USB plug before connecting the wires. Black (+) White (-).
5. The wires will then be hooked to the designated terminals on the bottom of the USB plug
6. Drill a 1 1/8" hole in the preferred mounting location. Be sure to clean any sharp edges after drilling.
7. Feed the wires through the mounting hole.
8. If using the round plastic nut to secure plug in place, slide the nut back over the wiring before connecting the wires to powered source.
9. Connect the wires to the identified power source if easier to do so before tightening the plug into place.
10. Tighten plug using either the round plastic nut or mounting plate and two screws, both options supplied.
11. Once connected, hook a USB charging cord into the plug and connect a mobile device/tablet to ensure the plug is operating as you wish (key power working properly if necessary).

NOTE: This plug is not designed to charge two iPads. System damage could occur if this is attempted. System will charge a mobile phone and iPad simultaneously without problem.

Optional iPad Display Kit (030-4670DK)

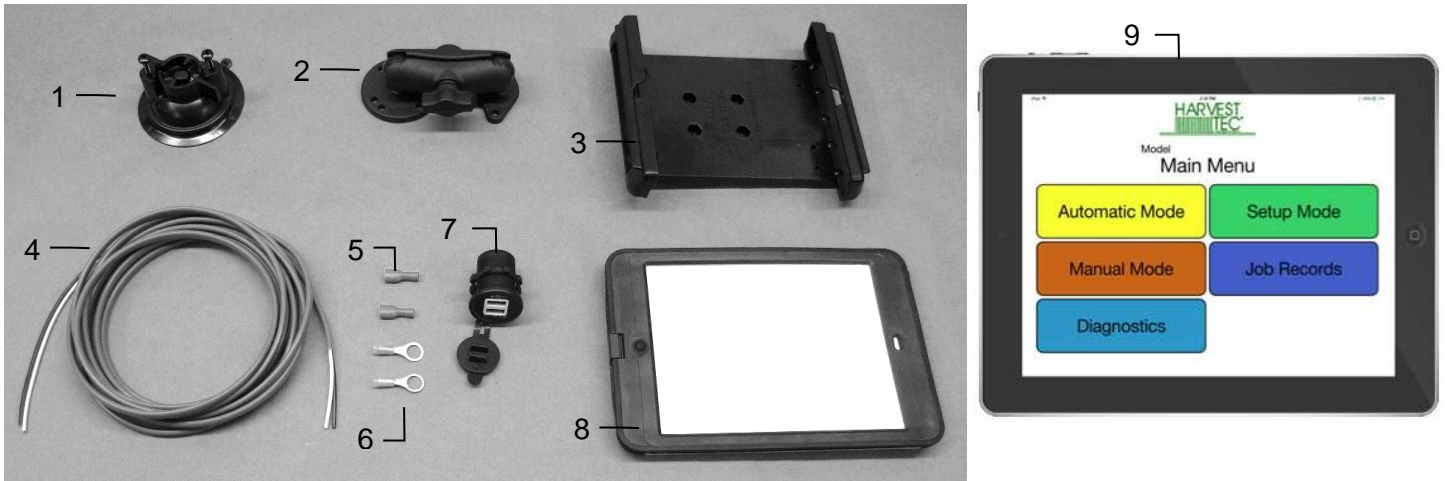

Ref	Description	Part #	Qty	Ref	Description	Part #	Qty
1	Suction cup mount	001-2012SCM	1	7	iPad Mini Charger 12V	001-2012P	1
2	Ram mount	001-2012H	1	8	iPad Mini 4 case	001-2012C4	1
3	iPad Mini spring load cradle (Mini 4)	001-2012SLC	1	9	iPad Mini 4	006-4670IP	1
4	16 gauge power wire	006-4723P	1	NP	4 amp fuse	Hardware	1
5	Female spade connector	Hardware	2				
6	Eye loop connector	Hardware	2				
					Mounting Kit Assembly	030-4670DK (Includes All Parts)	

Installation Instructions

1. Identify 12V power source for wires to connect.
 - a. Eye loops included if wiring directly to the battery is desired.
 - b. Test for key power source if preferred to have power to the USB shut off with the key.
2. Once power source is identified, cut wires to desired length.
3. Crimp the two supplied quick connectors onto the white and black wire.
4. Remove the round locking plastic nut from USB plug before connecting the wires. Black (+) White (-).
5. The wires will then be hooked to the designated terminals on the bottom of the USB plug
6. Drill a 1 1/8" hole in the preferred mounting location. Be sure to clean any sharp edges after drilling.
7. Feed the wires through the mounting hole.
8. If using the round plastic nut to secure plug in place, slide the nut back over the wiring before connecting the wires to powered source.
9. Connect the wires to the identified power source if easier to do so before tightening the plug into place.
10. Tighten plug using either the round plastic nut or mounting plate and two screws, both options supplied.
11. Once connected, hook a USB charging cord into the plug and connect a mobile device/tablet to ensure the plug is operating as you wish (key power working properly if necessary).

NOTE: This plug is not designed to charge two iPads. System damage could occur if this is attempted. System will charge a mobile phone and iPad simultaneously without problem.

Harvest Tec Inc. Warranty and Liability Agreement

Harvest Tec, Inc. will repair or replace components that are found to be defective within 12 months from the date of manufacture. Under no circumstances does this warranty cover any components which in the opinion of Harvest Tec, Inc. have been subjected to negligent use, misuse, alteration, accident, or if repairs have been made with parts other than those manufactured and obtainable from Harvest Tec, Inc.

Our obligation under this warranty is limited to repairing or replacing free of charge to the original purchaser any part that in our judgment shows evidence of defective or improper workmanship, provided the part is returned to Harvest Tec, Inc. within 30 days of the failure. If it is determined that a non-Harvest Tec branded hay preservative has been used inside the Harvest Tec applicator system where the failure occurred, then Harvest Tec reserves the right to deny the warranty request at their discretion. Parts must be returned through the selling dealer and distributor, transportation charges prepaid.

This warranty shall not be interpreted to render Harvest Tec, Inc. liable for injury or damages of any kind, direct, consequential, or contingent, to persons or property. Furthermore, this warranty does not extend to loss of crop, losses caused by delays or any expense prospective profits or for any other reason. Harvest Tec, Inc. shall not be liable for any recovery greater in amount than the cost or repair of defects in workmanship.

There are no warranties, either expressed or implied, of merchantability or fitness for particular purpose intended or fitness for any other reason.

This warranty cannot guarantee that existing conditions beyond the control of Harvest Tec, Inc. will not affect our ability to obtain materials or manufacture necessary replacement parts.

Harvest Tec, Inc. reserves the right to make design changes, improve design, or change specifications, at any time without any contingent obligation to purchasers of machines and parts previously sold.

Revised 4/17

HARVEST TEC, INC.
P.O. BOX 63
2821 HARVEY STREET
HUDSON, WI 54016
PHONE: 715-386-9100
1-800-635-7468
FAX: 715-381-1792
Email: info@harvesttec.com