

Operation Manual

Model 600

Moisture Sensor Kit for Large Square Balers



*Equipment and Products
for Quality Hay.™*

P.O. Box 63 • 2821 Harvey Street • Hudson, WI 54016
800-635-7468 • www.harvesttec.com

(intentionally blank)

Harvest Tec Model 600 Operations Table of Contents

	<u>Page</u>
Introduction	4
Safety	4
Safety Decals	4
Bluetooth Operation	5
Turn On / Off iPad	5
Downloading Harvest Tec app	5
Shutting down the Hay App	6
Bluetooth Receiver	6
Operating the Hay App	7-9
Device selection	7
Manual selection	8
Recommended preservative	8
Tab descriptions	9
Automatic Mode & Manual Mode	9
Setup mode, Job Records, Software Versions	9
Screen Menus	10-16
Automatic mode	10
Manual mode	10
Setup mode	11-13
Setup mode if RFV Equipped	14
Software Versions	14
Job Records	15-16
Setting Up System for Initial Use	17-18
Bale rate settings & Baler Sensors	17
RFV Setup	18
Operation instruction	19-24
Automatic mode	19
Manual mode	20
Job records	21
Download Job Records	22
Export Job Records (emailing records)	23
Export Job Records (saving to iPad)	24
Wiring diagram	25
Common Questions	26
Troubleshooting	27
Maintenance	27
iPad Troubleshooting	28
Pin Outs	29-30
Parts Breakdown	31-34
Star wheel moisture sensors	31
Controls & Harness	32
Optional iPad Mounting Kit	33
Optional iPad Display Kit	34
Warranty Statement	35

Introduction

Thank you for purchasing a Harvest Tec Model 600 Moisture Monitor System. This 600 Moisture Monitoring System has been designed to be operated through an Apple iPad (not included) using the Hay App. As well as the option to plug directly into most tractors that have an ISOBUS Monitor. The 600 Moisture Monitoring System offers these advantages by operating through an Apple iPad:

1. Large bright, clear, colorful display
2. More durable and can be read in bright sunlight
3. Wireless connection in cab
4. Can be used for multiple other uses than just the applicator display
5. Option to tie-into the tractor ISOBUS system

The 600 Moisture Monitor kit includes the following parts: Dual Channel Processor (DCP), Moisture Sensors, Harnesses and Miscellaneous Hardware. For your convenience a parts break down for the 600 Moisture Monitor System is included in the back of this manual. If you do have questions please bring this manual into the dealership. They can assist you in ordering the correct replacement parts.

Right and Left sides are determined by facing in the direction of forward travel.

****iPad Mini or iPad 3rd Generation (2012) or newer, running the current iOS operating system or one version previous required for iPad option***

If choosing to operate the unit though the ISOBUS monitor, part number 006-6670A will need to be ordered through your local equipment dealer.

Safety

Carefully read all the safety signs in this manual and on the applicator before use. Keep signs clean and visible. Replace missing or damaged safety signs. Replacement signs are available from your local authorized dealer. See your installation manual under the replacement parts section for the correct part numbers.

Keep your applicator in proper working condition. Unauthorized modifications to the applicator may impair the function and/or safety of the machine. Carefully read and understand all of the baler safety signs before installing or servicing the baler. Always use supplied safety equipment on the baler to service the applicator.

Safety Decals

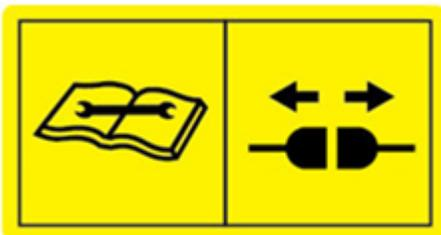

Number 1
Disconnect power before servicing.
Part no. DCL-8003



Number 2
Read and understand the operator's manual
before using or working around the equipment.
Part no. DCL-8000

Bluetooth Operation

Turn On / Off iPad using the Sleep/Wake button

*(Info from Apple User's Guide)

Turn iPad on. Hold down the Sleep/Wake button until Apple logo appears. iPad will take a moment to load.

You can lock iPad and put it to sleep when you're not using it. Locking iPad puts the display to sleep, saves the battery, and prevents anything from happening if you touch the screen.

Sleep/Wake Button



When you are not going to use the iPad for an extended period of time put the unit into sleep mode by pressing the Sleep/Wake button. Press Sleep/Wake button to wake iPad and then unlock iPad by entering passcode.

Turn iPad off. Hold down the Sleep/Wake button for a few seconds until the slider appears onscreen, then drag the slider to the right.

Downloading Harvest Tec App

1. If iPad does not have Wi-Fi turned on, select the Settings tab  then select the Wi-Fi tab (below).

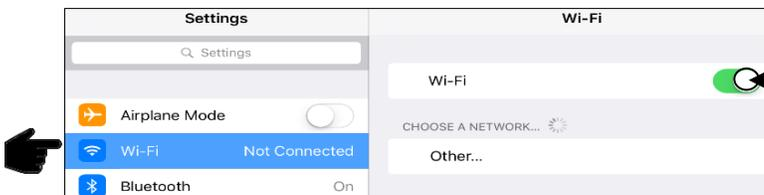

2. Turn Wi-Fi on by sliding button to the right.
*Green bar indicates ON

3. Use same process to turn on Bluetooth function

4. Select an available network when detected by the iPad, shown in area above that currently says 'Other.'

5. Select App Store icon (below) and open. *You will need a Wi-Fi connection available to view App Store.



****The Harvest Tec system WILL NOT appear under the Bluetooth tab in the Setting App. Open the Hay App to connect.**

Download the Hay App in the App Store by searching for 'Hay App' in the search bar in the top right corner of screen (right):

*The advertisements displayed on the App Store screen will change.

The app will have the icon as shown:



Hay App

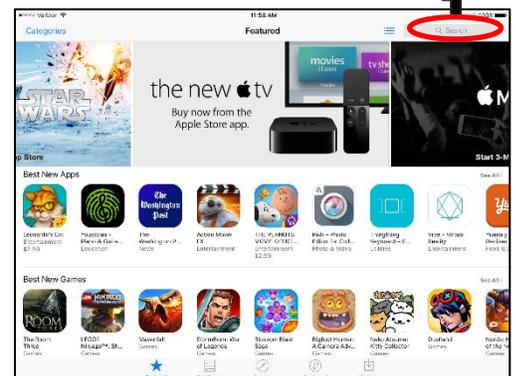

Note: Operation requires iPad Mini or iPad 3rd Generation (2012) or newer, running the current iOS operating system or one version previous required for iPad option.

Shutting Down the Hay App

To shut down the Hay App double click the home button (Figure A). This will show the open apps that are running on your iPad (Figure B).

*Note: By pressing the home button one time to return to the home screen, the Hay App **does not** shut down. The system will however, stop applying preservative after 10 seconds.



Figure A

Slide the app you want to shut down by sliding the app toward the top of the iPad, until the app is no longer visible (Figure C).

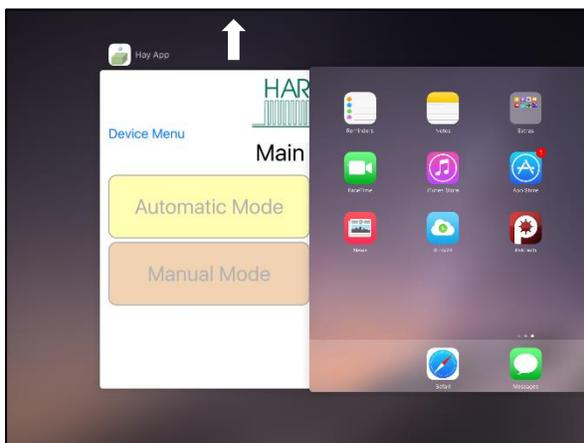

Figure B

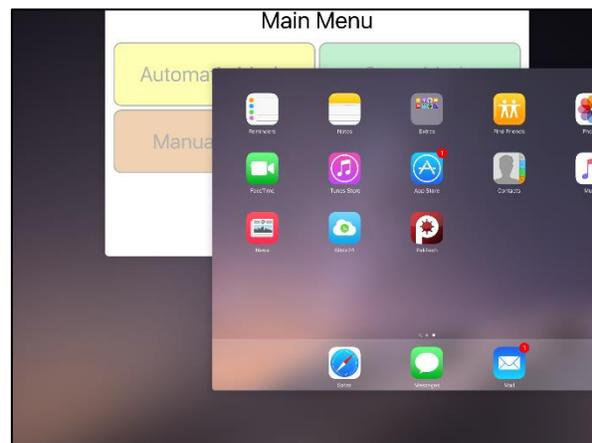

Figure C

Bluetooth Receiver

*New for production year 2018. All Bluetooth receivers (030-6672B) are now equipped with lights to indicated both power and iPad connection.

Blinking Lights – System is waiting for the processor to connect, which could take up to 35 seconds.

Red Light – The Bluetooth receiver has power

Green Light – When the proper active connection is selected in the Hay App menu, the green light will indicate connection with the iPad.



Operating the Harvest Tec iPad App (continued)

When ready to operate your applicator system, open the Hay App on the iPad by selecting the Hay App icon.

**Use the following information for Large Square Balers.*

Device Selection

The app will open to the Device Menu screen as shown below. Applicators which are equipped with the Bluetooth receiver that are within range (20') of the iPad and have power going to them, will be shown under the Active Connections section.

After the iPad connects to the Bluetooth receiver, select the applicator you want to connect with.

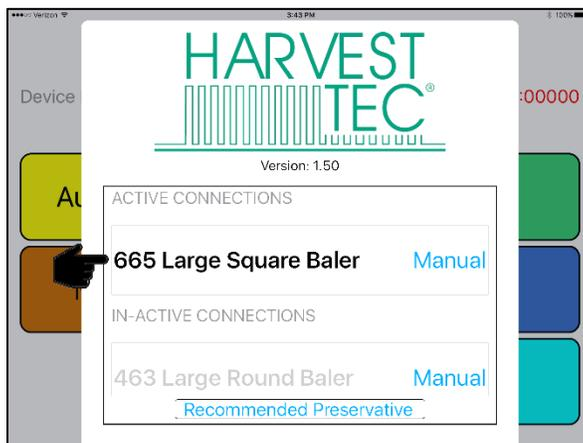

The In-Active Connections section will show applicator systems that have been connected in the past, but are not within range of the iPad or do not currently have power going to them (bottom left).

To remove a baler from the In-Active list, slide the bar displaying the baler name to the left, and select the Delete button that will appear (bottom right).

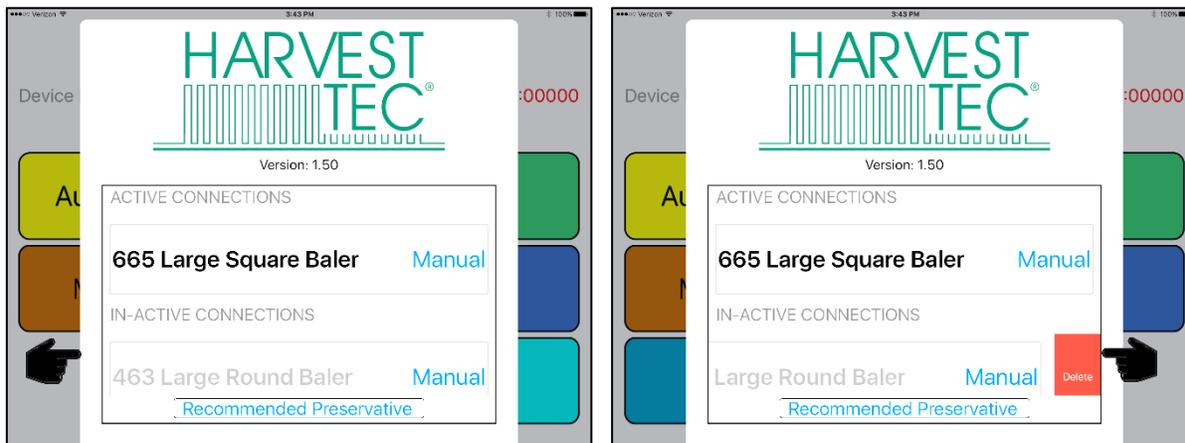

Operating the Harvest Tec iPad App (continued)

Manual Selection

Selecting the Manual button (below) displayed to the right of the baler name will open the operation manual for your baler.

*Use the following information for Large Square Balers.

*You do not need to be connected to a baler to open the manual after a baler has been connected.

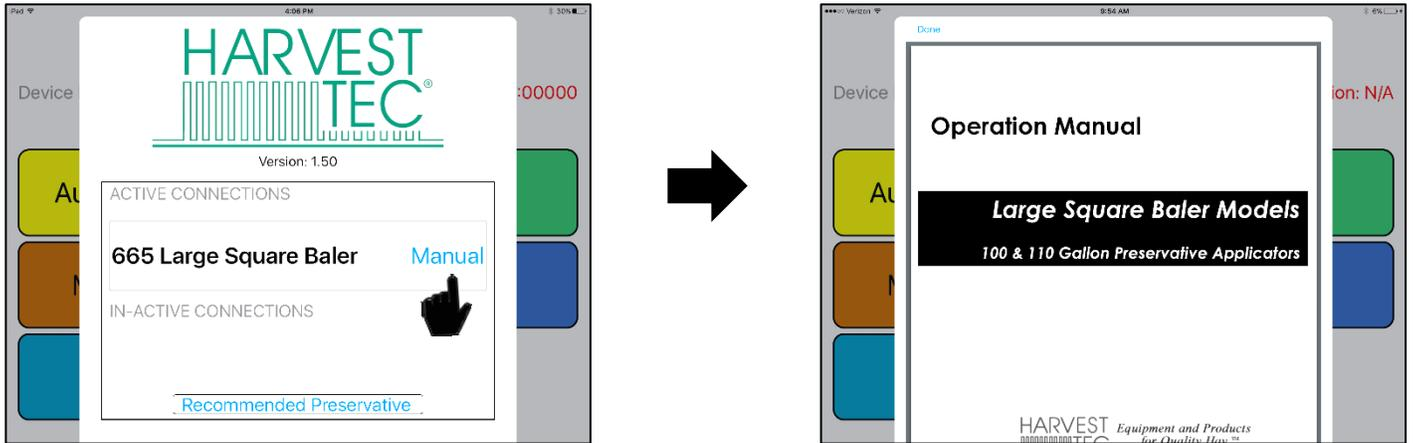

When finished reviewing the manual, press the Done button in the top left corner to return to the Device Menu.

Recommended Preservative

To view recommended preservative information, application rates, and frequently asked preservative questions, select Recommended Preservative (below).

*You do not need to be connected to a baler to open the recommended preservative page.

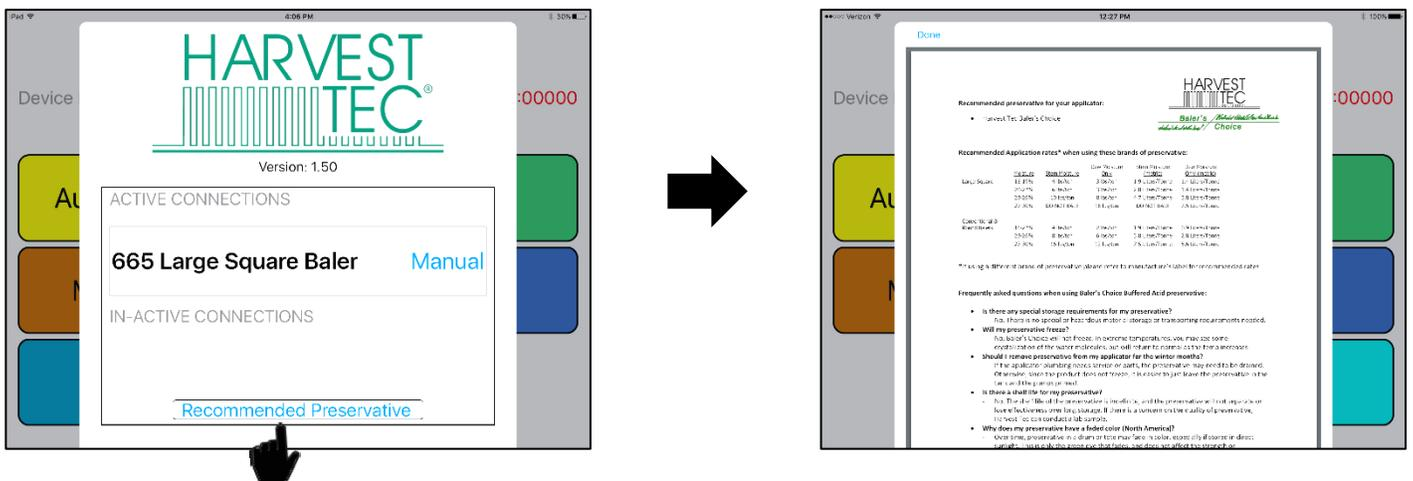

Operating the Harvest Tec iPad App (continued)

Once you have selected the baler you want to connect with from the Device Menu, the applicator main menu will display (below).

Ensure the iPad Bluetooth function is turned on in the Settings App.

*The applicator system will not appear under the Bluetooth Devices in the Settings App upon initial connection. You must open the Hay App to view the available devices by selecting the Device Menu. After you have connected through the Hay App, the system will then appear under the Bluetooth Devices in the Settings App.

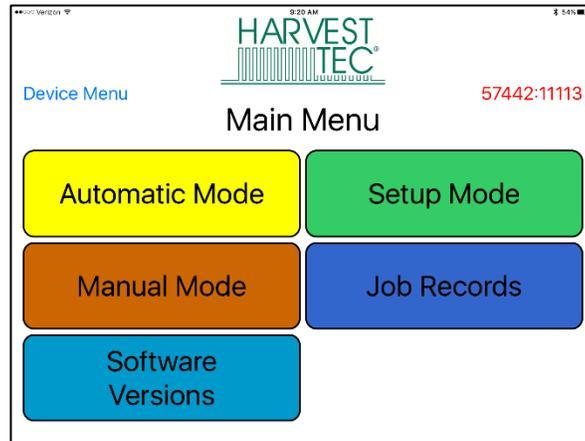

Tab Descriptions

Automatic Mode: This mode allows you to use all of the applicator features such as adjusting preservative application on the go and counting total pounds of product used.

Manual Mode: Allows operator to manually turn pumps on and off. This mode also has moisture content displayed. Use this mode to prime pumps.

Software Versions: Selecting this tab will display the software currently installed.

Setup Mode: This mode allows the operator to adjust bale rate, application rate settings and select tip output.

Job Records: Keep track of up to 300 jobs with total product used, average moisture content, tons baled, and baling date.

Screen Menus

Use the screen shots below to navigate through the operation screens.

Automatic Mode

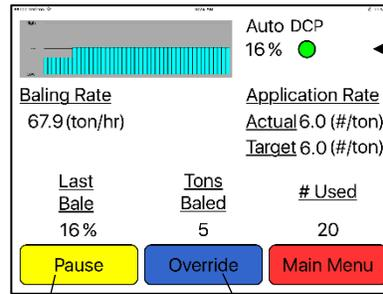
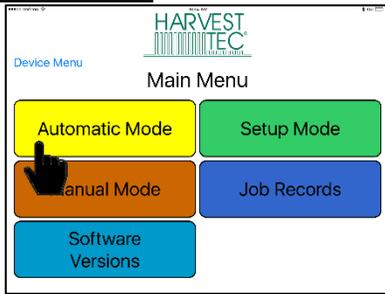

Bluetooth Connection Indicator
 Green -DCP is connected
 Yellow -DCP connecting
 Red -DCP not connected
 # Used will display 0 with moisture only systems

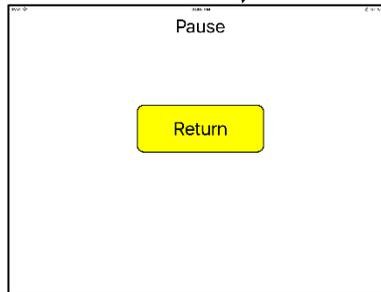

Manual Mode

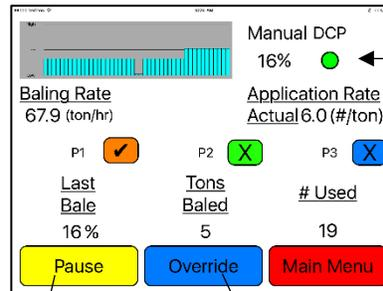
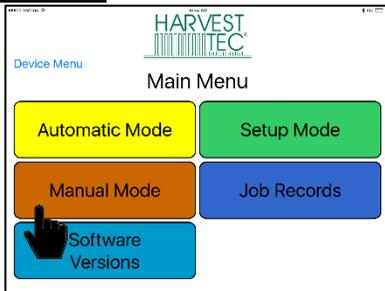

Bluetooth Connection Indicator
 Green -DCP is connected
 Yellow -DCP connecting
 Red -DCP not connected
 X -Pump is OFF
 ✓ -Pump is ON
 Ensure pumps are off for moisture only operation

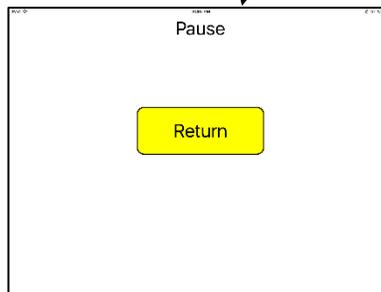

Operation Note:

Pressing the Home Button on the iPad **WILL NOT** immediately stop the system from reading moisture.

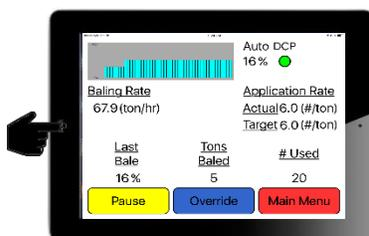

Select **Pause** or **Main Menu** to stop application

*To close app see the Shutting Down Hay App Section

**When the app is not displayed for 10 seconds, the moisture readings will stop.

Setup Mode – Large Square Balers

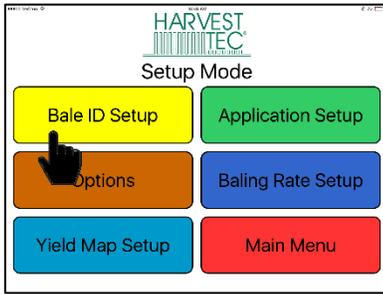
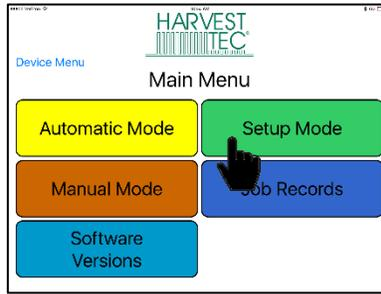

*Only used if equipped with Tagger

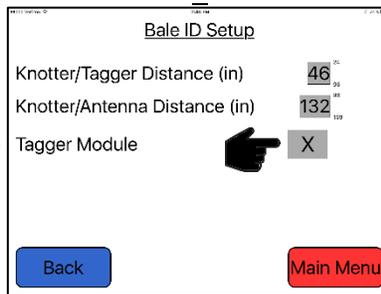

Turn Tagger ON by selecting the X

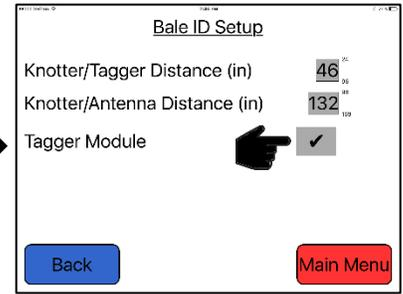

✓ Indicates tagger is ON

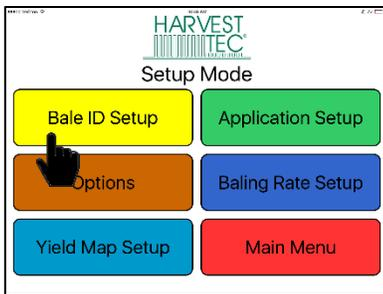

*If RFV Equipped, additional options will appear on Bale ID Screen (next)

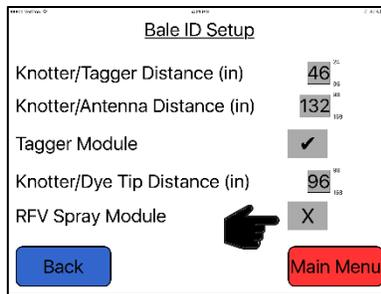

If using RFV Spray Module, turn ON by selecting the X

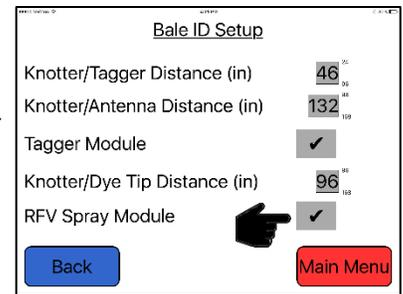

✓ Indicates Spray Module is ON

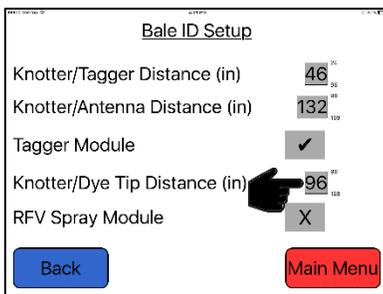

Make sure Knotter/Dye Tip Distance is correct

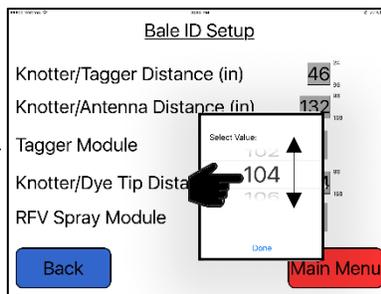

Select correct distance

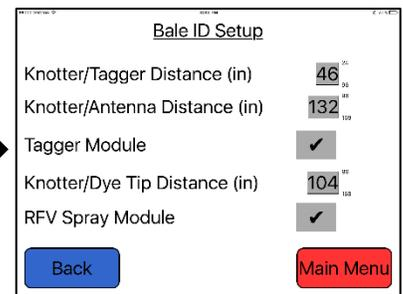

Setup Mode – Large Square Baler (continued)

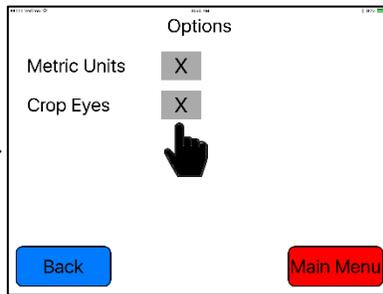
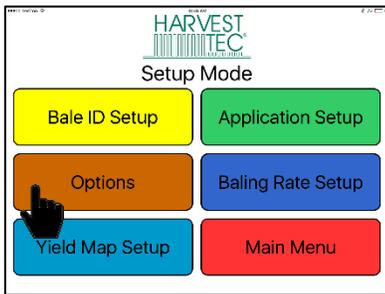

*Select X to turn on options shown

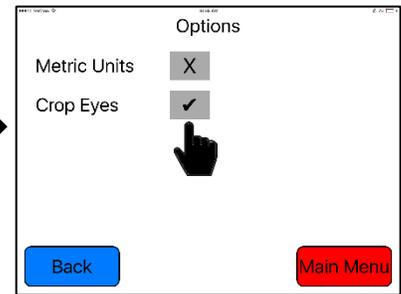

✓ Indicates Crop Eyes are ON

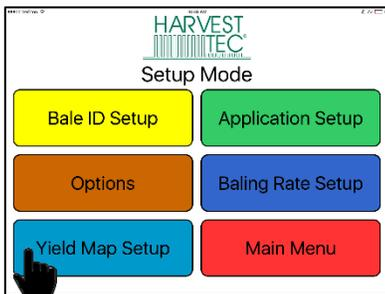

*Only used if equipped with GPS

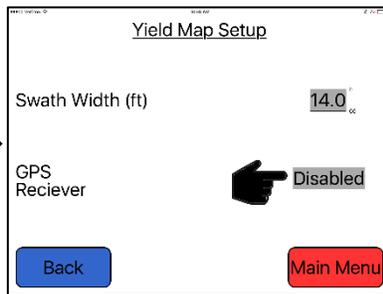

*Select grey area to change

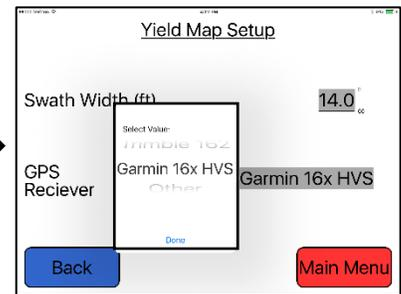

*Select appropriate GPS unit

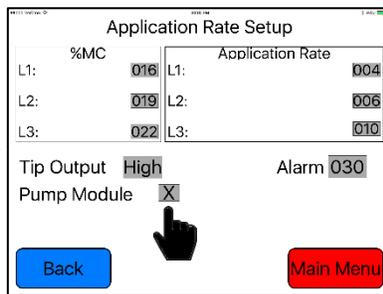
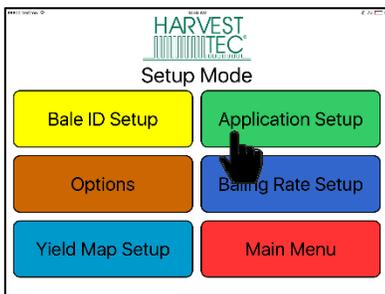

*Ensure pump module is shut off
X indicates module is off

Setup Mode – Large Square Baler (continued)

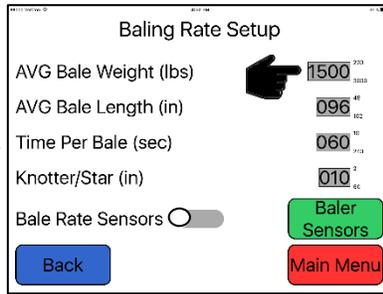
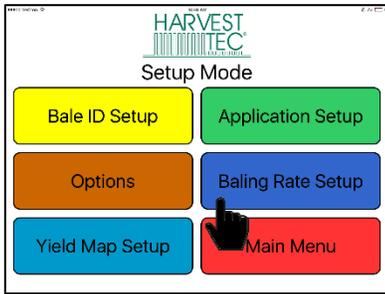

*Select correct bale weight, length, and time per bale information

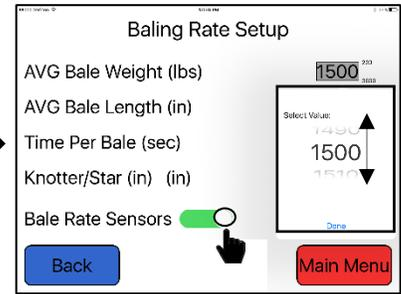

*Turn on Bale Rate sensor, Green bar indicates sensors are ON

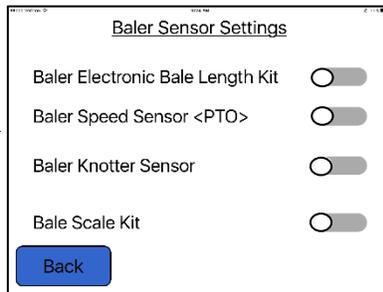
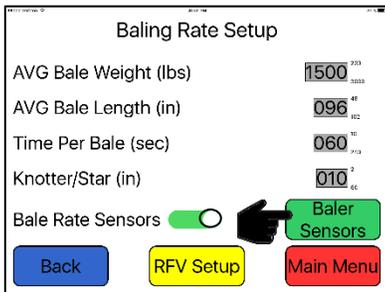

*Ensure all baler sensors are turned OFF

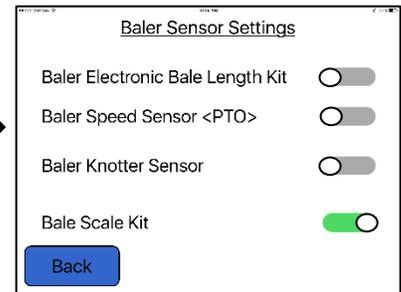

*If using a scale kit, turn sensor ON

Setup Mode – Large Square Baler (If RFV Equipped)

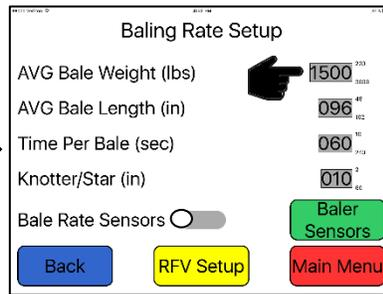
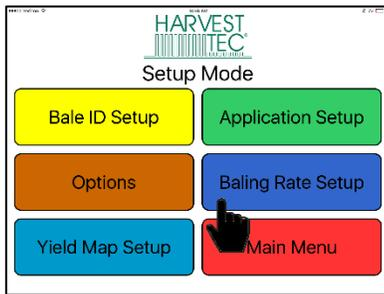

*Select correct bale weight, length, and time per bale information

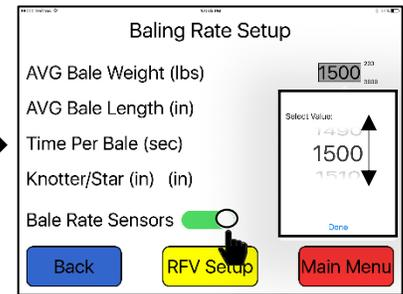

*Turn on Bale Rate sensor, Green bar indicates sensors are ON

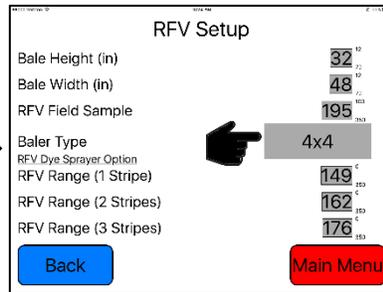
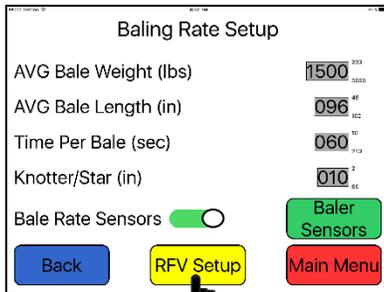

*Select correct bale size

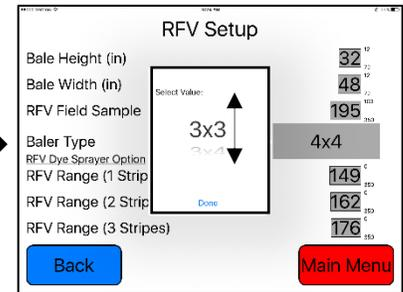

Software Versions

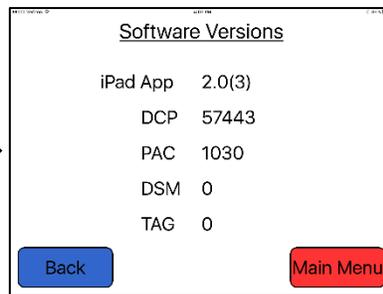
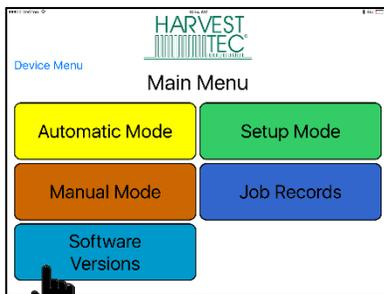

*Versions shown are examples (will not match your applicator)

Job Records

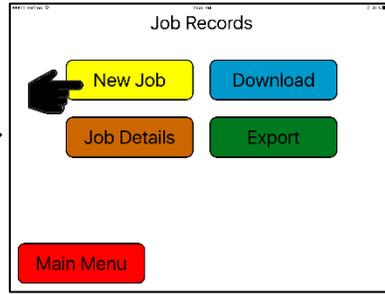
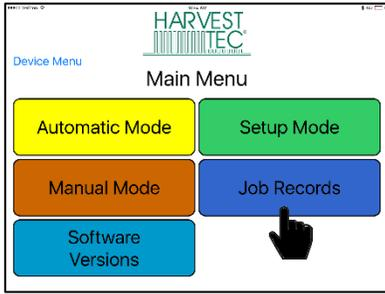

Type desired Field Name, select Create Job

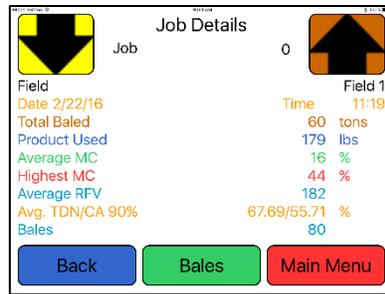
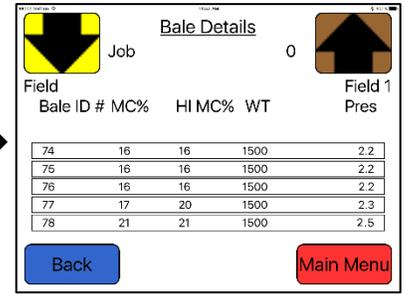
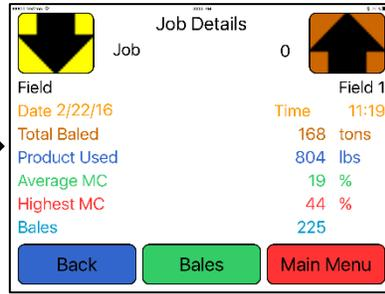
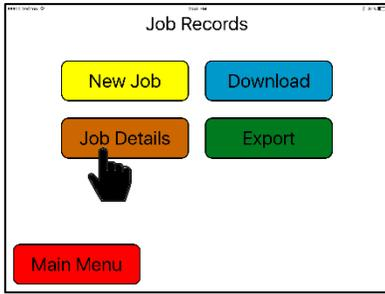

*When RFV Equipped, Average RFV, Ave TDN/CA90% info will be added

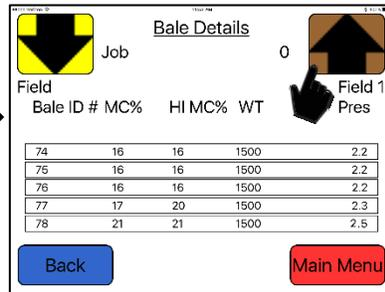
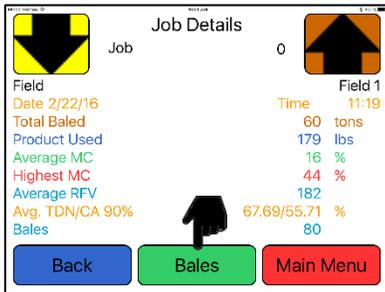

For Bale details select Bale Button

Use arrows to change jobs shown

Job Records (continued)

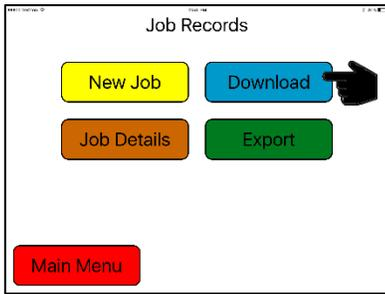

Select Download when wanting to download job records to USB Stick

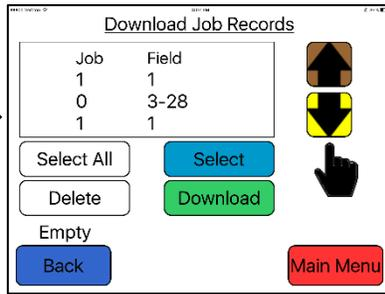

Use arrows to change jobs shown.
 ↕ Indicates selected jobs

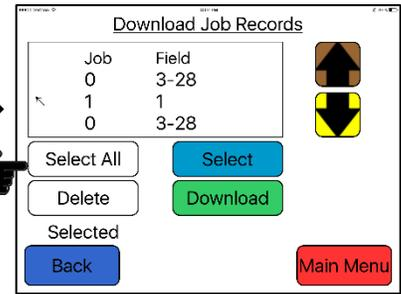

Pressing the Select or Select All tab to choose which job to download or delete

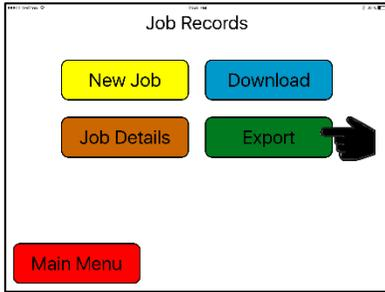

The Export allows you to send an email a file with selected job records



When the Export page is opened the bale information in each job will be retrieved.



When all bales have been retrieved, Export tab will activate, select a job(s) to export



If choosing one job to email, select the Mail tab. Multiple jobs can be selected

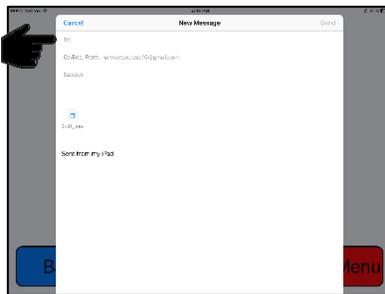

Email will appear w/file attached, enter address
 *If two or more jobs selected, email will appear

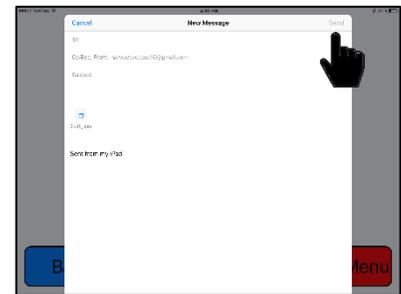

Press the Send button in top right corner, (your iPad notification sound will play)



If choosing to view job on iPad, recommended to download Excel app to view job records information

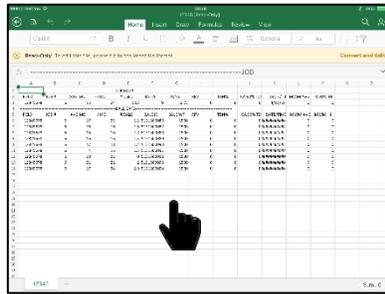

After Excel app is selected, the job record spreadsheet will open
 *iPad can only view 1 job at a time.

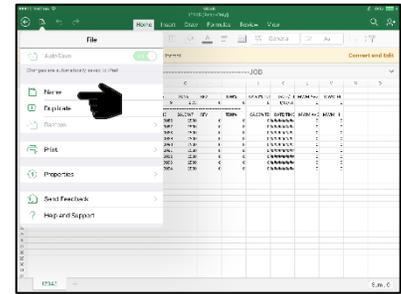

To save the job, select Name from the drop down tab

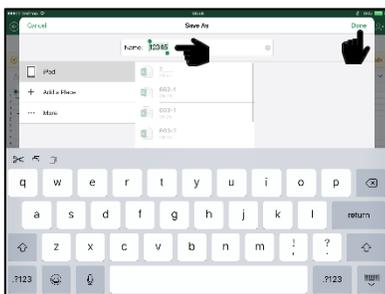

Enter desired name in center of page and press Save on the top right corner

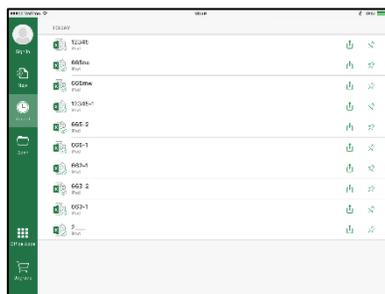

After selecting Save, the list of saved files in Excel will appear. Select any job to view

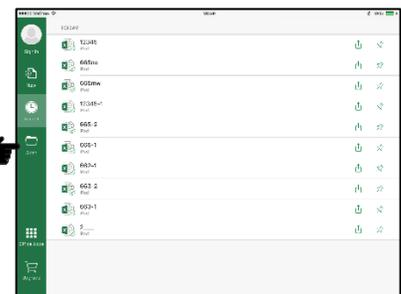

You also can view the jobs saved by selecting Open tab after opening the Excel app

Baling Rate Settings – Large Square Balers

After pushing the SETUP MODE key in the Main Menu screen, the screen on the left will appear:

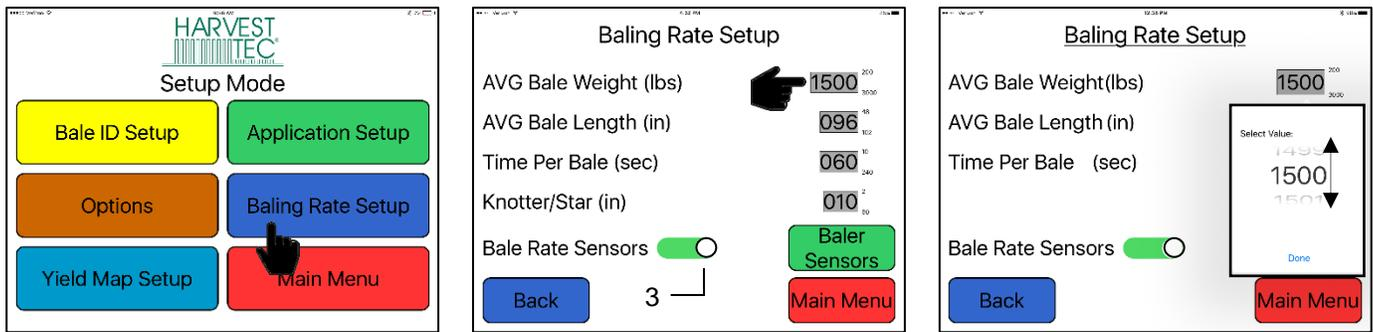

1. On the setup mode screen press the BALING RATE key.
2. Press the grey number value to the right of AVG Bale Weight (Lbs). To adjust the weight of your bales, the scroll tool shown on the right will display. Scroll through the values to select correct information, press DONE when value has been selected. The information will be saved until updated. Use the same procedure for adjusting bale length and time per bale.
3. Large square balers are equipped with Bale Rate Sensors which can be turned ON by sliding the bar to the right as shown above. A green bar indicates that the bale rate sensors are on. While a grey bar means the bale rate sensors are off.
Note: Bale rate sensors are used instead of a fixed time per bale to help determine a ton per hour reading.
4. Press the BACK key found on the bottom left hand figure of the screen to return to SETUP MODE screen or press the MAIN MENU key to return to the opening screen.

Baling Rate Settings – Baler Sensors

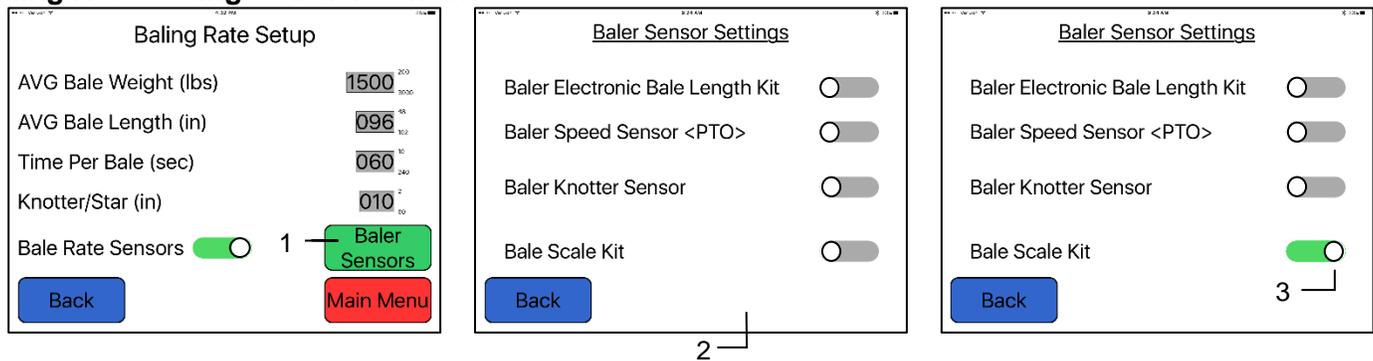

1. On the Baling Rate Setup screen select the Baler Sensors Tab.
2. Ensure all baler sensors are turned off on the Baler Sensor Settings Tab.
3. If using a Bale Scale Kit, turn on that sensor by sliding the tab to the right. A green bar indicates the sensor is turned on.

RFV Setup

Use the information below when your applicator is RFV Equipped. *Only available on large square balers.

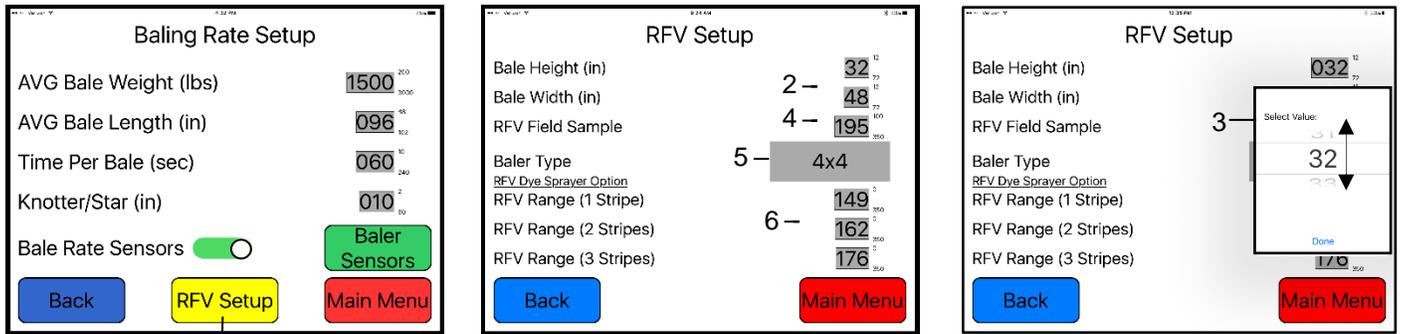

1. Select the RFV Setup tab on the Baling Rate Setup Screen.
2. Select the correct height and width of bale by selecting the grey area. All values can be changed.
3. After selecting a value to change, a menu will appear to scroll through and select the correct value and press done to save the information.
4. Select the RFV Field Sample value and input the correct value. *This is the RFV value that has been tested by a lab, which is needed to properly measure the RFV value when baling.
5. Choose the correct baler type: 3x4, 3x4, 4x4, or 3x4 Krone HDP
6. Select your desired RFV ranges from each tip to show either 1 stripe, 2 stripes, or 3 stripes. The preset values from the factory will be set at 150, 170, and 190.

***If you are baling hay with an RFV value below the selected 1 stripe value, the system will not spray the bale.**

Operation Instructions

Automatic mode will allow you to view the moisture information, bale rate, last bale moisture and tons baled.

Automatic Mode

After pushing the AUTOMATIC MODE key in the Main Menu screen, the following screen will appear:

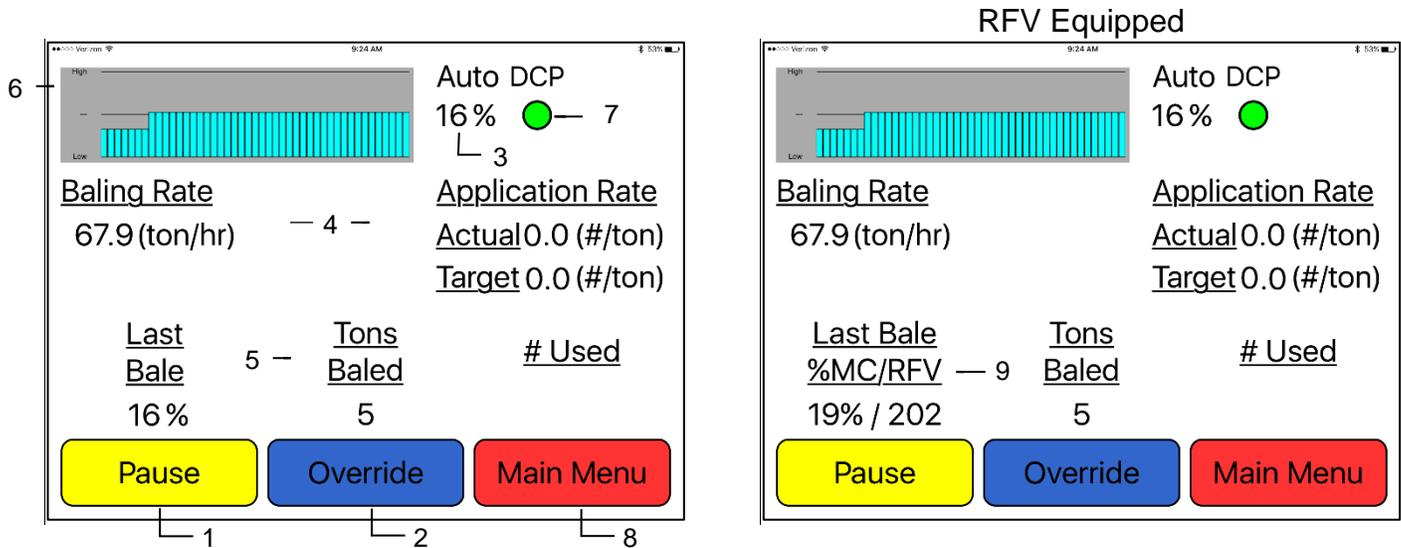

1. To pause the unit while in operation select the Pause key.
2. The Override button will turn on all three pumps at the same time for full output of the system. This button is not used with a moisture only system.
3. The moisture content is shown in the upper right hand corner.
4. Baling Rate and Application Rate are shown in the middle of the screen. Application rate will read zero with moisture only systems.
5. Volume of preservative used will be shown at the bottom of the screen will show accumulated pounds of preservative used on the go. There will not be any information shown in the # Used section with a moisture only unit.
6. The graph shows the moisture trend from the past 90 seconds in 3 second intervals.
7. The DCP button shown when using an iPad displays your connection signal with the Bluetooth receiver. Green – DCP is connected, Yellow – DCP is connecting, Red – DCP not connected.
8. Press the MAIN MENU key to return to the opening screen.
9. When your applicator is RFV Equipped, the RFV value will be displayed next to the Last Bale moisture reading in the bottom left corner of the screen.

Manual Mode

Manual mode can be used to view the moisture information, bale rate, last bale moisture and tons baled.

After pushing the MANUAL MODE key in the Main Menu screen, the following screen will appear:

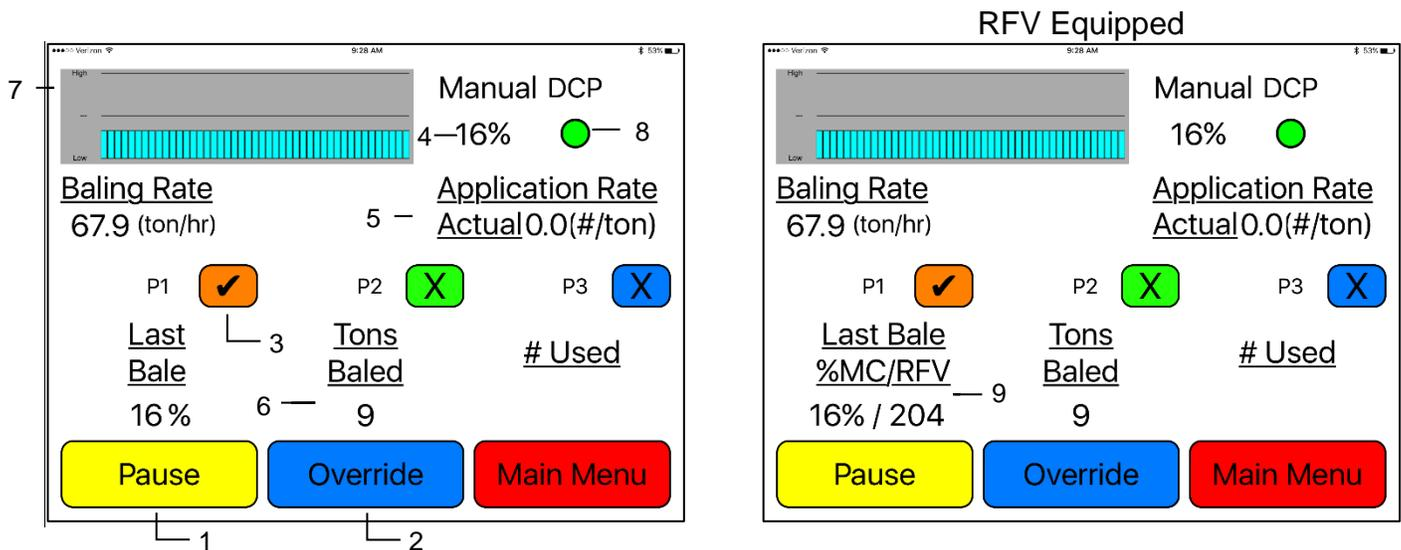

1. To pause the unit during operation select the Pause key.
2. The Override button will turn on all three pumps at the same time for full output of the system. This button is not used with a moisture only system.
3. If there is a checkmark displayed in the colored box next to P1, P2 or P3, change it to an 'X' by pressing the colored area. The 'X' indicates that the pump is turned off. If there is a checkmark shown, the system will give a PAC error with a moisture only unit, as there is no pumps with the system.
4. The moisture content is shown in the upper right hand corner.
5. Baling rate and Application rate are shown in the middle of the screen. The application rate will display zero with a moisture only unit.
6. Volume of preservative used will be shown at the bottom of the screen will show accumulated pounds of preservative used on the go. There will not be any information shown in the # Used section with a moisture only unit.
7. The graph in the upper left hand corner shows the moisture trend from the last 90 seconds of baling (one reading every 3 seconds).
8. The DCP button shown displays your connection signal with the Bluetooth receiver.
Green – DCP is connected, Yellow – DCP is connecting, Red – DCP not connected.
9. When your applicator is RFV Equipped, the RFV value will be displayed next to the Last Bale moisture reading in the bottom left corner of the screen.

Job Records

After pushing the JOB RECORDS key in the Main Menu screen, the following screen will appear:

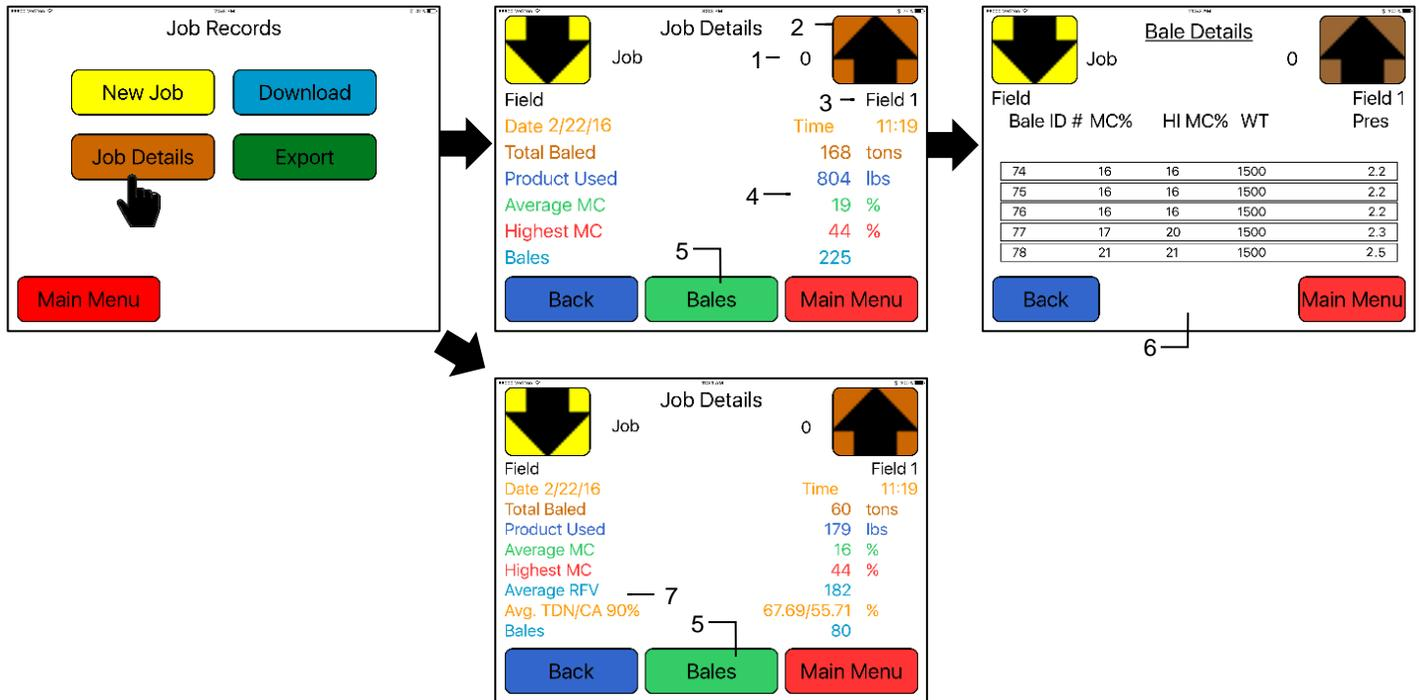

*When RFV Equipped, Average RFV, Ave TDN/CA90% info will be added

1. The job number will be displayed at the top center. The current job being viewed will always read "Job #: 0". Product used and average moisture content will be reset when the NEW JOB key is pressed. The job records screen will store up to 300 jobs allowing access previous jobs by using the up and down arrows.
2. Scrolling through previous jobs is done by pressing the UP or Down keys.
3. The field name is located under the up arrow.
4. The accumulated information from the field will be displayed in the middle of the screen. **Every time the NEW JOB key is pressed the accumulated pounds on auto and manual modes will be reset to zero.** After 300 jobs have been stored, the next time the NEW JOB key is pressed the system will start over with job one and the old job will be replaced.
5. Selecting the Bales button will open the Bale Details Screen.
6. The Bale Detail screen will display the individual bale information onto each line. Including Bale ID#, MC% (moisture percentage), HI MC% (high moisture percentage), WT (weight of bale) and Pres (preservative used per bale).
7. When your applicator system is RFV Equipped, the Average RFV and Avg. TDN/CA 90% calculations will be added to the job details screen.
8. To return the opening screen, press the MAIN MENU key.

NOTE: Initial start-up requires pressing the New Job key in the Job Records screen in order for Volume Used accumulation to be recorded. This only needs to be done once on initial start-up of system and not every time the system is started for operation.

Download Job Records

After pushing the JOB RECORDS key in the Main Menu screen, the following screen will appear:

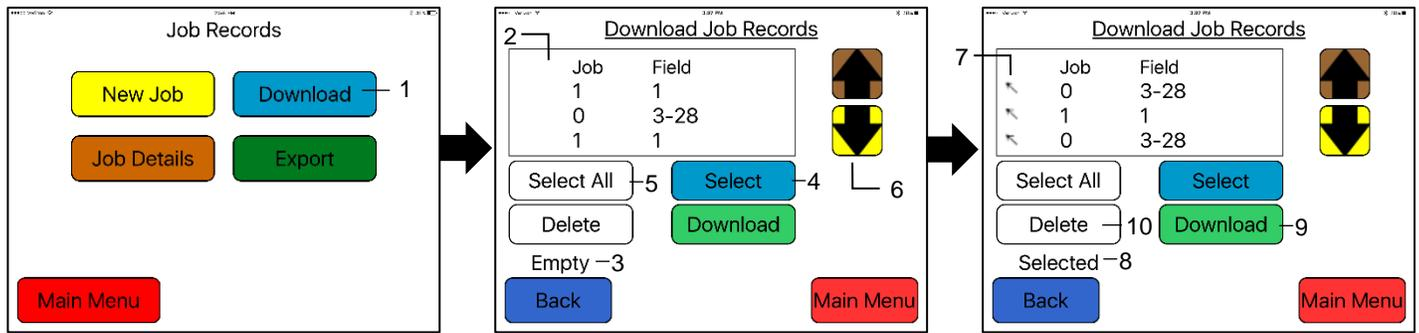

Prior to downloading job records a USB stick will need to be placed into the USB port on the applicator's Dual Channel Processor (DCP). Jobs will not be downloaded if the USB stick is plugged into the monitor.

1. To download the Job Records to a USB stick, select the Download button
2. The list of job records you have created, will display in the middle of the screen
3. When no jobs have been selected the status line will read Empty
4. To download individual job(s), tap the desired job(s) to be downloaded, or press the Select button
5. To select all of the jobs stored, press the Select All Button
6. Move through job records by selecting the up or down arrows
7. The  indicates selected jobs to be downloaded
8. When chosen jobs have been selected the status line will read Selected
9. Press Download button to download job records to USB Stick. The status line will read Downloading
10. Delete selected jobs by pressing the Delete button

Export Job Records (emailing records)

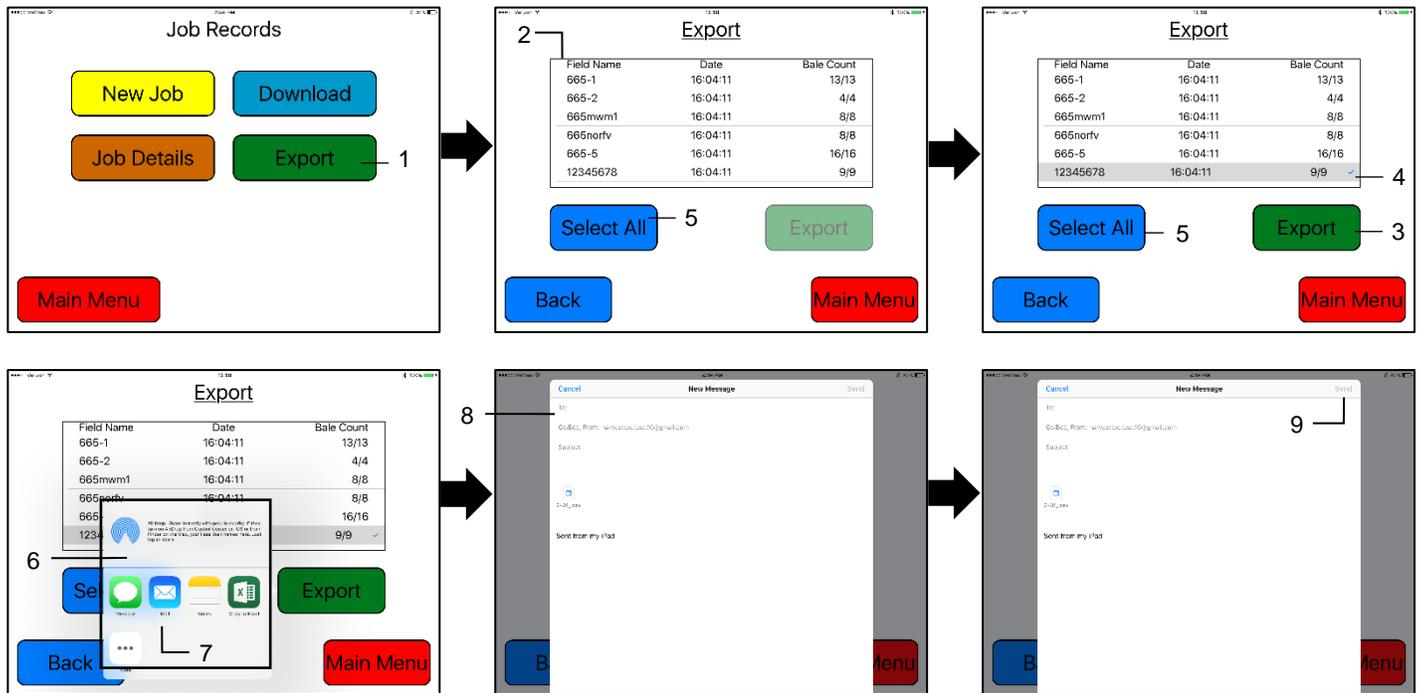

1. To export the Job Records through an email or save to the iPad select the Export button
2. The list of job records you have created, will display in the middle of the screen and the individual bale information will begin to download automatically. The number of bales will grow until equal to the number of bales available to export for each job record.
 - a. For example: When looking at a job record with 62 bales, the bale count will read 0/62 upon initially opening the page. The number will increase until it reads 62/62.
3. When all bales have been retrieved, the Export tab will become active
4. To export individual job(s), tap the desired job(s) to be exported. The ✓ indicated chosen job(s).
5. To select all of the jobs stored to be export, press the Select All Button
6. After selecting the Export tab, a small screen will appear with the mail app icon.
 - a. If selecting two or more jobs the email will automatically appear (skipping step 7)
7. Select the Mail app to open
8. Enter in the desired email address in the (To:) line of the email that will appear.
9. Press the send button to email the file to the email you have entered.

Export Job Records (saving to iPad)

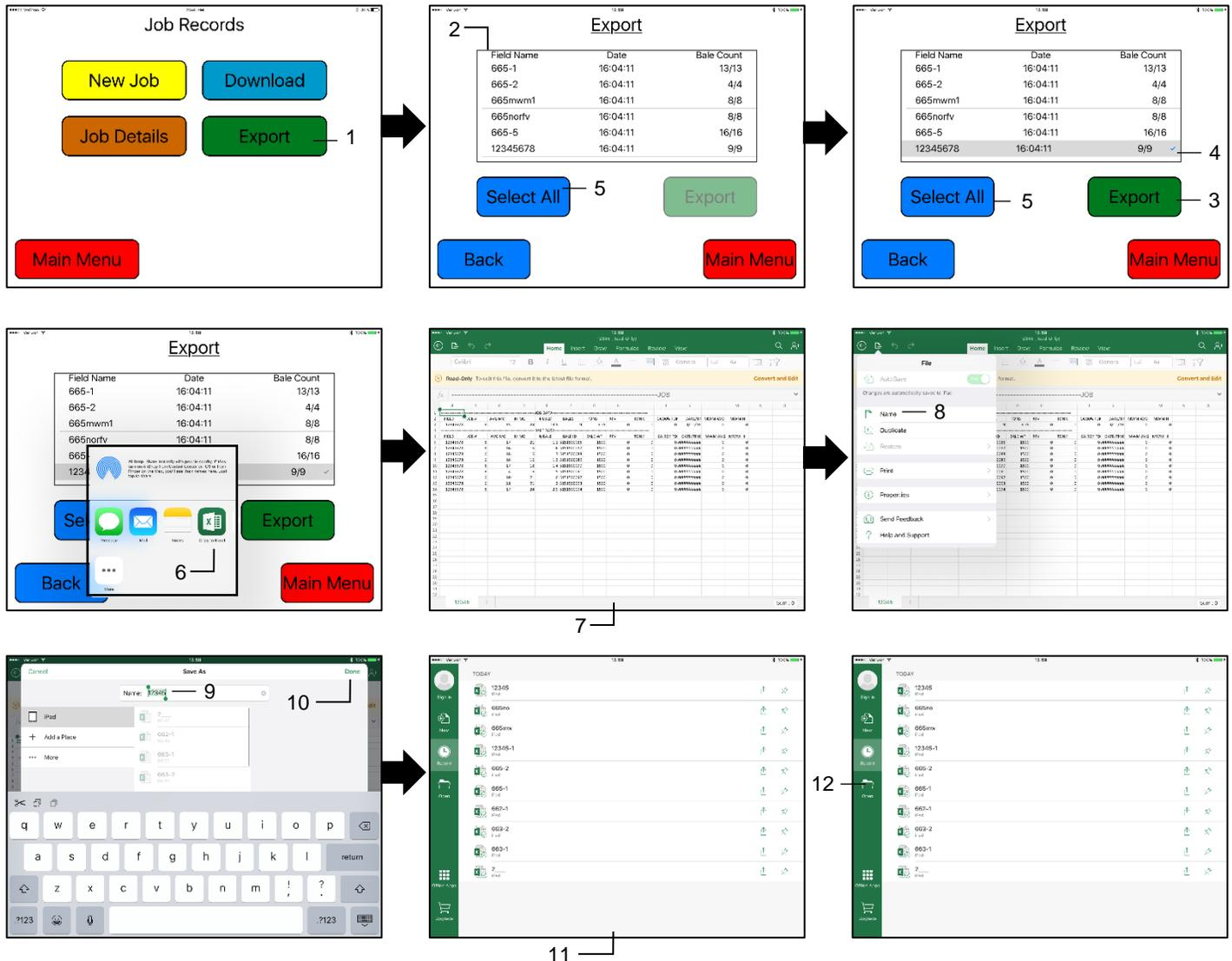

- To export the Job Records through an email or save to the iPad select the Export button
- The list of job records you have created, will display in the middle of the screen and the individual bale information will begin to download automatically. The number of bales will grow until equal to the number of bales available to export for each job record.
 - For example: When looking at a job record with 62 bales, the bale count will read 0/62 upon initially opening the page. The number will increase until it reads 62/62.
- When all bales have been retrieved, the Export tab will become active
- To export individual job(s), tap the desired job(s) to be exported. The ✓ indicated chosen job(s).
- To select all of the jobs stored to be export, press the Select All Button
- After selecting the Export tab, a small screen will appear with the Excel app icon.
 - It is recommended to download the Excel App to properly view the job records
 - Only one job can be selected at a time to view on iPad
- After the Excel app has been selected the job record spreadsheet will open
 - The iPad can only view one job at a time
- To save the job, select Name from the drop down tab
- Enter your desired file name
- Press the save button after entering your file name
- The list of saved files will appear
- You can also view the files by selecting the Open tab, when opening the Excel app

Wiring Diagram

- 1 Locate the tractor power/communication harness (006-6650TM).
- 2 At the back of the tractor run the power leads to the battery.
- 3 Connect the red power wire with the 50 amp fuse to the positive side (12 volt) of the battery.
 - a. **The power harness must be connected to the battery!** The unit will draw more amps than convenience outlets can handle. Any modifications of the power harness will void systems warranty. IF MODIFICATIONS ARE REQUIRED CONTACT HARVEST TEC FIRST!
 - b. **This unit will not function on positive ground tractors.**
 - c. **If the unit loses power while operating it will not keep track of accumulated pounds of product used and bale records.**
- 4 Connect the black ground wire to frame of tractor or negative side of (12 volt) battery.
- 5 Connect the Bluetooth Receiver (030-6672B) to the Communication Harness (006-6650TM). Place in a safe location in the cab. Behind the seat for example.
- 6 Connect the orange wires and attach the plug to the tractor's ISOBUS port.
- 7 If using the optional ISOBUS connector (006-6670A) connect the end to the Communication Harness (006-6650TM) in place of the Bluetooth Receiver shown below.
- 8 Connect the orange keyed power wires (006-5650K) to tractors Key Power source.

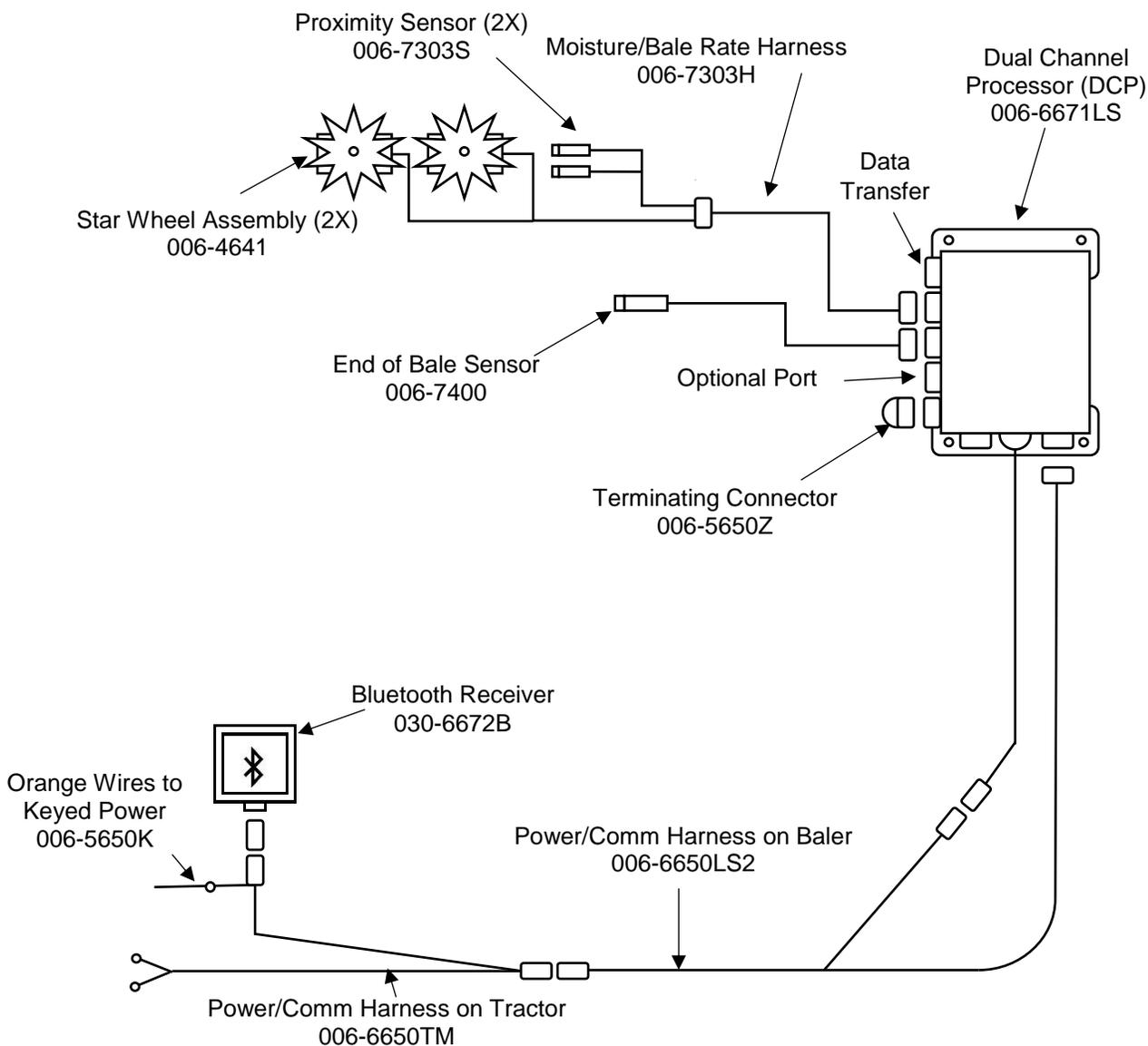

*Claas 3200-3400 balers will have star wheel assembly 030-4642 for mounting on side of bale chamber

Common Questions

1. How do I turn the system on/off?

To turn the system ON open the Hay App, then select the active system for the baler you are using. Press the Wake Up tab if the system was put into Standby mode when last used. If not in Standby mode, select Automatic or Manual mode to begin.

To turn the system OFF click the Standby tab on the Main Menu screen. To close the app double click the home button on the iPad and swipe the app that you would like closed, toward the top of the screen until it is no longer visible. See SHUTTING DOWN THE HAY APP for more details.

2. How to get in the LBS/TON, MC%, and TONS/HR screens?

In the Main Menu press the SETUP MODE key. From this screen you can change your application rates and how much product is applied. See SETTING UP FOR INITIAL USE for a detailed explanation of this process.

3. How does OVERRIDE work?

Override turns on all three pumps at full output. The pumps will remain at full output until the operator turns these pumps off by pressing the OVERRIDE key again.

4. The moisture content displays “LO” or “HI” all the time.

When the moisture content display does not change frequently while baling, there is likely a faulty star wheel connection. Initially check inside the white star wheel block, to see if the electronic swivel is in the star wheel shaft and that the star wheel shaft is not coming out of the block. Also, check all star wheel wires and connectors to see if there is a continuity of grounding problem.

5. Should the battery connections be removed before jump starting or charging a battery?

Yes. Anytime the tractor will have voltage going up rapidly the connections should be removed.

6. What is the expected battery life of the iPad when baling?

3.5 hours is the expected amount of time the battery when continuously baling. Shut off all other applications, wireless internet, and Wi-Fi signal to reduce the amount of programs iPad is running.

*It is recommended to use an accessory outlet charger when operating (not included with iPad).

7. What is the max distance for connection between the iPad and the Bluetooth Receiver?

The range for the connection will depend on the amount of equipment (tractor, baler, ect.) between the two devices. The max distance will range between 10' – 20'.

8. What do the lights on the 030-6672B indicate?

Blinking Lights – System is waiting for the processor to connect, which could take up to 35 seconds.

Red Light – The Bluetooth receiver has power. *Green Light* – When the proper active connection is selected in the Hay App menu, the green light will indicate connection with the iPad.

9. Can the Harvest Tec 600 be updated for preservative or a tagger?

Yes. Consult your local dealer for part numbers and pricing.

Add Preservative Application: Call Harvest Tec

Add Dye Spray Marker: 030-0840

Add Tagger: 030-0850

Add RFV: 800RFV

Troubleshooting

PROBLEM	POSSIBLE CAUSE	SOLUTION
Moisture reading errors (high or low)	1. Wire disconnected or bad connection between star wheels and DCP	1. Reconnect wire.
	2. Low power supply to DCP	2. Check voltage at box. (Min of 12 volts required.) See Diagnostics section of manual.
	3. Dry hay lower than 8% moisture or wet hay over 75%.	3. System reads 8-70% moisture.
	4. Ground contact with one or both star wheels and baler mounted processor.	4. Reconnect.
	5. Short in wire between star wheels & DCP.	5. Replace wire.
	6. Check hay with hand tester to verify.	6. Contact Harvest Tec if continued
Moisture readings erratic.	1. Test bales with hand tester to verify that DCP has more variation than hand tester.	
	2. Check all wiring connections for corrosion or poor contact.	2. Apply dielectric grease to all connections.
	3. Check power supply at tractor. Voltage should be constant between 12V & 14V	3. Install voltage surge protection on tractors alternator.
Terminal reads under or over power.	1. Verify with multi-meter actual voltage. Voltage range should be between 12-14 volts.	1. Clean connections and make sure applicator is hooked to battery. See Diagnostics section of manual.
Bale rate displays zero.	1. Bale rate sensors are reversed. 2. Short in cable. 3. Damaged sensor. 4. Sensor too far from star wheel.	1. Replace cable & sensor 2. Adjust gap between prox sensor and star wheel so it is 1/8-1/4" away.
Bluetooth Receiver lights will not illuminate	1. Bluetooth receiver not connected 2. Harness disconnected or Low power	1. Check connections and voltage. Minimum 12.5V needed.
	Blinking Lights – System is waiting for the processor to connect, which could take up to 35 seconds. <i>Red Light</i> – The Bluetooth receiver has power <i>Green Light</i> – When the proper active connection is selected in the Hay App menu, the green light will indicate connection with the iPad.	

Maintenance

Dielectric Grease Connections: Disconnect all harnesses on the applicator, clean the connections, and repack with dielectric grease.

Battery Connections: Follow the batteries safety warnings and clean the battery connections. If the connections cannot be cleaned, replace harness.

Winter Storage

Disconnect power from the Dual channel Processor (DCP).

Status Alerts

Two Status Alerts will appear on the Auto and Manual mode screens when the Job Records are approaching, or full of records.

Status Alert “**Bale Records: Less than 1K remaining**”. The system is now approaching the maximum amount of records that can be saved. When this code appears, download and delete jobs in the Job Records menu. Follow the instructions in Job Records to accomplish this.

Status Alert “**Bale Records failed – Memory Full**”. The system will no longer accept any new data until jobs in the Job Records menu are downloaded and deleted. Follow the instructions in Job Records to accomplish this.

iPad Troubleshooting

iPad Symptom	Troubleshooting
iPad won't turn on	- Turn your iPad off and on. Press and hold the Sleep/Wake button for a few seconds until a red slider appears; then slide it. Press and hold the Sleep/Wake button to turn on again.
	-Reset your iPad. Press the "Sleep/Wake" button and the "Home" button simultaneously for at least 10 seconds until the Apple logo appears on the screen. This reset will not damage your files.
	You may have a drained battery. Plug your iPad into your computer or AC adapter and see if anything happens. Ideally your iPad will recognize it has been connected to a power source and charge its battery. If it will no longer charge, the battery must be swapped with a replacement battery. Battery level is display in top right corner of iPad.
iPad won't connect to Bluetooth accessory	-Make sure that your Bluetooth accessory and iOS device are close to each other when connecting.
	-Make sure that your Bluetooth accessory is on and fully charged or connected to power. If it uses batteries, test them to see if they need to be replaced.
	-Restart your Bluetooth receiver, by removing power and reconnecting after 30 seconds.
	-Make sure that you have at least a 3 rd generation iPad with iOS8 or greater operating system on your iPad
	-On your iPad, go to Settings > Bluetooth and make sure that Bluetooth is on. If you can't turn Bluetooth on or you see a spinning gear, restart your iPad
	-Unpair the Bluetooth accessory, put the accessory back in discovery mode, then pair and connect it again. By tapping on its name in the Bluetooth accessories tab and then Forget this Device. In settings, tap on a device's name, then Unpair.
iPad touchscreen is slow or does not respond	-It may be that your screen is dirty. Try cleaning your screen. To do this, unplug everything, turn off iPad then with a very soft, lint-free and slightly damp cloth gently wipe the screen. Do NOT use window cleaners and paper towels.
	-If you have any screen protector sheet, try removing it.
iPad is not charging or is slow to charge	-In order to charge your iPad you can try either connecting your iPad to a power outlet or connecting to a USB 2.0 port on a computer. However, note that computers generally don't supply enough power to their USB ports to be able to charge an iPad. When this happens, a "Not Charging" message will appear.
How can I unlock my iPad if I forgot the passcode	If you cannot remember the passcode, you will need to <i>restore your device using the computer with which you last synced it</i> . This allows you to reset your passcode and resync the data from the device (or restore from a backup). If you restore on a different computer that was never synced with the device, you will be able to unlock the device for use and remove the passcode, but your <i>data will not be present</i> .
How do I send in my iPad for service?	Refer to your iPad owner's manual or contact apple customer service. DO NOT SEND iPad TO HARVEST TEC.
For other issues refer to your iPad Owner's Manual or contact Apple Directly	

***Harvest Tec Does Not Service iPads ***

Pin Outs

Power/Comm Harness 006-6650TM at Hitch

Pin 1	Red	+12V Power to TSD
Pin 2	Red	+12V Power to DCP
Pin 3	Orange	Keyed Power
Pin 4	Gray	Shield
Pin 5	Green	HT Can Low
Pin 6	Yellow	HT Can Hi
Pin 7	Orange	Can1 Hi
Pin 8	Black	Ground from TSD
Pin 9	Black	Ground from DCP
Pin 10	Blue	Can1 Low

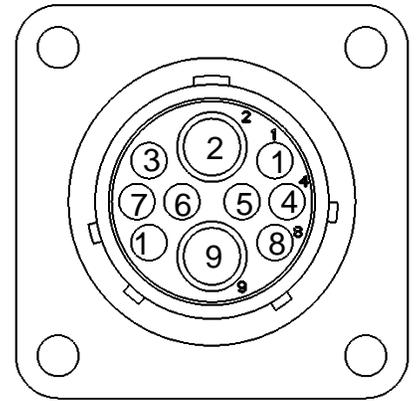

Power/Comm Harness 006-6650LSM2 at Hitch

Pin 1	Red	+12V Power to TSD
Pin 2	Red	+12V Power to DCP
Pin 3	Orange	Keyed Power
Pin 4	Gray	Shield
Pin 5	Green	HT Can Low
Pin 6	Yellow	HT Can Hi
Pin 7	Orange	Can1 Hi
Pin 8	Black	Ground from TSD
Pin 9	Black	Ground from DCP
Pin 10	Blue	Can1 Low

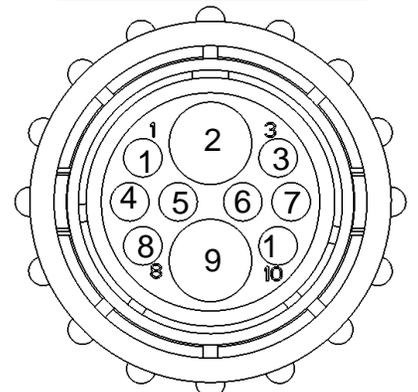

Bluetooth Receiver on Harness 006-6650TM

Pin 1	Red	+12V Power from DCP
Pin 2	Black	Ground from TSD
Pin 3	Yellow	HT Can Low
Pin 4	Gray	Shield
Pin 5	Green	HT Can Hi
Pin 6	Orange	Can1 Hi
Pin 7	Blue	Can1 Low

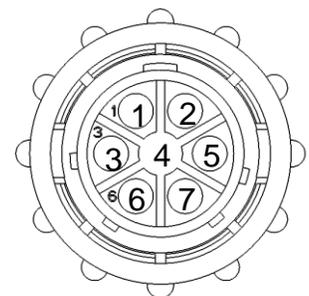

ISOBUS Plug Baler Side

Pin 1	N/A	
Pin 2	N/A	
Pin 3	120 OHM with Pin 5	
Pin 4	N/A	
Pin 5	120 OHM with Pin 3	
Pin 6	Orange	Can1 Hi
Pin 7	Blue	Can1 Low

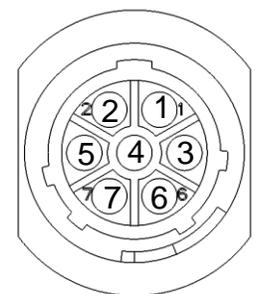

ISOBUS Plug Tractor Side

Pin 1	N/A	
Pin 2	N/A	
Pin 3	+12V Keyed Tractor Power	
Pin 4	N/A	
Pin 5	N/A	
Pin 6	N/A	
Pin 7	N/A	
Pin 8	Orange	Can1 Hi
Pin 9	Blue	Can1 Low

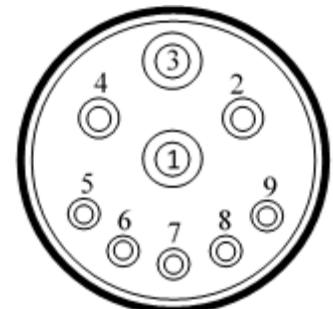

Pin Outs (continued)

Main Power Connector on DCP

Pin 1	Red	+12V Power from tractor
Pin 2	Black	Ground from tractor
Pin 3	Orange	Keyed power

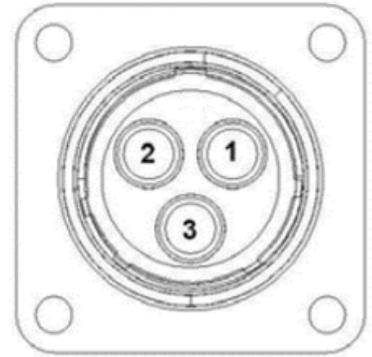

Star Wheel and Bale Rate Sensor connector on DCP

Pin 1	Blue	+12V Power
Pin 2	Orange	Ground
Pin 3	Black	Signal for sensor 1
Pin 4	White	Signal for sensor 2
Pin 5	N/A	
Pin 6	N/A	
Pin 7	N/A	
Pin 8	Violet	Star wheel input 1
Pin 9	Brown	Star wheel input 2



End of Bale sensor on DCP

Pin 1	Brown	Sensor Power
Pin 2	Blue	Sensor Ground
Pin 3	N/A	
Pin 4	Black	Signal from Sensor

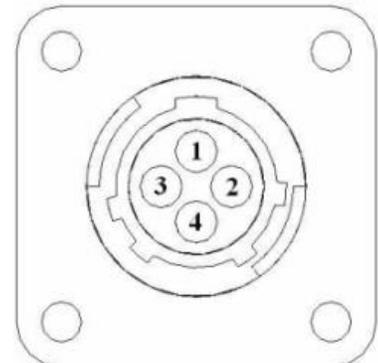

Parts Breakdown for Star Wheel Moisture Sensors

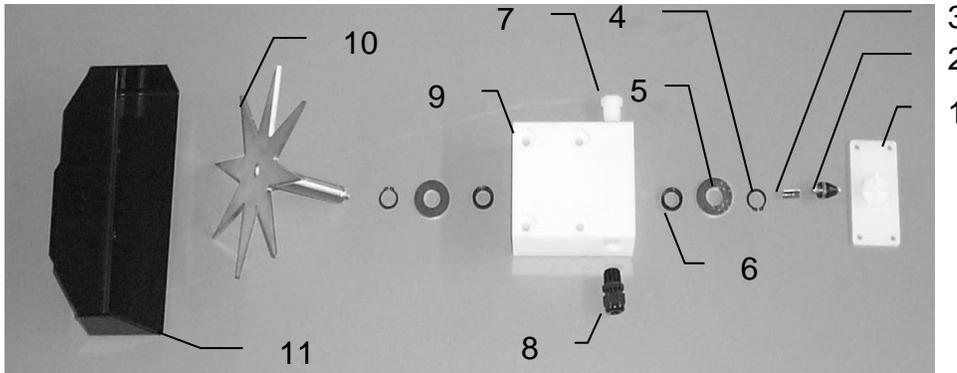

<u>Ref</u>	<u>Description</u>	<u>Part#</u>	<u>Qty</u>	<u>Ref</u>	<u>Description</u>	<u>Part#</u>	<u>Qty</u>
1.	Block cover	006-4641B	2	9.	Star wheel block	006-4641A	2
2.	Electronic swivel	006-4642A	2	10.	Star wheel sensor	030-4641C	2
3.	Swivel insert	w/ Ref # 10	2	11.	Twine guard-left	001-4645	1
4.	Snap ring (per side)	006-4641K	2		Twine guard-right (prox)	001-4644	1
5.	Washer (per side)	w/006-4641K	2				1
6.	Dust seal (per side)	w/006-4641K	2				1
7.	Plug fitting	003-F38	2	1-10	Star wheel assembly	030-4641	2
8.	Wiring grommet	008-0821A	2				

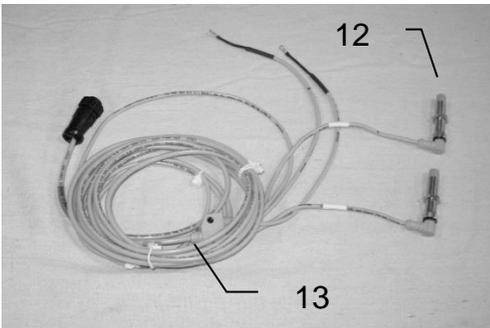

<u>Ref</u>	<u>Description</u>	<u>Part#</u>	<u>Qty</u>
12	Bale rate sensor	006-7303S	2
13	Moisture and bale rate harness	006-7303H	1

Vicon, Kuhn Balers

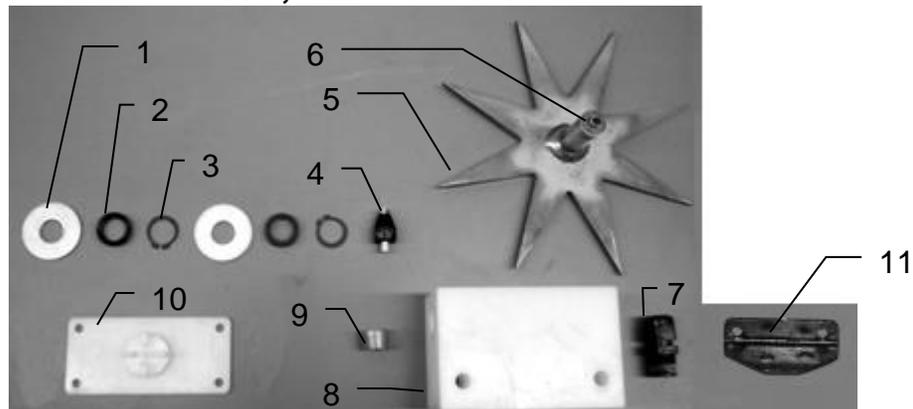

<u>Ref</u>	<u>Description</u>	<u>Part #</u>	<u>Qty</u>	<u>Ref</u>	<u>Description</u>	<u>Part #</u>	<u>Qty</u>
1	Washer (per side)	006-4642K	2	7	Wiring grommet	008-0821A	2
2	Dust Seal (per side)	w/006-4642K	1	8	Star wheel block	006-4641D	2
3	Snap Ring (per side)	w/006-4642K	2	9	Plug Fitting	003-F38	2
4	Swivel	006-4642A	2	10	Block Cover	006-4641B	2
5	Star Wheel	030-4641E	2	1-10	Star wheel assembly	030-4642	2
6	Insert	w/ Ref # 5	2	11	Prox Sensor Holder	001-4644SS	1

Parts Breakdown for 600 Series Control and Harnesses

Dual Channel Processor (DCP)

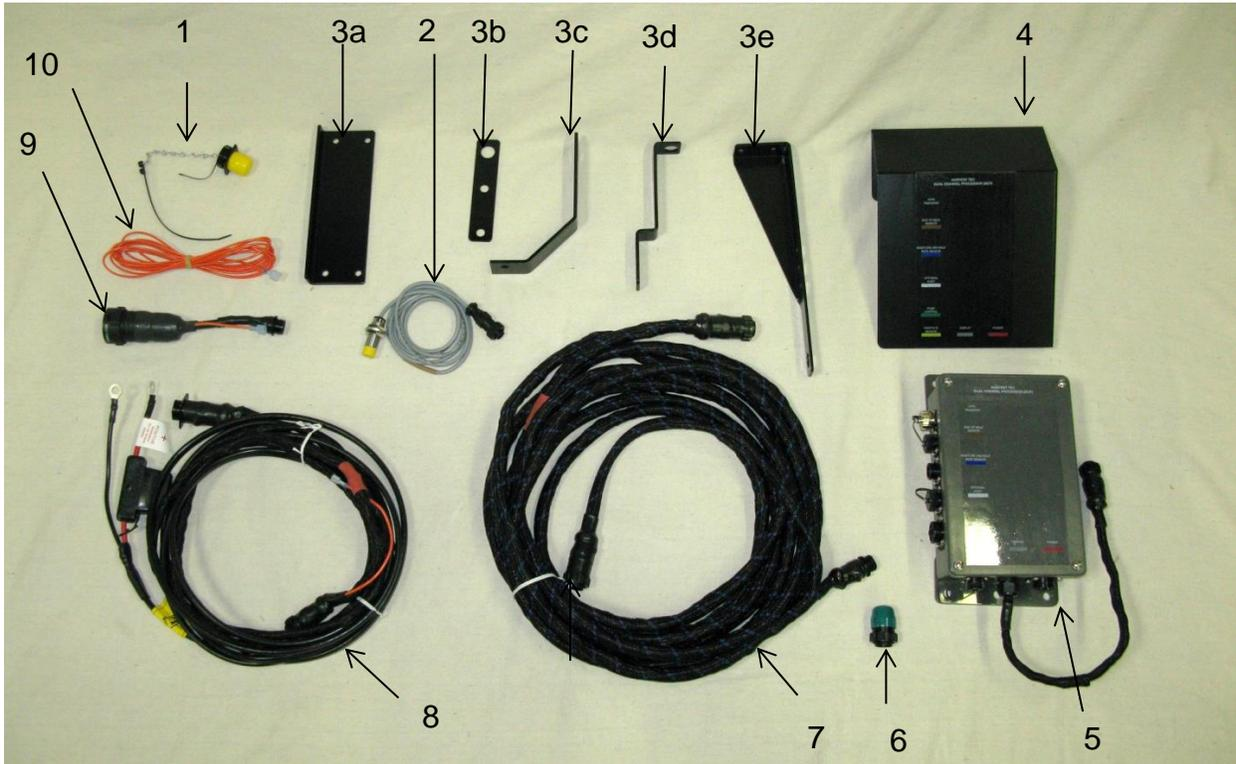

<u>Ref</u>	<u>Description</u>	<u>Part Number</u>	<u>Qty</u>
1	Dust Plugs	006-5651PLUGS	1
2	End of Bale Sensor 600 Series	006-7400	1
3a	Hesston 4755, 4910 EOB Mount	001-4648H	1
3b	EOB Bracket CLAAS 3300	001-4648C	1
3c	Krone EOB Bracket	001-4648K	1
3d	EOB BKT Krone 12130	001-4648K2	1
3e	End of Bale Sensor Bracket	001-4948	1
4	DCP Shield Cover	001-5650X	1
5	DCP Main Control LS 600 AUTO	006-6671LS	1
6	Terminating Connector w/ Green Cap	006-5650Z	1
7	DCP Baler Harness 30'	006-6650LS2	1
8	DCP Tractor Harness	006-6650TM	1
9	Optional ISOBUS Tractor Plug (not included)	006-6670A	1
10	Key Switch Wire	006-5650K	1
11	Bluetooth Receiver	030-6672B	1

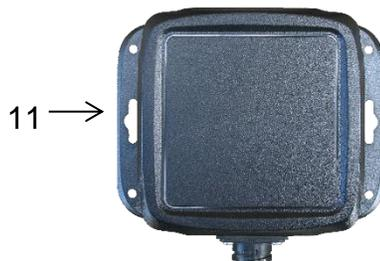

Optional iPad Mini Mounting Kit (030-2014MK)

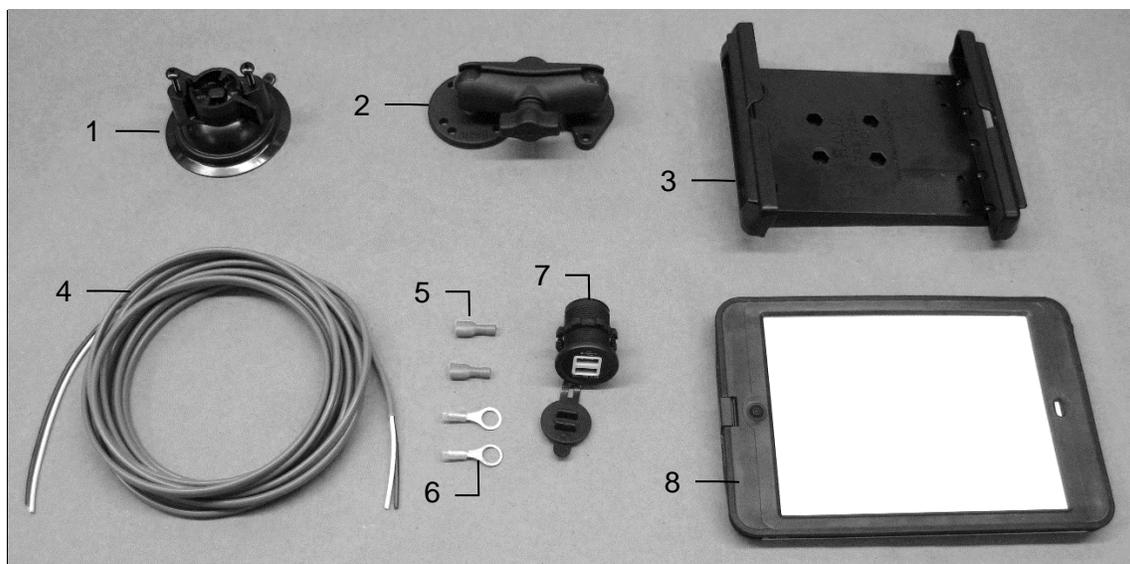

<u>Ref</u>	<u>Description</u>	<u>Part #</u>	<u>Qty</u>
1	Suction cup mount	001-2012SCM	1
2	Ram mount	001-2012H	1
3	iPad Mini spring load cradle (Mini 4)	001-2012SLC	1
4	16 gauge power wire	006-4723P	1
5	Female spade connector	Hardware	2
6	Eye loop connector	Hardware	2
7	iPad Mini Charger 12V	001-2012P	1
8	iPad Mini 4 case	001-2012C4	1
NP	4 amp fuse	Hardware	1
	Mounting Kit Assembly	030-2014MK (Includes All Parts)	

Installation Instructions

1. Identify 12V power source for wires to connect.
 - a. Eye loops included if wiring directly to the battery is desired.
 - b. Test for key power source if preferred to have power to the USB shut off with the key.
2. Once power source is identified, cut wires to desired length.
3. Crimp the two supplied quick connectors onto each the white and black wire.
4. Remove the round locking plastic nut from USB plug before connecting the wires. Black (+) White (-).
5. The wires will then be hooked to the designated terminals on the bottom of the USB plug
6. Drill a 1 1/8" hole in the preferred mounting location. Be sure to clean any sharp edges after drilling.
7. Feed the wires through the mounting hole.
8. If using the round plastic nut to secure plug in place, slide the nut back over the wiring before connecting the wires to powered source.
9. Connect the wires to the identified power source if easier to do so before tightening the plug into place.
10. Tighten plug using either the round plastic nut or mounting plate and two screws, both options supplied.
11. Once connected, hook a USB charging cord into the plug and connect a mobile device/tablet to ensure the plug is operating as you wish (key power working properly if necessary).

NOTE: This plug is not designed to charge two iPads. System damage could occur if this is attempted. System will charge a mobile phone and iPad simultaneously without problem.

Optional iPad Display Kit (030-4670DK)

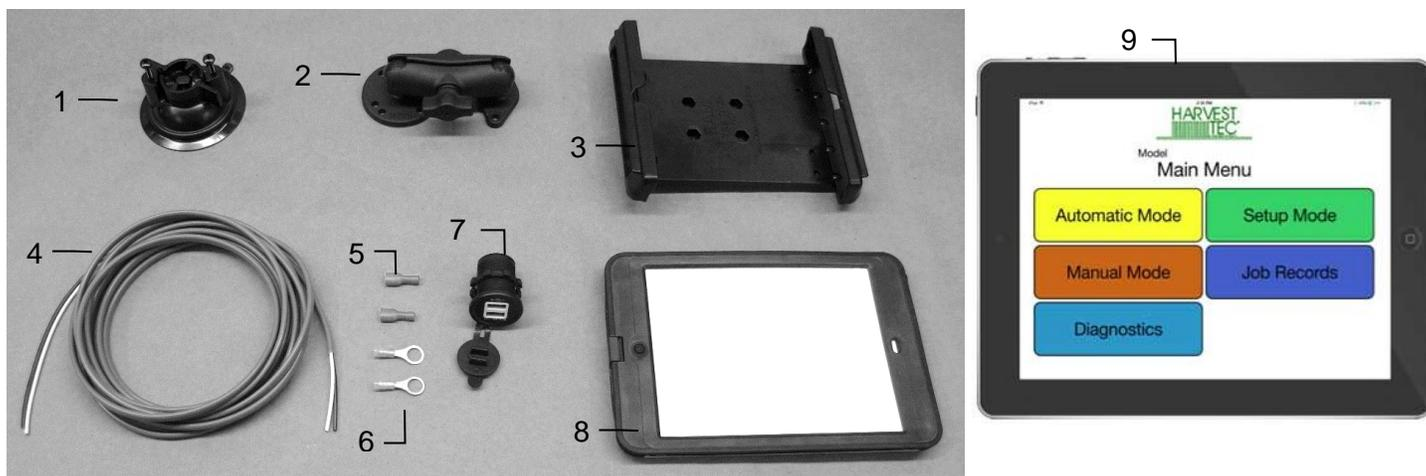

Ref	Description	Part #	Qty	Ref	Description	Part #	Qty
1	Suction cup mount	001-2012SCM	1	7	iPad Mini Charger 12V	001-2012P	1
2	Ram mount	001-2012H	1	8	iPad Mini 4 case	001-2012C4	1
3	iPad Mini spring load cradle (Mini 1,2,3)	001-2012SLC	1	9	iPad Mini 4	006-4670IP	1
4	16 gauge power wire	006-4723P	1	NP	4 amp fuse	Hardware	1
5	Female spade connector	Hardware	2				
6	Eye loop connector	Hardware	2				
					Mounting Kit Assembly	030-4670DK (Includes All Parts)	

Installation Instructions

1. Identify 12V power source for wires to connect.
 - a. Eye loops included if wiring directly to the battery is desired.
 - b. Test for key power source if preferred to have power to the USB shut off with the key.
2. Once power source is identified, cut wires to desired length.
3. Crimp the two supplied quick connectors onto the white and black wire.
4. Remove the round locking plastic nut from USB plug before connecting the wires. Black (+) White (-).
5. The wires will then be hooked to the designated terminals on the bottom of the USB plug
6. Drill a 1 1/8" hole in the preferred mounting location. Be sure to clean any sharp edges after drilling.
7. Feed the wires through the mounting hole.
8. If using the round plastic nut to secure plug in place, slide the nut back over the wiring before connecting the wires to powered source.
9. Connect the wires to the identified power source if easier to do so before tightening the plug into place.
10. Tighten plug using either the round plastic nut or mounting plate and two screws, both options supplied.
11. Once connected, hook a USB charging cord into the plug and connect a mobile device/tablet to ensure the plug is operating as you wish (key power working properly if necessary).

NOTE: This plug is not designed to charge two iPads. System damage could occur if this is attempted. System will charge a mobile phone and iPad simultaneously without problem.

Harvest Tec Inc. Warranty and Liability Agreement

Harvest Tec, Inc. will repair or replace components that are found to be defective within 12 months from the date of manufacture. Under no circumstances does this warranty cover any components which in the opinion of Harvest Tec, Inc. have been subjected to negligent use, misuse, alteration, accident, or if repairs have been made with parts other than those manufactured and obtainable from Harvest Tec, Inc.

Our obligation under this warranty is limited to repairing or replacing free of charge to the original purchaser any part that in our judgment shows evidence of defective or improper workmanship, provided the part is returned to Harvest Tec, Inc. within 30 days of the failure. If it is determined that a non-Harvest Tec branded hay preservative has been used inside the Harvest Tec applicator system where the failure occurred, then Harvest Tec reserves the right to deny the warranty request at their discretion. Parts must be returned through the selling dealer and distributor, transportation charges prepaid.

This warranty shall not be interpreted to render Harvest Tec, Inc. liable for injury or damages of any kind, direct, consequential, or contingent, to persons or property. Furthermore, this warranty does not extend to loss of crop, losses caused by delays or any expense prospective profits or for any other reason. Harvest Tec, Inc. shall not be liable for any recovery greater in amount than the cost or repair of defects in workmanship.

There are no warranties, either expressed or implied, of merchantability or fitness for particular purpose intended or fitness for any other reason.

This warranty cannot guarantee that existing conditions beyond the control of Harvest Tec, Inc. will not affect our ability to obtain materials or manufacture necessary replacement parts.

Harvest Tec, Inc. reserves the right to make design changes, improve design, or change specifications, at any time without any contingent obligation to purchasers of machines and parts previously sold.

Revised 4/17

HARVEST TEC, INC.
P.O. BOX 63
2821 HARVEY STREET
HUDSON, WI 54016
PHONE: 715-386-9100
1-800-635-7468
FAX: 715-381-1792
Email: info@harvesttec.com