

Operation Manual

Model 600A1 & 600UHD1 ***Moisture Sensor Kit for Large Square Balers***



HayBoss™

G2



DECLARATION OF APPLICATION OF ESSENTIAL REQUIREMENTS OF THE DIRECTIVE 2006/42/ EC OF THE EUROPEAN PARLIAMENT AND OF THE COUNCIL OF 17, MAY, 2006 AND OTHER RELEVANT EU DIRECTIVES: The Harvest Tec Hay Moisture Sensor Kit conforms with the Directive and other relevant EU directives.

SERVICE DUTY OF THE PARTIALLY COMPLETED MACHINE: The Harvest Tec Hay Moisture Sensor Kit will only be put into service after installed on a hay baler that has been declared to conform with the Directive.

Noise from the Harvest Tec Moisture Sensor Kit does not exceed 70 dB (A).

Manufacturers Name Plate

Harvest Tec Inc. Manufactured at and correspondence to: 2821 Harvey Street Hudson, WI 54016 USA	
Model	
Build Date	
Serial No.	

PERSON AUTHORIZED TO PROVIDE INFORMATION ON THE MACHINE AND WHO MAKES THIS DECLARATION:

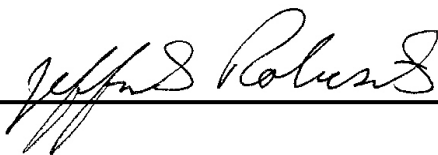

Jeffery S. Roberts, President, Harvest Tec, Inc.

Signed in Hudson, WI, USA on May 21, 2011

Operation Manual Table of Contents

	<u>PAGE</u>
Introduction	3
System Requirements	4
Safety	4
Safety Decals	4
Operation of ISOBUS Monitor	5-10
Baler Monitor Setup	5
System Setup	4-8
Adjust Moisture Alarm	8
Turn On/Off Alarms & Sounds	9
Baler Monitor Setup / View – UHD Baler	10
Connecting the Harnesses to DCP – 600A1	11
Connecting the Harnesses to DCP – 600UHD	12
Common Questions	13
Troubleshooting	14
Controls and Harnesses – 600A1	15
Controls and Harnesses – 600UHD1	16
Starwheel Sensors – 600A1 & 600UHD1	17
Notes	18
Warranty	19

Introduction

Thank you for purchasing the Moisture Monitor System. This system is designed to monitor the moisture of the forage crop and to plug directly into the baler's ISOBUS and display on a the monitor. The Moisture Monitor System offers these advantages:

1. Operation coordinated with baler operation
2. Records kept together
3. Less cab clutter providing better visibility
4. And the system is ready for future updates.
5. Ease of use with all information on one screen

The Moisture Monitor kit includes the following parts: Dual Channel Processor (DCP), Moisture Sensors, Harnesses and Miscellaneous Hardware. For your convenience a parts break down for the model 600A1 is included in the back of this manual. If you do have questions bring this manual into the dealership. They can assist you in ordering the correct replacement parts.

The Moisture Monitoring System can have a complete preservative applicator added as well as the tagging option to enhance the system at any time. Contact your local dealer for more information.

Right and Left sides are determined by facing in the direction of forward travel.

System Requirements

The Baler Processor must have Version 3.3 or higher.

Tools Needed:

- Standard wrench set
- Side cutter
- Standard socket set
- Electric drill and bits
- Standard nut driver set
- Hammer & Center Punch

Safety

Carefully read all safety signs in this manual and on the moisture sensor kit before use. Keep signs clean and clear of obstruction to view. Replace missing or damaged safety signs. Replacement signs are available from your local authorized dealer. See your installation manual under the replacement parts section for the correct part numbers.

Keep your moisture sensor kit in proper working condition. Unauthorized modifications to the moisture sensor kit may impair the function and/or safety of the machine.

Carefully read and understand all safety signs before installing or servicing.

Safety Signs

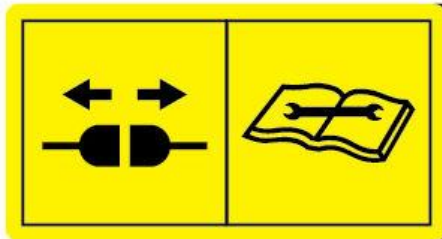

Number 1
Disconnect power before servicing.
Part no. DCL-8003



Number 2
Read and understand the operator's manual before
using or working around the equipment.
Part no. DCL-8000

Operation of the ISOBUS Monitor

The ISOBUS Monitor utilizes a combination of soft keys, number menus, and the scroll wheel on the upper right side of the actual monitor to make selections. Selections are made by scrolling the Thumb Wheel and pressing in once the selection is highlighted. All buttons are labeled and color coded.



Baler Monitor Setup

At any time after initial Start Up/Power On the green “uploading data” status bar (A) will begin to fill.

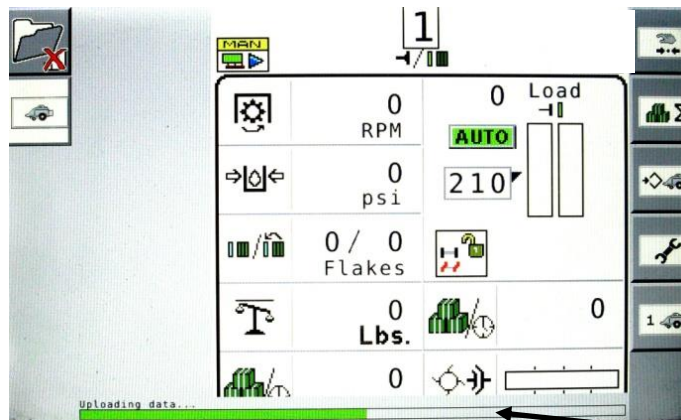

A

System Setup

1. To view moisture from the 600A1 Moisture Sensor begin setup at the main baler screen. Select the **WRENCH** icon (B) which is the fourth icon down on the right side of screen in selection menu.

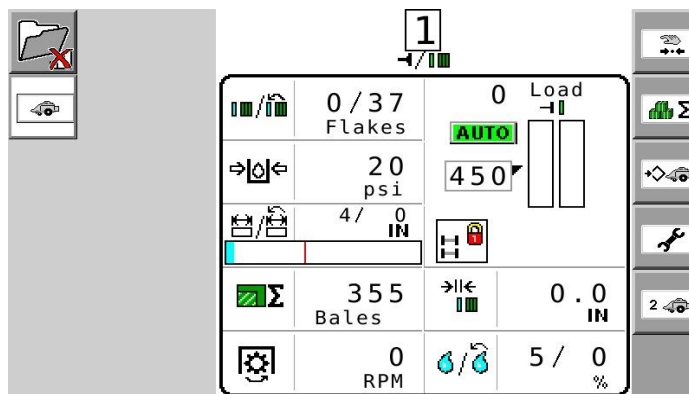

B

- The service screen displayed below should appear. Select the **Next Screen** icon (C) located at the bottom of the right selection menu.

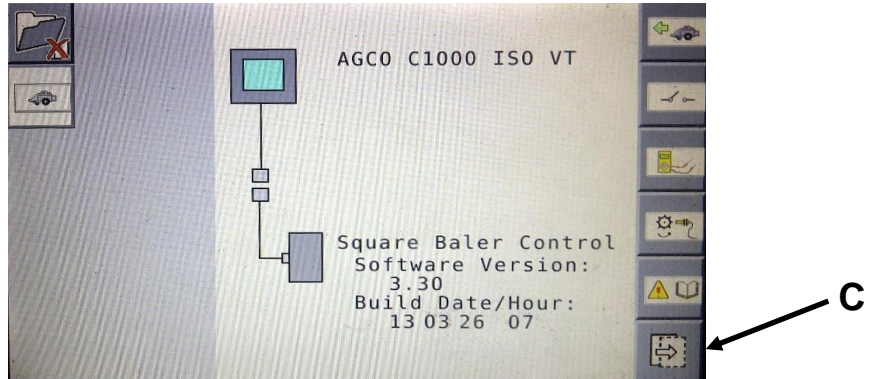

- A similar screen will appear with a different menu options on the right side of the screen. Press the **A B** icon (D) located at the top right of the selection menu.

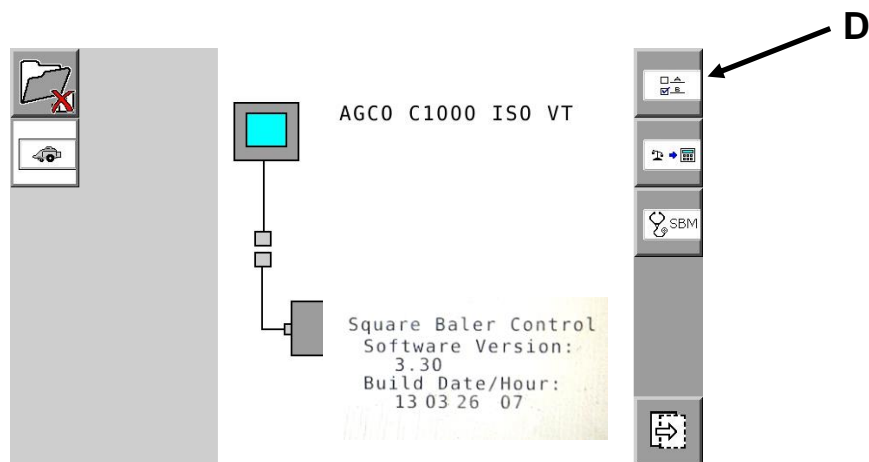

- The A B screen will appear. Next select the **A B 2** (E) icon which is the second from the top on the far right selection menu.

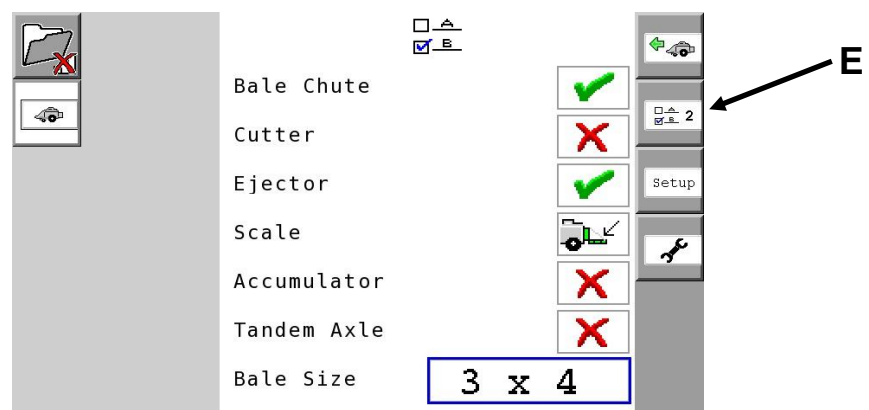

- The A B 2 screen will appear. The **Harvest Tec** On/Off selection icon can now be selected. To turn the Harvest Tec Moisture Sensor On (signified by a **green check mark**) or Off (signified by a **red X**) navigate to the box and select (F) by pressing the **Scroll Wheel**. Once the Harvest Tec Moisture Sensor has been turned On/Off you can navigate back to the main baler work screen by pressing the **BALER** (G) icon on the top right of the selection menu.

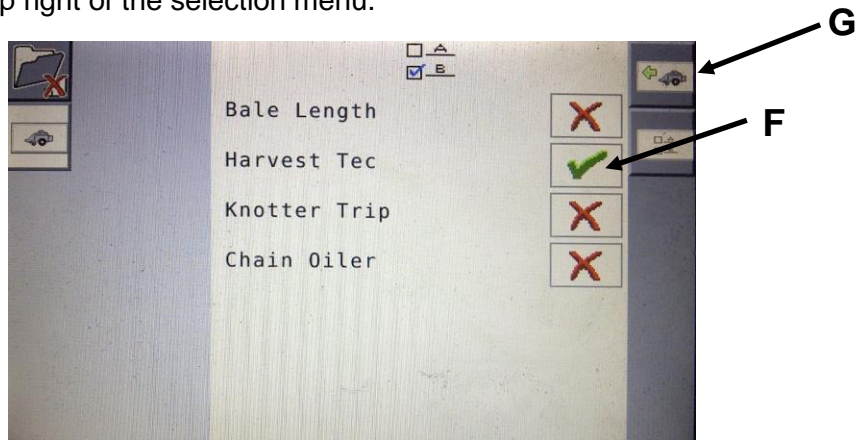

- The main baler work screen will appear. Select the **container** (H) where you would like to view the moisture information on the baler run screen. *Note: This can be done on the primary or secondary baler work screen. The screen has been or can be customized for viewing containers or options as you would like and as guided in the baler manual.*

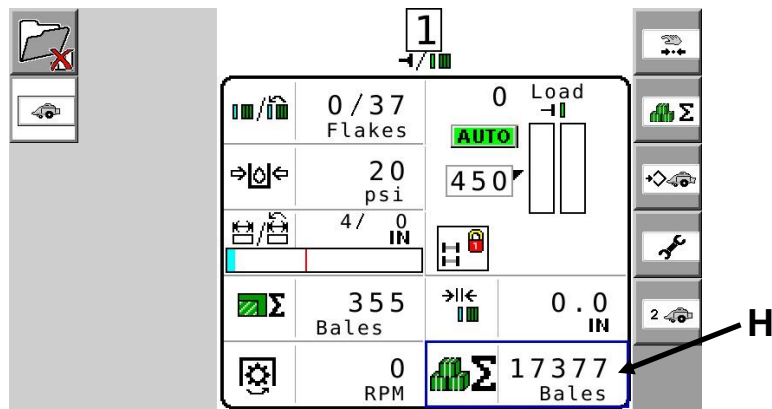

- Once the user has selected the container they would like to change, a **drop down list** (I) will appear. The **Moisture option** (J) should be at the bottom of the drop down selection list.

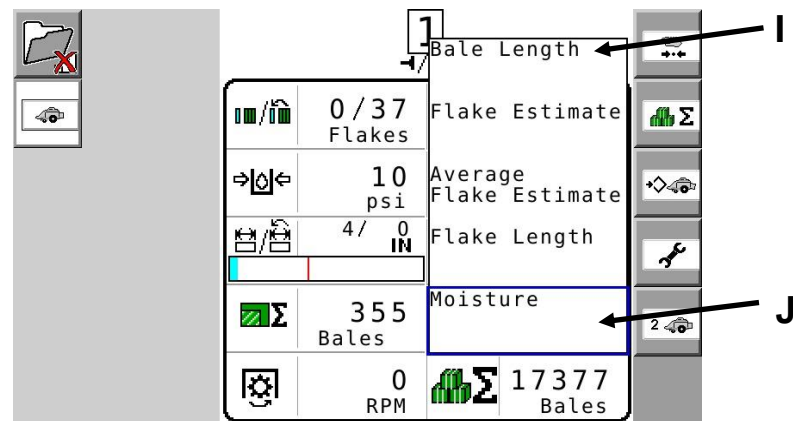

- The Moisture container will have a red background until HayBoss G2 system is put in Manual Mode or Auto Mode. The two values indicated in the moisture option are as follows: **current moisture / last bale average moisture** (K).

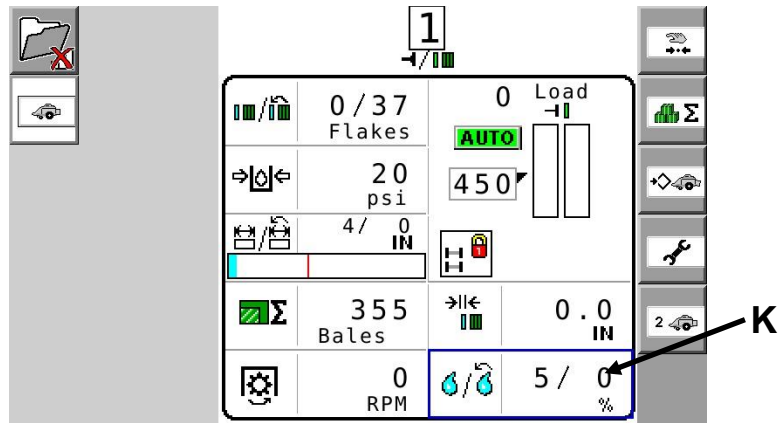

Adjust the Moisture Alarm

- From the main baler screen, select the third icon down the right selection menu that shows a **diamond beside a baler** (L).

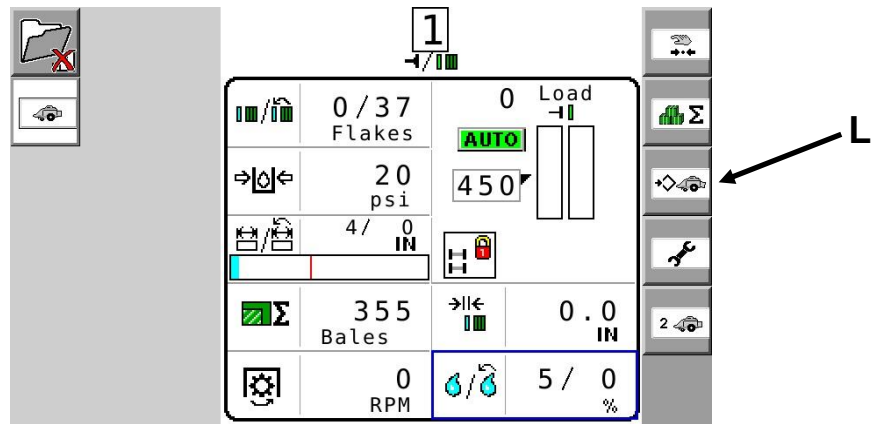

- To adjust the moisture alarm set point select the **box option to the right of the moisture droplets** (M) and adjust to the desired moisture limit. To return to the baler work screen, press the baler icon at the top right of the selection menu (N). When the moisture is higher than alarm setting the audible alarm will sound (if turned on) and moisture values on screen will display with red background.

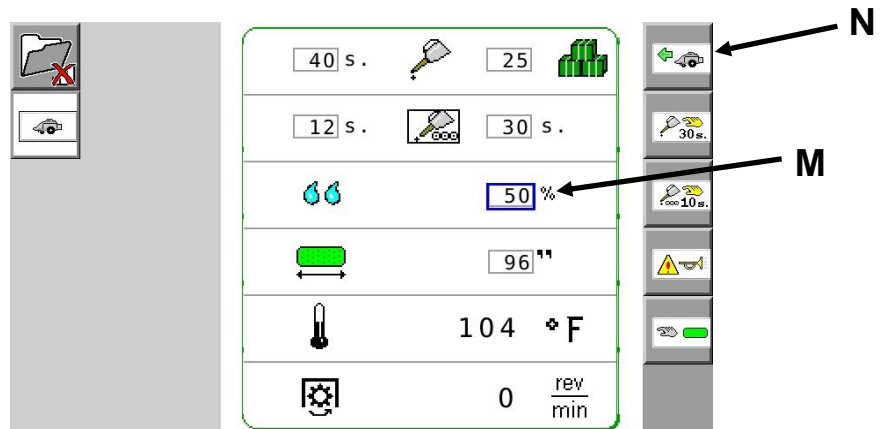

Turn On/Off Alarms & Sounds

- From the main baler work screen select the third icon down the right selection menu that shows a **diamond beside a baler** (O).

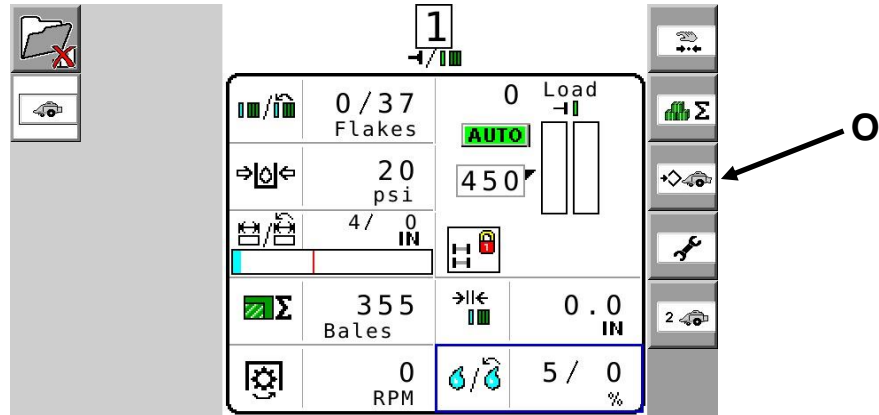

- Select fourth icon down on the right selection menu showing a **bugle beside an alarm icon** (P).

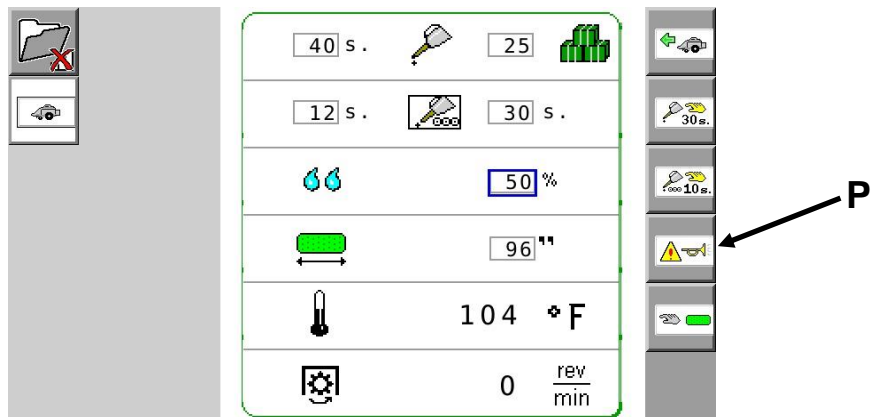

- The alarm screen should now be displayed. All alarms can be silenced before they are ever heard. This can be done by selecting the **Peak Moisture** icon (Q) and turning the alarm On/Off. To return to the baler work screen, press the baler icon located at the top right of the selection menu. If the moisture is higher than the alarm setting the moisture values will be displayed with a red background but there will be no audible alarm if this is turned off.

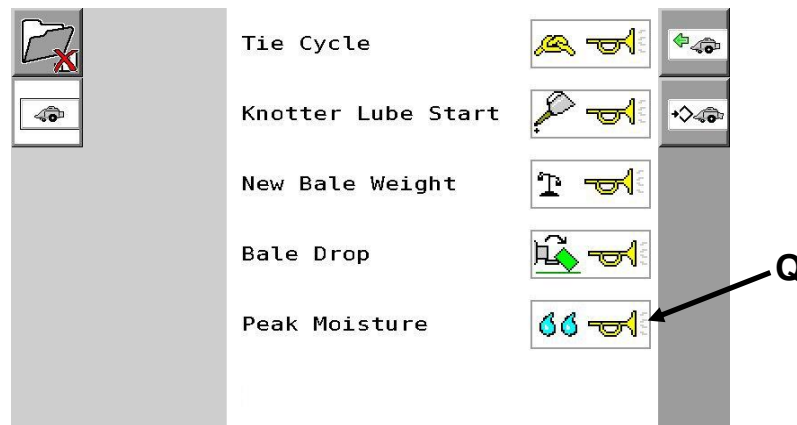

Baler Monitor Setup / View – UHD Baler Only

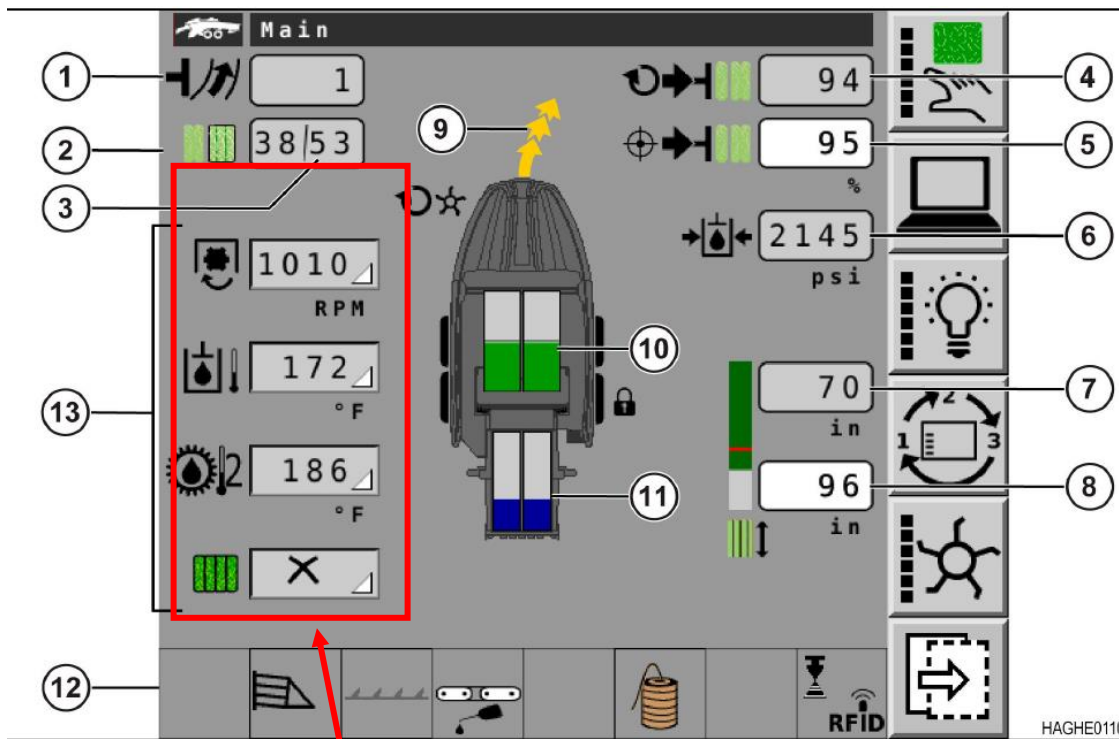

These four containers can be configured by the operator. In the selectable list are the items for your system. They are Current moisture, average moisture, applicator target rate, and applicator actual rate. When moisture is above your alarm setpoint it will show the moisture value with a red background.

This container is reserved for the moistures system. It shows the tagger status and applicator status. When moisture is above your setpoint it will turn the background red and show the percent moisture icon in the upper right corner.

Background turns red when your system is on main work screen. Icon Blinks when the system is paused.

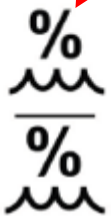

Current Moisture

Average Moisture



Preservative Applicator Target Rate

Preservative Applicator Actual Rate



Moisture System On. The icon will flash when the system is paused

Moisture System Off



Tagger Installed and On. This icon will flash when a tag is applied. There is also a % symbol that shows in the top right corner if the bale moisture goes over the limit

Connecting the Harnesses to the DCP – 600A1

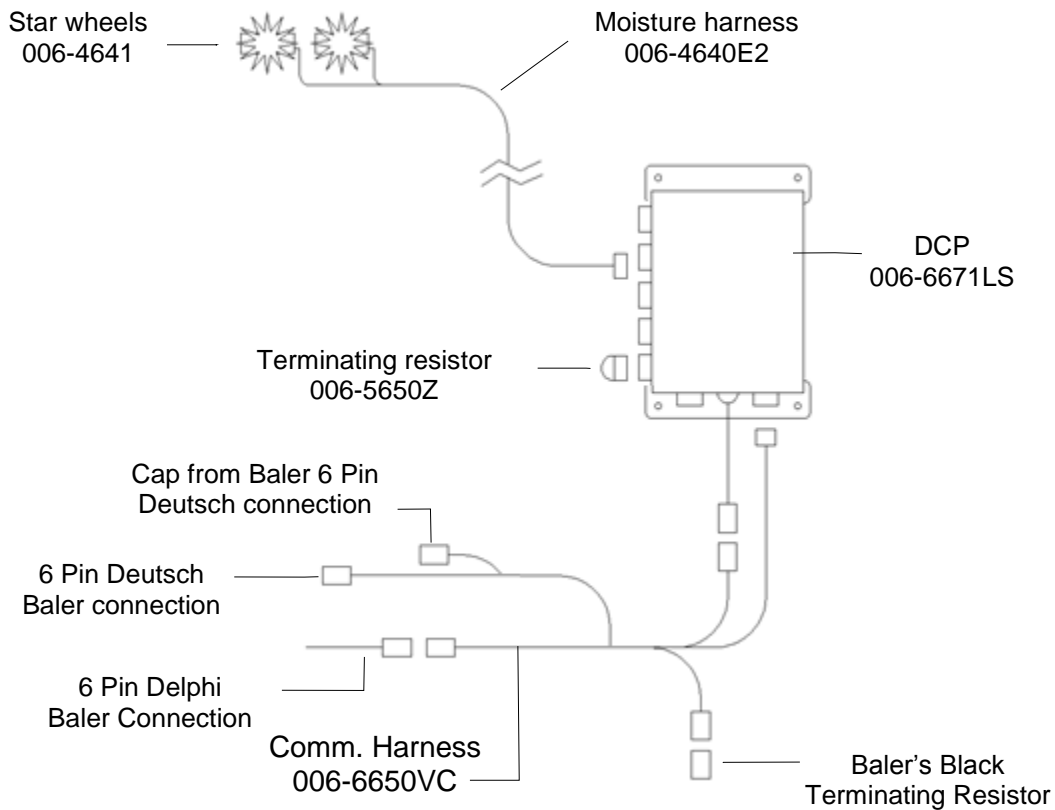

1. Install the green capped terminating resistor (006-5650Z) to the Dual Channel Processor (DCP).
2. Route the communication harness (006-6650VC) from the baler to the DCP. Attach the harness to the whip harness coming off the base of the DCP. Secure harness from DCP to baler communication port.
3. Install the baler's black terminating resistor to the open end of the communication harness (006-6650VC) next to the DCP.
4. Remove cap from the 6 pin Deutsch connection located at the back of the baler behind the right fender.
5. Connect harness (006-6650VC) 6 Pin Deutsch connection to baler connection at back of the baler.
6. Install the moisture harness (006-4640E2) into the DCP at the port marked Moisture Sensor. Secure harness from DCP to star wheels.

Connecting the Harnesses to the DCP – 600UHD1

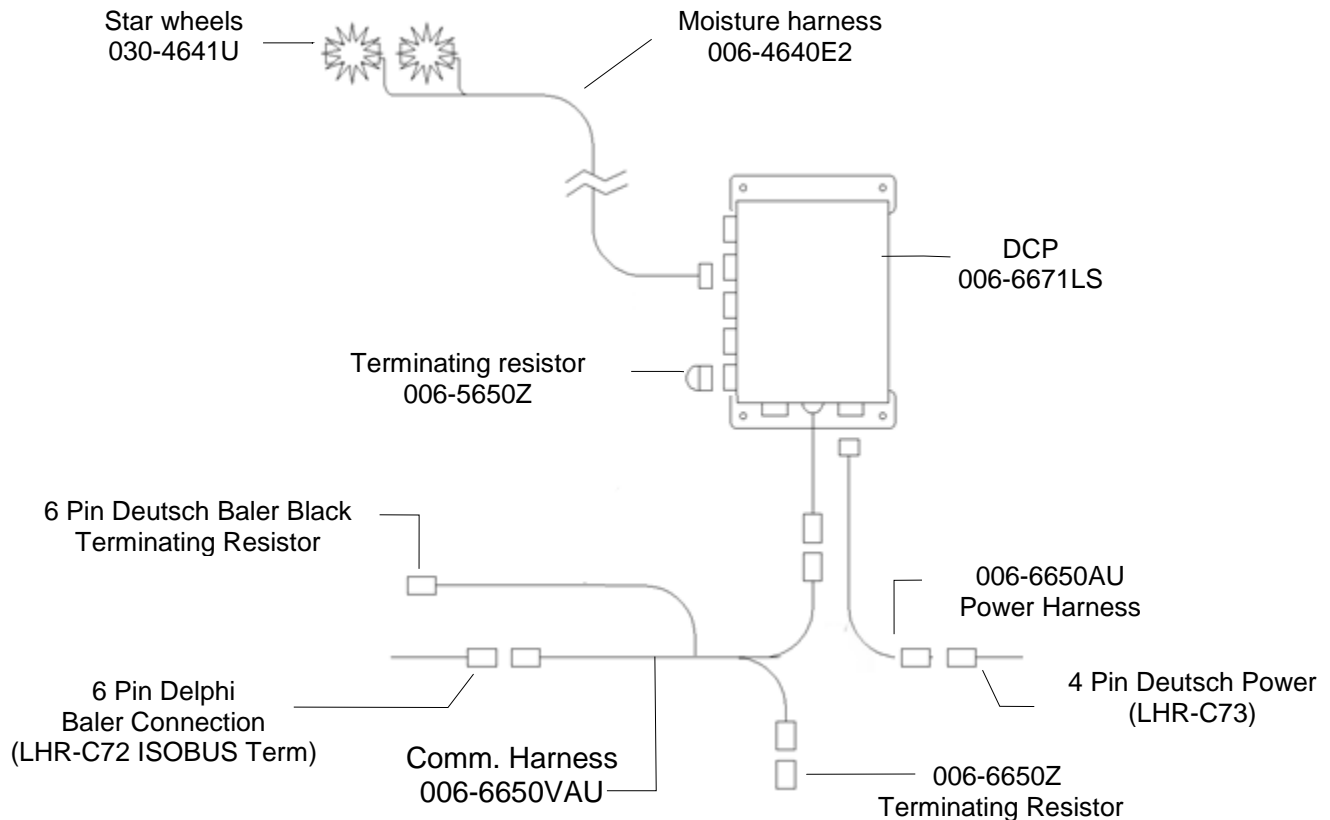

1. Install the green capped terminating resistor (006-5650Z) to the Dual Channel Processor (DCP).
2. Route the communication harness (006-6650VAU) from the baler to the DCP. Attach the harness to the whip harness coming off the base of the DCP. Secure harness from DCP to baler communication port.
3. Install the baler's black terminating resistor to the open end of the communication harness (006-6650VAU) next to the DCP.
4. Remove cap from the 4 pin Deutsch connection located at the back of the baler.
5. Connect harness (006-6650VAU) 4 Pin Deutsch connection to baler connection at back of the baler for power (LHR-C73).
6. Install the moisture harness (006-4640E2) into the DCP at the port marked Moisture Sensor. Secure harness from DCP to star wheels.

Common Questions

1. How do I turn the system on/off?

Turn the key in the tractor to the ON position. The ISOBUS Monitor will turn on, and the baler, on 600A1 working screen tabs, will be viewable. Turn the system off by turning the tractor key OFF.

2. How to get in the LBS/TON, MC%, and TONS/HR menus?

In the Main Menu press the SETUP MODE key. From this screen you can change your alarm settings and bale rate settings. See SETUP INSTRUCTIONS in the Operations Manual for a detailed explanation of this process.

3. The moisture content displays “LO” or “HI” all the time.

When the moisture content display does not change frequently while baling, there is likely a faulty star wheel connection. One of the first places to check is inside the white star wheel block. Check to see if the electronic swivel is in the star wheel shaft and check to see that the star wheel shaft is not working out of the block. Also, check all star wheel wires and connectors to see if there is a continuity or grounding problem.

4. Should the battery connections be removed before jump starting or charging a battery?

Yes. Anytime the tractor will have voltage going up rapidly the connections should be removed.

5. Can the Harvest Tec 600A1 be updated for preservative or a tagger?

Yes. A conversion kit must first be purchased.

6. Bale scale does not give a consistent reading.

Baling on rough terrain or hills can cause the scale to give an inaccurate reading. Turn Bale Scale option OFF in the Bale Rate Screen and use AVG Bale Weight reading as weight of bale.

*Conversion package 665A1 needed to add the following systems:

Add Preservative Application:

5004518B	Standard→ 2150-2290
5004519B	Cutter→ 2150-2290
5004527B	Packer → 2150-2250
5004530B	2170-2270 XD with Cutter

Add Tagger

850

Add Dye Spray Marker

0840

Troubleshooting

Problem	Possible Cause	Solution
Moisture reading errors (high or low)	1. Wire disconnected or bad connection between star wheels and DCP	1. Reconnect wire.
	2. Low power supply to DCP	2. Check voltage at box. (Min of 12 volts required.) See Diagnostics section of manual.
	3. Dry hay lower than 8% moisture or wet hay over 75%.	3. System reads 8-70% moisture.
	4. Ground contact with one or both star wheels and baler mounted processor.	4. Reconnect.
	5. Short in wire between star wheels and DCP.	5. Replace wire.
	6. Check hay with hand tester to verify.	6. Contact Harvest Tec if conditions persist.
Moisture readings erratic.	1. Test bales with hand tester to verify that DCP has more variation than hand tester.	
	2. Check all wiring connections for corrosion or poor contact.	2. Apply dielectric grease to all connections.
	3. Check power supply at tractor. Voltage should be constant between 12 and 14 volts.	3. Install voltage surge protection on tractors alternator.
Terminal reads under or over power.	1. Verify with multi-meter actual voltage. Voltage range should be between 12-14 volts.	1. Clean connections and make sure applicator is hooked to battery. See Diagnostics section of manual.

600A1 Controls and Harnesses

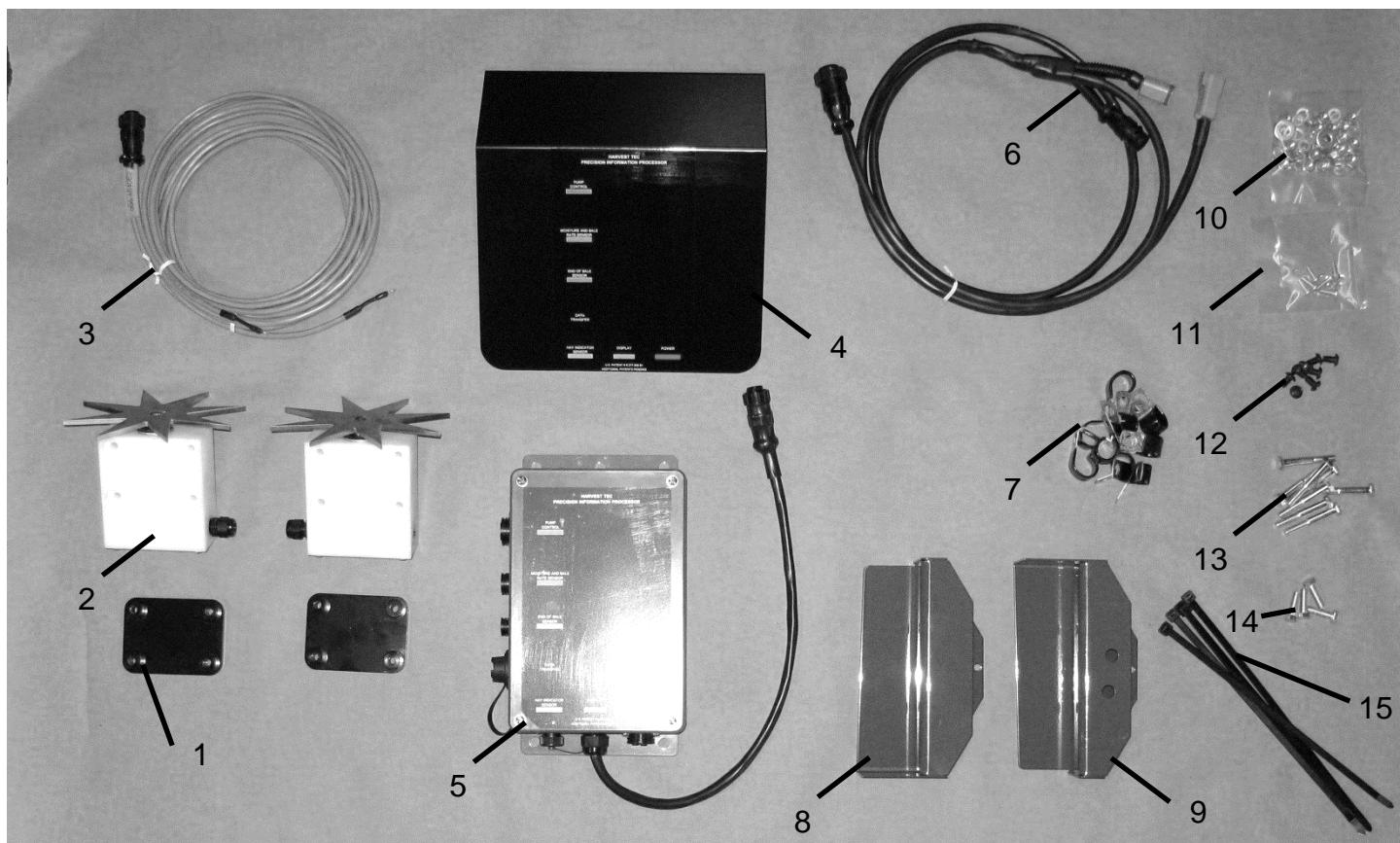

<u>Ref #</u>	<u>Description</u>	<u>Part #</u>	<u>Qty</u>	<u>Ref #</u>	<u>Description</u>	<u>Qty</u>
1	Star wheel spacer	001-6707E	2	10	5/16" nuts	22
2	Star wheels	030-4641	2	10	5/16" lock washers	14
3	Moisture harness	006-4640E2	1	10	5/16" flat washer	4
4	DCP cover	001-5650X	1	11	10/24 x 5/8" PHS	8
5	Dual Channel Processor	006-6671LS	1	11	10/24 lock washers	8
6	Comm. harness	006-6650VC	1	12	5/16" x 1/2" BHCS	8
7	Wire clips	008-9018	9	13	5/16" x 2-1/4" hex bolt	8
8	Twine diverter	001-4645H	1	14	5/16 x 1" hex bolt	4
9	Twine diverter	001-4644H	1	15	12" cable ties	5
NP	Terminating resistor	006-5650Z	1			

600UHD1 Controls and Harnesses

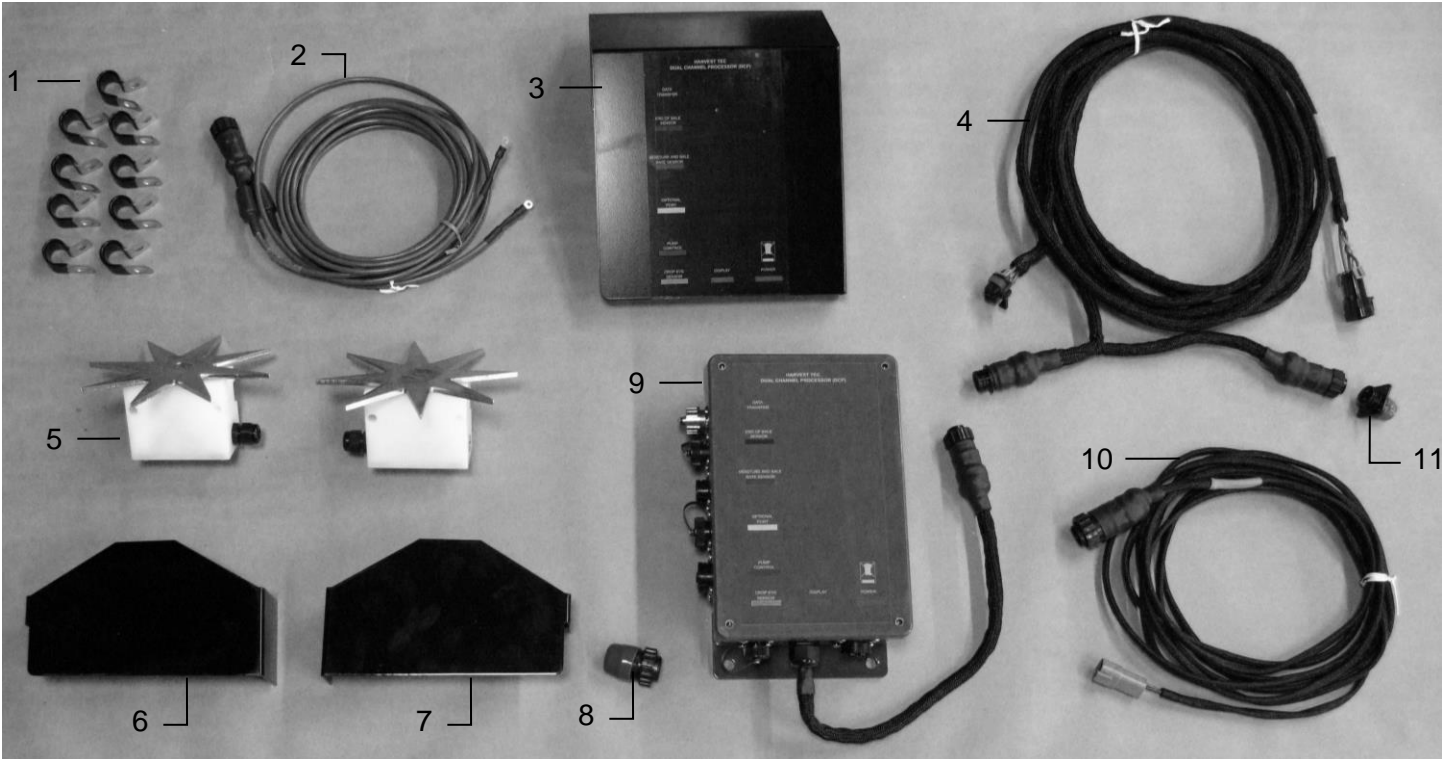

<u>Ref #</u>	<u>Description</u>	<u>Part #</u>	<u>Qty</u>	<u>Ref #</u>	<u>Description</u>	<u>Part #</u>	<u>Qty</u>
1	Jiffy Clips	008-9018	6	7	Left Twine Diverter	001-4645	1
2	Moisture Harness	006-4640E2	1	8	Resistor (Green)	006-5650Z	1
3	DCP Cover	001-5650X	1	9	Processor (DCP)	006-6671LS	1
4	UHD Integration Harness	006-6650VAU	1	10	UHD Pwr Harness	006-6650AU	1
5	UHD Baler Starwheel	030-4641U	2	11	Terminator (Red)	006-6650Z	1
6	Right Twine Diverter	001-4644	1				

Star Wheel Sensors – 600A1

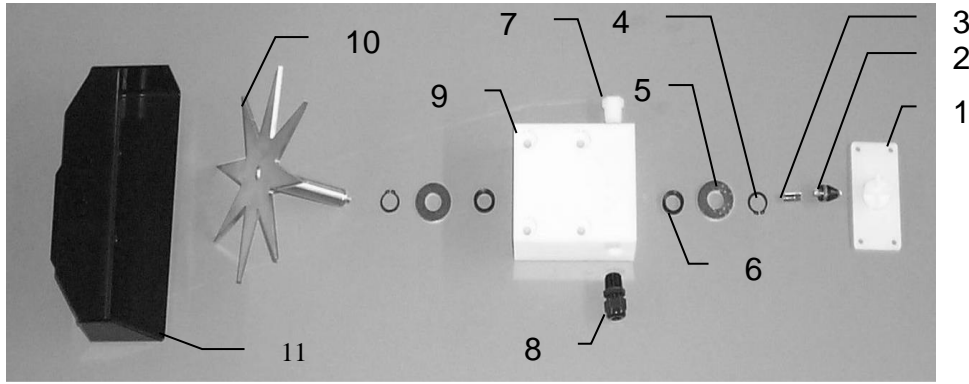

<u>Ref #</u>	<u>Description</u>	<u>Part#</u>	<u>Qty</u>	<u>Ref #</u>	<u>Description</u>	<u>Part#</u>	<u>Qty</u>
1	Block cover	006-4641B	2	9	Star wheel block	006-4641A	2
2	Electronic swivel	006-4642A	2	10	Star wheel sensor	030-4641C	2
3	Swivel insert	w/ Ref # 10	2	11	Twine guard-left for Agco	001-4645H	1
4	Snap ring (per side)	006-4641K	2		Twine guard-Right for Agco	001-4644H	1
5	Washer (per side)	w/006-4641K	2	1-10	Star wheel assembly	030-4641	2
6	Dust seal (per side)	w/006-4641K	2	12	Spacer plate for Agco	001-6707E	2
7	Plug fitting	003-F38	2				
8	Wiring grommet	008-0821A	2				

Star Wheel Moisture Sensors – 600UHD1

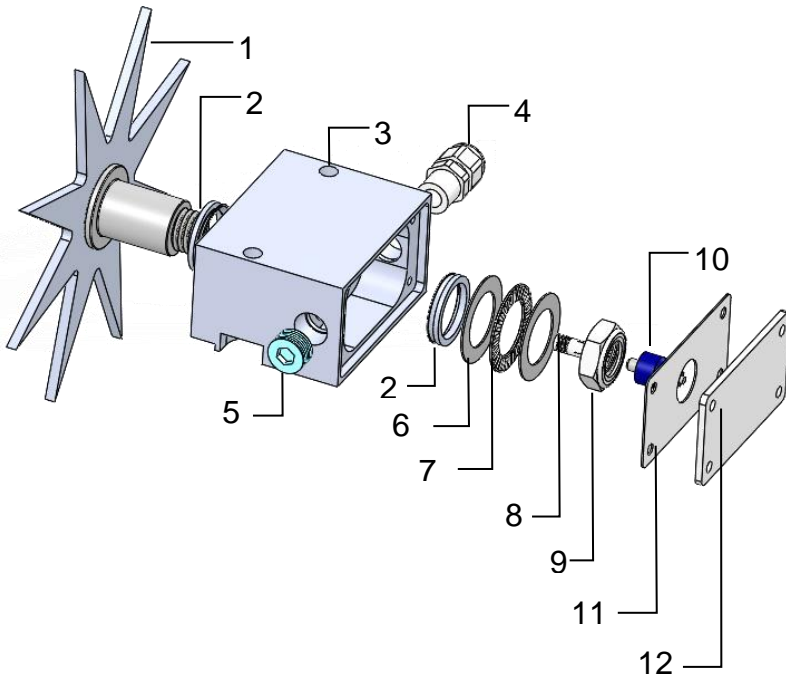

<u>Ref</u>	<u>Description</u>	<u>Part#</u>	<u>Qty</u>
1	Univ Star Wheel	006-4641S	1
2	Dust Seal	006-4641DSL	2
3	Univ Star Block	006-4641Q	1
4	3/8" NPT Cable Grip	008-0821A	1
5	3/8" NPT Plug	003-F38	1
6	Thrust Washer	006-4641TA	2
7	Thrust Bearing	006-4641TB	1
8	Swivel Insert	006-4642B	1
9	3/4" Short Nut	006-4641U	1
10	Rotary Swivel	006-4642A	1
11	Cover Gasket	006-4641RG	1
12	Univ Block Cover	006-4641R	1
	Complete Assembly	030-4641U	2

Notes

Harvest Tec Inc. Warranty and Liability Agreement

Harvest Tec, Inc. will repair or replace components that are found to be defective within 12 months from the date of manufacture. Under no circumstances does this warranty cover any components which in the opinion of Harvest Tec, Inc. have been subjected to negligent use, misuse, alteration, accident, or if repairs have been made with parts other than those manufactured and obtainable from Harvest Tec, Inc.

Our obligation under this warranty is limited to repairing or replacing free of charge to the original purchaser any part that in our judgment shows evidence of defective or improper workmanship, provided the part is returned to Harvest Tec, Inc. within 30 days of the failure. If it is determined that a non-Harvest Tec branded hay preservative has been used inside the Harvest Tec applicator system where the failure occurred, then Harvest Tec reserves the right to deny the warranty request at their discretion. Parts must be returned through the selling dealer and distributor, transportation charges prepaid.

This warranty shall not be interpreted to render Harvest Tec, Inc. liable for injury or damages of any kind, direct, consequential, or contingent, to persons or property. Furthermore, this warranty does not extend to loss of crop, losses caused by delays or any expense prospective profits or for any other reason. Harvest Tec, Inc. shall not be liable for any recovery greater in amount than the cost or repair of defects in workmanship.

There are no warranties, either expressed or implied, of merchantability or fitness for particular purpose intended or fitness for any other reason.

This warranty cannot guarantee that existing conditions beyond the control of Harvest Tec, Inc. will not affect our ability to obtain materials or manufacture necessary replacement parts.

Harvest Tec, Inc. reserves the right to make design changes, improve design, or change specifications, at any time without any contingent obligation to purchasers of machines and parts previously sold.

Revised 4/17

HARVEST TEC, INC.
P.O. BOX 63
2821 HARVEY STREET
HUDSON, WI 54016
PHONE: 715-386-9100
1-800-635-7468
FAX: 715-381-1792
Email: info@harvesttec.com