

Operation Manual

Model 696

100 & 110 Gallon Preservative Applicator



*Equipment and Products
for Quality Hay.™*

P.O. Box 63 • 2821 Harvey Street • Hudson, WI 54016
800-635-7468 • www.harvesttec.com

DECLARATION OF INCORPORATION



MANUFACTURER:

Harvest Tec Inc.
2821 Harvey St.
P.O. Box 63
Hudson, WI 54016, U.S.A.

REPRESENTATIVE ESTABLISHED IN COMMUNITY: Profitable Farming Company
Middle Barlington, Roborough
Winkleigh, Devon, EX19 8AG
ENGLAND

The person above certifies and declares that:

VIRTUAL MACHINE: Equipment mounted on a farm press and for the application of inoculants onto forage crops.

MODEL: 696-16-OPR-BLE

BRAND: Harvest Tec

SERIAL NUMBER:

This application preservatives for hay Harvest Tec system meets the Directive 2006/42/EC of the European Parliament and the Council of 17 May 2006 and other applicable European Directives including Directive 2004/108/EC on the Electromagnetic compatibility.

The application of preservatives for hay Harvest Tec system will be turned on after being installed on a farm press has been declared in conformity with the Machinery Directive.

Person in the community authorized to provide information on the partly completed machinery and making this statement:

Richard Snell, President, Profitable Farming Company

Signed on May 21, 2011: Middle Barlington, Roborough

Winkleigh, Devon, EX19 8AG

ENGLAND

Harvest Tec Model 696 Operations Table of Contents

	<u>PAGE</u>
Introduction	5
System Requirements	5
Installation Kit Reference Chart	5-6
Safety	6
Safety Decals	7
Safety Sign Locations	8
Preparing the Applicator for Operation	9-10
Filling the tank	9
Connecting power and communication harnesses	10
Operation of the main ball valve	10
Krone ISOBUS Integration (optional)	
Bluetooth Operation	11-22
Downloading the Harvest Tec App	11
Shutting Down the Hay App	12
Bluetooth Receiver	12
Device Selection	13
Manual Selection & Recommended Preservative	14
Tab Descriptions	15
Screen Menus	16-22
Setup Mode	17-20
Software Versions	20
Job Records	21-22
First time and Annual Startup	23
Setting up System for Operation	24-32
Application Rate	24
Baling Rate	24
Bailing Rate Settings – Baler Sensors	25
RFV Setup	26
Operating Instructions	27-32
Automatic Mode	27
Manual mode	28
Job Records	29
Download Job Records	30
Export Job Records	31-32
Wiring Diagram – Krone ISOBUS Integration (optional)	33
Wiring Diagram	34
Maintenance	35-37
Maintenance Schedule, Diagnostics, Filter Bowl Cleaning	35
Tips & tip screen cleaning	36
Tank Lid Cleaning & Dielectric grease connections	37
Rebuild pumps & Battery connections	37
Check valves & Miscellaneous maintenance	37
Winter Storage	38
Status Alerts	38
Pin Outs	39-41
Common Questions	42
Troubleshooting	43-44
iPad Troubleshooting	45
Parts Breakdown	46-79
Tank, Saddle & Legs 100 Gal Tank	46
Tank, Saddle & Legs 110 Gal Tank	46-48
Pump manifold	49
Star wheel sensors	50

Table of Contents

	<u>PAGE</u>
Control boxes and wiring harnesses	51
Hose and drain/fill line	52
Optional iPad Mini Mounting Kit (030-2012MK)	53
Optional iPad Display Kit (030-2670DK)	54
Installation kits specific to balers	
Install Kit 4438B	55
Install Kit 4439B	56
Install Kit 4490B	57
Install Kit 4491B	58
Install Kit 4492B	59
Install Kit 4494B	60
Install Kit 4495B & 4528B	61
Install Kit 4497B & 4529B	62
Install Kit 4498B	63
Install Kit 4499B	64
Install Kit 4500B	65
Install Kit 4501B	66
Install Kit 4509B	67
Install Kit 4510B	68
Install Kit 4511B	69
Install Kit 4514B	70
Install Kit 4515B	71
Install Kit 4525B	72
Install Kit 4525JB	73
Install Kit 4537B	74
Install Kit 4539B	75
Install Kit 4540B	76
Install Kit 4540BX	77
Install Kit 4541B	78
Install Kit 4541BX	79
Notes	80-82
Warranty statement	83

Introduction

Thank you for purchasing a Harvest Tec Model 696 Hay Preservative Applicator. This 696 applicator system has been designed to be operated through an Apple iPad (not included) using the Hay App. As well as the option to plug directly into most tractors that have an ISOBUS Monitor. The 696 Applicator System offers these advantages by operating through an Apple iPad:

1. Large bright, clear, colorful display
2. More durable and can be read in bright sunlight
3. Wireless connection in cab
4. Can be used for multiple other uses than just the applicator display
5. Option to tie-into the tractor ISOBUS system

The 696 Hay Preservative Applicator System is designed to apply buffered propionic acid to the forage crop as it is baled and will adjust the rate of application based on moisture and tonnage of the crop being harvested. The model 696 base kit includes: tank, frame, pumps, hose, and the Dual Channel Processor (DCP). This manual will take you through the steps for installing the applicator. If you are unsure about installing the system after consulting this manual, contact your local authorized dealership for additional assistance. If you are in need of parts for the system please see the parts breakdown in the back of this manual and contact your local authorized dealer to order the parts. This applicator is designed to apply Harvest Tec buffered propionic acid.

Right and Left sides are determined by facing in the direction of forward travel.

***Requirement to run iPad option are 3rd Generation iPad (2012) or newer, running the current iOS operating system or one version previous. Krone ISOBUS integration requires harness 006-6650VAK.**

If choosing to operate the unit through the ISOBUS monitor, pn 006-6670A will need to be ordered through your local equipment dealer. 2018 Krone balers (and beyond) Serial Number 976909 will need pn 006-6650VAK.

Attention:

For kits on 2010 Krone HDP balers and newer Krone part number 20 073 194 0 must be ordered to mount the star wheels.

Please see attached supplemental manual for further instructions.

Installation Kit Reference Chart

BALER MAKE	MODEL	INSTALL KIT
AGCO Hesston	4750 - 4755	030-4490B
	4760	030-4494B
	4790	030-4492B
	4900 - 4910	030-4491B
	4760 roto-cutter	030-4500B
	4790 roto-cutter	030-4501B
	7430	030-4494B
	7430 roto-cutter	030-4500B
	Case IH	8570 - 8575
8585		030-4492B
8580 - 8590		030-4491B
LBX331 - 332 STD or packer		030-4495B
LBX431 - 432 STD or packer		030-4495B
LBX331 -332 roto-cutter		030-4497B
LBX431 - 432 roto-cutter		030-4497B
LB333 - 433 STD or packer		030-4495B
LB333 - 433 roto-cutter		030-4497B
LB 433 STD or packer (2011-2012)		030-4528B

	LB 433 roto-cuter (2011-2012)	030-4529B
Challenger	LB33	030-4494B
	LB34	030-4492B
	LB44	030-4491B
Claas	2200/1200/3200/3400	030-4499B
	2100	030-4509B
	3300	030-4537B
Krone	VFS 88	030-4498B
	VFS 88 cutter	030-4495B
	VFS 128	030-4498B
	VFS 128 cutter	030-4495B
	890-12130 XC	030-4514B
	890-12130	030-4515B
	BP 4x4, BP 4x4 HS	030-4539B
	890 XC High Speed	030-4540B
	1270,1290, 1290HDP, 4x4 XC HS	030-4541B
Kuhn	LSB 870 - 890	030-4510B
	LSB 1270 - 1290	030-4511B
	Omni-cut	030-4525B
Massey	2050	030-4494B
Ferguson	2050 roto-cutter	030-4500B
New Idea	7233	030-4490B
	7234	030-4492B
	7244	030-4491B
	7333	030-4494B
New Holland	590 - BB9080 STD or packer	030-4495B
	BB940 - BB9080 roto-cutter	030-4497B
	BB9080 STD or packer (2011-2012)	030-4528B
	BB9080 roto-cutter (2011-2012)	030-4529B
Taarup	6570 - 6570 OC	030-4510B
	6670 - 6690 OC	030-4511B
Vermeer	SQ2731	030-4438B
	SQ3347	030-4439B
Vicon	LB 8200	030-4510B
	LB 12200	030-4511B

Safety

Carefully read all the safety signs in this manual and on the applicator before use. Keep signs clean and visible. Replace missing or damaged safety signs. Replacement signs are available from your local authorized dealer. See your installation manual under the replacement parts section for the correct part numbers.

Keep your applicator in proper working condition. Unauthorized modifications to the applicator may impair the function and/or safety of the machine.

Carefully read and understand all of the baler safety signs before installing or servicing the baler. Always use the supplied safety equipment on the baler to service the applicator.

Safety Decals

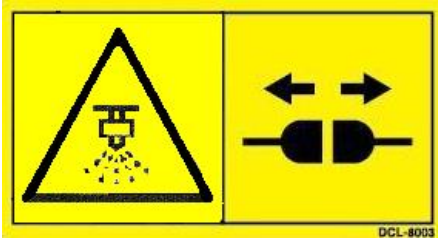

Number 1
Spraying hazard. Disconnect power before servicing the applicator
Part no. DCL-8007



Number 2
Falling hazard. Do not step in this area.
Part no. DCL-8002



Number 3
Use caution when working around chemicals. **Wear all protective equipment according to the label of the product.**
Part no. DCL-8006



Number 4
Read and understand the operator's manual before using or working around the equipment.
Part no. DCL-8000

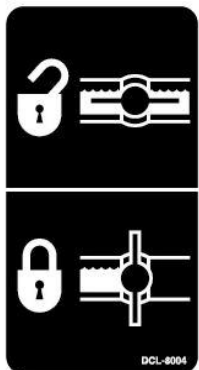

Number 5
Open (unlocked) and closed (locked) position of the ball valve.
Part no. DCL-8004

Safety Sign Locations



Preparing the Applicator for Operation

After the Applicator has been installed on the baler, please follow the steps below to prepare for operating the applicator both safely and correctly.

Filling the tank:

Read the label of the product you choose to fill the tank to determine individual protective measures you the operator should take. Locate the drain/fill line on the right side of the baler. Open the cam-couplers (A) and remove the protective plug (B). Insert the male coupler (found on transfer pump) into the female cam and close the cams (A). To open the ball valve (C) turn the handle so it is vertical. After the ball valve has been turned on switch the pump to the On position. Monitor the level on the tank visually and shut off the pump before over filling. Once the pump is turned off, close the ball valve and remove the male coupler. The handle of the ball valve (C) will be horizontal when closed. Reinstall the protective plug and close the cams. The Harvest Tec model 9212 and 9215 transfer pumps are recommended for this process.

Water is recommended for first time and annual start up procedures.

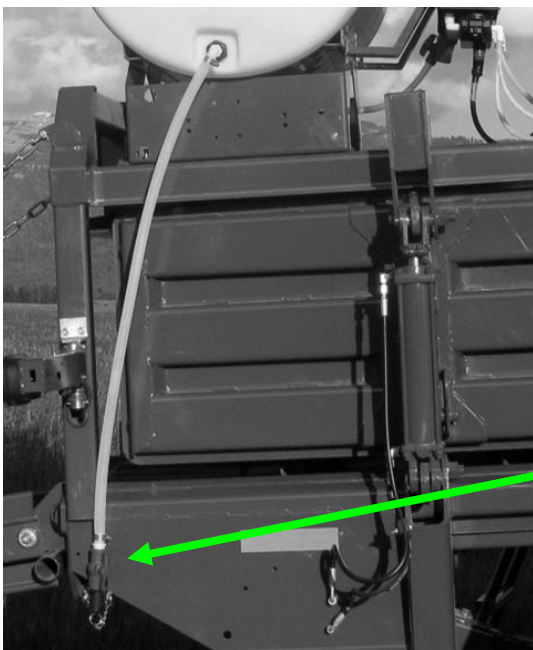

Drain/Fill line on right side of baler

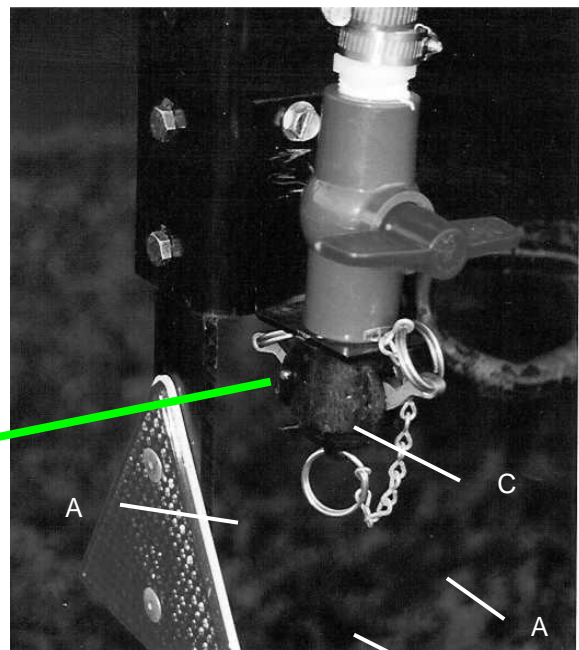

Enlarged view of the drain/fill line valve and cam-coupler assembly.

Connecting Power and Communication Harness

The harnesses are located at the front of the baler near the hitch and at the back of the tractor near the drawbar. See arrow below. Make sure all connection wires are free between the hitch of the baler and the back of the tractor, especially when tractor is turning away.

WARNING: Stop tractor engine and shift to park or neutral, set brakes and remove key before leaving the tractor.



Operation of the Main Ball Valve

The ball valve shall be closed at all times when the applicator is not being used. The valve shall also be closed when any service work is being done to the baler or applicator.

The ball valve is located on the left side of the baler, connected to the pumping manifold. See arrow below.

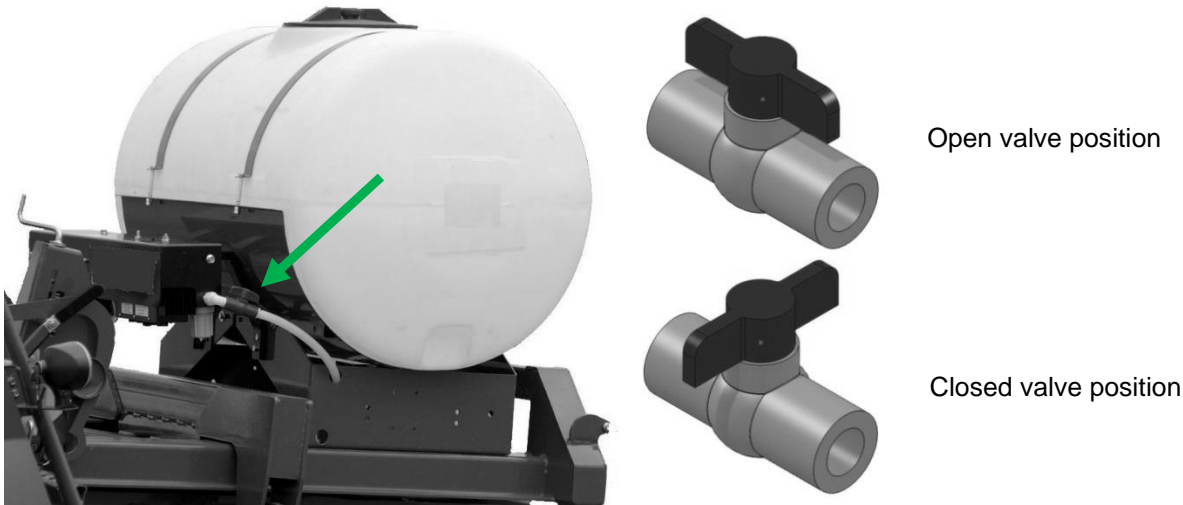

Krone ISOBUS Integration (optional)

*Refer to the Installation Manual for details on connecting the system to the ISOBUS.

Harvest Tec applicators will now be able to display on a split-screen ISO terminal, the CCI1200, offered with Krone balers. The moisture can also be shown on the baler's operating screen but the split-screen setup is the recommended option from Harvest Tec for the monitoring of all critical system functions such as moisture, application and bale information.

All 2018 (and beyond) Krone balers (starting with SN 976909) will be capable of running through the ISOBUS. If unsure, balers with a software version structured similar to the screen shot below will be capable (right):

After the integration harness is hooked up, you should see a status bar as the ISO display loads the Harvest Tec display information. After loading, the Harvest Tec system Main Menu will be visible on the terminal. (as pictured below)

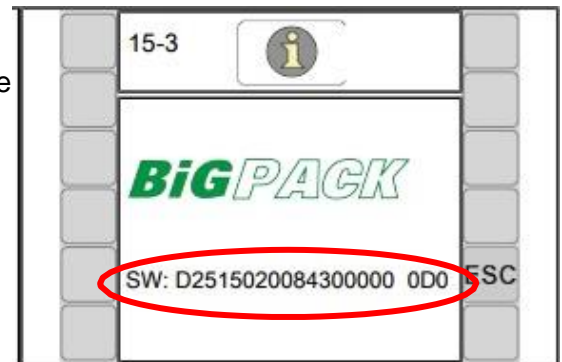

For information on how to configure the CCI1200, please reference the manufacturer's operation manual.

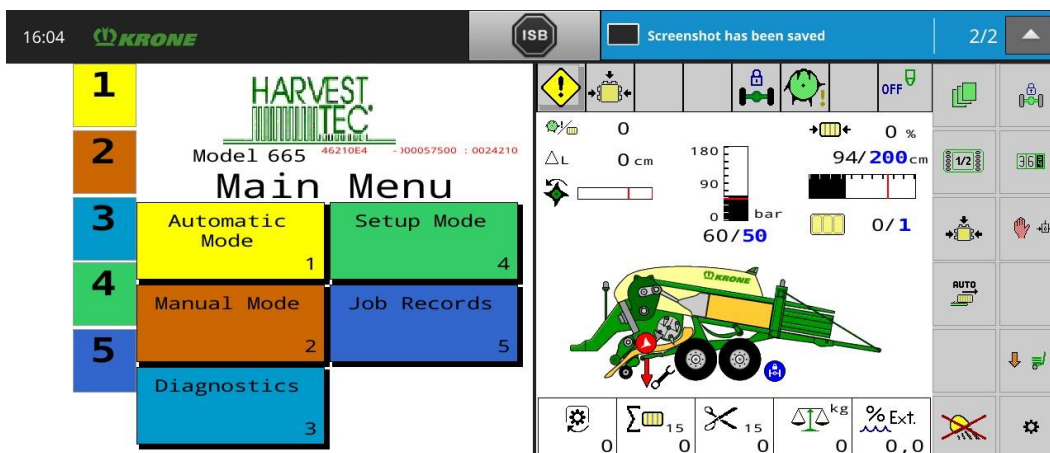

Bluetooth Operation

Turn On / Off iPad using the Sleep/Wake button

*(Info from Apple User's Guide)

Turn iPad on. Hold down the Sleep/Wake button until Apple logo appears. iPad will take a moment to load.

You can lock iPad and put it to sleep when you're not using it. Locking iPad puts the display to sleep, saves the battery, and prevents anything from happening if you touch the screen.

Sleep/Wake Button



When you are not going to use the iPad for an extended period of time put the unit into sleep mode by pressing the Sleep/Wake button. Press Sleep/Wake button to wake iPad and then unlock iPad by entering passcode.

Turn iPad off. Hold down the Sleep/Wake button for a few seconds until the slider appears onscreen, then drag the slider to the right.

Downloading Harvest Tec App

1. If iPad does not have Wi-Fi turned on, select the Settings tab  then select the Wi-Fi tab (below).

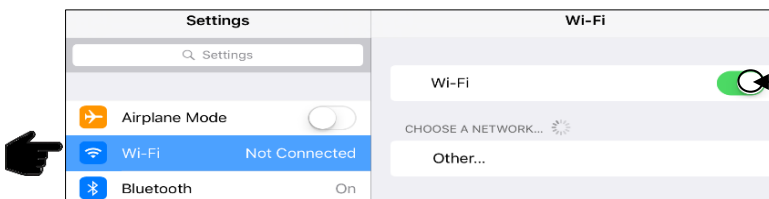

2. Turn Wi-Fi on by sliding button to the right.
*Green bar indicates ON

3. Use same process to turn on Bluetooth function

4. Select an available network when detected by the iPad, shown in area above that currently says 'Other.'
5. Select App Store icon (below) and open. *You will need a Wi-Fi connection available to view App Store.



****The Harvest Tec system WILL NOT appear under the Bluetooth tab in the Setting App. Open the Hay App to connect.**

Download the Hay App in the App Store by searching for 'Hay App' in the search bar in the top right corner of screen (right):
*The advertisements displayed on the App Store screen will change.

The app will have the icon as shown:

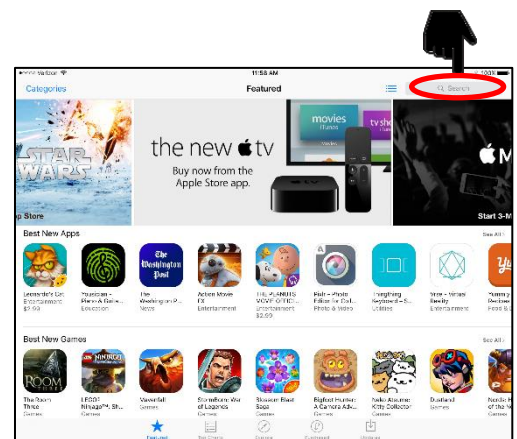

Note: Operation requires iPad Mini or iPad 3rd Generation (2012) or newer, running the current iOS operating system or one version previous required for iPad option.

Shutting Down the Hay App

To shut down the Hay App double click the home button (Figure A). This will show the open apps that are running on your iPad (Figure B).

*Note: By pressing the home button one time to return to the home screen, the Hay App **does not** shut down. The system will however, stop applying preservative after 10 seconds.



Figure A

Slide the app you want to shut down by sliding the app toward the top of the iPad, until the app is no longer visible (Figure C).

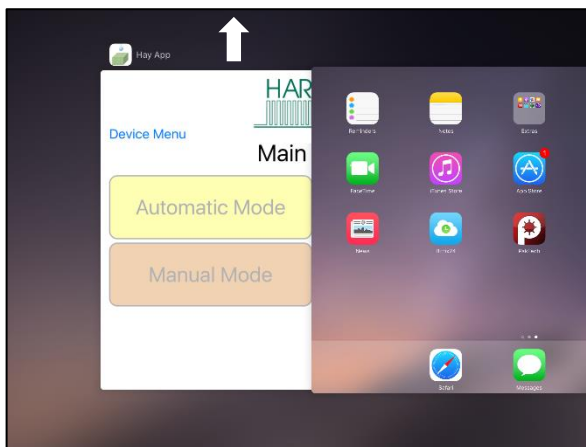

Figure B

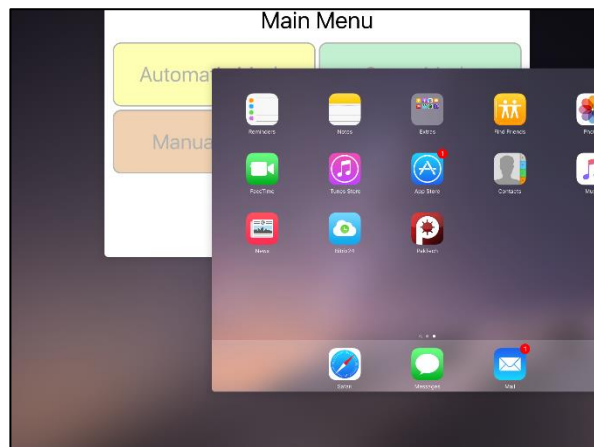

Figure C

Bluetooth Receiver

*New for production year 2018. All Bluetooth receivers (030-6672B) are now equipped with lights to indicated both power and iPad connection.

Blinking Lights – System is waiting for the processor to connect, which could take up to 35 seconds.

Red Light – The Bluetooth receiver has power

Green Light – When the proper active connection is selected in the Hay App menu, the green light will indicate connection with the iPad.



Operating the Harvest Tec iPad App (continued)

When ready to operate your applicator system, open the Hay App on the iPad by selecting the Hay App icon.

**Use the following information for Large Square Balers.*

Device Selection

The app will open to the Device Menu screen as shown below. Applicators which are equipped with the Bluetooth receiver that are within range (20') of the iPad and have power going to them, will be shown under the Active Connections section.

After the iPad connects to the Bluetooth receiver, select the applicator you want to connect with.

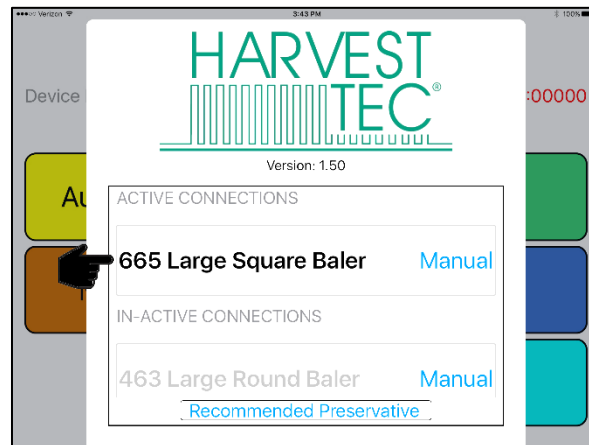

The In-Active Connections section will show applicator systems that have been connected in the past, but are not within range of the iPad or do not currently have power going to them (bottom left).

To remove a baler from the In-Active list, slide the bar displaying the baler name to the left, and select the Delete button that will appear (bottom right).

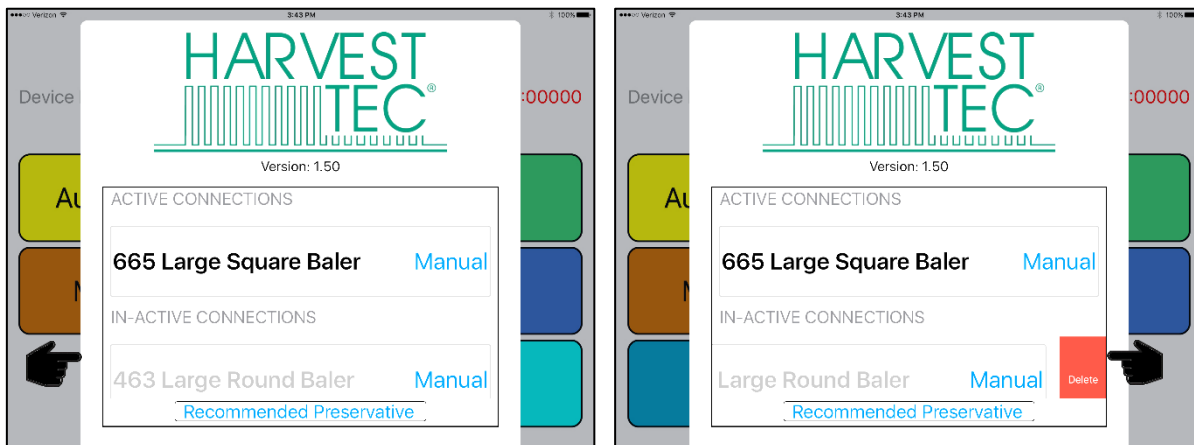

Operating the Harvest Tec iPad App (continued)

Manual Selection

Selecting the Manual button (below) displayed to the right of the baler name will open the operation manual for your baler.

*Use the following information for Large Square Balers.

*You do not need to be connected to a baler to open the manual after a baler has been connected.

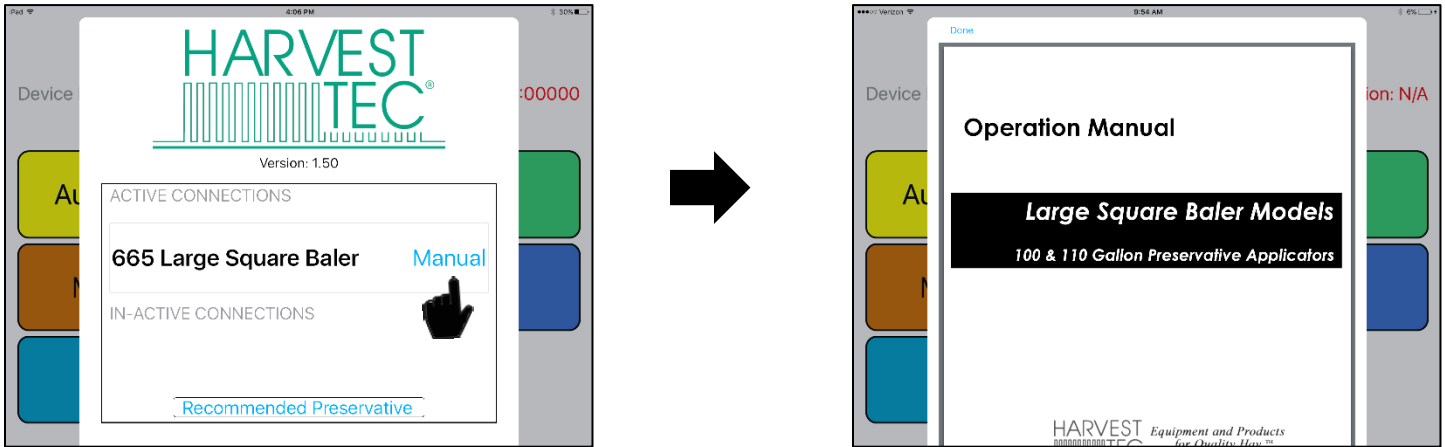

When finished reviewing the manual, press the Done button in the top left corner to return to the Device Menu.

Recommended Preservative

To view recommended preservative information, application rates, and frequently asked preservative questions, select Recommended Preservative (below).

*You do not need to be connected to a baler to open the recommended preservative page.

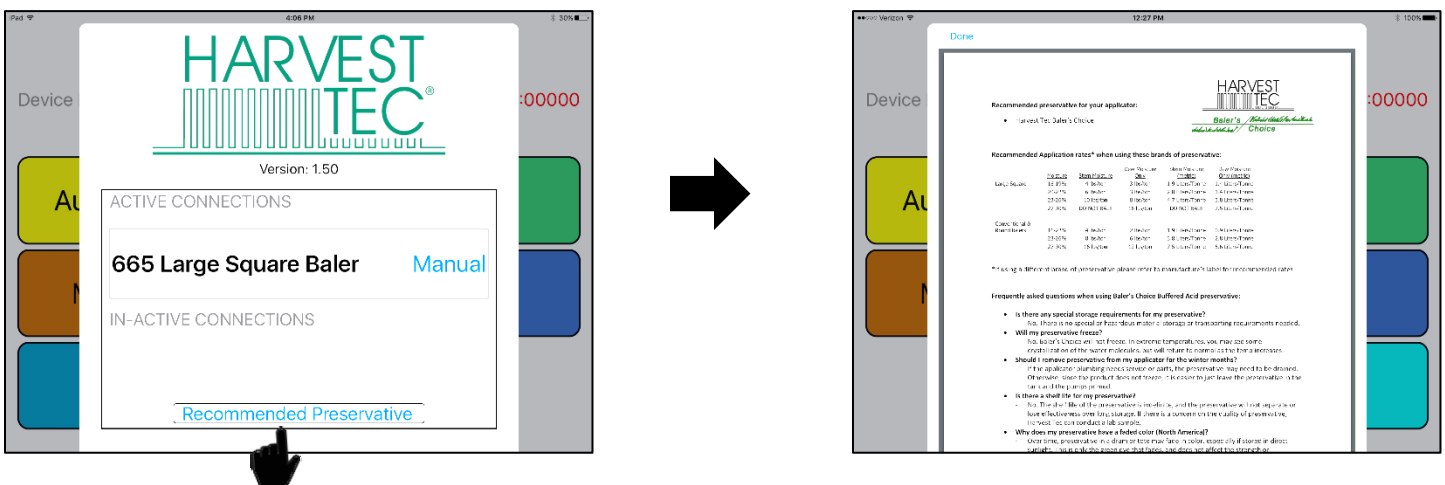

Operating the Harvest Tec iPad App (continued)

Once you have selected the baler you want to connect with from the Device Menu, the applicator main menu will display (below).

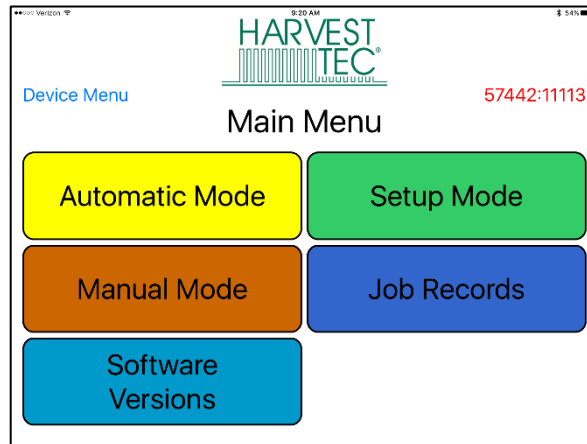

Tab Descriptions

Automatic Mode: This mode allows you to use all of the applicator features such as adjusting preservative application on the go and counting total pounds of product used.

Manual Mode: Allows operator to manually turn pumps on and off. This mode also has moisture content displayed. Use this mode to prime pumps.

Software Versions: Selecting this tab will display the software currently installed.

Setup Mode: This mode allows the operator to adjust bale rate, application rate settings and select tip output.

Job Records: Keep track of up to 300 jobs with total product used, average moisture content, tons baled, and baling date.

Screen Menus

Use the screen shots below to navigate through the operation screens.

Automatic Mode

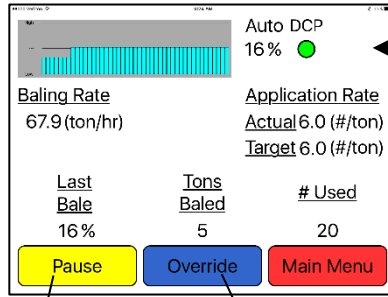
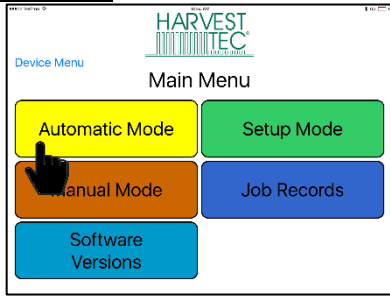

Bluetooth Connection Indicator
 Green -DCP is connected
 Yellow -DCP connecting
 Red -DCP not connected

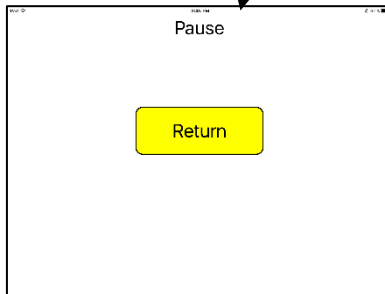

Manual Mode

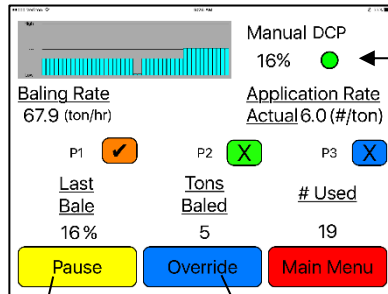
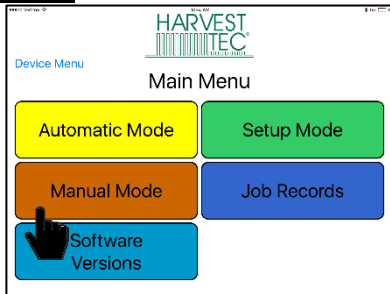

Bluetooth Connection Indicator
 Green -DCP is connected
 Yellow -DCP connecting
 Red -DCP not connected
 X -Pump is OFF
 ✓ -Pump is ON

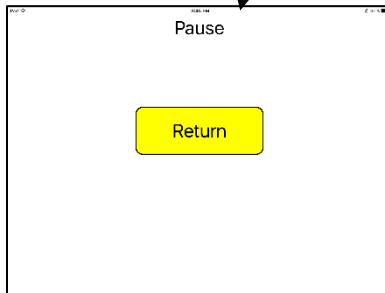

Operation Note:

Pressing the Home Button on the iPad **WILL NOT** immediately stop application of the System (see below):

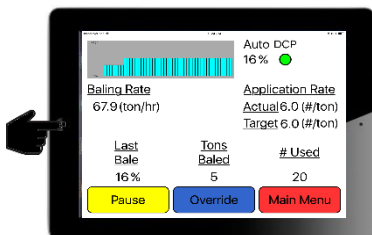

Select **Pause** or **Main Menu** to stop application

*To close app see the Shutting Down Hay App Section

**When the app is not displayed for 10 seconds, preservative application will stop.

Setup Mode – Large Square Balers

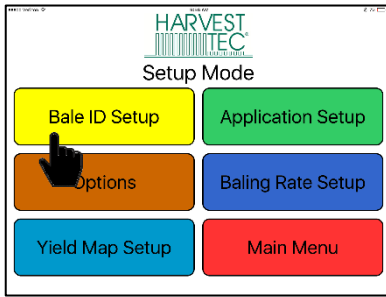
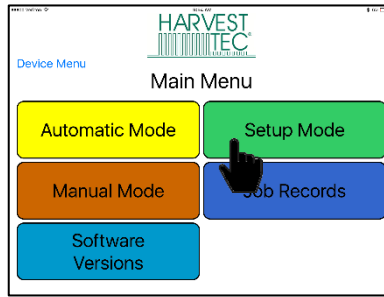

*Only used if equipped with Tagger

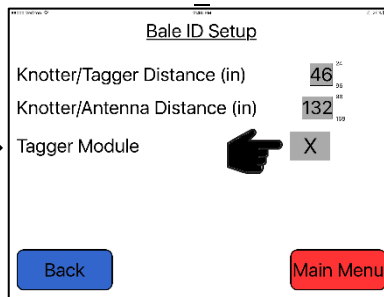

Turn Tagger ON by selecting the X

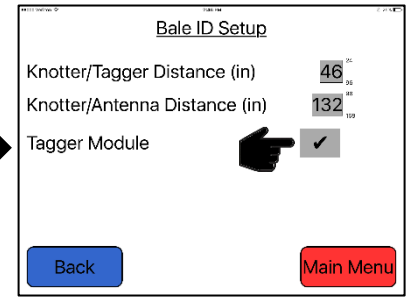

✓ Indicates tagger is ON

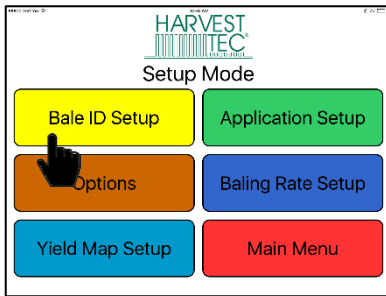

*If RFV Equipped, additional options will appear on Bale ID Screen (next)

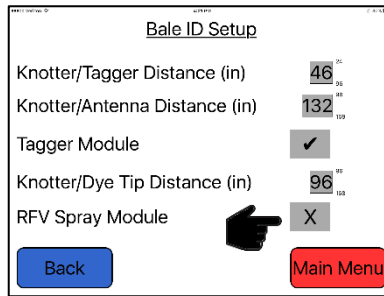

If using RFV Spray Module, turn ON by selecting the X

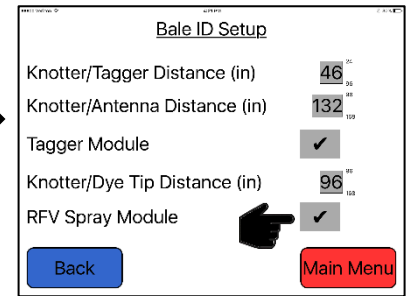

✓ Indicates Spray Module is ON

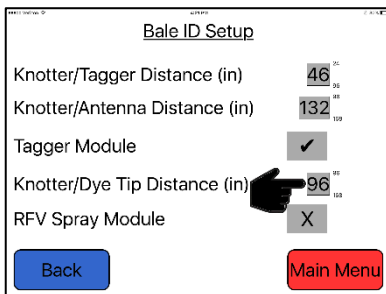

Make sure Knotter/Dye Tip Distance is correct

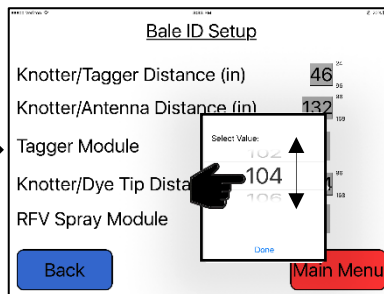

Select correct distance

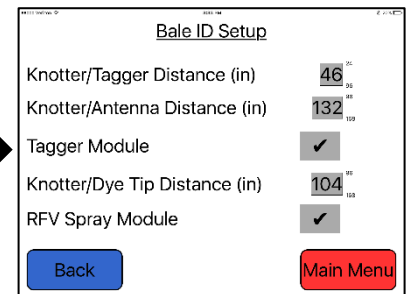

Setup Mode – Large Square Baler (continued)

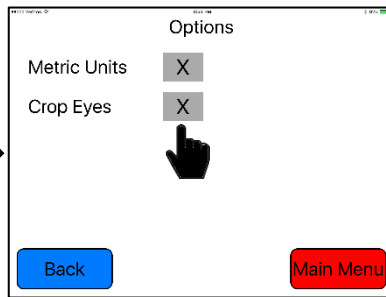
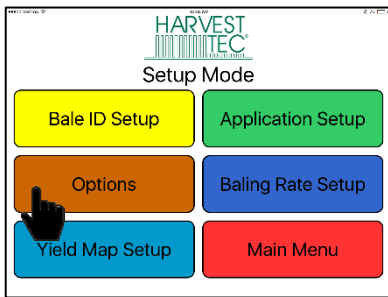

*Select X to turn on options shown

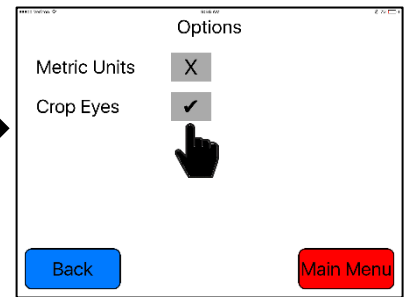

✓ Indicates Crop Eyes are ON

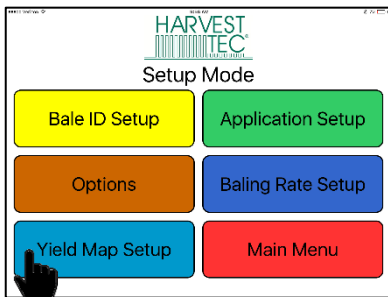

*Only used if equipped with GPS

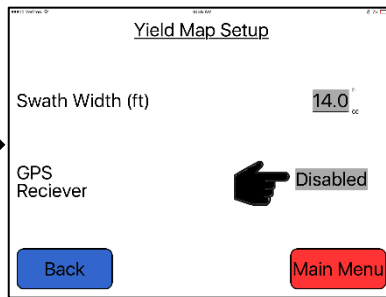

*Select grey area to change

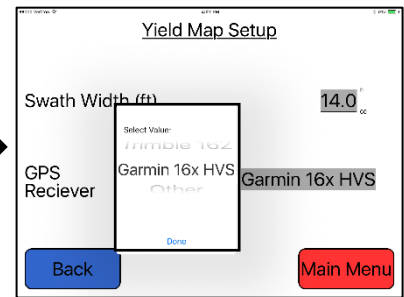

*Select appropriate GPS unit

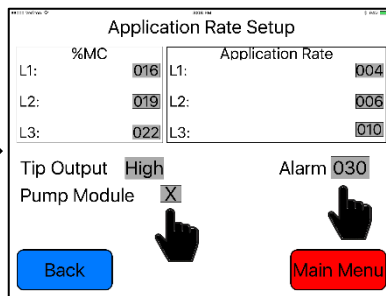
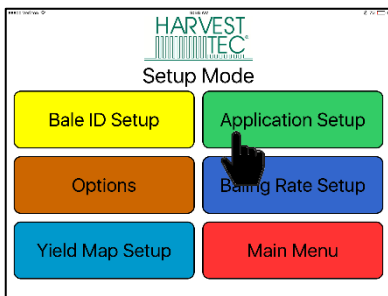

*Adjust alarm setting and turn on pump module by selecting X in grey area

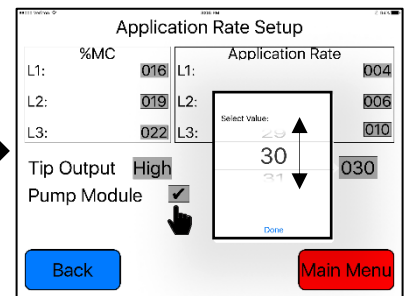

✓ indicates Pump Module is on

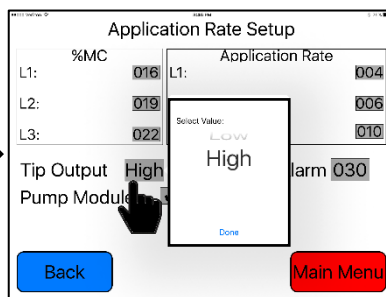
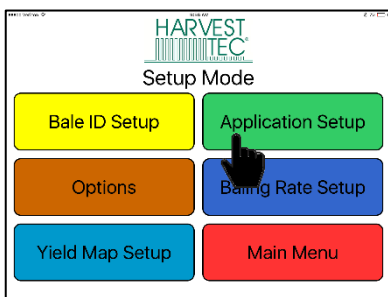

Select correct tip setting
*High tips are installed from factory

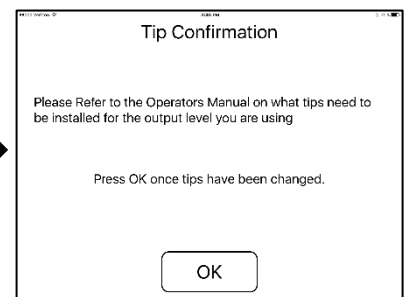

Press OK if correct tip output has been selected

Setup Mode – Large Square Baler (continued)

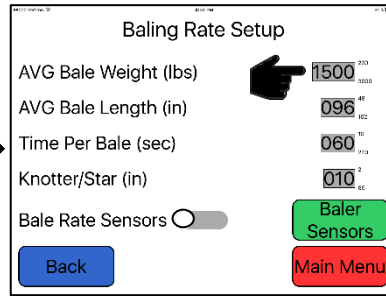
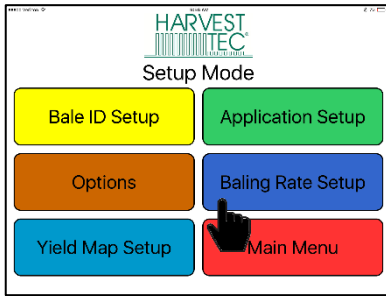

*Select correct bale weight, length, and time per bale information

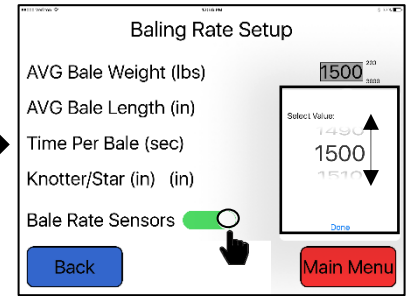

*Turn on Bale Rate sensor, Green bar indicates sensors are ON

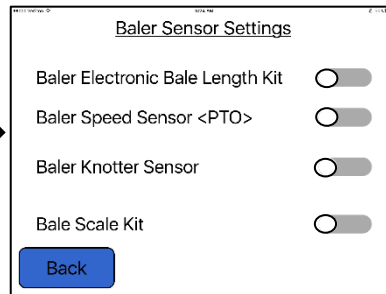
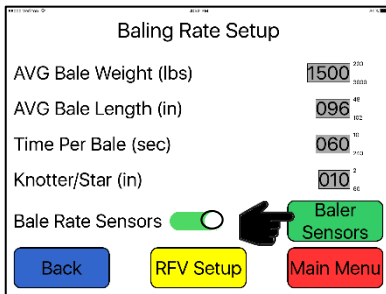

*Ensure all baler sensors are turned OFF

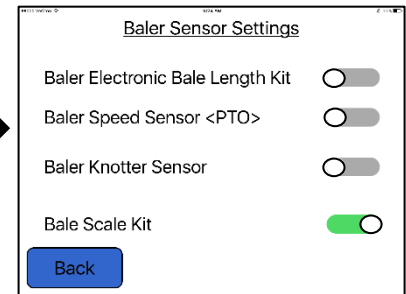

*If using a scale kit, turn sensor ON

Setup Mode – Large Square Baler (If RFV Equipped)

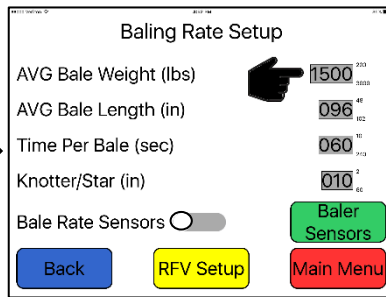
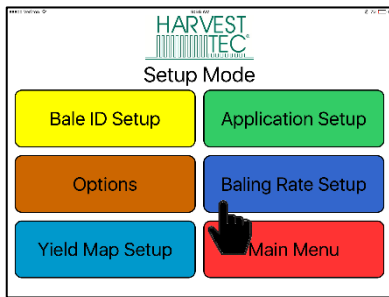

*Select correct bale weight, length, and time per bale information

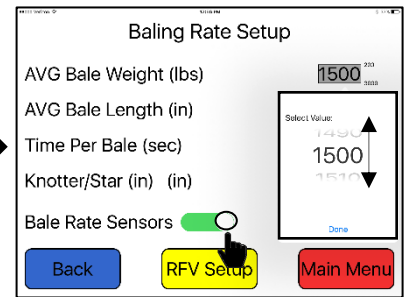

*Turn on Bale Rate sensor, Green bar indicates sensors are ON

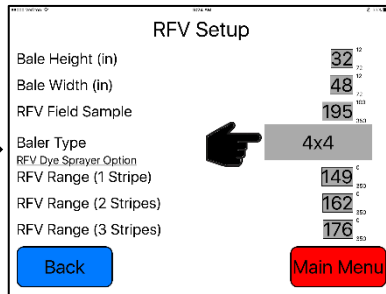
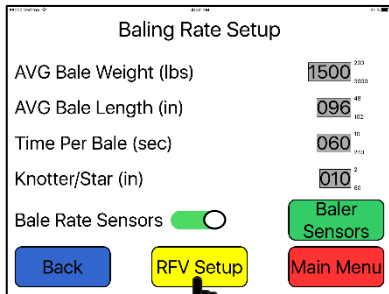

*Select correct bale size

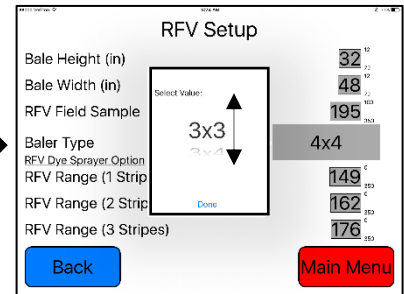

Software Versions

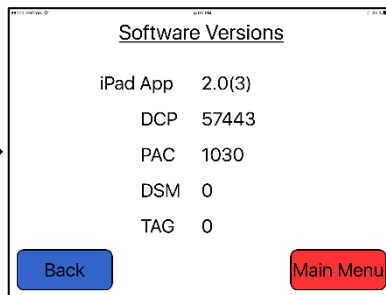
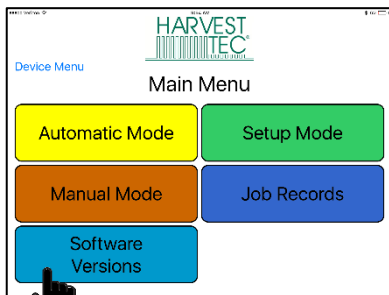

*Versions shown are examples (will not match your applicator)

Job Records

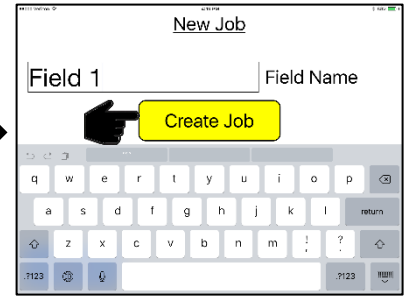
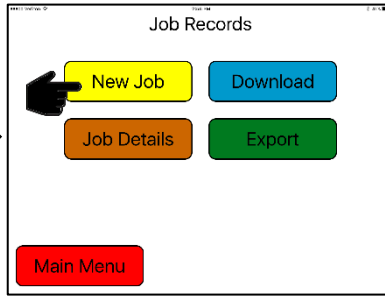
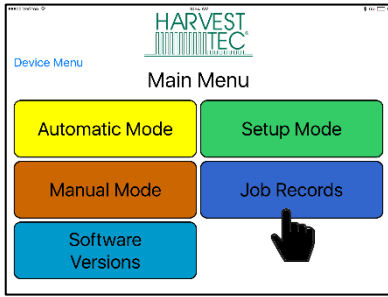

Type desired Field Name, select Create Job

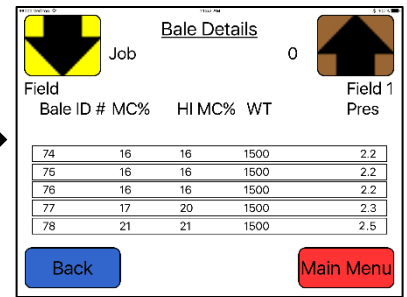
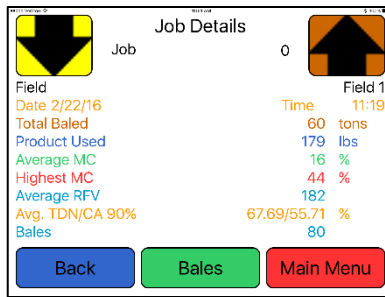
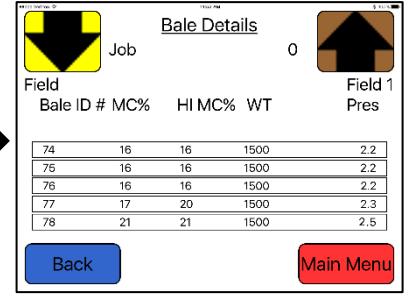
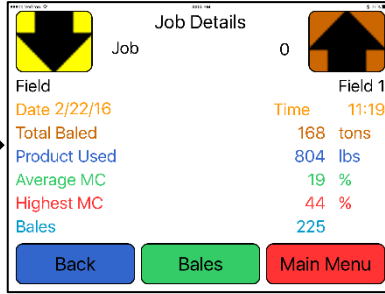
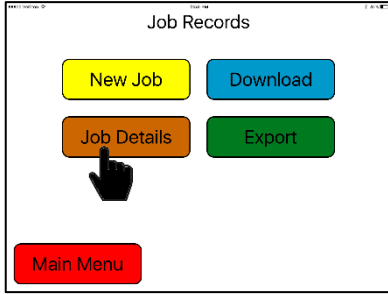

*When RFV Equipped, Average RFV, Ave TDN/CA90% info will be added

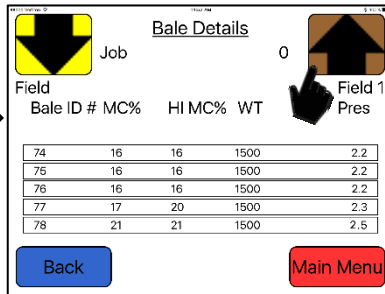
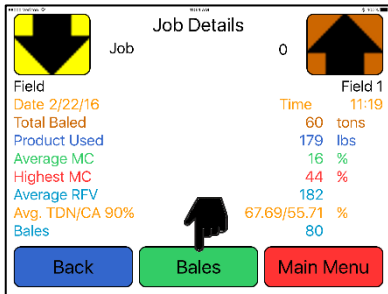

For Bale details select Bale Button

Use arrows to change jobs shown

Job Records (continued)

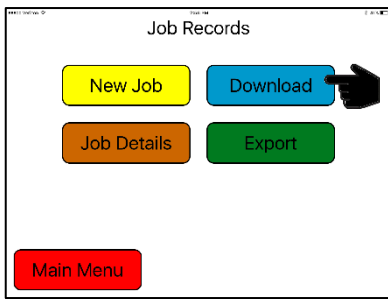

Select Download when wanting to download job records to USB Stick

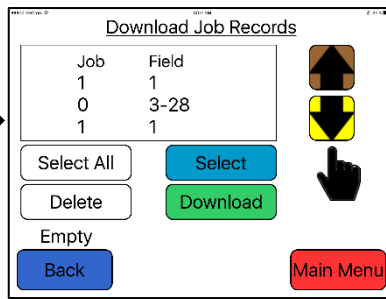

Use arrows to change jobs shown.
 ↕ Indicates selected jobs

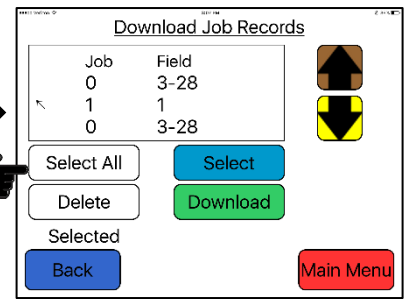

Pressing the Select or Select All tab to choose which job to download or delete

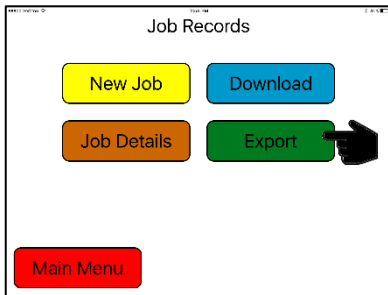

The Export allows you to send an email a file with selected job records

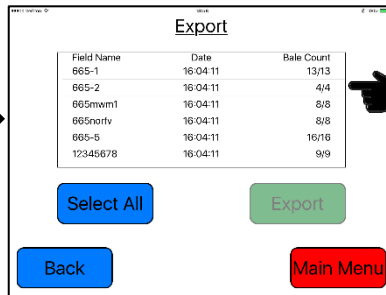

When the Export page is opened the bale information in each job will be retrieved.

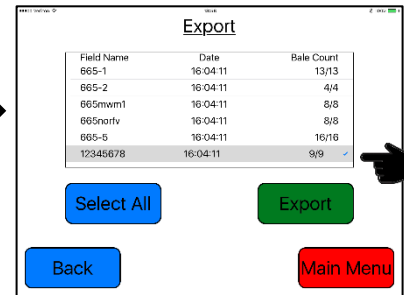

When all bales have been retrieved, Export tab will activate, select a job(s) to export



If choosing one job to email, select the Mail tab. Multiple jobs can be selected

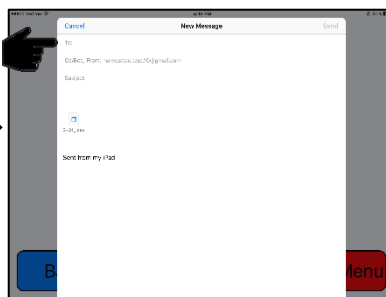

Email will appear w/file attached, enter address
 *If two or more jobs selected, email will appear

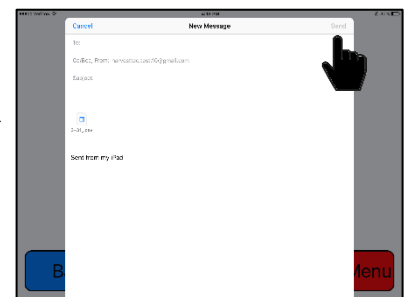

Press the Send button in top right corner, (your iPad notification sound will play)



If choosing to view job on iPad, recommended to download Excel app to view job records information

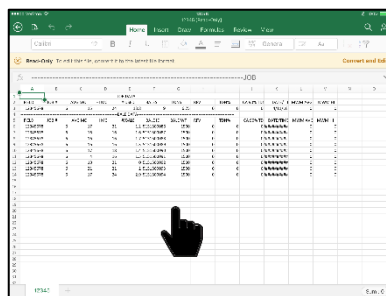

After Excel app is selected, the job record spreadsheet will open
 *iPad can only view 1 job at a time.

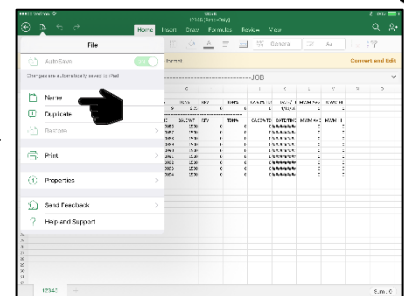

To save the job, select Name from the drop down tab

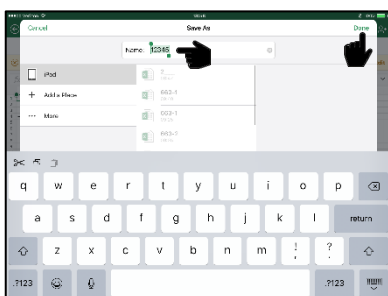

Enter desired name in center of page and press Save on the top right corner

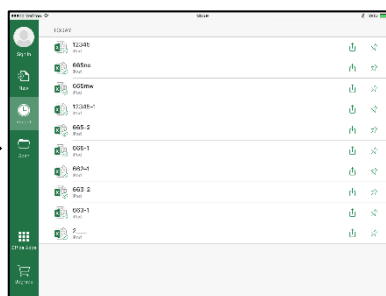

After selecting Save, the list of saved files in Excel will appear. Select any job to view

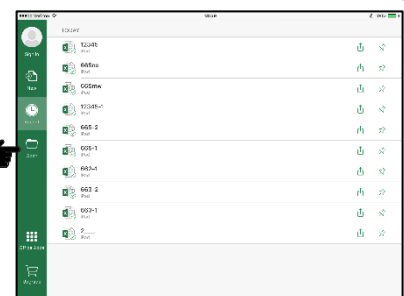

You also can view the jobs saved by selecting Open tab after opening the Excel app

First Time and Annual Startup Instructions – Large Square Balers

THE UNIT MUST BE CHECKED OUT BEFORE FIELD OPERATION!

Check and Prime the Pumps

1. Put 10 gal (5L) of water in tank and turn main ball valve on.
2. Inspect for any leaks or drips at this time. If any are found tighten or replace area or fitting.
3. Press the SETUP MODE key. Turn bale rate sensors off (Figure 1). Make sure the AVG Bale Weight is 1500 lbs (680kg) and the AVG Baler Length is 96" (243cm), Time per bale is 60 seconds, and press the MAIN MENU key to return to the opening screen.
4. Press the MANUAL MODE key and the screen will appear.

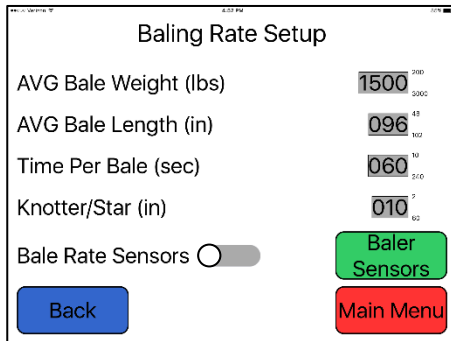

Figure 1

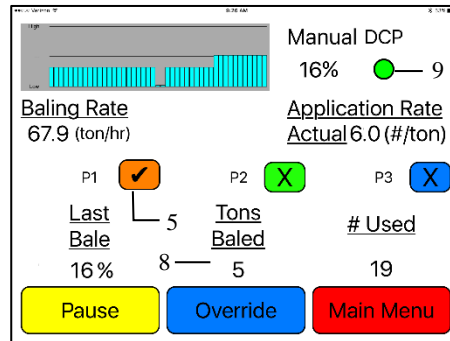

Figure 2

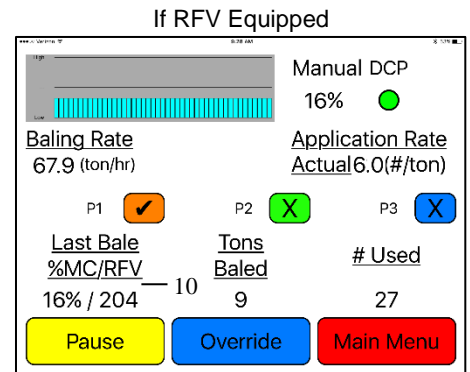

Figure 3

Note: The system comes with the tips already installed on the spray shield or nozzle tubes.

Pump	Low Output (Lbs / Ton) (L/MT)	High Output (Lbs / Ton) (L/MT)
1	1.1 – 1.5 (.5 - .7L)	1.9 – 2.6 (.9 - 1.2L)
2	1.9 – 2.6 (.9 - 1.2L)	2.9 – 3.9 (1.3 - 1.8L)
3	2.9 – 3.9 (1.3 - 1.8L)	5.7 – 7.7 (2.6 - 3.5L)

5. Turn pump 1 on (P1). To turn the pump on, select the colored box next to P1 and change the 'X' to a check mark. Repeat the process for pumps 2 and 3 (P2 and P3).
6. This process will also be used to prime the pumps whenever needed.
7. While running pumps check for a good spray pattern out of the respective tips and verify that no parts of the system are leaking.
8. While doing these tests the Volume Used on the bottom of the screen will be increasing, this verifies that the flow meter is functioning.
9. The DCP button displays your connection signal with the Bluetooth receiver. Green – DCP is connected, Yellow – DCP is connecting, Red – DCP not connected. Pressing MAIN MENU key to return to the initial startup screen.
10. If your applicator is RFV equipped (figure 3), the RFV value of the last bale will be displayed next to the last bale moisture reading.

Setting Up the System for initial use with the iPad

In this mode you will setup your initial application rate and baling rate.

**Use the following information for Large Square Balers.*

Application Rate

After pushing the SETUP MODE key in the Main Menu screen, the top left screen will appear:

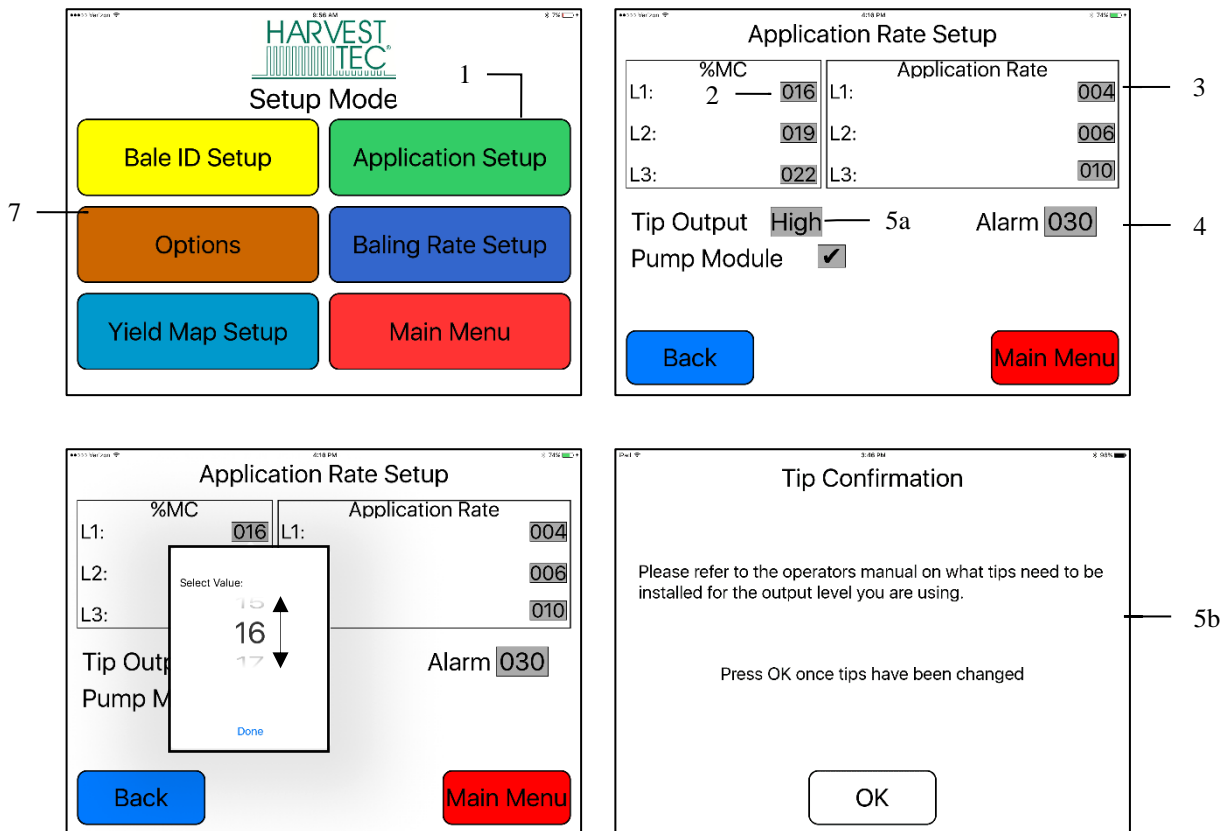

1. On the Setup Mode screen press the APPLICATION RATE key. Once selected the SETUP APPLICATION RATE screen will be shown. (Top right picture)
2. Press any of the grey number values to the right of %MC to adjust their figures. The scroll pad shown on the bottom left will display. Remember level 1 must be lower than level 2 and level 2 must be lower than level 3. Press Done, when value has been selected. Harvest Tec products recommend set points of 16, 19, and 22 % MC levels. These are preset from the factory.
3. To change rate of chemical application, press any of the grey number values to the right of RATE. Remember level 1 must be lower than level 2 and level 2 must be lower than level 3. Press Done, when value has been selected. Harvest Tec products recommend rates of 4, 6, and 10 lbs/ton (2,3,5 L/MT). These rates are preset from the factory. Press Back to return to previous screen. **IT IS THE OPERATORS RESPONSIBILITY TO FOLLOW THE RECOMMENDATIONS OF THE PRESERVATIVE. ONLY THE OPERATOR CAN APPLY THE PROPER RATE.**
4. To set the alarm, press the grey number value and set the level at which you want the alarm to activate. To turn the alarm off, set level above 50.
5. Press the grey area next to Tip Output to **cycle between the high and low sets of tips (5a)**. Use the correct tip set for the field conditions. The tip confirmation screen will appear (5b). Press OK once tips are changed.
6. Next press the BACK key found on the bottom left hand figure of the screen to return to SETUP MODE screen or press MAIN MENU key on bottom right hand figure of the screen to return to opening screen.
7. Press OPTIONS to adjust the unit between metric and standard units.

Baling Rate Settings – Large Square Balers

After pushing the SETUP MODE key in the Main Menu screen, the screen on the left will appear:

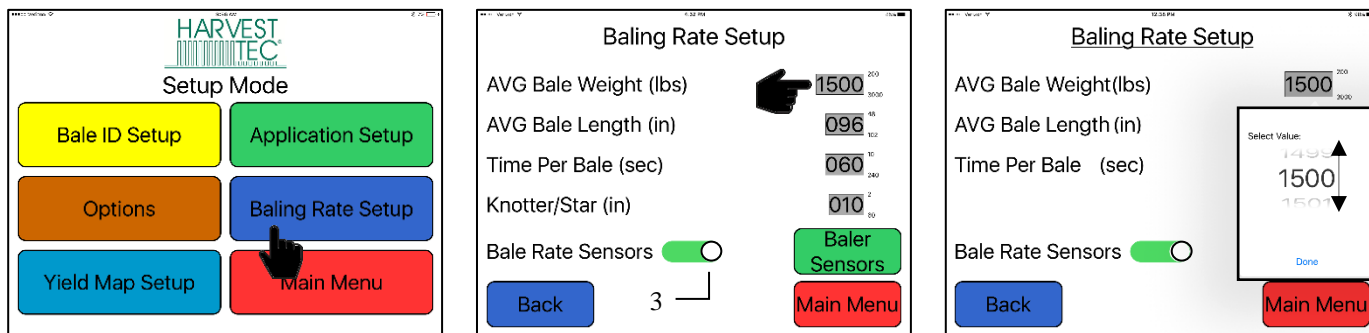

1. On the setup mode screen press the BALING RATE key.
2. Press the grey number value to the right of AVG Bale Weight (Lbs). To adjust the weight of your bales, the scroll tool shown on the right will display. Scroll through the values to select correct information, press DONE when value has been selected. The information will be saved until updated. Use the same procedure for adjusting bale length and time per bale.
3. Large square balers are equipped with Bale Rate Sensors which can be turned ON by sliding the bar to the right as shown above. A green bar indicates that the bale rate sensors are on. While a grey bar means the bale rate sensors are off.
Note: Bale rate sensors are used instead of a fixed time per bale to help determine a ton per hour reading.
4. Press the BACK key found on the bottom left hand figure of the screen to return to SETUP MODE screen or press the MAIN MENU key to return to the opening screen.

Baling Rate Settings – Baler Sensors

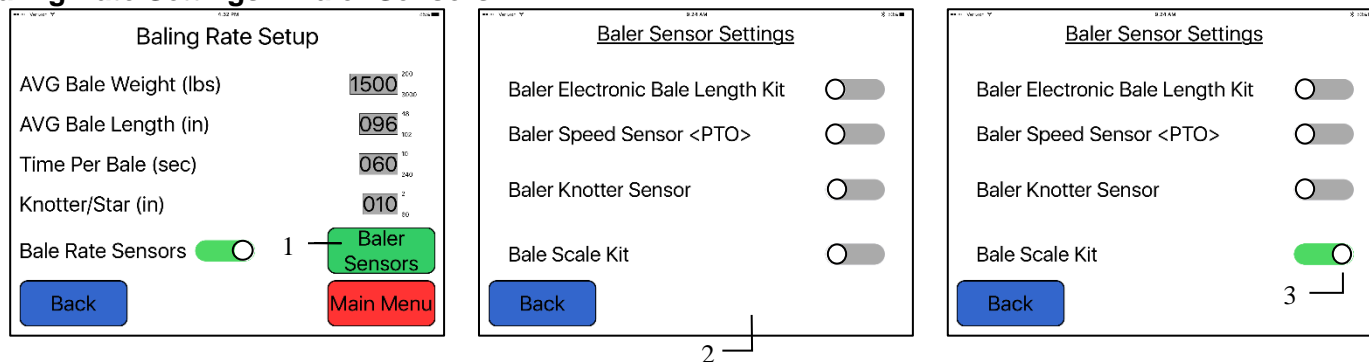

1. On the Baling Rate Setup screen select the Baler Sensors Tab.
2. Ensure all baler sensors are turned off on the Baler Sensor Settings Tab.
3. If using a Bale Scale Kit, turn on that sensor by sliding the tab to the right. A green bar indicates the sensor is turned on.

RFV Setup

Use the information below when your applicator is RFV Equipped. *Only available on large square balers.

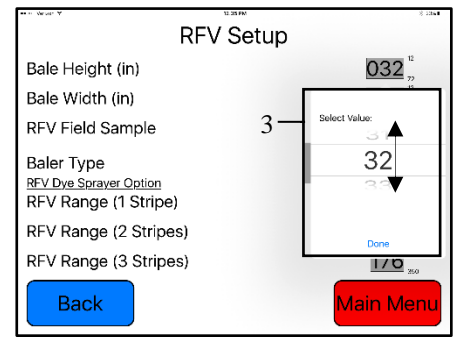
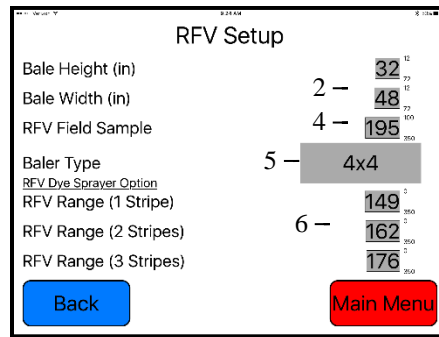
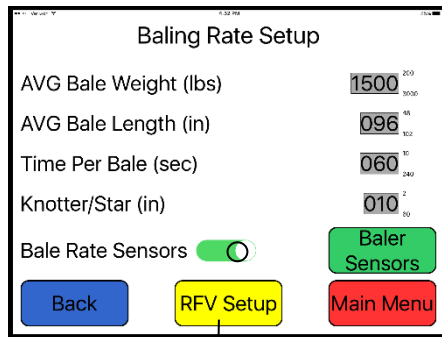

1. Select the RFV Setup tab on the Baling Rate Setup Screen.
2. Select the correct height and width of bale by selecting the grey area. All values can be changed.
3. After selecting a value to change, a menu will appear to scroll through and select the correct value and press done to save the information.
4. Select the RFV Field Sample value and input the correct value. *This is the RFV value that has been tested by a lab, which is needed to properly measure the RFV value when baling.
5. Choose the correct baler type: 3x4, 3x4, 4x4, or 3x4 Krone HDP
6. Select your desired RFV ranges from each tip to show either 1 stripe, 2 stripes, or 3 stripes. The preset values from the factory will be set at 150, 170, and 190.

***If you are baling hay with an RFV value below the selected 1 stripe value, the system will not spray the bale.**

Operation Instructions

Automatic mode will automatically apply product based on hay moisture content sensed by the moisture sensors and the operator's presets. See SETTING UP SYSTEM FOR INITIAL USE to change any of these settings. Manual mode will apply preservative to the hay at a fixed rate regardless of the moisture content.

*Use the following information Large Square Balers.

Automatic Mode

After pushing the AUTOMATIC MODE key in the Main Menu screen, the following screen will appear:

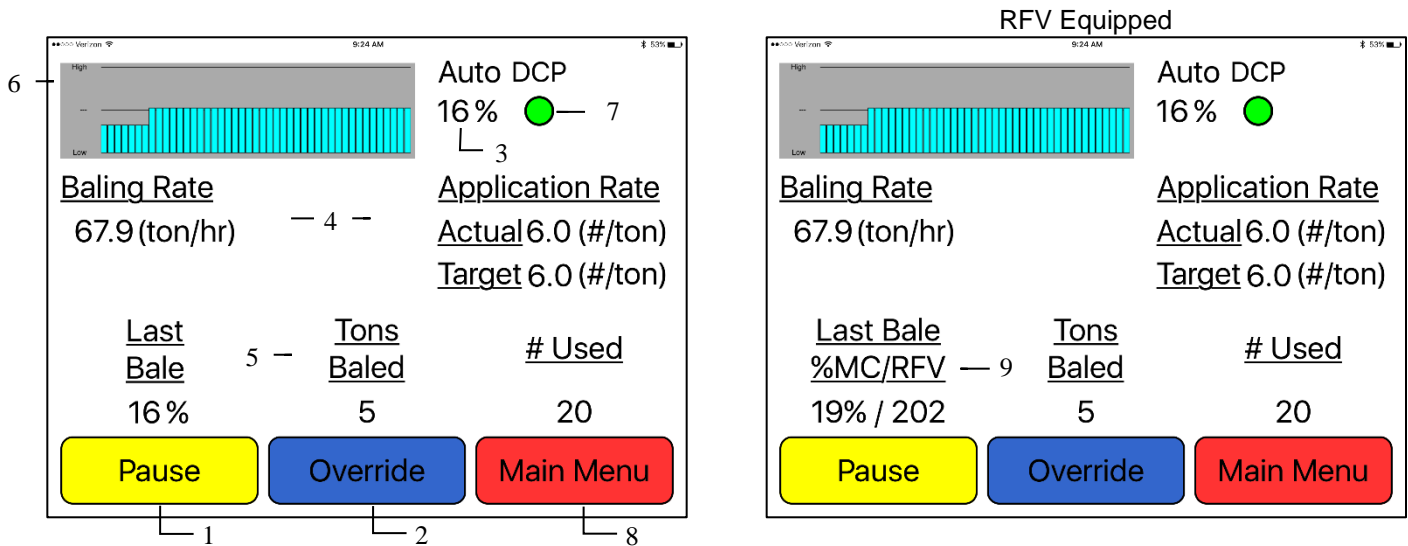

1. To pause the unit while in operation select the Pause key.
2. Push the OVERRIDE key to turn on all three pumps at the same time for full output of the system. Use this mode when going through a short area of wet crop.
3. The moisture content is shown in the upper right hand corner.
4. Baling Rate and Application Rate are shown in the middle of the screen. The operator sets the target application rate and baling rate in the setup mode; the actual rate should be within +/- one pound.
5. Volume used shown at the bottom of the screen will show accumulated pounds of preservative used on the go. This number will reset at power down, but remains in the job record screen. **NOTE: Initial start-up requires pressing the New Job key in the Job Records screen in order for Volume Used accumulation to be recorded. This only needs to be done once on initial start-up of system and not every time the system is started for operation.** (See JOB RECORDS screen)
6. The graph shows the moisture trend from the past 90 seconds in 3 second intervals.
7. The DCP button shown when using an iPad displays your connection signal with the Bluetooth receiver. Green – DCP is connected, Yellow – DCP is connecting, Red – DCP not connected.
8. Press the MAIN MENU key to return to the opening screen.
9. When your applicator is RFV Equipped, the RFV value will be displayed next to the Last Bale moisture reading in the bottom left corner of the screen.

Manual Mode

After pushing the MANUAL MODE key in the Main Menu screen, the following screen will appear:

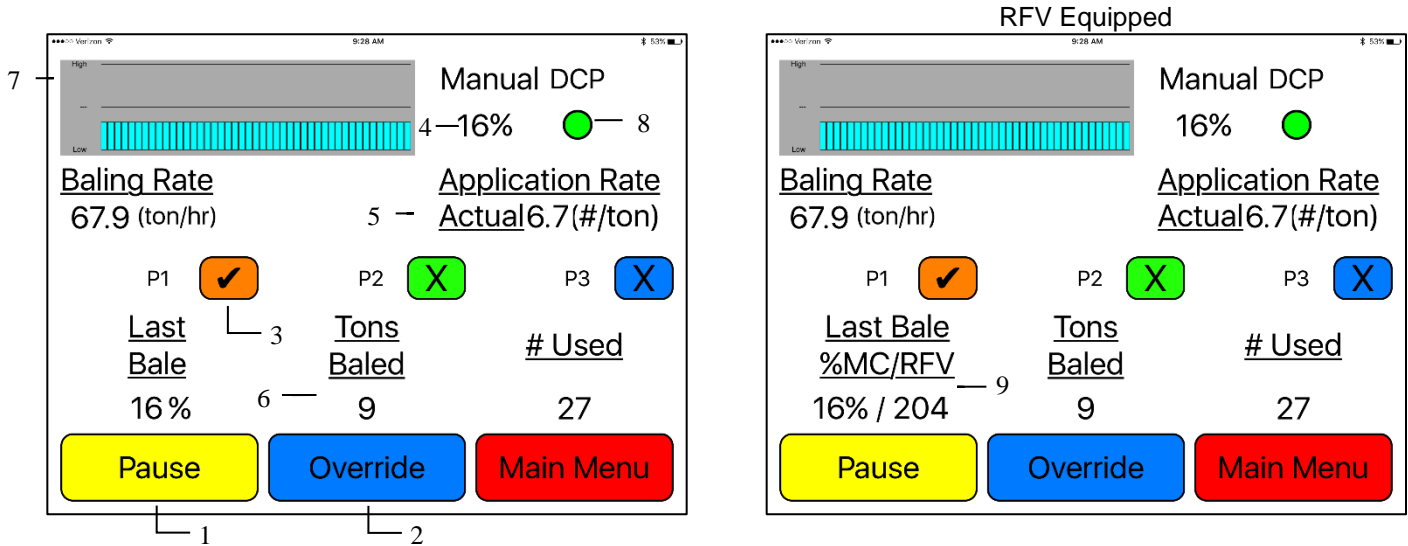

1. To pause the unit during operation select the Pause key.
2. Push the OVERRIDE key to turn on all three pumps at the same time for full output of the system. Use this mode when going through a short area of wet crop.
3. To turn the pump on, select the colored box next to P1 and change the 'X' to a check mark. In Manual Mode (regardless of moisture, baling rate or bale weight) the outputs are fixed rates as follows:

Large Square Balers

Pump	Low Tips Output (Lbs / HR) (L)	High Tips Output (Lbs / HR) (L)
1	60 (27L)	100 (45L)
2	100 (45L)	150 (68L)
3	150 (68L)	300 (136L)

4. The moisture content is shown in the upper right hand corner.
5. Baling rate and Application rate are shown in the middle of the screen. The output of a pump can be checked by dividing the preset output by the displayed baling rate. For example, if you have the high output tips in a large square baler and are running pump 1, by itself, your output is 100 lbs/hr. Given the baling rate shown on the above screen of 67.9 tons/hr, the application rate should be about 6.7 lbs/ton (100 lbs/hr divided by 6.7 tons/hr). The baling rate is set in the SETUP MODE.
6. Volume used shown at the bottom of the screen will show accumulated pounds of preservative used on the go. This number will reset at power down, but remains in the job record screen. **NOTE: Initial start-up requires pressing the New Job key in the Job Records screen in order for Volume Used accumulation to be recorded. This only needs to be done once on initial start-up.**
7. This graph shows the moisture trend from the last 90 seconds of baling (one reading every 3 seconds).
8. The DCP button shown displays your connection signal with the Bluetooth receiver.
Green – DCP is connected, Yellow – DCP is connecting, Red – DCP not connected.
9. When your applicator is RFV Equipped, the RFV value will be displayed next to the Last Bale moisture reading in the bottom left corner of the screen.

Job Records

After pushing the JOB RECORDS key in the Main Menu screen, the following screen will appear:

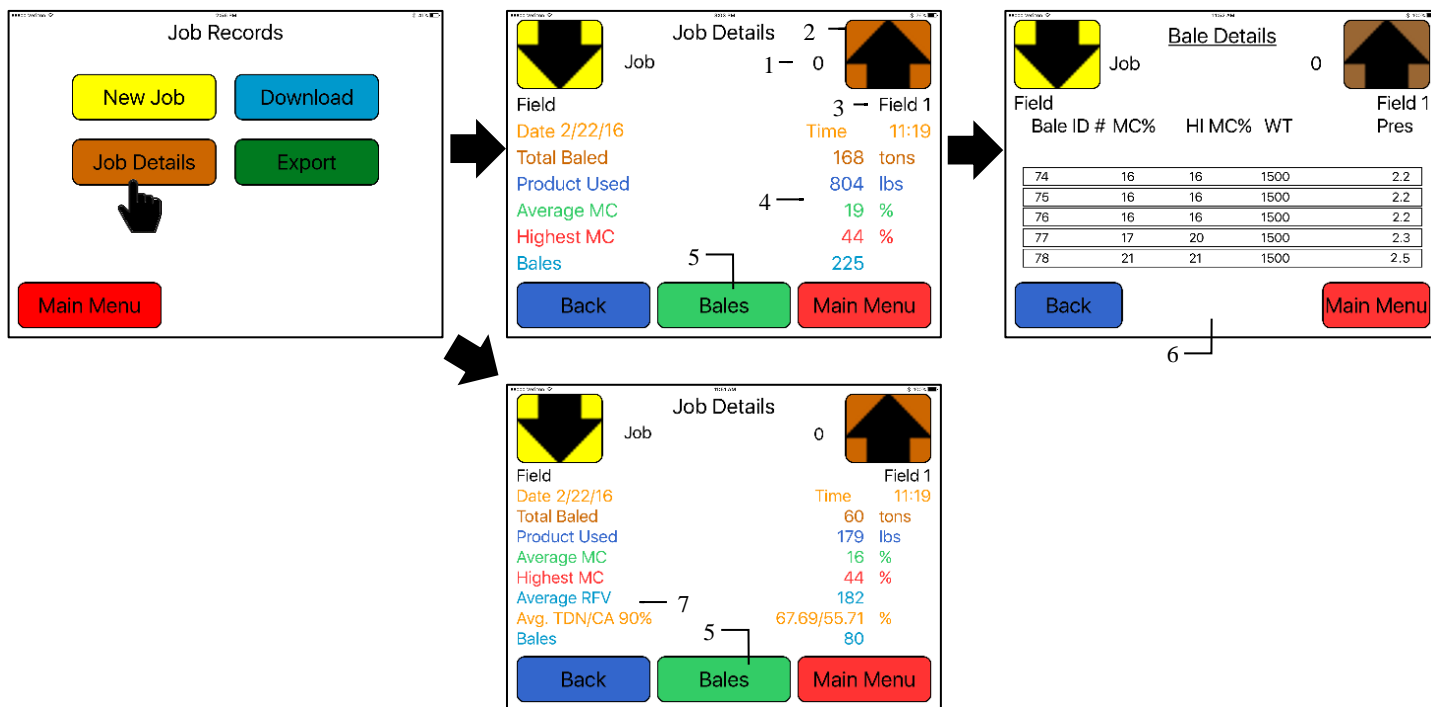

*When RFV Equipped, Average RFV, Ave TDN/CA90% info will be added

1. The job number will be displayed at the top center. The current job being viewed will always read "Job #: 0". Product used and average moisture content will be reset when the NEW JOB key is pressed. The job records screen will store up to 300 jobs allowing access previous jobs by using the up and down arrows.
2. Scrolling through previous jobs is done by pressing the UP or Down keys.
3. The field name is located under the up arrow.
4. The accumulated information from the field will be displayed in the middle of the screen. **Every time the NEW JOB key is pressed the accumulated pounds on auto and manual modes will be reset to zero.** After 300 jobs have been stored, the next time the NEW JOB key is pressed the system will start over with job one and the old job will be replaced.
5. Selecting the Bales button will open the Bale Details Screen.
6. The Bale Detail screen will display the individual bale information onto each line. Including Bale ID#, MC% (moisture percentage), HI MC% (high moisture percentage), WT (weight of bale) and Pres (prservative used per bale).
7. When your applicator system is RFV Equipped, the Average RFV and Avg. TDN/CA 90% calculations will be added to the job details screen.
8. To return the opening screen, press the MAIN MENU key.

NOTE: Initial start-up requires pressing the New Job key in the Job Records screen in order for Volume Used accumulation to be recorded. This only needs to be done once on initial start-up of system and not every time the system is started for operation.

Download Job Records

After pushing the JOB RECORDS key in the Main Menu screen, the following screen will appear:

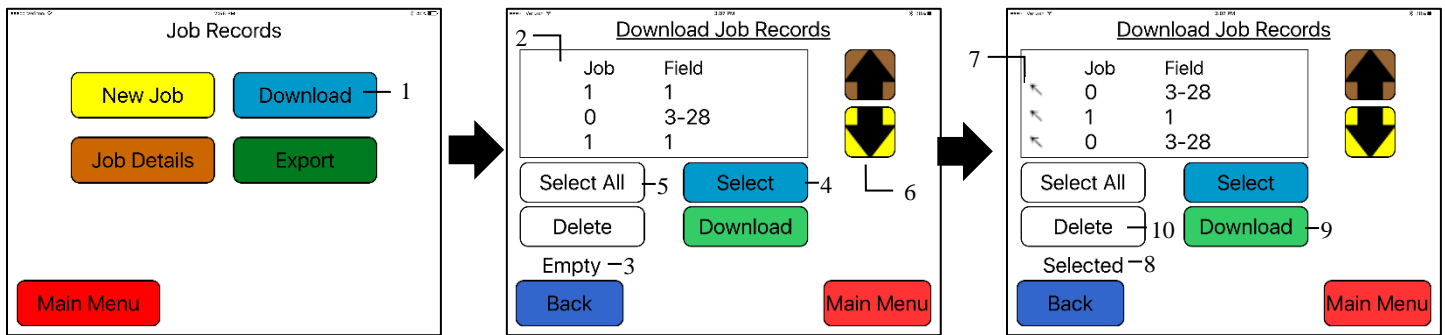

Prior to downloading job records a USB stick will need to be placed into the USB port on the applicator's Dual Channel Processor (DCP). Jobs will not be downloaded if the USB stick is plugged into the monitor.

1. To download the Job Records to a USB stick, select the Download button
2. The list of job records you have created, will display in the middle of the screen
3. When no jobs have been selected the status line will read Empty
4. To download individual job(s), tap the desired job(s) to be downloaded, or press the Select button
5. To select all of the jobs stored, press the Select All Button
6. Move through job records by selecting the up or down arrows
7. The ✓ indicates selected jobs to be downloaded
8. When chosen jobs have been selected the status line will read Selected
9. Press Download button to download job records to USB Stick. The status line will read Downloading
10. Delete selected jobs by pressing the Delete button

Export Job Records (emailing records)

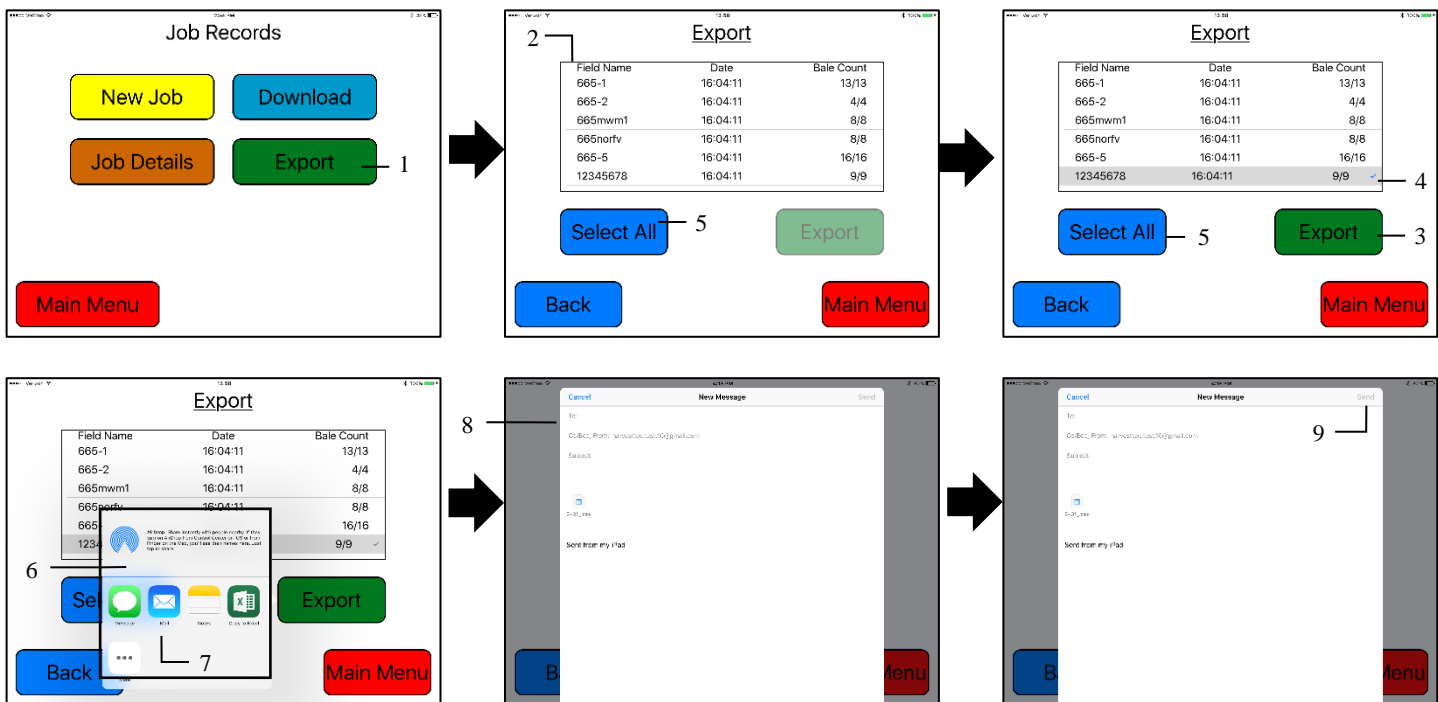

1. To export the Job Records through an email or save to the iPad select the Export button
2. The list of job records you have created, will display in the middle of the screen and the individual bale information will begin to download automatically. The number of bales will grow until equal to the number of bales available to export for each job record.
 - a. For example: When looking at a job record with 62 bales, the bale count will read 0/62 upon initially opening the page. The number will increase until it reads 62/62.
3. When all bales have been retrieved, the Export tab will become active
4. To export individual job(s), tap the desired job(s) to be exported. The ✓ indicated chosen job(s).
5. To select all of the jobs stored to be export, press the Select All Button
6. After selecting the Export tab, a small screen will appear with the mail app icon.
 - a. If selecting two or more jobs the email will automatically appear (skipping step 7)
7. Select the Mail app to open
8. Enter in the desired email address in the (To:) line of the email that will appear.
9. Press the send button to email the file to the email you have entered.

Export Job Records (saving to iPad)

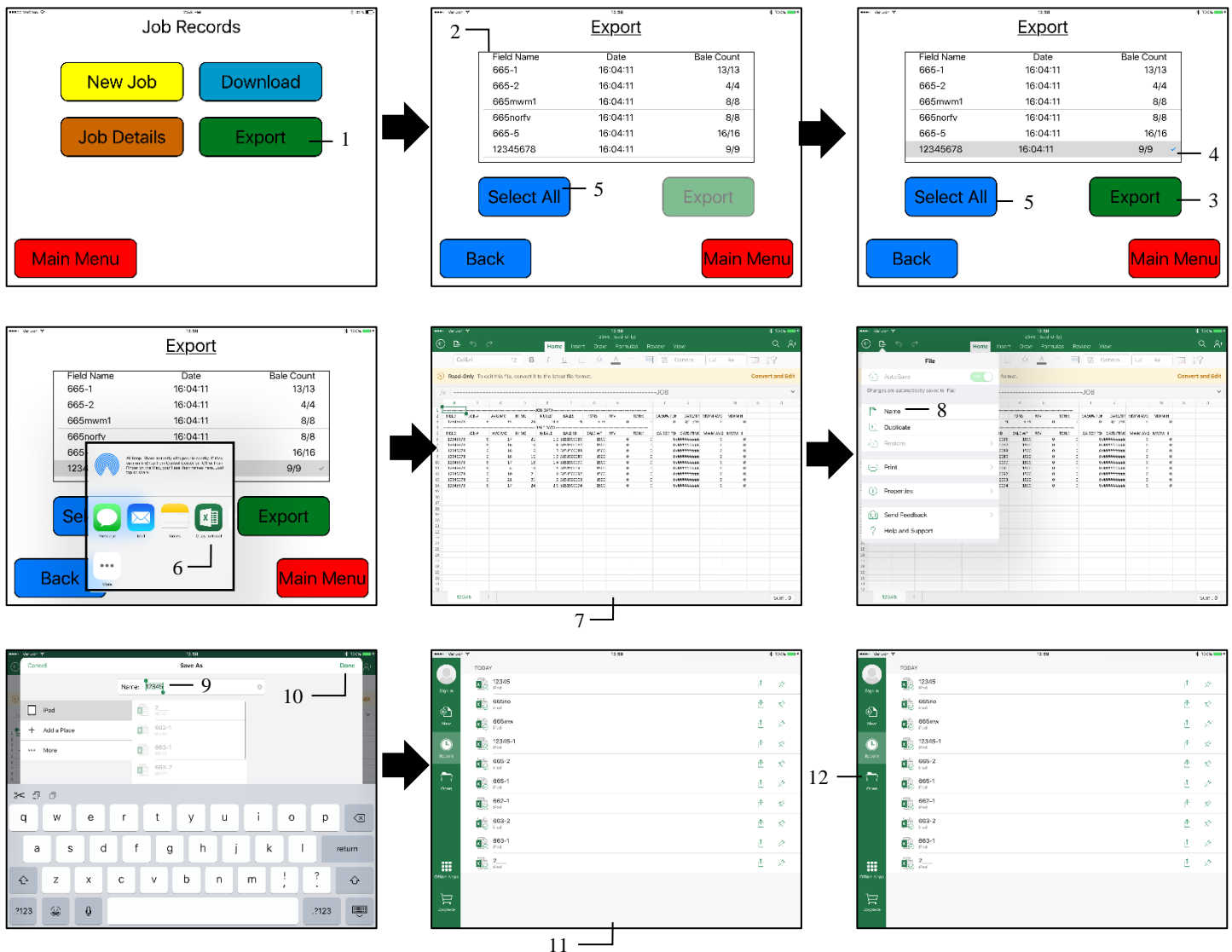

1. To export the Job Records through an email or save to the iPad select the Export button
2. The list of job records you have created, will display in the middle of the screen and the individual bale information will begin to download automatically. The number of bales will grow until equal to the number of bales available to export for each job record.
 - a. For example: When looking at a job record with 62 bales, the bale count will read 0/62 upon initially opening the page. The number will increase until it reads 62/62.
3. When all bales have been retrieved, the Export tab will become active
4. To export individual job(s), tap the desired job(s) to be exported. The ✓ indicated chosen job(s).
5. To select all of the jobs stored to be export, press the Select All Button
6. After selecting the Export tab, a small screen will appear with the Excel app icon.
 - a. It is recommended to download the Excel App to properly view the job records
 - i. Only one job can be selected at a time to view on iPad
7. After the Excel app has been selected the job record spreadsheet will open
 - a. The iPad can only view one job at a time
8. To save the job, select Name from the drop down tab
9. Enter your desired file name
10. Press the save button after entering your file name
11. The list of saved files will appear
12. You can also view the files by selecting the Open tab, when opening the Excel app

Wiring Diagram – Krone ISOBUS Integration (optional)

1. The **Baler Power/Communication Harness** (006-6650LS2(E)) will attach to the open port of the Tractor **Harness** (006-6650TM(E)) and run back to the **Dual Channel Processor** (006-6671LS). Connect the large plug of the Baler Power/Communication Harness (006-6650LS) to the bottom (shorter side) of the DCP.
2. Install green terminator (006-5650Z) to the port labeled **Modular Port** on the Pump Controller (006-5672).
3. Attach moisture and bale rate harness 006-7303H(E) (Claas & Krone kits 006-7303HX(E)) as well as the end of bale harness (006-7400) to the DCP (006-6671LS).
4. Attach the Pump Control Harness (006-5650FM(E)) between the Pump Controller (006-5672) and the DCP (006-6671LS).
5. Connect the orange wires and attach the plug to the tractor's ISOBUS port.
6. If using the optional ISOBUS harness (006-6650VAK) connect one end to the Communication Harness from the DCP and the Power Comm Harness (006-6650LS(E)). The opposite end of the 6650VAK with deutch connections will connect into a 4 pin terminator on the left side of the baler above the baler ECU.
7. Connect the orange keyed power wires (006-5650K) and attach the plug to the tractor's ISOBUS port.

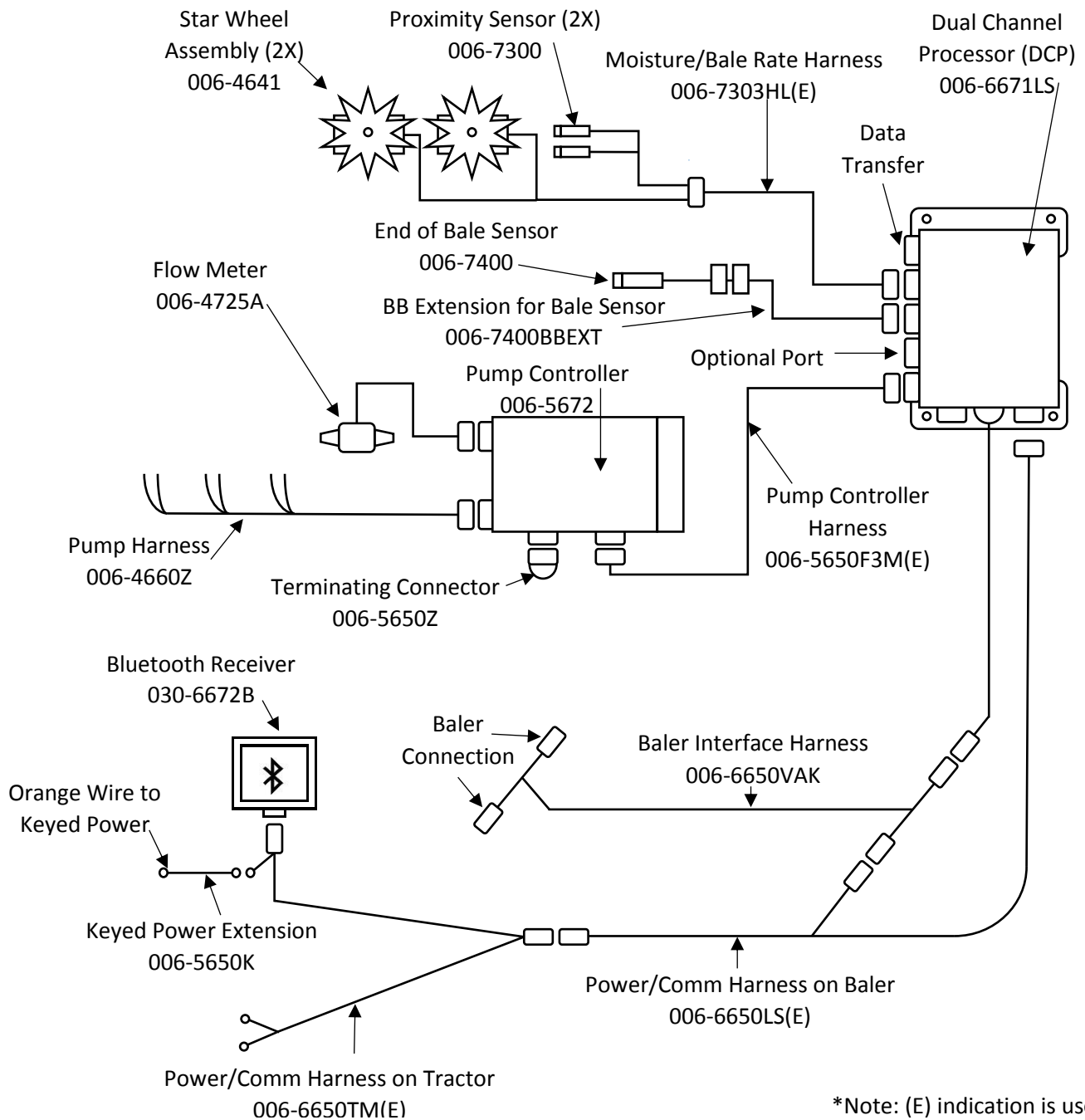

*Note: (E) indication is used for International Dealers

Wiring Diagram

- 1 The **Baler Power/Communication Harness** (006-6650LS2) will attach to the open port of the **Tractor Harness** (006-6650TM) and run back to the **Dual Channel Processor** (006-6671LS). Connect the large plug of the Baler Power/Communication Harness (006-6650LS2(E)) to the bottom (shorter side) of the DCP.
- 2 Install green terminator (006-5650Z) to the port labeled **Modular Port** on the Pump Controller (006-5672).
- 3 Attach moisture and bale rate harness 006-7303H (Claas & Krone kits 006-7303HX) as well as the end of bale harness (006-7400) to the DCP (006-6671LS).
- 4 Attach the Pump Control Harness (006-5650FM(E)) between the Pump Controller (006-5672) and the DCP (006-6671LS).
- 5 Connect the orange wires and attach the plug to the tractor's ISOBUS port.
- 6 If using the optional ISOBUS connector (006-6670B) connect the end to the Communication Harness (006-6650TM(E)) in place of the Bluetooth Receiver shown below.
- 7 Connect the orange keyed power wires (006-5650K) and attach the plug to the tractor's ISOBUS port.

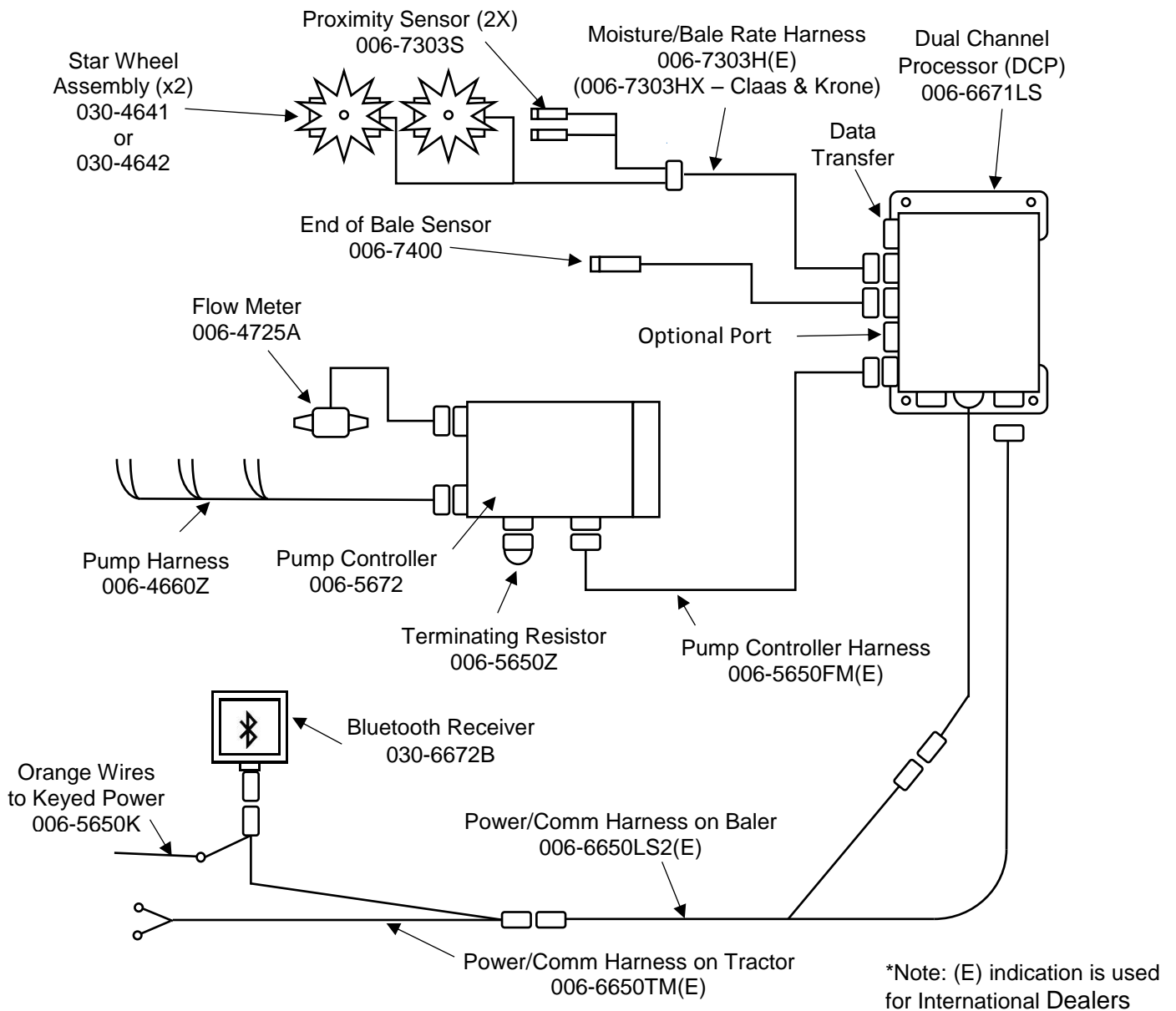

*Claas 3200-3400 balers will have star wheel assembly 030-4642 for mounting on side of bale chamber

Maintenance

- If you are unsure how to perform any of the maintenance steps have your local authorized dealer perform the tasks.

Maintenance Schedule

	Daily	10 hrs	400 hrs	Weekly	Monthly	Season
Diagnostics	X					X
Filter bowl cleaning		X				X
Tips & tip screen cleaning		X				X
Tank lid cleaning		X				X
Dielectric grease connections					X	X
Rebuild pumps			X			
Battery connections				X		X
Check valves			X			
Visually inspect hoses				X		X

Diagnostics: Follow the instructions in this manual to run the Diagnostics mode.

Filter bowl cleaning: The filter bowl is located in front of the applicators tank and is connected to the ball valve. Before cleaning the filter bowl all personal protective equipment must be worn (Face shield or goggles, chemically resistant apron, boots, and gloves).

Verify that the ball valve located next to the pump is turned off. Locate the filter bowl on the side of the pump manifold (A). Unscrew the bottom section of the filter bowl and remove the strainer. (B) Clean off any debris and soak in warm water with a mild soap if necessary. Once the screen is clean reinstall by following the directions in reverse.

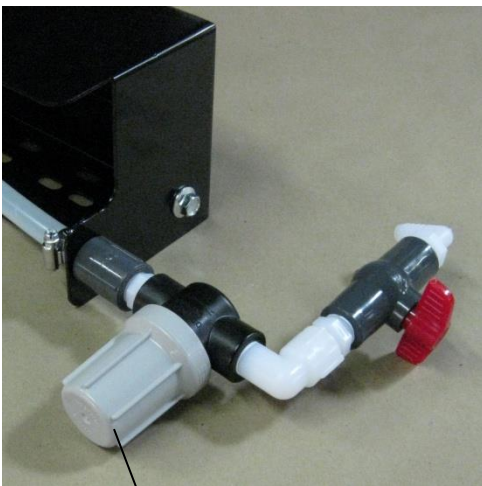

A

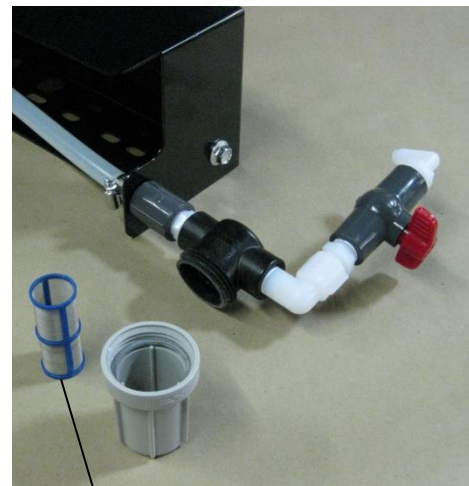

B

Tips and Tip Screen Cleaning: The spray shield assembly that holds the tips and tip screens is located above the pickup head.

Before cleaning the tips and screens all personal protective equipment must be worn (Face shield or goggles, chemically resistant apron, boots, and gloves).

Verify that the ball valve located next to the pump is turned off. Disconnect spray shield from hangers by removing the lynch pins (A). Disconnect check valve nuts and remove hoses from shield (B). Remove shield from baler. Remove all six nozzle caps with a 7/8" wrench (C). Hold the nozzle body from turning while removing the nozzle caps with a 11/16" (17mm) wrench. Remove the tip, and screen. Clean off any debris and soak in warm water with a mild soap if necessary. Once the tips and screens are cleaned reinstall by following the directions in reverse.

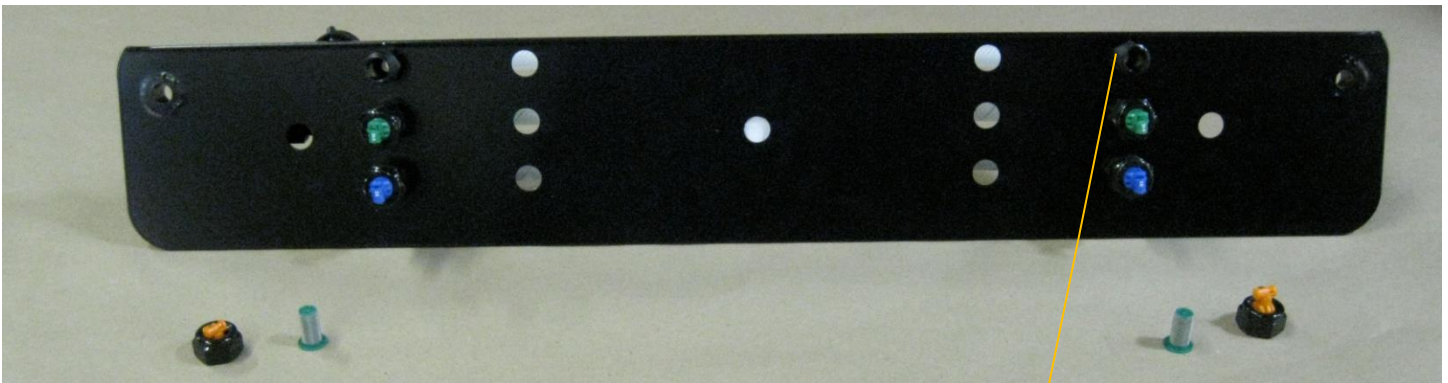
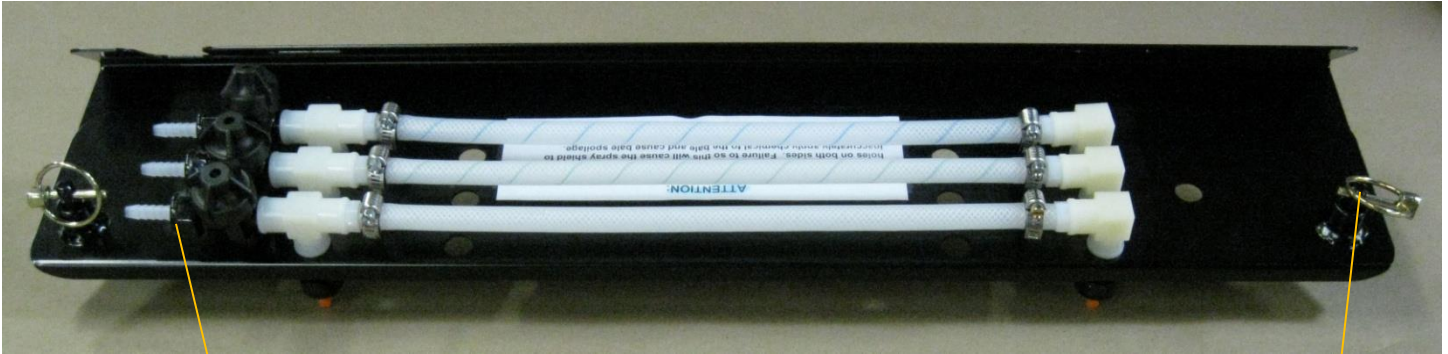

Tank Lid Cleaning: Before cleaning the tank lid all personal protective equipment must be worn (Face shield or goggles, chemically resistant apron, boots, and gloves).

The tank lid is located on the top of the tank. Use the supplied handle on the tank to secure your person and use the other hand to remove any debris from the top of the tank. Unscrew the tank lid and bring down ground level. Use compressed air clean out the tank breather (D). Once the breather is cleaned reinstall the cover.

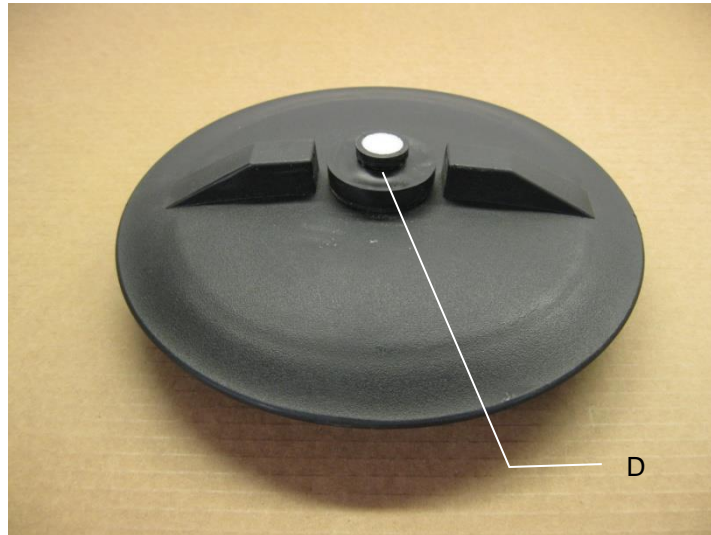

Dielectric Grease Connections: Disconnect all harnesses on the applicator, clean the connections, and repack with dielectric grease.

Rebuild Pumps: If Diagnostic or Manual mode show that the pumps are running lower than normal, a pump rebuild may be necessary. To do this rebuild the pump must be removed from the pump manifold. Pump rebuild is part no. 007-4581. A service pack that includes pump rebuilds and check valves is available from your local dealer.

Verify that the ball valve is turned off. Before working around the pumps all personal protective equipment must be worn (Face shield or goggles, chemically resistant apron, boots, and gloves). Remove pump from manifold. Follow rebuild instructions supplied with pump rebuild kit. Reinstall after rebuild is complete.

Battery Connections: Follow the batteries safety warnings and clean the battery connections. If the connections cannot be cleaned, replace harness.

Check Valves: Before servicing the check valves all personal protective equipment must be worn (Face shield or goggles, chemically resistant apron, boots, and gloves).

Verify the ball valve is turned off before service the check valves. Replace the intake check valves by the pumps (002-4566F) and the discharge check valves by the tip (004-1207VB).

Miscellaneous Maintenance:

1. Depending on the product being used, the system may need to be flushed with water at a regular interval (consult with manufacturer of the chemical.) If Harvest Tec product is being used, flushing is not necessary.
2. Although the pump can run dry, extended operation of a dry pump will increase wear. Watch the preservative level in the tank.
3. If you are using bacterial inoculants, flush your system daily after every use.

Winter Storage

1. Thoroughly flush the system with water.
2. Remove the filter bowl and run dry until the water has cleared out of the intake side.
3. Remove the red plug from the bottom of the pump, drain, and run the pump for 30 seconds or until dry.
4. Drain all lines on the outlet side.
5. Never use oils or alcohol based anti-freeze in the system.
6. For spring start-up, if the pump is frozen, turn off the power immediately to avoid burning the motor out or blowing a fuse. The pump head can be disassembled and freed or rebuilt in most cases. Check the fuses after the pump has been freed.
7. Disconnect power from the Precision Information Processor.
8. Remove display from tractor and store in a warm, dry place.

Status Alerts

Two Status Alerts will appear on the Auto and Manual mode screens when the Job Records are approaching, or full of records.

Status Alert “**Bale Records: Less than 1K remaining**”. The system is now approaching the maximum amount of records that can be saved. When this code appears, download and delete jobs in the Job Records menu. Follow the instructions in Job Records to accomplish this.

Status Alert “**Bale Records failed – Memory Full**”. The system will no longer accept any new data until jobs in the Job Records menu are downloaded and deleted. Follow the instructions in Job Records to accomplish.

Pin Outs

Power/Comm Harness 006-6650TM(E) at Hitch

Pin 1	Red	+12V Power to TSD
Pin 2	Red	+12V Power to DCP
Pin 3	Orange	Keyed Power
Pin 4	Gray	Shield
Pin 5	Green	HT Can Low
Pin 6	Yellow	HT Can Hi
Pin 7	Orange	Can1 Hi
Pin 8	Black	Ground from TSD
Pin 9	Black	Ground from DCP
Pin 10	Blue	Can1 Low



Power/Comm Harness 006-6650LS2(E) at Hitch

Pin 1	Red	+12V Power to TSD
Pin 2	Red	+12V Power to DCP
Pin 3	Orange	Keyed Power
Pin 4	Gray	Shield
Pin 5	Green	HT Can Low
Pin 6	Yellow	HT Can Hi
Pin 7	Orange	Can1 Hi
Pin 8	Black	Ground from TSD
Pin 9	Black	Ground from DCP
Pin 10	Blue	Can1 Low



Bluetooth Receiver on Harness 006-6650TM(E)

Pin 1	Red	+12V Power from DCP
Pin 2	Black	Ground from TSD
Pin 3	Yellow	HT Can Low
Pin 4	Gray	Shield
Pin 5	Green	HT Can Hi
Pin 6	Orange	Can1 Hi
Pin 7	Blue	Can1 Low

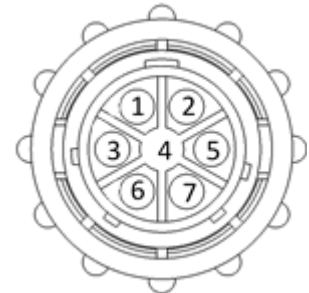

ISOBUS Plug Baler Side

Pin 1	N/A	
Pin 2	N/A	
Pin 3	120 OHM with Pin 5	
Pin 4	N/A	
Pin 5	120 OHM with Pin 3	
Pin 6	Orange	Can1 Hi
Pin 7	Blue	Can1 Low



ISOBUS Plug Tractor Side

Pin 1	N/A	
Pin 2	N/A	
Pin 3	+12V Keyed Tractor Power	
Pin 4	N/A	
Pin 5	N/A	
Pin 6	N/A	
Pin 7	N/A	
Pin 8	Orange	Can1 Hi
Pin 9	Blue	Can1 Low

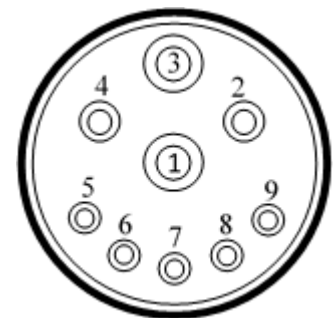

Pin Outs (continued)

Main Power Connector on DCP

Pin 1	Red	+12V Power from tractor
Pin 2	Black	Ground from tractor
Pin 3	Orange	Keyed power

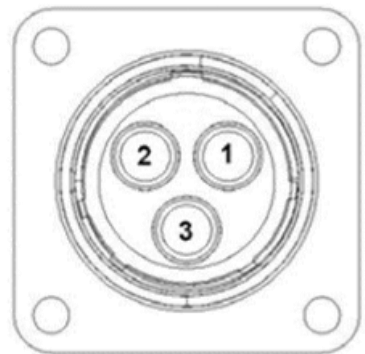

Star Wheel and Bale Rate Sensor connector on DCP

Pin 1	Blue	+12V Power
Pin 2	Orange	Ground
Pin 3	Black	Signal for sensor 1
Pin 4	White	Signal for sensor 2
Pin 5	N/A	
Pin 6	N/A	
Pin 7	N/A	
Pin 8	Violet	Star wheel input 1
Pin 9	Brown	Star wheel input 2



End of Bale sensor on DCP

Pin 1	Brown	Sensor Power
Pin 2	Blue	Sensor Ground
Pin 3	N/A	
Pin 4	Black	Signal from Sensor

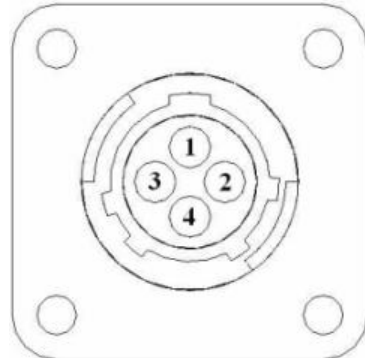

Pump Connection Colors

Pin 1	Black with Orange Stripe	Pump 1 Ground
Pin 2	Black with Green Stripe	Pump 2 Ground
Pin 3	Black with Yellow Stripe	Pump 3 Ground
Pin 4	N/A	
Pin 5	Orange with Black Stripe	Pump 1 Positive
Pin 6	Green with Black Stripe	Pump 2 Positive
Pin 7	Yellow with Black Stripe	Pump 3 Positive

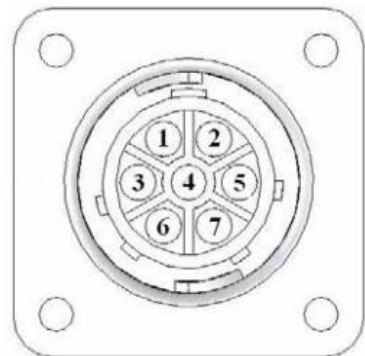

006-6650VAJ Harness to Baler Plug (John Deere Integration)

Pin A	N/A	
Pin B	Red	TBC Power
Pin C	N/A	
Pin D	Gray	TBC Ground
Pin E	Orange	Can1 Hi
Pin F	Blue	Can1 Low

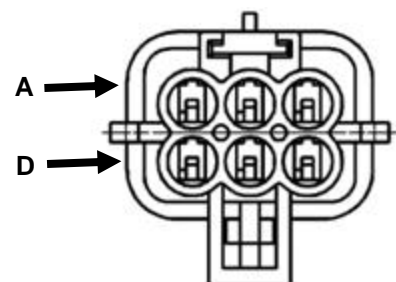

Pin Outs (continued)

Pump Communication Plug on DCP

Pin 1	Red	+12V Can
Pin 2	Red	+12V Power
Pin 3	Gray	Shield
Pin 4	Green	Comm Channel OH
Pin 5	Yellow	Comm Channel OL
Pin 6	Blue	Comm Channel IH
Pin 7	Orange	Comm Channel IL
Pin 8	Black	Can Ground
Pin 9	Black	Power Ground
Pin 10	N/A	

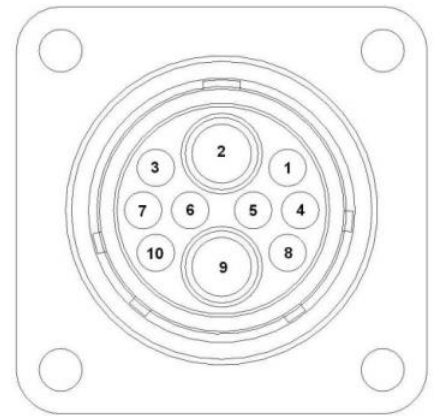

Flow Meter Connection on Pump Controller

Pin 1	White	5 – 12V (+) Supply
Pin 2	Green	Ground
Pin 3	Brown	Signal
Pin 4	Black	Shield

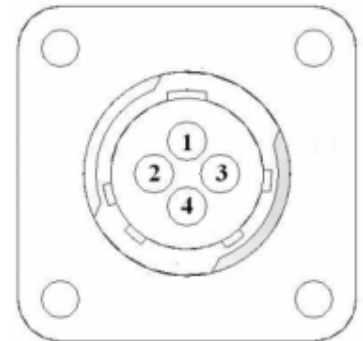

Connector for Crop Eyes on DCP

Pin 1	Red	+12V Power
Pin 2	Black	Ground
Pin 3	White	Signal
Pin 4	N/A	

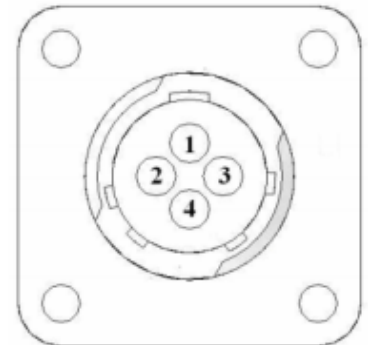

006-6650VAK Harness to Baler (Krone Integration)

Pin 1	Red	Power
Pin 2	Orange	CAN1_H
Pin 3	Black	RTN
Pin 4	Blue	CAN1_L

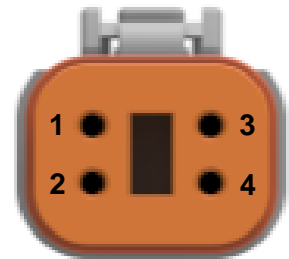

Pump Communication Plug on DCP

Pin 1	Red	+12V Can
Pin 2	Black	+12V Power
Pin 3	Yellow	Shield
Pin 4	Gray	Comm Channel OH
Pin 5	Green	Comm Channel OL
Pin 6	Orange	Comm Channel IH
Pin 7	Blue	Comm Channel IL

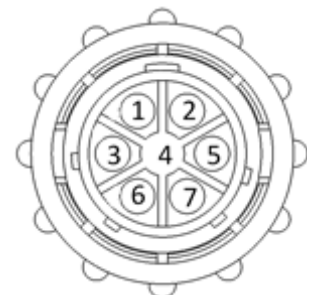

Common Questions

1. How do I turn the system on/off?

Turn the key in the tractor to the ON/OFF position.

2. How to get in the LBS/TON, MC%, and TONS/HR menus?

In the **Main Menu** press the **Setup Mode** option. From this screen you can change your application rates and how much product is applied. See the section on **Setting Up For Initial Use** for a detailed explanation of this process.

3. The unit is stuck in the MC% screen.

In the MC% screen, level 1 must be less than level 2, and level 2 must be less than level 3. For example, if level 1 is set at 16, level 2 must be set at 17 or higher, and level 3 must be set higher than level 2.

4. How does Override work?

Override turns on all three pumps at full output. The pumps will remain at full output until the operator turns these pumps off by pressing the **Override** key again.

5. The flow meter reading is more or less than the programmed level set in the box.

Some variation in flow meter readings compared to the programmed set point is normal due to factory tolerances on the pump motors as well as varying tractor voltages inputted to the control box. The flow meter reading is an accurate measure of how much product is actually being applied. The set points then will need to be adjusted if you want to attain a different flow meter reading.

6. Why don't all the pumps turn on even at higher application rates?

The selections of what pumps turn on when are automatically controlled by the control box's flow rate look up chart. Thus, not all the pumps turn on at once and the combination of what pumps turn on when is automatically controlled by the software. If you want to make sure all three pumps are working, go to the Diagnostics screen and run pump outputs.

7. The moisture content displays "LO" or "HI" all the time.

When the moisture content display does not change frequently while baling, there is likely a faulty star wheel connection. One of the first places to check is inside the white star wheel block. Check to see if the electronic swivel is in the star wheel shaft and check to see that the star wheel shaft is not working out of the block. Also, check all star wheel wires and connectors to see if there is a continuity or grounding problem.

8. Should the battery connections be removed before jump starting or charging a battery?

Yes. Anytime the tractor will have voltage going up rapidly the connections should be removed.

9. How can I turn the optional hay indicators Crop Eyes On/Off from the cab?

From the **Setup Mode** screen press **Options**. Press the **On/Off** underlined area next to **Crop Eyes**.

10. Bale scale does not give a consistent reading.

Baling on rough terrain or hills can cause the scale to give an inaccurate reading. Turn Bale Scale option OFF in the Bale Rate Screen and use AVG Bale Weight reading as weight of bale.

11. What do the lights on the 030-6672B indicate?

Red Light – The Bluetooth receiver has power. *Green Light* – When the proper active connection is selected in the Hay App menu, the green light will indicate connection with the iPad.

Troubleshooting

Problem	Possible cause	Solution
Pump will not run.	1. No voltage to DCP or Pump controller.	1. Check for short, low voltage, and replace fuse(s) if necessary.
	2. Pump locked up.	2. Clean or rebuild pump if motor is OK.
	3. Damaged wire.	3. Repair damaged wire.
	4. Fuse blown on Pump controller.	4. Replace fuse and check pump for short in wire or locked motor.
Pump runs but will not prime.	1. Air leak in intake.	1. Tighten fittings on intake side.
	2. Clogged intake.	2. Clean.
	3. Restricted outlet.	3. Check and clean tips.
	4. Check valve on the outlet is stuck closed.	4. Clean or repair check valve.
	5. Dirt inside pump.	5. Replace pump check valve.
Pump does not develop enough output.	1. Air leaks or clogs on inlet side.	1. Tighten or clean filter bowl assembly.
	2. Pump worn or dirty.	2. Rebuild pump.
Moisture reading errors (high or low)	1. Wire disconnected or bad connection between star wheels and DCP	1. Reconnect wire.
	2. Low power supply to DCP	2. Check voltage at box. (Min of 12 volts required.) See Diagnostics section of manual.
	3. Wet hay over 75% moisture	
	4. Ground contact with one or both star wheels and baler mounted processor.	4. Reconnect.
	5. Short in wire between star wheels and DCP.	5. Replace wire.
	6. Check hay with hand tester to verify.	6. Contact Harvest Tec if conditions persist.
Moisture readings erratic.	1. Test bales with hand tester to verify that cab monitor has more variation than hand tester.	
	2. Check all wiring connections for corrosion or poor contact.	2. Apply dielectric grease to all connections.
	3. Check power supply at tractor. Voltage should be constant between 12 and 14 volts.	3. Install voltage surge protection on tractors alternator.
Flow meter readings do not match up with product usage.		
Product is less than actual product used.	1. Voltage supplied to meter is less than 6 volts.	1. Check for a min of 6 volts supplied at Pump controller.
	2. Wiring short in signal to baler mounted processor.	2. Inspect wire and replace if necessary.
	3. Clog in meter.	3. Back flush with water, NOT AIR
	4. Using product other than Harvest Tec	4. Catch and weigh product to check outputs.
Product shown is more than actual product used.	1. High voltage supplied to the meter.	1. Check voltage at Pump controller. Max of 18 volts.
	2. Light interference with meter.	2. Reflection into meter can cause a high reading. Move meter or protect from sunlight.
	3. Air leak in intake.	3. Look for air bubbles in line. Replace line or other defective area that is allowing air into the system.
	4. Using product other than Harvest Tec	4. Catch and weigh product to check outputs.
System leaks product after shut down.	1. Dirty or defective check valves.	1. Clean or Replace.
Terminal reads under or over power.	1. Verify with multi-meter actual	1. Clean connections and make sure

	voltage. Voltage range should be between 12-14 volts.	applicator is hooked to battery. See Diagnostics section of manual.
System does not pause at the end of a row.	<ol style="list-style-type: none"> 1. Short in cable. 2. Damaged sensor. 3. Bad alignment of sensors 	<ol style="list-style-type: none"> 1. Replace cable. 2. Replace sensor 3. Check 474 manual for alignment instructions
Bale rate displays zero.	<ol style="list-style-type: none"> 1. Bale rate sensors are reversed. 2. Short in cable. 3. Damaged sensor. 	<ol style="list-style-type: none"> 1. Switch the sensors next to the star wheel. 2. Replace cable. 3. Replace sensor.
Display says PAC error	<ol style="list-style-type: none"> 1. The DCP and Pump controller are not communicating. 2. Broke connection between the display and DCP or Pump control and DCP. 	<ol style="list-style-type: none"> 1. Check all connections at DCP and Pump controller including terminating resistors. 2. Check, clean, and tighten connections.
Bluetooth Receiver lights will not illuminate	<ol style="list-style-type: none"> 1. Bluetooth receiver not connected 2. Harness disconnected 3. Low power 	<ol style="list-style-type: none"> 1. Check connections and voltage. Minimum 12.5V needed.
	<p>Blinking Lights – System is waiting for the processor to connect, which could take up to 35 seconds.</p> <p><i>Red Light</i> – The Bluetooth receiver has power</p> <p><i>Green Light</i> – When the proper active connection is selected in the Hay App menu, the green light will indicate connection with the iPad.</p>	

iPad Troubleshooting

iPad Symptom	Troubleshooting
iPad won't turn on	<p>- Turn your iPad off and on. Press and hold the Sleep/Wake button for a few seconds until a red slider appears; then slide it. Press and hold the Sleep/Wake button to turn on again.</p>
	<p>-Reset your iPad. Press the "Sleep/Wake" button and the "Home" button simultaneously for at least 10 seconds until the Apple logo appears on the screen. This reset will not damage your files.</p>
	<p>You may have a drained battery. Plug your iPad into your computer or AC adapter and see if anything happens. Ideally your iPad will recognize it has been connected to a power source and charge its battery. If it will no longer charge, the battery must be swapped with a replacement battery. Battery level is display in top right corner of iPad.</p>
iPad won't connect to Bluetooth accessory	<p>-Make sure that your Bluetooth accessory and iOS device are close to each other when connecting.</p>
	<p>-Make sure that your Bluetooth accessory is on and fully charged or connected to power. If it uses batteries, test them to see if they need to be replaced.</p>
	<p>-Restart your Bluetooth receiver, by removing power and reconnecting after 30 seconds.</p>
	<p>-Make sure that you have at least a 3rd generation iPad with iOS8 or greater operating system on your iPad</p>
	<p>-On your iPad, go to Settings > Bluetooth and make sure that Bluetooth is on. If you can't turn Bluetooth on or you see a spinning gear, restart your iPad</p>
	<p>-Unpair the Bluetooth accessory, put the accessory back in discovery mode, then pair and connect it again. By tapping on its name in the Bluetooth accessories tab and then Forget this Device. In settings, tap on a device's name, then Unpair.</p>
iPad touchscreen is slow or does not respond	<p>-It may be that your screen is dirty. Try cleaning your screen. To do this, unplug everything, turn off iPad then with a very soft, lint-free and slightly damp cloth gently wipe the screen. Do NOT use window cleaners and paper towels.</p>
	<p>-If you have any screen protector sheet, try removing it.</p>
iPad is not charging or is slow to charge	<p>-In order to charge your iPad you can try either connecting your iPad to a power outlet or connecting to a USB 2.0 port on a computer. However, note that computers generally don't supply enough power to their USB ports to be able to charge an iPad. When this happens, a "Not Charging" message will appear.</p>
How can I unlock my iPad if I forgot the passcode	<p>If you cannot remember the passcode, you will need to <i>restore your device using the computer with which you last synced it</i>. This allows you to reset your passcode and resync the data from the device (or restore from a backup). If you restore on a different computer that was never synced with the device, you will be able to unlock the device for use and remove the passcode, but your <i>data will not be present</i>.</p>
How do I send in my iPad for service?	<p>Refer to your iPad owner's manual or contact apple customer service. DO NOT SEND iPad TO HARVEST TEC.</p>
<p>For other issues refer to your iPad Owner's Manual or contact Apple Directly</p>	

***Harvest Tec Does Not Service iPads ***

Parts Breakdown Tank, Saddle & Legs 100 Gallon

Vermeer, Claas, and Krone Balers with 100 gallon tank

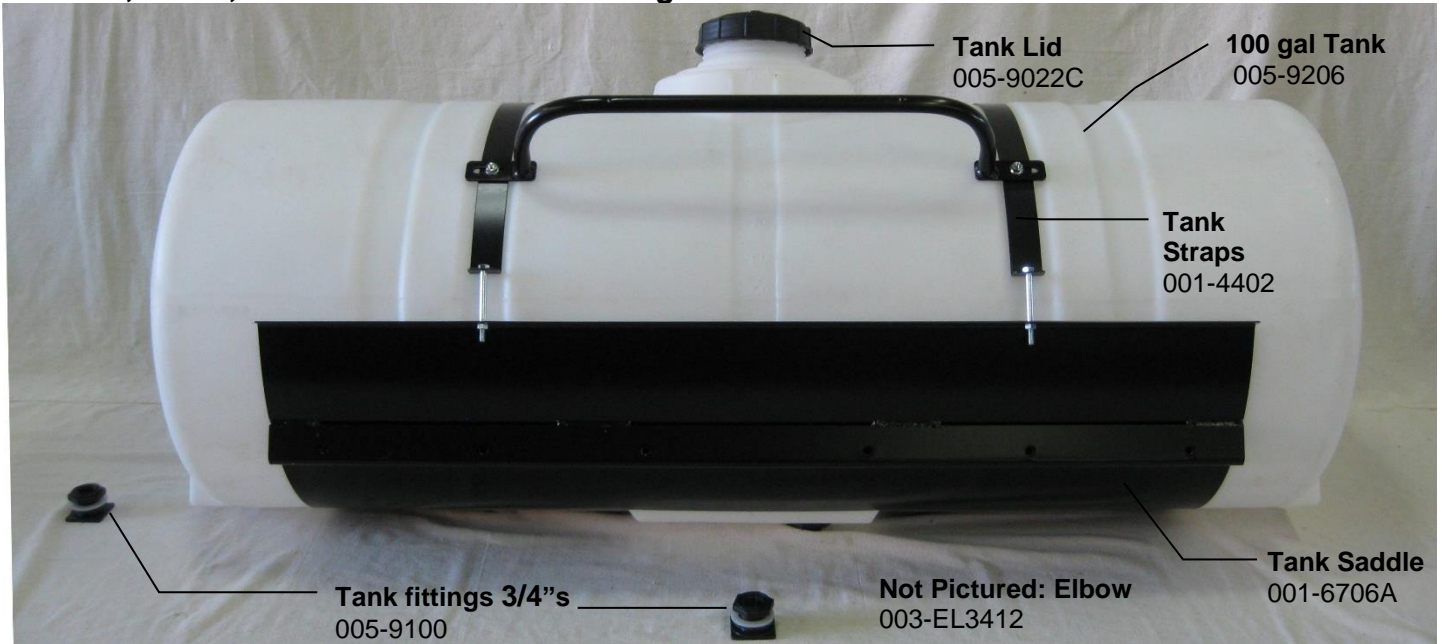

Vermeer, Claas and Krone Balers Saddle Legs

Part#: 001-6706V

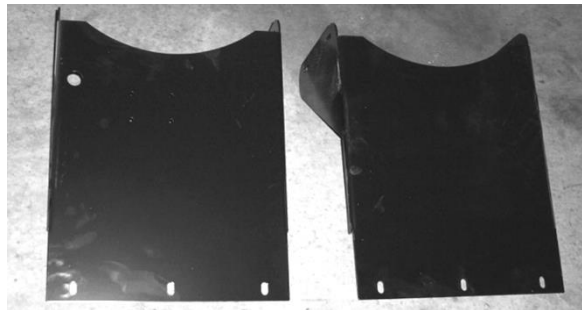

*If the applicator is being mounted on a **Krone 870 HDP** baler, two leg adapter brackets will be needed for proper tank leg installation (below). Part number 001-6707KV.

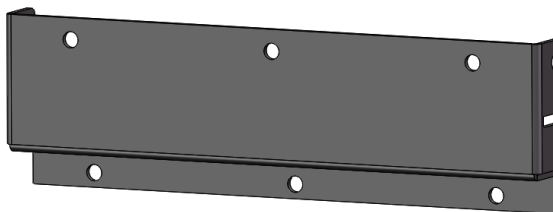

Claas 3300 Saddle Legs

Part #: 001-6706C



Tank, Saddle and Legs 110 Gallon



- Tank Lid**
Part#: 005-9022E
or 005-9208L
- Tank-110 gallon**
Part#: 005-9208
- Hand Rail**
Part#: 001-6707HR
- Tank Straps**
Part#: 001-4402B
- Tank Saddle**
Part#: 001-6707A
- Tank Fitting**
Part#: 005-9100

Not Pictured: Elbow
Part#:003-EL3412

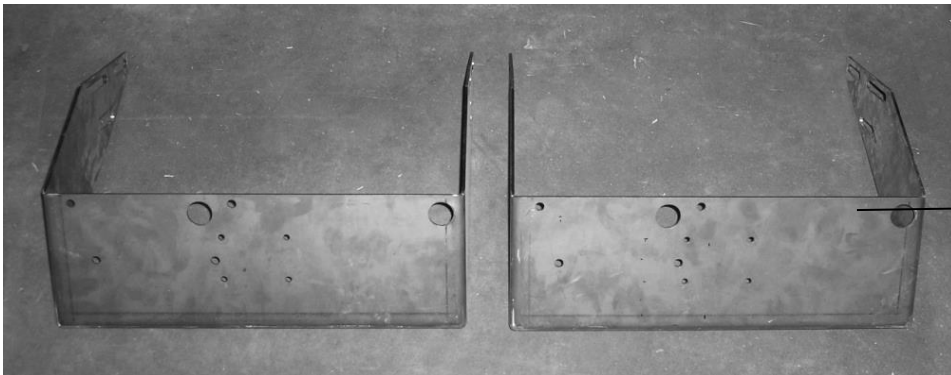

Agco, Hesston, Massey & Challenger Saddle Legs

Part#: 001-6707C

**New Holland BB940A, BB960A,
Case IH LBX 332, LBX 432 Series
Saddle Legs**

Not Pictured:
Vicon Leg Spacers:
Part#: 001-6707BS (x2)

Handrail:
Part#: 001-6707HR (x1)

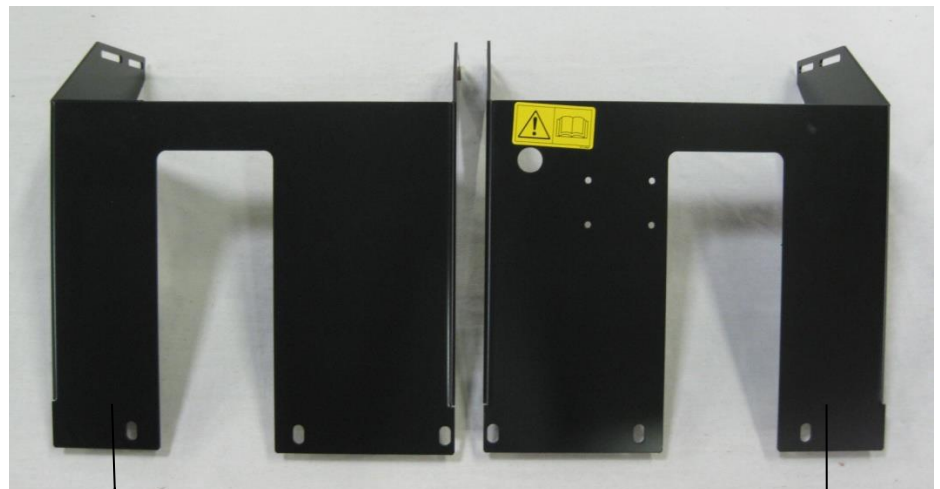

Left Leg Part#:001-6707BL
(2010 and older 4 ft wide)

Right Leg Part #:001-6707BR
(2010 and older 4 ft wide)

Tank, Saddle and Legs 110 Gallon (continued)

**New Holland BB940A, BB960A,
Case IH LBX 332, LBX 432 Series
Saddle Legs**



Left Leg Part#: 001-6707DL
(2011 and newer 4 ft wide)

Right Leg Part #: 001-6707DR
(2011 and newer 4 ft wide)

Krone Balers

Part#: 001-6707KA

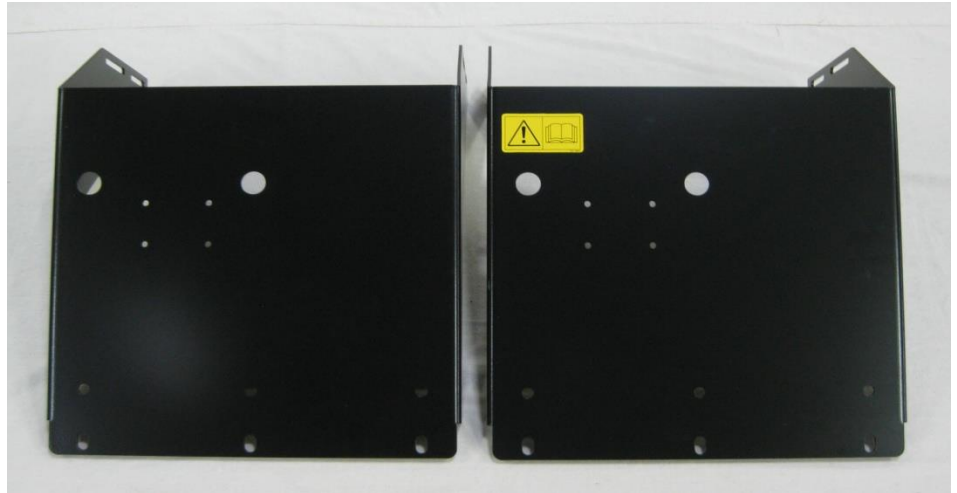

Parts Breakdown for Pump Manifold

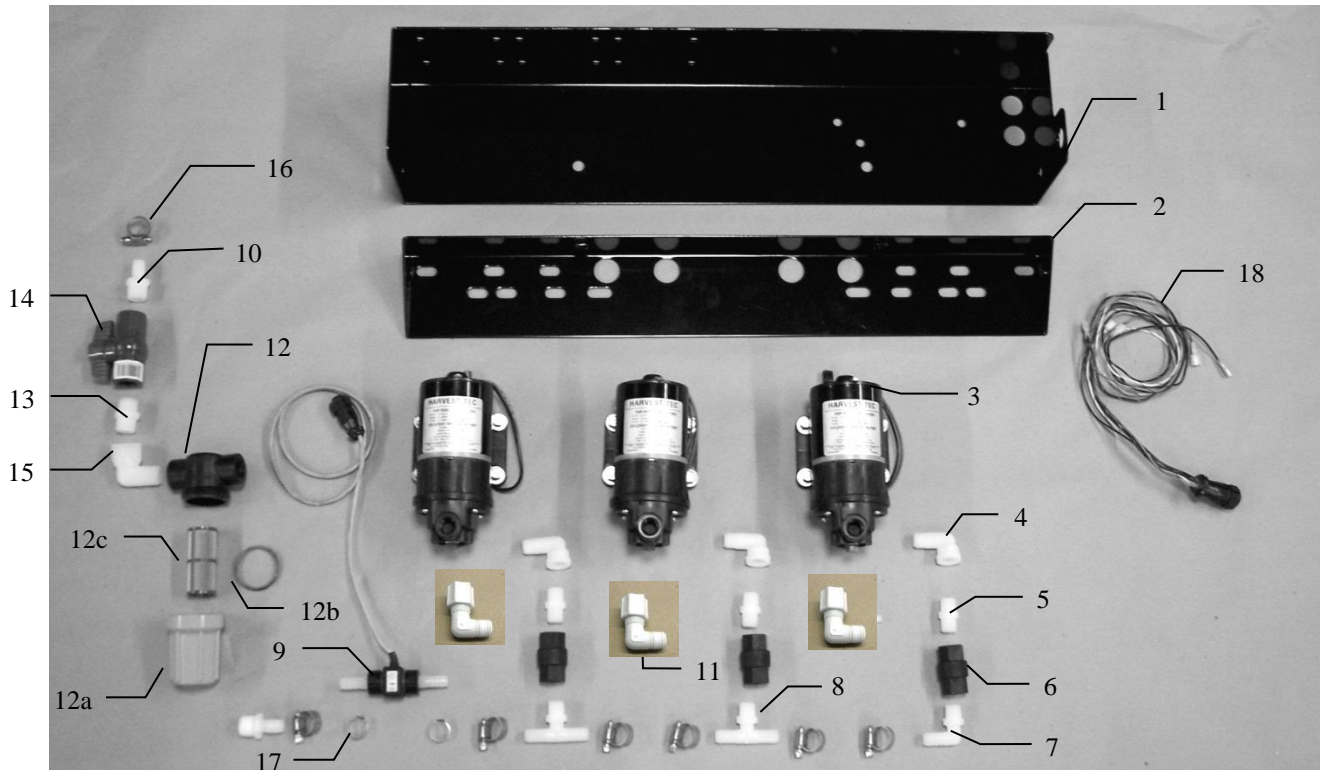

<u>Ref#</u>	<u>Description</u>	<u>Part#</u>	<u>Qty</u>
1	Pump plate	001-4646D	1
2	Mounting Bracket	001-4646C	1
3	Pump	007-4120H	3
4	Street elbow fitting	003-SE38	3
5	Nipple fitting	003-M3838	3
6	Check valve	002-4566F	3
7	Elbow fitting	003-EL3812	1
8	Tee fitting	003-T3812HB	2
9	Flow meter assembly	006-4725A	1
10	Straight fitting	003-A1212	2
11	Jaco fitting	003-JEL1238	3
12	Filter bowl assembly	002-4315-100	1
12a	Filter bowl only	002-4315F	1
12b	Filter bowl gasket	002-4315D	1
12c	Filter bowl screen	002-4315A	1
13	Nipple fitting	003-M1212	1
14	Ball valve	002-2212	1
15	Street elbow fitting	003-SE12	1
16	Hose clamp	003-9003	7
17	Hose clamp (Flow Meter)	003-9005	2
18	Pump Cable	006-4660Z	1
NP	Elbow	003-EL1212	1
NP	Pump rebuild kit (1 per pump)	007-4581	1
NP	Not Pictured		

Parts Breakdown for Star Wheel Moisture Sensors

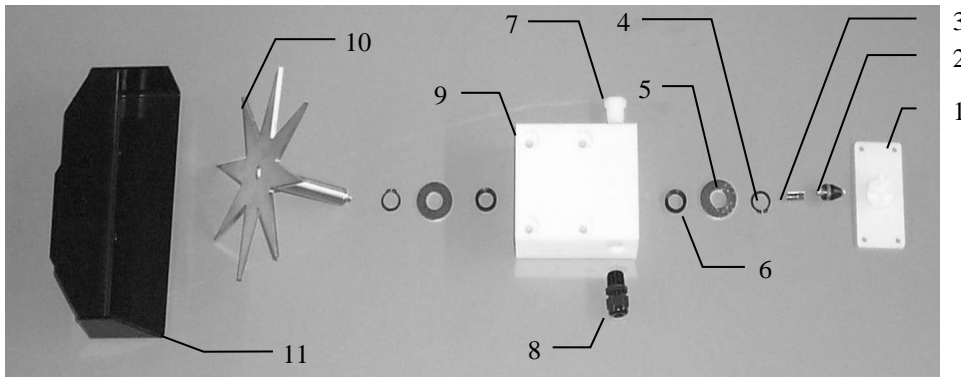

<u>Ref</u>	<u>Description</u>	<u>Part#</u>	<u>Qty</u>	<u>Ref</u>	<u>Description</u>	<u>Part#</u>	<u>Qty</u>
1	Block cover	006-4641B	2	9	Star wheel block	006-4641A	2
2	Electronic swivel	006-4642A	2	10	Star wheel sensor	030-4641C	2
3	Swivel insert	w/ Ref # 10	2	11	Twine guard-left	001-4645	1
4	Snap ring (per side)	006-4641K	2		Twine guard-right (prox)	001-4644	1
5	Washer (per side)	w/006-4641K	2				1
6	Dust seal (per side)	w/006-4641K	2				1
7	Plug fitting	003-F38	2	1-10	Star wheel assembly	030-4641	2
8	Wiring grommet	008-0821A	2				

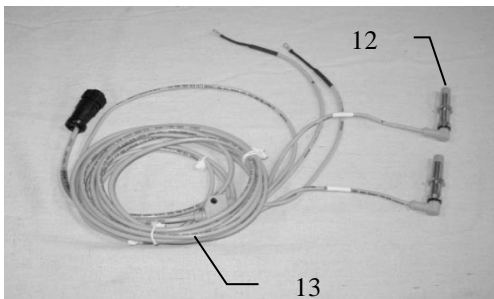

<u>Ref</u>	<u>Description</u>	<u>Part#</u>	<u>Qty</u>
12	Bale rate sensor	006-7303S	2
13	Moisture and bale rate harness	006-7303H	1
	Claas & Krone	006-7303HX	
	Complete Assembly	006-7202	

Vicon, Kuhn, Krone, Claas 3200-3400

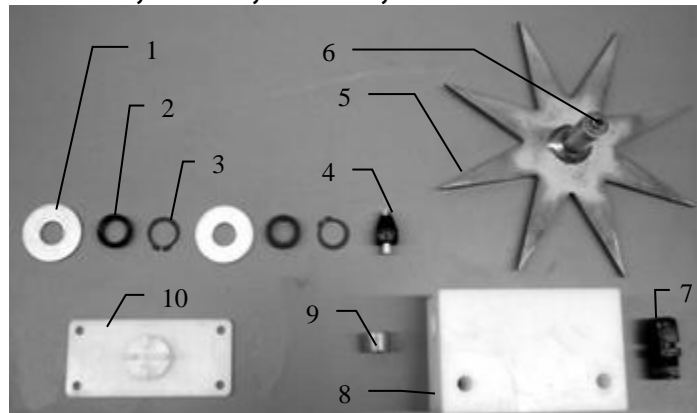

<u>Ref</u>	<u>Description</u>	<u>Part#</u>	<u>Qty</u>	<u>Ref</u>	<u>Description</u>	<u>Part#</u>	<u>Qty</u>
1	Washer (per side)	006-4642K	2	8	Star wheel block	006-4641A	2
2	Dust seal (per side)	w/006-4642K	1	9	Plug fitting	003-F38	2
3	Snap ring (per side)	w/006-4642K	2	10	Block Cover	006-4641B	2
4	Swivel	006-4642A	2	1-10	Star wheel assembly	030-4642	2
5	Star wheel	030-4641E	2	NP	Twine guard – right (prox)	001-4644	1
6	Insert	w/ Ref # 5	2	NP	Twine guard - left	001-4645	1
7	Wiring grommet	008-0821A	2				

Parts Breakdown for 696 Series Control and Harnesses Dual Channel Processor (DCP)



<u>Ref</u>	<u>Description</u>	<u>Part Number</u>	<u>Qty</u>
1	Pump Controller	006-5672	1
2	End of Bale Sensor	006-7400	1
3a	Hesston 4755, 4910 EOB Mount	001-4648H	1
3b	EOB Bracket CLAAS 3300	001-4648C	1
3c	Krone EOB Bracket	001-4648K2	1
3d	EOB BKT Krone 12130	001-4648K	1
3e	End of Bale Sensor Bracket	001-4648	1
4	DCP Shield Cover	001-5650X	1
5	DCP Main Control LS 600 AUTO	006-6671LS	1
6	Terminating Connector w Green Cap	006-5650Z	1
7	DCP Baler Harness 30 Ft	006-6650LS2	1
8	Modular Power/Comm 10 Ft Harness	006-5650FM	1
9	Optional ISOBUS Tractor Plug (not included)	006-6670A	1
10	DCP Tractor Harness	006-6650TM	1
11	Key Switch Wire	006-5650K	1
12	Dust Plugs	006-5651PLUGS	1
13	Bluetooth Receiver	030-6672B	1
NP	Krone Integration Harness (optional)	006-6650VAK	1

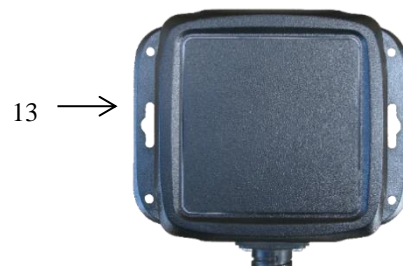

Parts Breakdown for Hose and Drain Fill Line

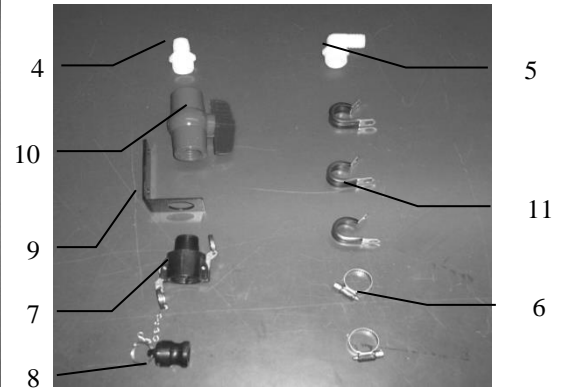
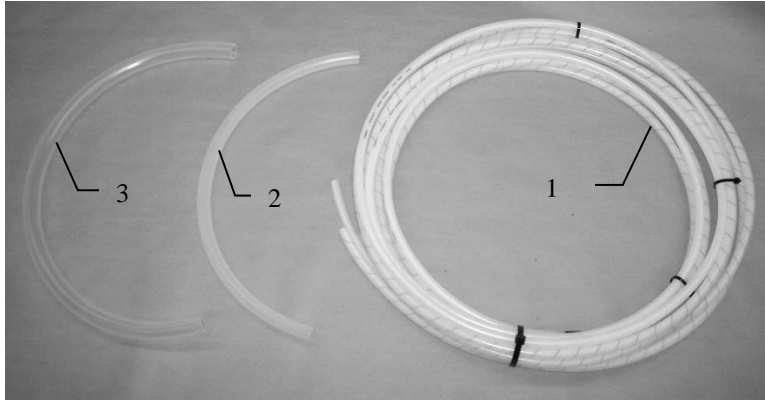

<u>Ref</u>	<u>Description</u>	<u>Part#</u>	<u>Qty</u>	<u>Ref</u>	<u>Description</u>	<u>Part#</u>	<u>Qty</u>
1	Triple weld hose (pumps to tips)	002-9016	35ft	7	Female Coupler	002-2204A	1
		002-9016B	35ft	8	Male Coupler	002-2205G	1
		002-9016G	35ft	9	Valve Holder	001-6702H	1
	Three hose assembly	030-9016LS	1	10	Ball valve	002-2200	1
2	1/2" Hose (tank to filter)	002-9001	6ft	11	Jiffy Clip	008-9010	3
3	3/4" Hose (tank to drain/fill valve)	002-9002	10ft				
4	Straight Fitting	003-A3434	1				
5	Elbow	003-EL3434	1				
6	Hose Clamps	003-9004	2				

Optional iPad Mini Mounting Kit (030-2014MK)

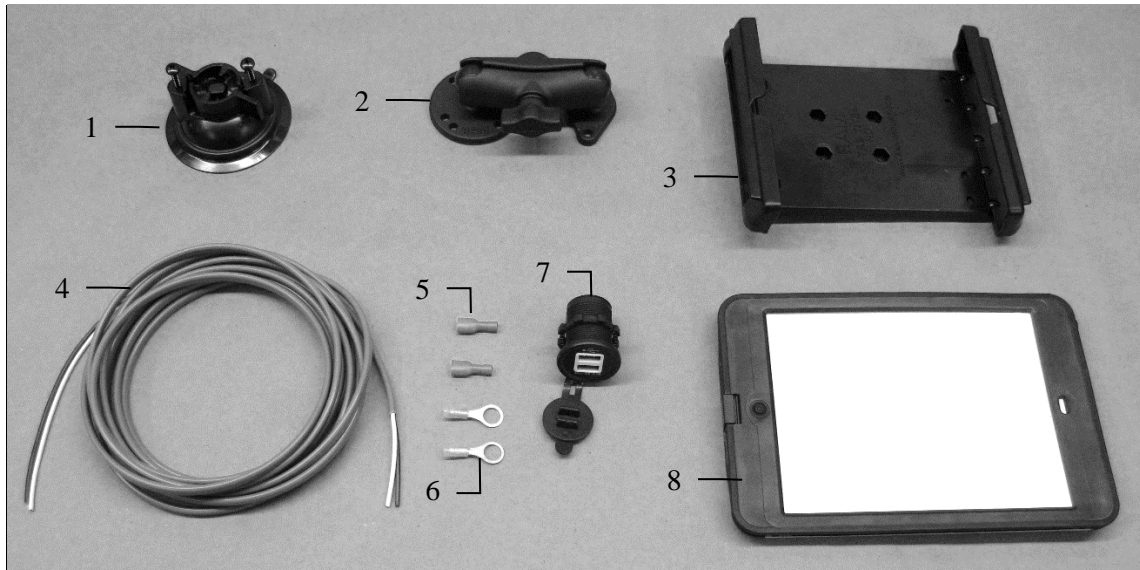

<u>Ref</u>	<u>Description</u>	<u>Part #</u>	<u>Qty</u>
1	Suction cup mount	001-2012SCM	1
2	Ram mount	001-2012H	1
3	iPad Mini spring load cradle (Mini 4)	001-2012SLC	1
4	16 gauge power wire	006-4723P	1
5	Female spade connector	Hardware	2
6	Eye loop connector	Hardware	2
7	iPad Mini Charger 12V	001-2012P	1
8	iPad Mini 4 case	001-2012C4	1
NP	4 amp fuse	Hardware	1
Mounting Kit Assembly		030-2014MK (Includes All Parts)	

Installation Instructions

1. Identify 12V power source for wires to connect.
 - a. Eye loops included if wiring directly to the battery is desired.
 - b. Test for key power source if preferred to have power to the USB shut off with the key.
2. Once power source is identified, cut wires to desired length.
3. Crimp the two supplied quick connectors onto each the white and black wire.
4. Remove the round locking plastic nut from USB plug before connecting the wires. Black (+) White (-).
5. The wires will then be hooked to the designated terminals on the bottom of the USB plug
6. Drill a 1 1/8" hole in the preferred mounting location. Be sure to clean any sharp edges after drilling.
7. Feed the wires through the mounting hole.
8. If using the round plastic nut to secure plug in place, slide the nut back over the wiring before connecting the wires to powered source.
9. Connect the wires to the identified power source if easier to do so before tightening the plug into place.
10. Tighten plug using either the round plastic nut or mounting plate and two screws, both options supplied.
11. Once connected, hook a USB charging cord into the plug and connect a mobile device/tablet to ensure the plug is operating as you wish (key power working properly if necessary).

NOTE: This plug is not designed to charge two iPads. System damage could occur if this is attempted. System will charge a mobile phone and iPad simultaneously without problem.

Optional iPad Display Kit (030-4670DK)

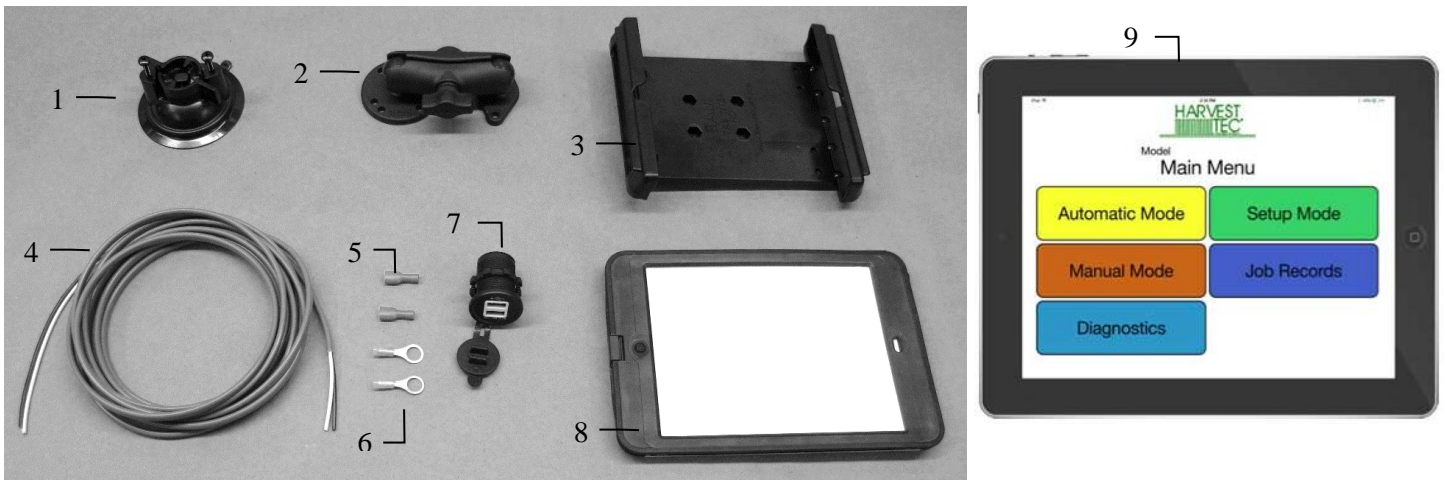

<u>Ref</u>	<u>Description</u>	<u>Part #</u>	<u>Qty</u>	<u>Ref</u>	<u>Description</u>	<u>Part #</u>	<u>Qty</u>
1	Suction cup mount	001-2012SCM	1	7	iPad Mini Charger 12V	001-2012P	1
2	Ram mount	001-2012H	1	8	iPad Mini 4 case	001-2012C4	1
3	iPad Mini spring load cradle (Mini 4)	001-2012SLC	1	9	iPad Mini 4	006-4670IP	1
4	16 gauge power wire	006-4723P	1	NP	4 amp fuse	Hardware	1
5	Female spade connector	Hardware	2		Mounting Kit Assembly	030-4670DK	
6	Eye loop connector	Hardware	2			(Includes All Parts)	

Installation Instructions

1. Identify 12V power source for wires to connect.
 - a. Eye loops included if wiring directly to the battery is desired.
 - b. Test for key power source if preferred to have power to the USB shut off with the key.
2. Once power source is identified, cut wires to desired length.
3. Crimp the two supplied quick connectors onto the white and black wire.
4. Remove the round locking plastic nut from USB plug before connecting the wires. Black (+) White (-).
5. The wires will then be hooked to the designated terminals on the bottom of the USB plug
6. Drill a 1 1/8" hole in the preferred mounting location. Be sure to clean any sharp edges after drilling.
7. Feed the wires through the mounting hole.
8. If using the round plastic nut to secure plug in place, slide the nut back over the wiring before connecting the wires to powered source.
9. Connect the wires to the identified power source if easier to do so before tightening the plug into place.
10. Tighten plug using either the round plastic nut or mounting plate and two screws, both options supplied.
11. Once connected, hook a USB charging cord into the plug and connect a mobile device/tablet to ensure the plug is operating as you wish (key power working properly if necessary).

NOTE: This plug is not designed to charge two iPads. System damage could occur if this is attempted. System will charge a mobile phone and iPad simultaneously without problem.

4438B Installation Kit

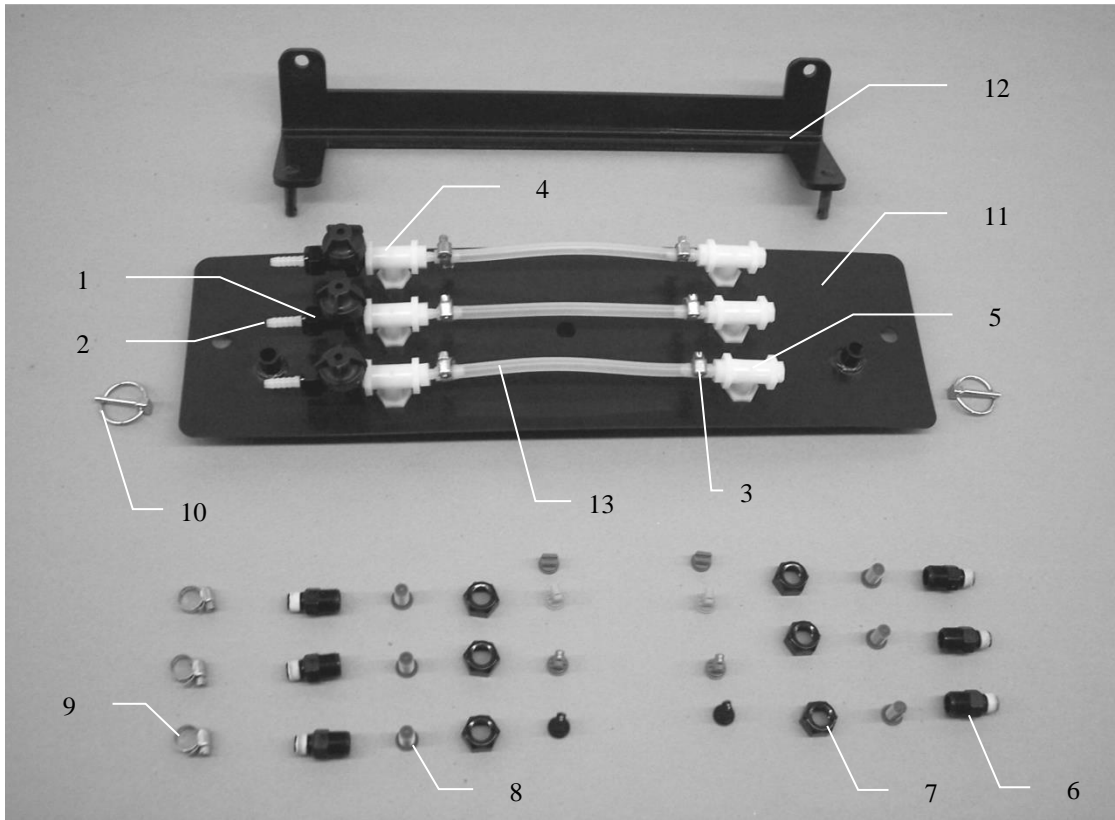

<u>Ref</u>	<u>Description</u>	<u>Part #</u>	<u>Qty</u>	<u>Description</u>	<u>Part #</u>	<u>Qty</u>
1	Check valve	004-1207VB	3	Tip (olive green)	004-800067-PT	2
2	Straight fitting	003-A1414VB	3	Tip (orange)	004-TT11001VP	2
3	Straight fitting	003-A1414	6	Tip (green)	004-TT110015VP	2
4	Tee	003-TT14SQ	3	Tip (blue)	004-TT11003VP	2
5	Street elbow	003-SE14F	3			
6	Nozzle body	004-4722	6			
7	Nozzle cap	004-4723	9			
8	Tip strainer	004-1203-100	6			
9	Hose clamp	003-9002	9			
10	Lynch pin	008-4576	2			
11	Spray shield	001-4438A	1			
12	Mounting bracket	001-4438B	1			
13	Hose – 1/4"	002-9016	3ft			

4439B Installation Kit

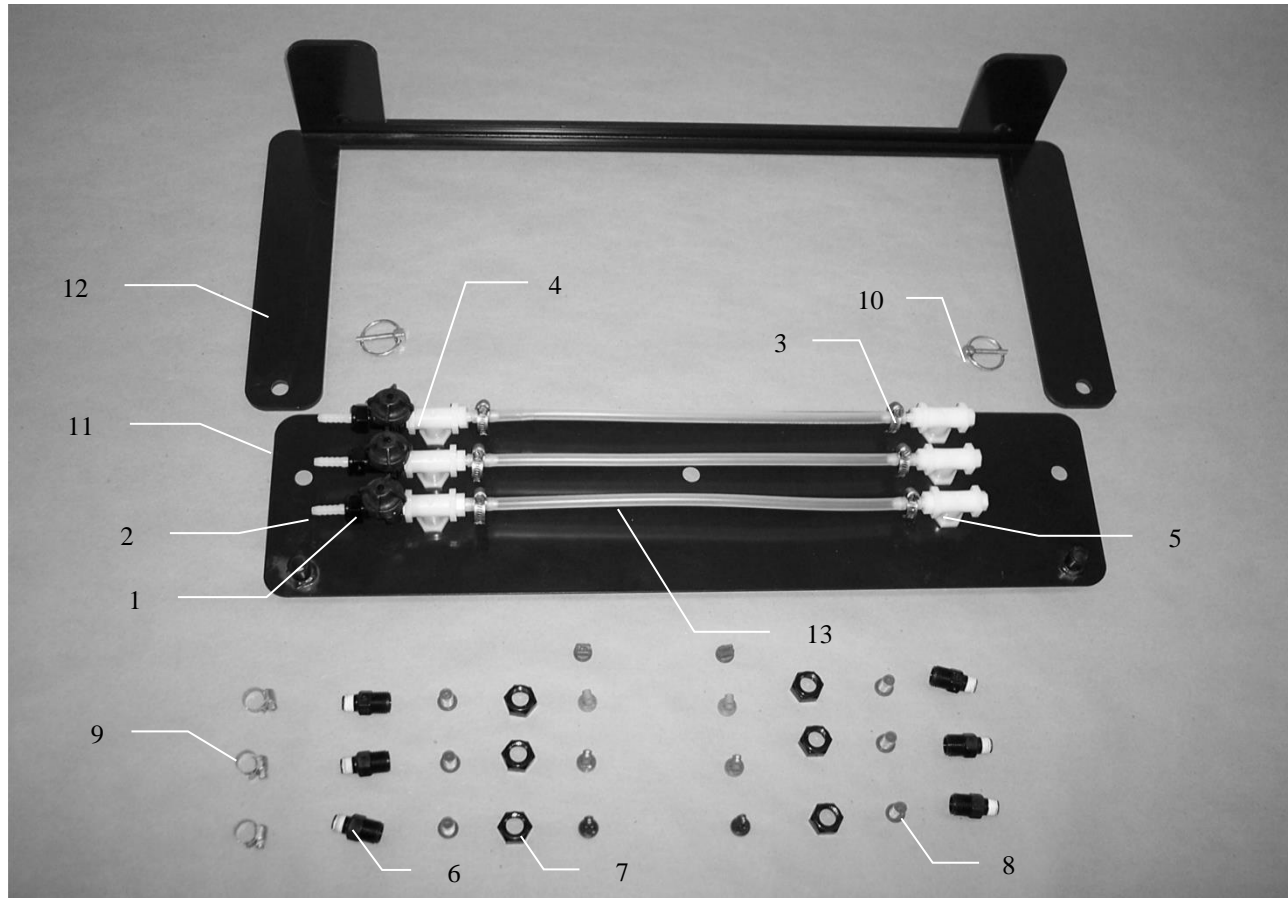

<u>Ref</u>	<u>Description</u>	<u>Part #</u>	<u>Qty</u>	<u>Description</u>	<u>Part #</u>	<u>Qty</u>
1	Check valve	004-1207VB	3	Tip (olive green)	004-800067-PT	2
2	Straight fitting	003-A1414VB	3	Tip (orange)	004-TT11001VP	2
3	Straight fitting	003-A1414	6	Tip (green)	004-TT110015VP	2
4	Tee	003-TT14SQ	3	Tip (blue)	004-TT11003VP	2
5	Street elbow	003-SE14F	3			
6	Nozzle body	004-4722	6			
7	Nozzle cap	004-4723	9			
8	Tip strainer	004-1203-100	6			
9	Hose clamp	003-9002	9			
10	Lynch pin	008-4576	2			
11	Spray shield	001-4439A	1			
12	Mounting bracket	001-4439B	1			
13	Hose – 1/4"	002-9016	3			

4490B Installation Kit

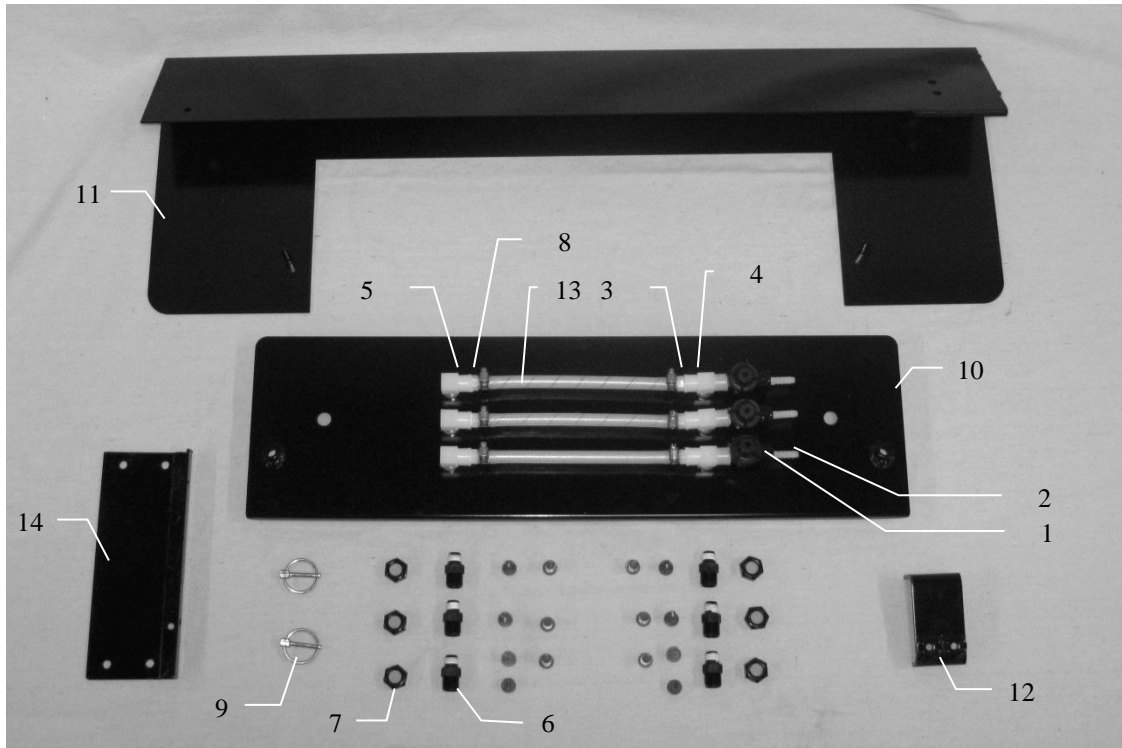

<u>Ref</u>	<u>Description</u>	<u>Part #</u>	<u>Qty</u>	<u>Description</u>	<u>Part #</u>	<u>Qty</u>
1	Check valve	004-1207VB	3	Tip (olive green)	004-800067-PT	2
2	Straight fitting	003-A1414VB	3	Tip (orange)	004-TT11001VP	2
3	Straight fitting	003-A1414	6	Tip (green)	004-TT110015VP	2
4	Tee	003-TT14SQ	3	Tip (blue)	004-TT11003VP	2
5	Street elbow	003-SE14F	3	Tip strainer	004-1203-100	6
6	Nozzle body	004-4722	6			
7	Nozzle cap	004-4723	9			
8	Hose clamp	003-9002	9			
9	Lynch pin	008-4576	2			
10	Spray shield	001-4421	1			
11	Shield holder	001-4421B	1			
12	Backing plate	001-4421A	1			
13	Hose – 1/4"	002-9016	3ft			
14	End of bale mount	001-4648H	1			

4491B Installation Kit

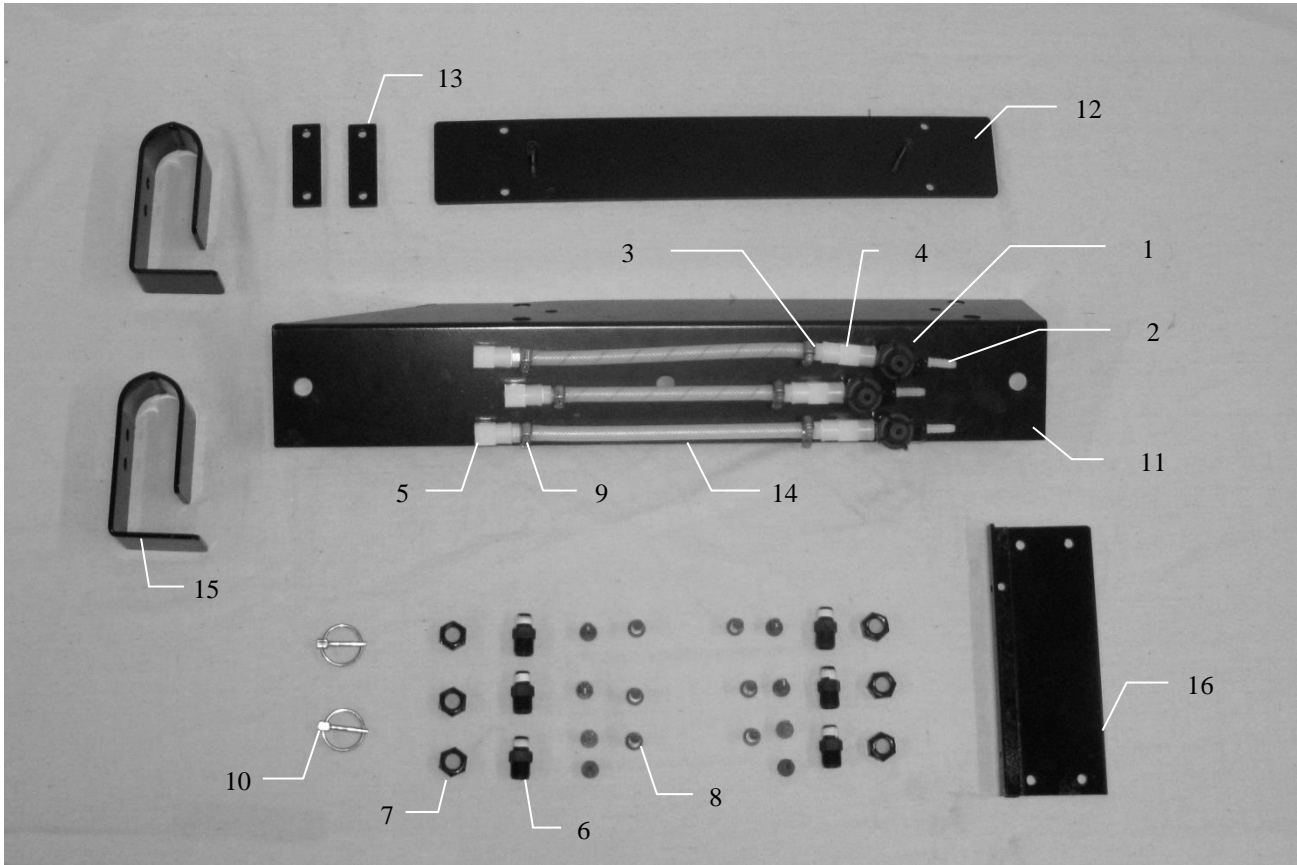

<u>Ref</u>	<u>Description</u>	<u>Part #</u>	<u>Qty</u>	<u>Description</u>	<u>Part #</u>	<u>Qty</u>
1	Check valve	004-1207VB	3	Tip (olive green)	004-800067-PT	2
2	Straight fitting	003-A1414VB	3	Tip (orange)	004-TT11001VP	2
3	Straight fitting	003-A1414	6	Tip (green)	004-TT110015VP	2
4	Tee	003-TT14SQ	3	Tip (blue)	004-TT11003VP	2
5	Street elbow	003-SE14F	3			
6	Nozzle body	004-4722	6			
7	Nozzle cap	004-4723	9			
8	Tip strainer	004-1203-100	6			
9	Hose clamp	003-9002	9			
10	Lynch pin	008-4576	2			
11	Spray shield	001-4422	1			
12	Shield holder	001-4422B	1			
13	Backing plate	001-4422A	2			
14	Hose – 1/4"	002-9016	3ft			
15	Ladder bracket	001-6707H	2			
16	End of bale mount	001-4648H	1			

4492B Installation Kit

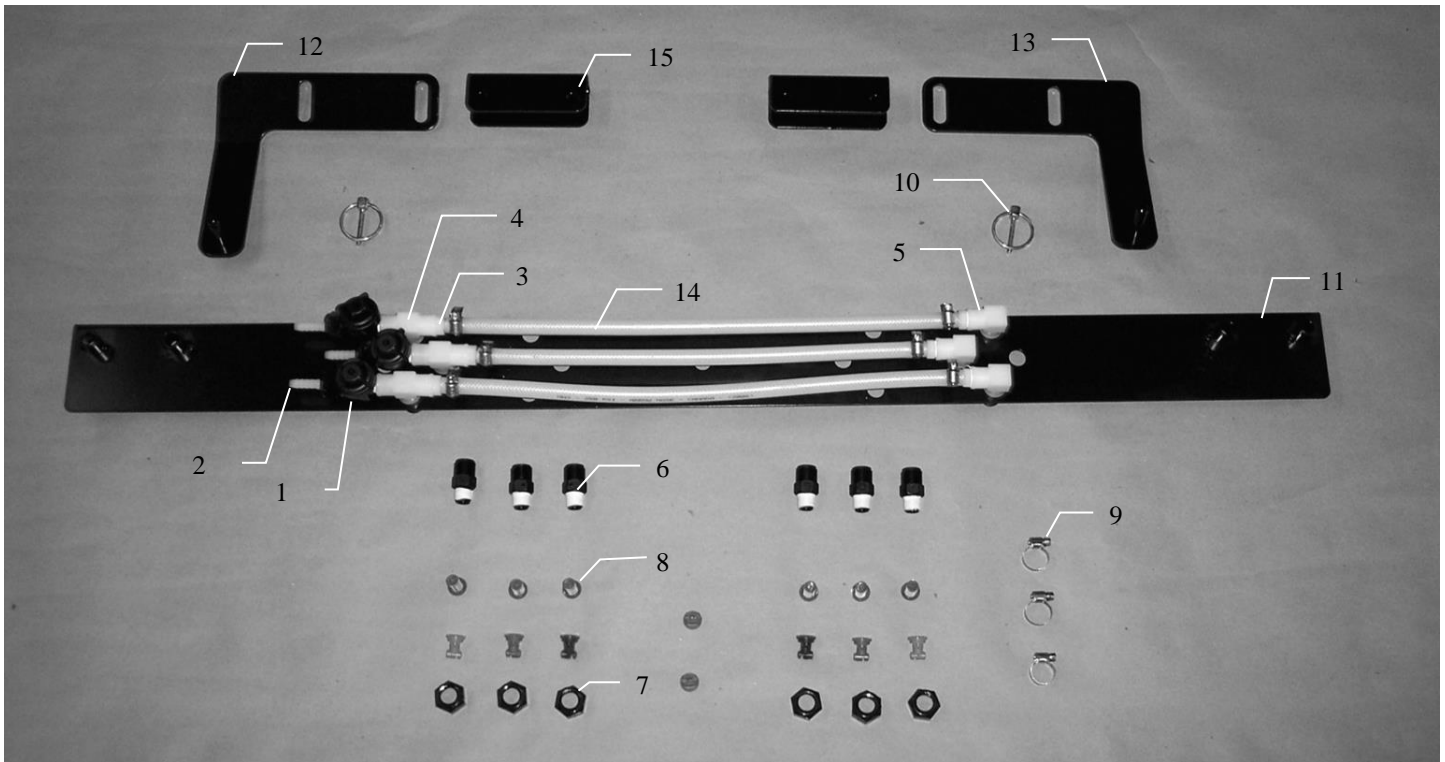

<u>Ref</u>	<u>Description</u>	<u>Part #</u>	<u>Qty</u>	<u>Description</u>	<u>Part #</u>	<u>Qty</u>
1	Check valve	004-1207VB	3	Tip (olive green)	004-800067-PT	2
2	Straight fitting	003-A1414VB	3	Tip (orange)	004-TT11001VP	2
3	Straight fitting	003-A1414	6	Tip (green)	004-TT110015VP	2
4	Tee	003-TT14SQ	3	Tip (blue)	004-TT11003VP	2
5	Street elbow	003-SE14F	3			
6	Nozzle body	004-4722	6			
7	Nozzle cap	004-4723	9			
8	Tip strainer	004-1203-100	6			
9	Hose clamp	003-9002	9			
10	Lynch pin	008-4576	2			
11	Spray shield	001-4811A	1			
12	Left shield holder	001-4436DL	1			
13	Right shield holder	001-4436DR	1			
14	Hose – 1/4"	002-9016	3ft			
15	Spacer	001-4436S	2			

4494B Installation Kit

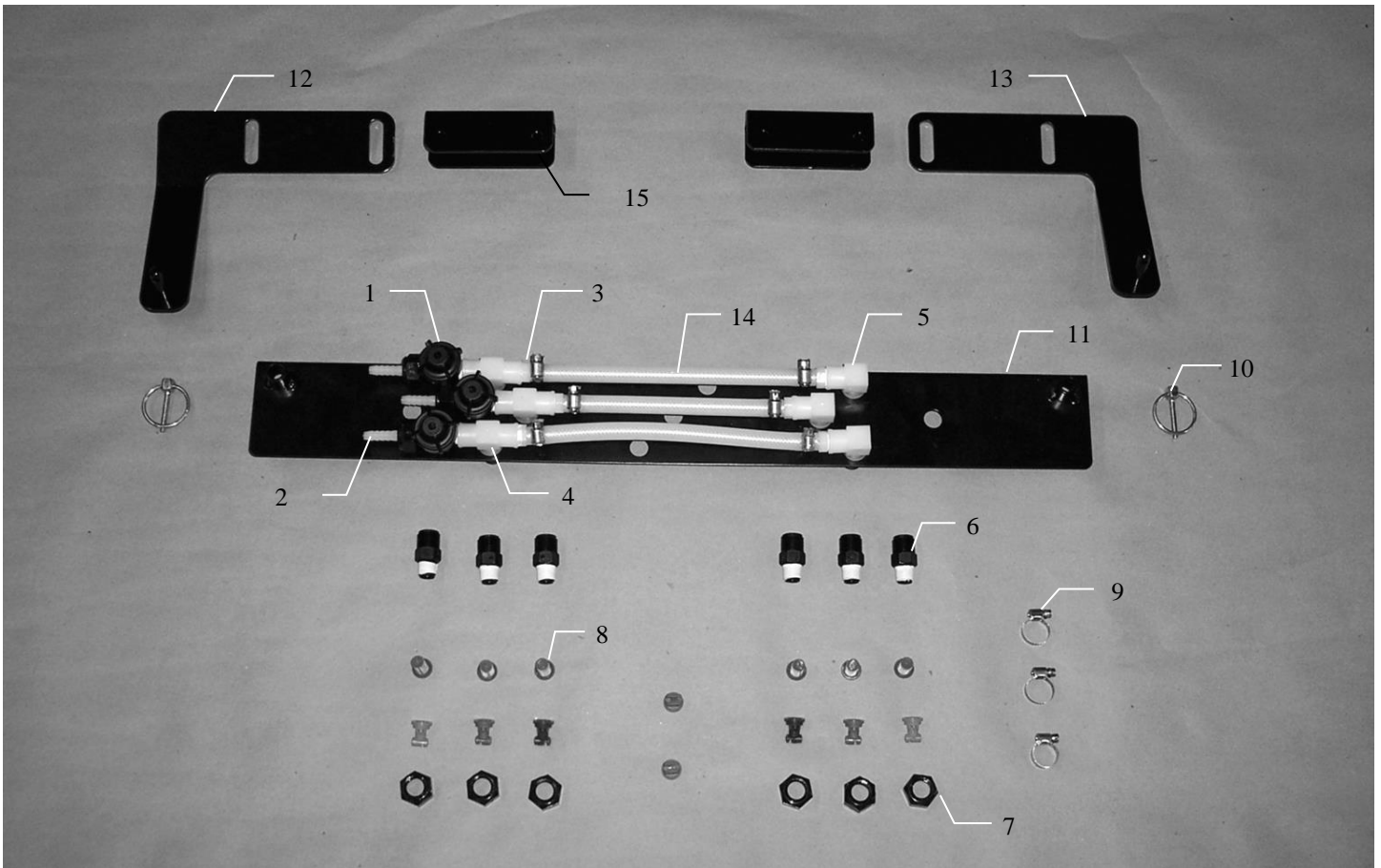

<u>Ref</u>	<u>Description</u>	<u>Part #</u>	<u>Qty</u>	<u>Description</u>	<u>Part #</u>	<u>Qty</u>
1	Check valve	004-1207VB	3	Tip (olive green)	004-800067-PT	2
2	Straight fitting	003-A1414VB	3	Tip (orange)	004-TT11001VP	2
3	Straight fitting	003-A1414	6	Tip (green)	004-TT110015VP	2
4	Tee	003-TT14SQ	3	Tip (blue)	004-TT11003VP	2
5	Street elbow	003-SE14F	3			
6	Nozzle body	004-4722	6			
7	Nozzle cap	004-4723	9			
8	Tip strainer	004-1203-100	6			
9	Hose clamp	003-9002	9			
10	Lynch pin	008-4576	2			
11	Spray shield	001-4810	1			
12	Left shield holder	001-4436DL	1			
13	Right shield holder	001-4436DR	1			
14	Hose – 1/4"	002-9016	3ft			
15	Spacer	001-4436S	2			

4495B & 4528B Installation Kit

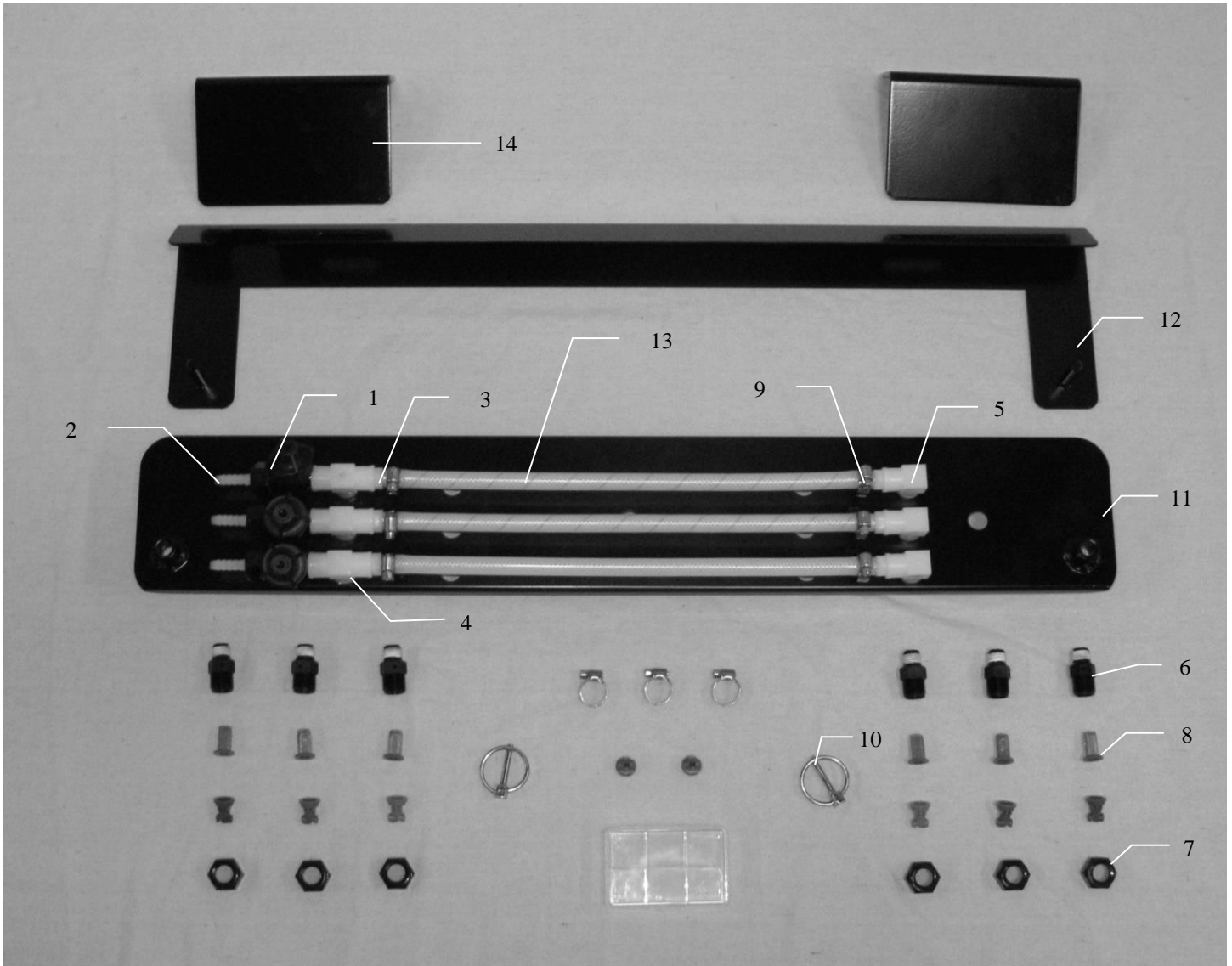

<u>Ref</u>	<u>Description</u>	<u>Part#</u>	<u>Qty</u>	<u>Description</u>	<u>Part#</u>	<u>Qty</u>
1	Check valve	004-1207VB	3	Tip (olive green)	004-800067-PT	2
2	Straight fitting	003-A1414VB	3	Tip (orange)	004-TT11001VP	2
3	Straight fitting	003-A1414	6	Tip (green)	004-TT110015VP	2
4	Tee	003-TT14SQ	3	Tip (blue)	004-TT11003VP	2
5	Street elbow	003-SE14F	3			
6	Nozzle body	004-4722	6			
7	Nozzle cap	004-4723	9			
8	Tip strainer	004-1203-100	6			
9	Hose clamp	003-9002	9			
10	Lynch pin	008-4576	2			
11	Spray shield	001-4431B	1			
12	Shield holder	001-4431	1			
13	Hose – 1/4"	002-9016	3ft			
14	Wind guard stop	001-4431D	2			

4497B & 4529B Installation Kit

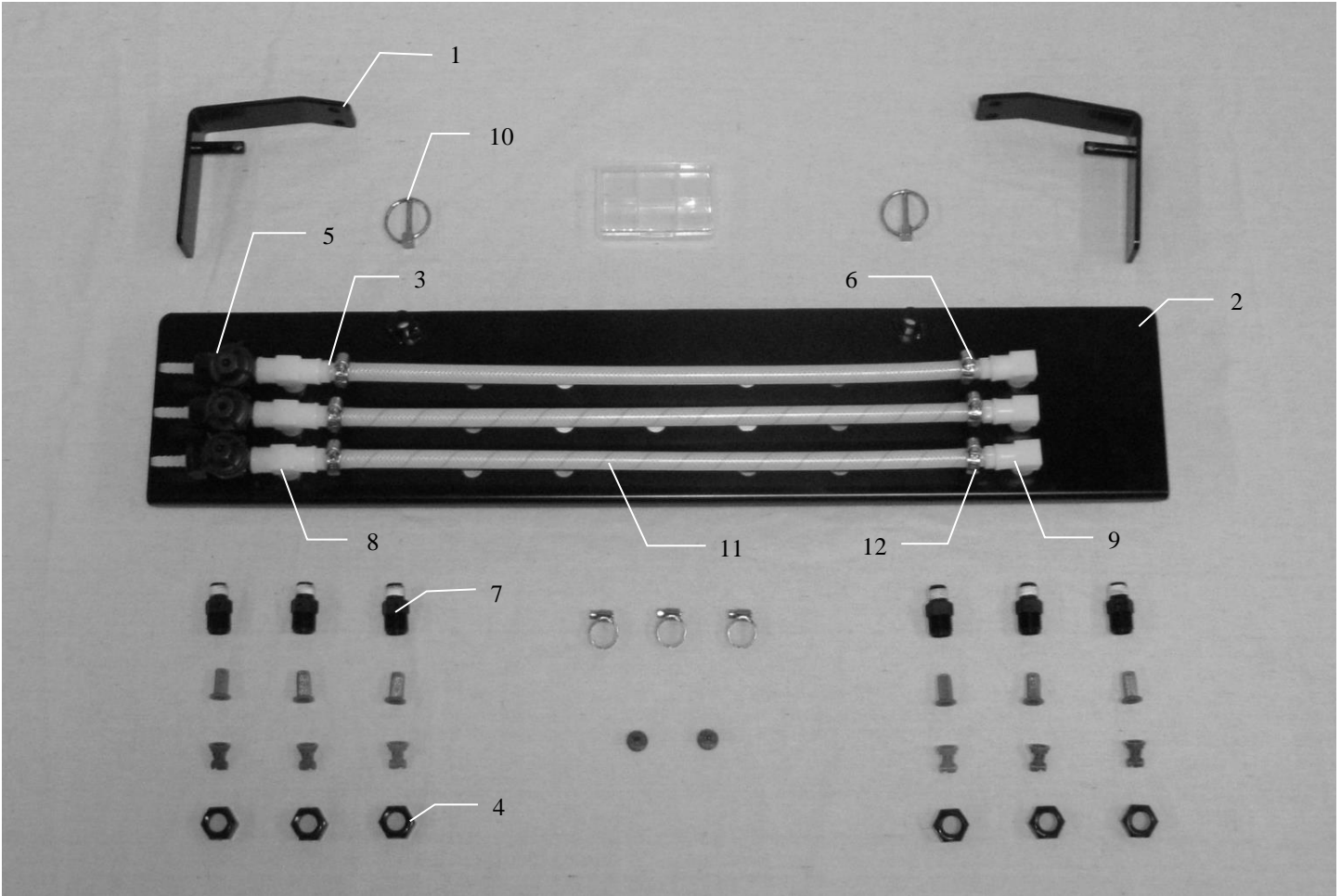

<u>Ref</u>	<u>Description</u>	<u>Part#</u>	<u>Qty</u>	<u>Description</u>	<u>Part#</u>	<u>Qty</u>
1	Mounting Brkt	001-4435E	2	Tip	004-TT11001VP	2
2	Spray Shield	001-4435ES	1	Tip	004-TT110015VP	2
3	Straight Fitting	003-A1414VB	3	Tip	004-TT11003VP	2
4	Nozzle Cap	004-4723	9	Tip	004-800067-PT	2
5	Check Valve	004-1207VB	3	Tip Strainers	004-1203-100	6
6	Straight Fitting	003-A1414	6			
7	Nozzle Body	004-4722	6			
8	Tee	003-TT14SQ	3			
9	Street elbow	003-SE14F	3			
10	Lynch Pin	008-4576	2			
11	Hose	002-9016	4ft			
12	Hose Clamps	003-9002	9			

4498B Installation Kit

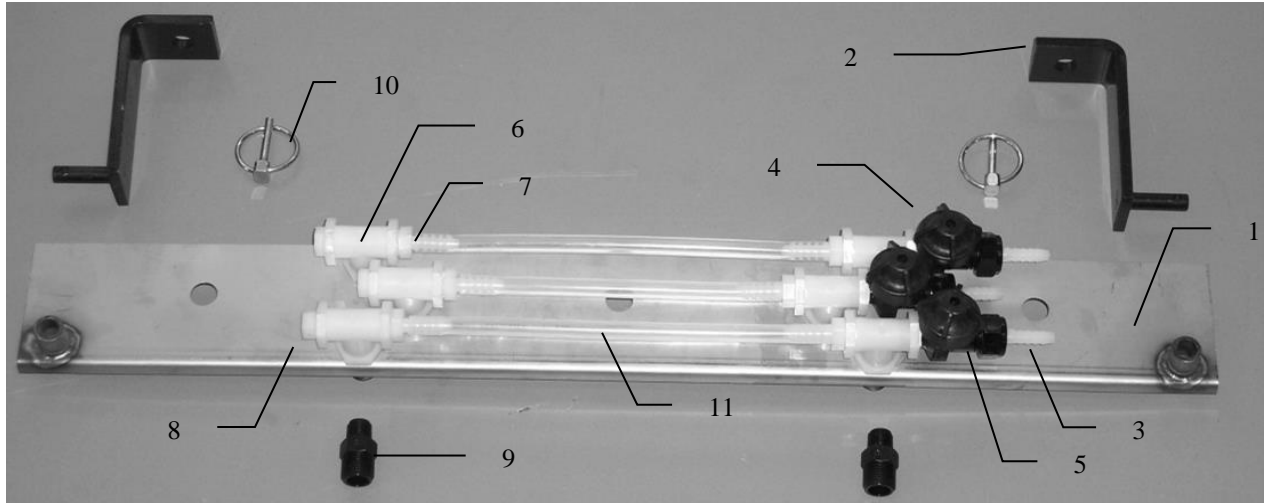

<u>Ref</u>	<u>Description</u>	<u>Part#</u>	<u>Qty</u>	<u>Ref</u>	<u>Description</u>	<u>Part#</u>	<u>Qty</u>
1	Spray Shield	001-4810	1	NP	Tip (orange)	004-TT11001VP	2
2	Shield Holder	001-4810A	2	NP	Tip (green)	004-TT110015VP	2
3	Straight Fitting	003-A1414VB	3	NP	Tip (blue)	004-TT11003VP	2
4	Check Valve	004-1207VB	3	NP	Tip (olive green)	004-800067-PT	2
5	Nozzle Cap	004-4723	9	NP	Tip Strainers	004-1203-100	6
6	Tee	003-TT14	6	NP	Hose Clamps	003-9002	9
7	Straight Fitting	003-A1414	6				
8	Plug	003-F14	3	NP	Not Pictured		
9	Nozzle Body	004-4722	6				
10	Lynch Pin	008-4576	2				
11	Hose	002-9006	4ft				

4499B Installation Kit

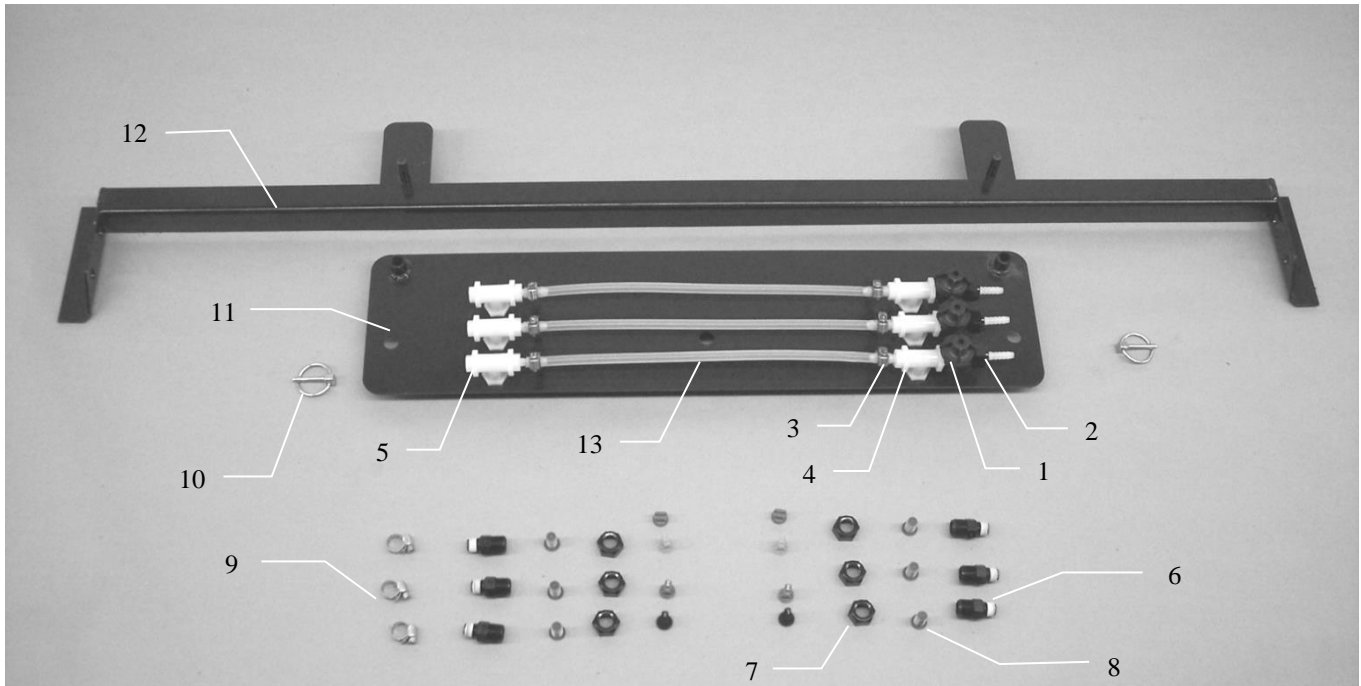

<u>Ref</u>	<u>Description</u>	<u>Part#</u>	<u>Qty</u>	<u>Description</u>	<u>Part#</u>	<u>Qty</u>
1	Check valve	004-1207VB	3	Tip (olive green)	004-800067-PT	2
2	Straight fitting	003-A1414VB	3	Tip (orange)	004-TT11001VP	2
3	Straight fitting	003-A1414	6	Tip (green)	004-TT110015VP	2
4	Tee	003-TT14SQ	3	Tip (blue)	004-TT11003VP	2
5	Street elbow	003-SE14F	3			
6	Nozzle body	004-4722	6			
7	Nozzle cap	004-4723	9			
8	Tip strainer	004-1203-100	6			
9	Hose clamp	003-9002	9			
10	Lynch pin	008-4576	2			
11	Spray shield	001-4439A	1			
12	Shield holder	001-4440	1			
13	Hose – 1/4"	002-9016	3ft			

4500B Installation Kit

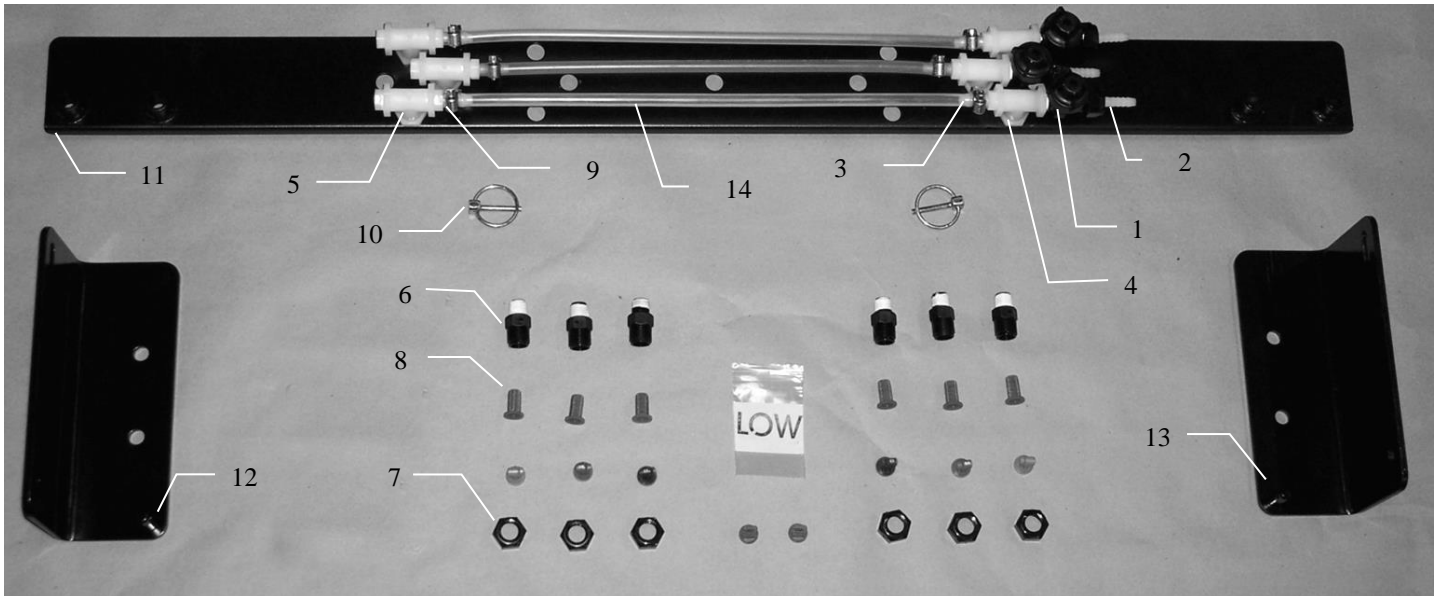

<u>Ref</u>	<u>Description</u>	<u>Part#</u>	<u>Qty</u>	<u>Description</u>	<u>Part#</u>	<u>Qty</u>
1	Check valve	004-1207VB	3	Tip (olive green)	004-800067-PT	2
2	Straight fitting	003-A1414VB	3	Tip (orange)	004-TT11001VP	2
3	Straight fitting	003-A1414	6	Tip (green)	004-TT110015VP	2
4	Tee	003-TT14SQ	3	Tip (blue)	004-TT11003VP	2
5	Street elbow	003-SE14F	3			
6	Nozzle body	004-4722	6			
7	Nozzle cap	004-4723	9			
8	Tip strainer	004-1203-100	6			
9	Hose clamp	003-9002	9			
10	Lynch pin	008-4576	2			
11	Spray shield	001-4811A	1			
12	Left shield holder	001-4436CL	1			
13	Right shield holder	001-4436CR	1			
14	Hose	002-9016	3ft			

4501B Installation Kit

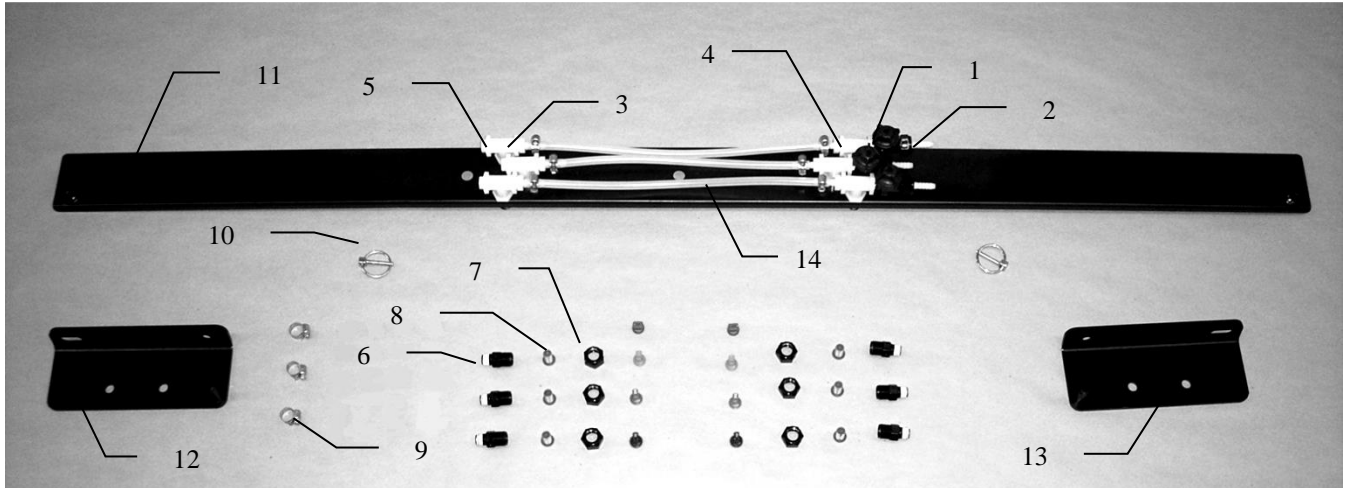

<u>Ref</u>	<u>Description</u>	<u>Part#</u>	<u>Qty</u>	<u>Description</u>	<u>Part#</u>	<u>Qty</u>
1	Check valve	004-1207VB	3	Tip (olive green)	004-800067-PT	2
2	Straight fitting	003-A1414VB	3	Tip (orange)	004-TT11001VP	2
3	Straight fitting	003-A1414	6	Tip (green)	004-TT110015VP	2
4	Tee	003-TT14SQ	3	Tip (blue)	004-TT11003VP	2
5	Street elbow	003-SE14F	3			
6	Nozzle body	004-4722	6			
7	Nozzle cap	004-4723	9			
8	Tip strainer	004-1203-100	6			
9	Hose clamp	003-9002	9			
10	Lynch pin	008-4576	2			
11	Spray shield	001-4436CS	1			
12	Left shield holder	001-4436CL	1			
13	Right shield holder	001-4436CR	1			
14	Hose – 1/4"	002-9016	3ft			

4509B Installation Kit

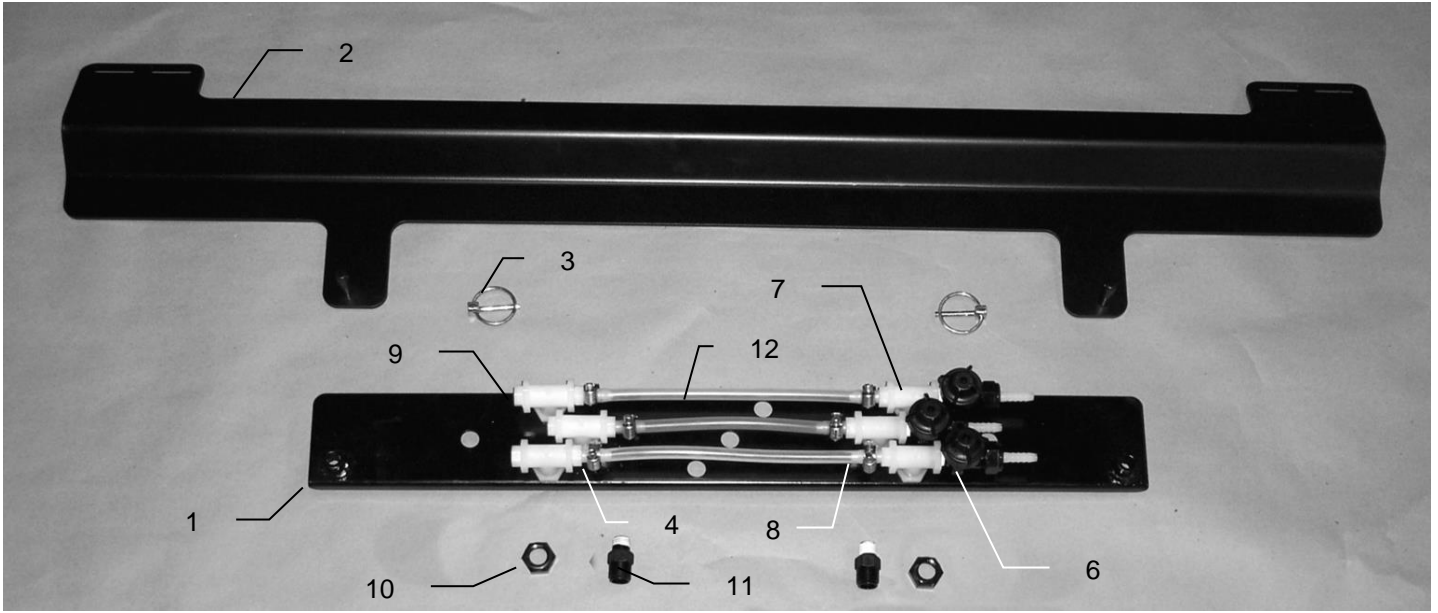

Ref	Description	Part #	Qty	Description	Part #	Qty
1	Spray Shield	001-4810	1	Tip (blue)	004-TT11001VP	2
2	Shield holder	001-4440A	1	Tip (green)	004-TT110015VP	2
3	Lynch Pins	008-4576	2	Tip (orange)	004-TT11003VP	2
4	Hose Clamps	003-9002	9	Tip (olive green)	004-800067-PT	2
5	Straight Fitting	003-A1414VB	3	Tip Strainers	004-1203-100	6
6	Check Valve	004-1207VB	3			
7	Tee	003-TT14SQ	3			
8	Straight Fitting	003-A1414	6			
9	90 degree elbow	003-SE14F	3			
10	Nozzle Cap	004-4723	9			
11	Nozzle Body	004-4722	6			
12	Hose	002-9016	3ft			

4510B Installation Kit

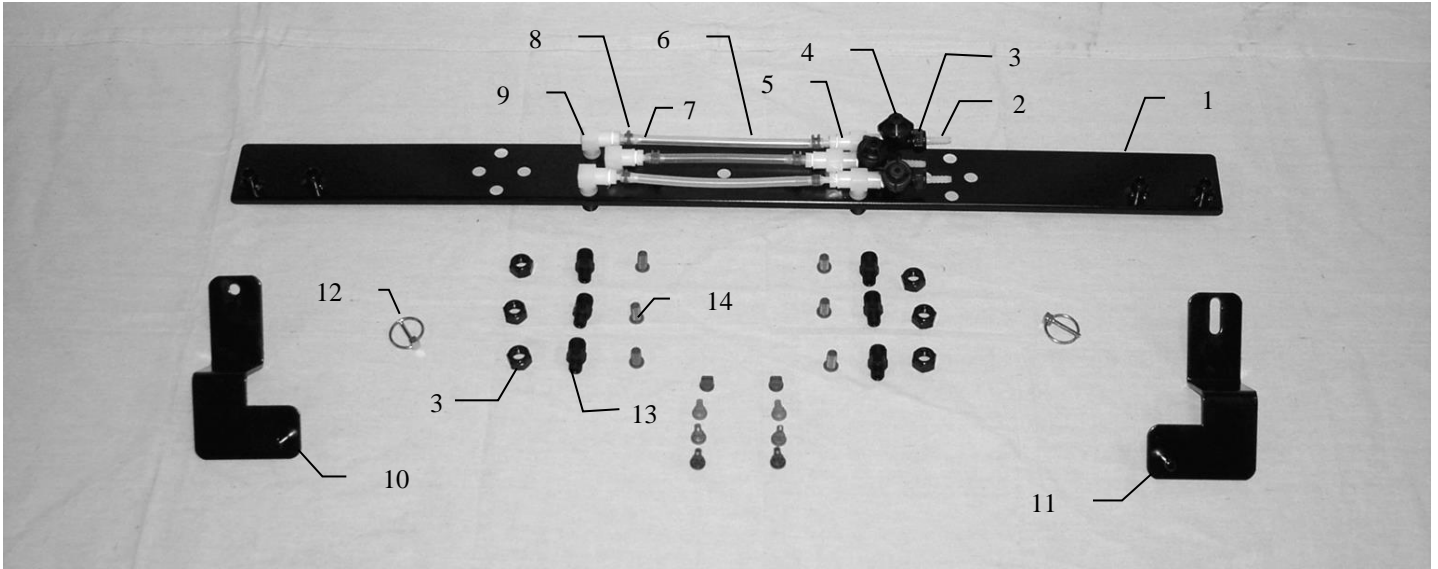

<u>Ref</u>	<u>Description</u>	<u>Part #</u>	<u>Qty</u>	<u>Description</u>	<u>Part #</u>	<u>Qty</u>
1	Spray shield	001-4811A	1	Tip (orange)	004-TT11001VP	2
2	Straight fitting	003-A1414VB	3	Tip (green)	004-TT110015VP	2
3	Nozzle cap	004-4723	9	Tip (blue)	004-TT11003VP	2
4	Check valve	003-1207VB	3	Tip (olive green)	004-800067-PT	2
5	Tee	003-TT14SQ	3			
6	Hose	002-9016	3ft			
7	Straight fitting	003-A1414	6			
8	Hose clamp	003-9002	9			
9	Elbow	003-SE14F	3			
10	Shield hanger	001-4704A	1			
11	Shield hanger	001-4704B	1			
12	Lynch pin	008-4576	2			
13	Nozzle body	004-4722	6			
14	Tip Strainers	004-1203-100	6			

4511B Installation Kit

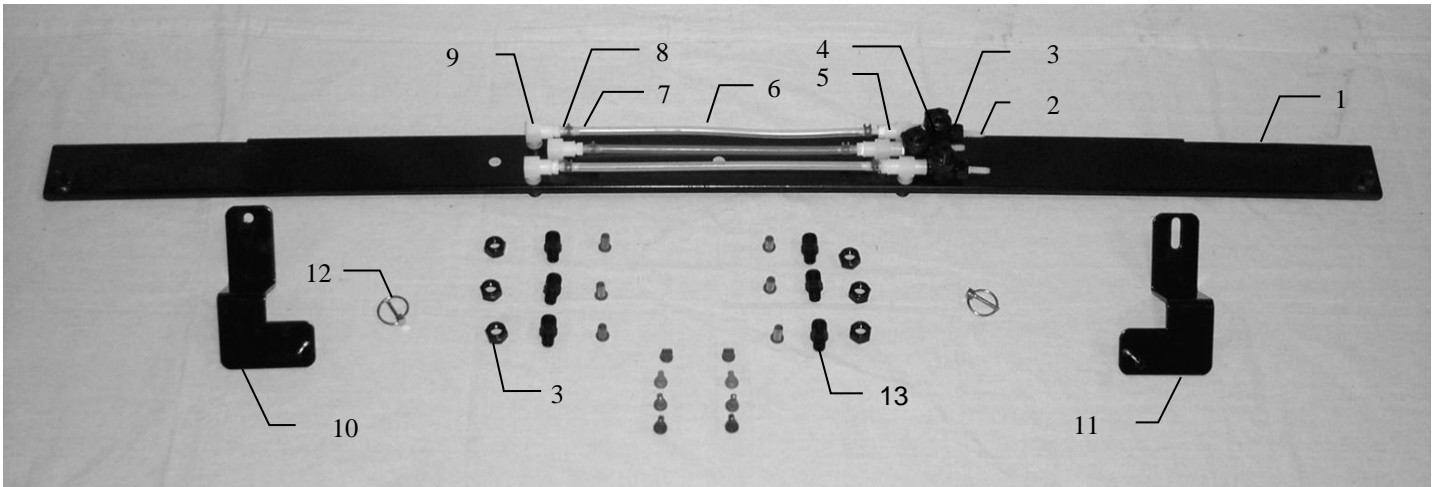

<u>Ref</u>	<u>Description</u>	<u>Part #</u>	<u>Qty</u>	<u>Description</u>	<u>Part #</u>	<u>Qty</u>
1	Spray shield	001-4704C	1	Tip (orange)	004-TT11001VP	2
2	Straight fitting	003-A1414VB	3	Tip (green)	004-TT110015VP	2
3	Nozzle cap	004-4723	9	Tip (blue)	004-TT11003VP	2
4	Check valve	003-1207VB	3	Tip (olive green)	004-800067-PT	2
5	Tee	003-TT14SQ	3	Tip Strainers	004-1203-100	6
6	Hose	002-9016	3ft			
7	Straight fitting	003-A1414	6			
8	Hose clamp	003-9002	9			
9	Elbow	003-SE14F	3			
10	Shield hanger	001-4704A	1			
11	Shield hanger	001-4704B	1			
12	Lynch pin	008-4576	2			
13	Nozzle body	004-4722	6			

4514B Installation Kit

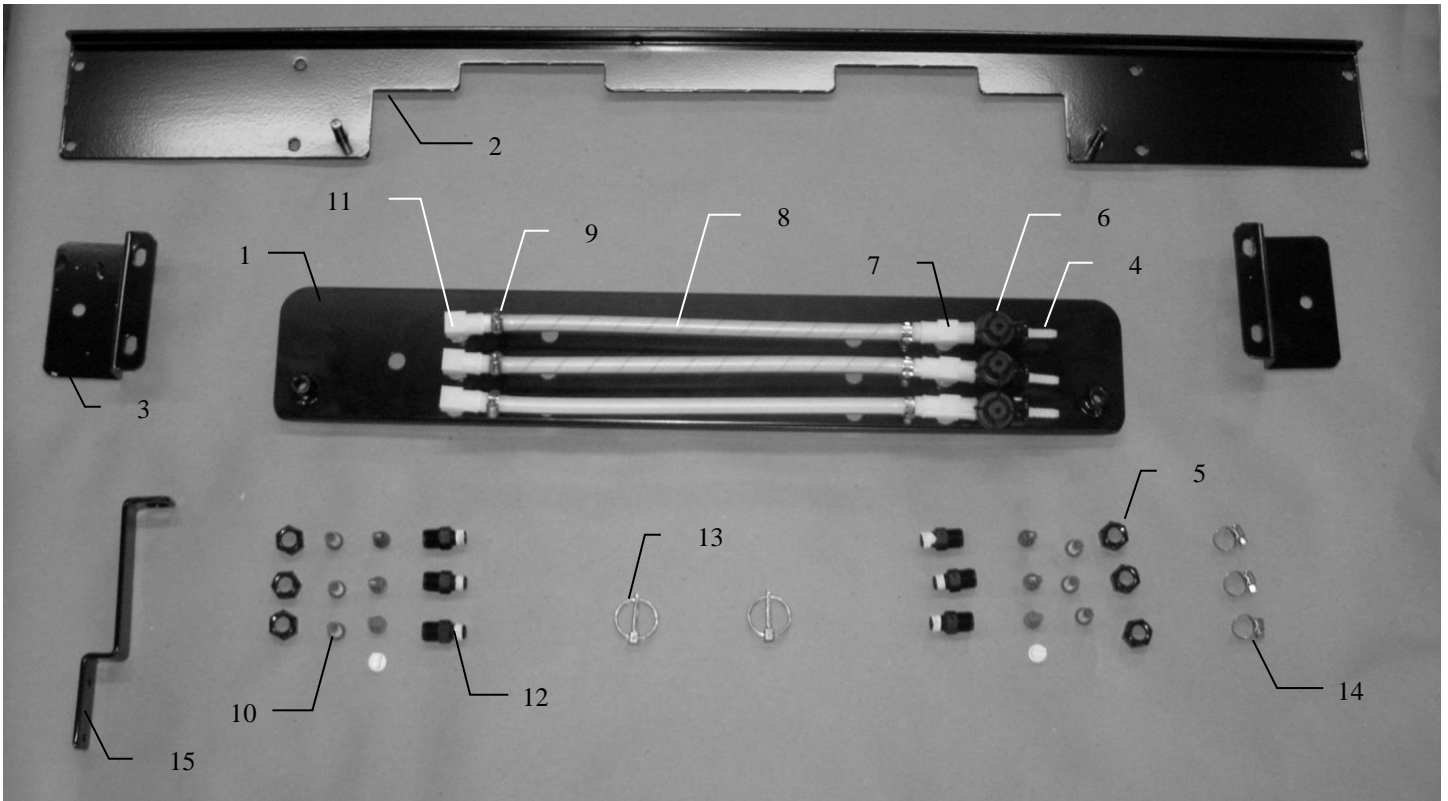

<u>Ref</u>	<u>Description</u>	<u>Part #</u>	<u>Qty</u>	<u>Description</u>	<u>Part #</u>	<u>Qty</u>
1	Spray shield	001-4431B	1	Tip (orange)	004-TT11001VP	2
2	Shield holder	001-4431KA	1	Tip (green)	004-TT110015VP	2
3	Mounting brackets	001-4431KB	2	Tip (blue)	003-TT11003VP	2
4	Straight fitting	003-A1414VB	3	Tip (olive green)	004-800067-PT	2
5	Nozzle cap	003-4723	9			
6	Check valve	004-1207VB	3			
7	Tee	003-TT14SQ	3			
8	Hose	002-9016	6			
9	Straight fitting	003-A1414	6			
10	Tip Strainers	004-1203-100	6			
11	Elbow	003-SE14F	3			
12	Nozzle body	004-4722	6			
13	Lynch pin	008-4576	2			
14	Hose clamp	002-9002	9			
15	End of bale sensor mount	001-4648K	1			
NP	End of bale sensor mount (Krone 12130 only)	001-4648K2	1			
NP	Not pictured					

4515B Installation Kit

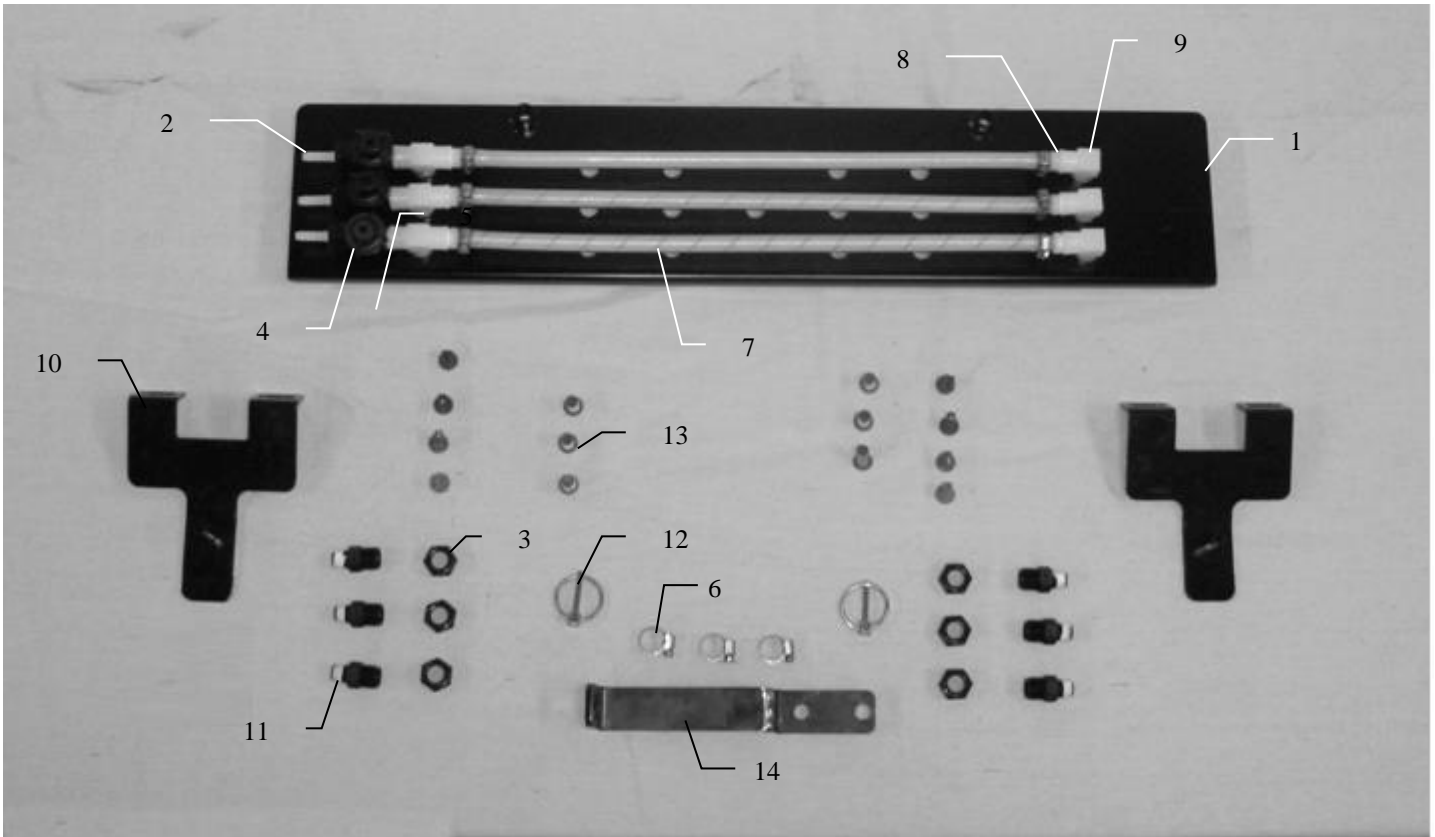

<u>Ref</u>	<u>Description</u>	<u>Part #</u>	<u>Qty</u>	<u>Description</u>	<u>Part #</u>	<u>Qty</u>
1	Spray shield	001-4435AS	1	Tip (orange)	004-TT11001VP	2
2	Straight fitting	003-A1414VB	3	Tip (green)	004-TT110015VP	2
3	Nozzle cap	004-4723	9	Tip (blue)	004-TT11003VP	2
4	Check valve	004-1207VB	3	Tip (olive green)	004-800067-PT	2
5	Tee	003-TT14SQ	3			
6	Hose clamp	003-9002	9			
7	Hose	002-9016	4ft			
8	Straight fitting	003-A1414	6			
9	Elbow	003-SE14F	3			
10	Shield holder	001-4435KS	2			
11	Nozzle body	004-4722	6			
12	Lynch pin	008-4576	2			
13	Tip strainers	004-1203-100	6			
14	End of bale sensor mount	001-4648K	1			
NP	End of bale sensor mount (Krone 12130 only)	001-4648K2	1			
NP	Not pictured					

4525B Installation Kit

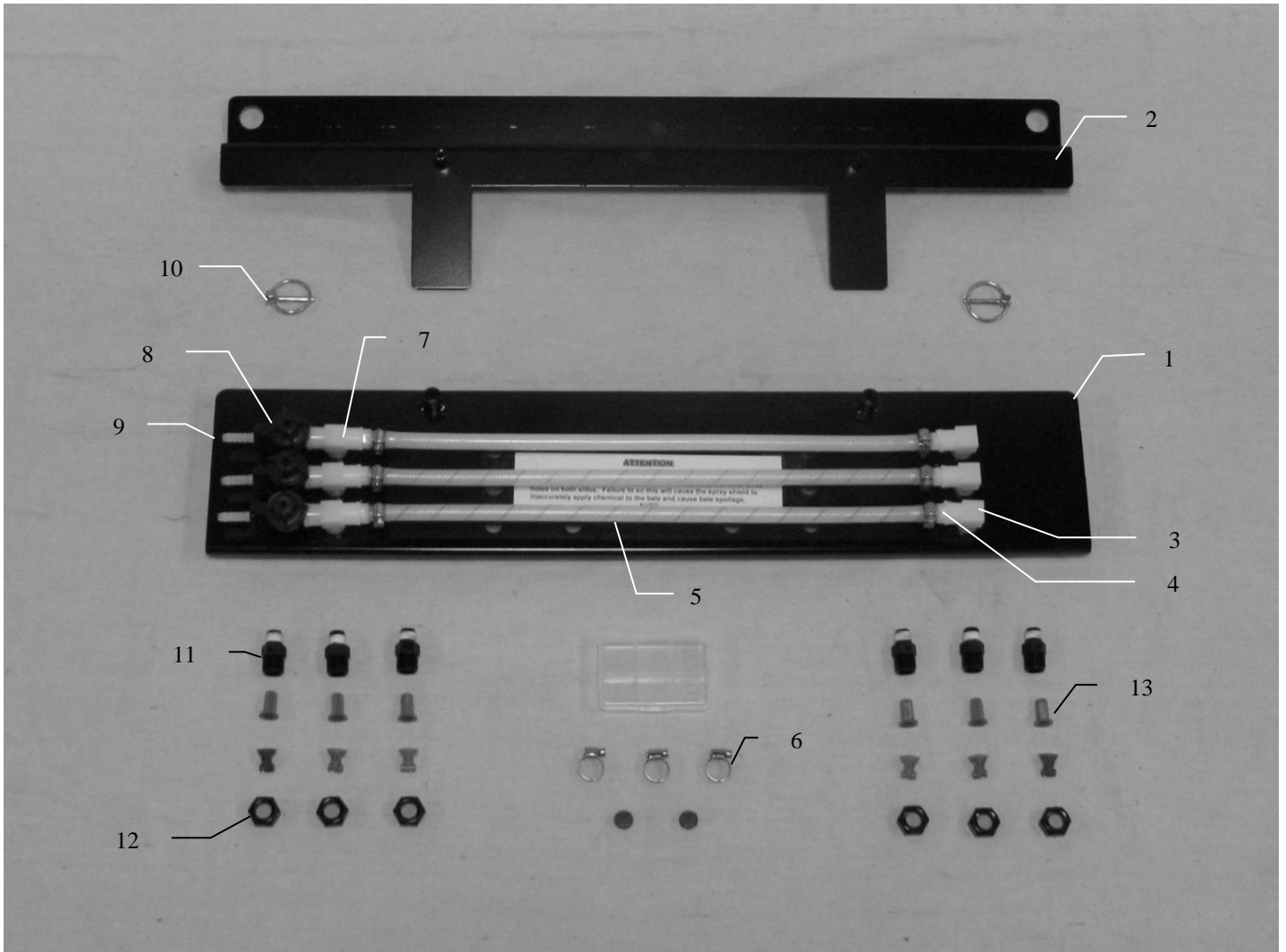

<u>Ref</u>	<u>Description</u>	<u>Part #</u>	<u>Qty</u>	<u>Description</u>	<u>Part #</u>	<u>Qty</u>
1	Spray shield	001-4435ES	1	Tip (olive green)	004-800067-PT	2
2	Shield holder	001-4435EK	1	Tip (orange)	004-TT11001VP	2
3	Elbow	003-SE14SQ	3	Tip (green)	004-TT110015VP	2
4	Straight fitting	003-A1414	6	Tip (blue)	004-TT11003VP	2
5	Hose	002-9016	6ft			
6	Hose clamp	003-9002	9			
7	Tee	003-TT14SQ	3			
8	Check valve	004-1207VB	3			
9	Straight fitting	003-A1414VB	3			
10	Lynch pin	008-4576	2			
11	Nozzle body	004-4722	6			
12	Nozzle cap	004-4723	9			
13	Tip strainer	004-1203-100	6			

4525JB Installation Kit

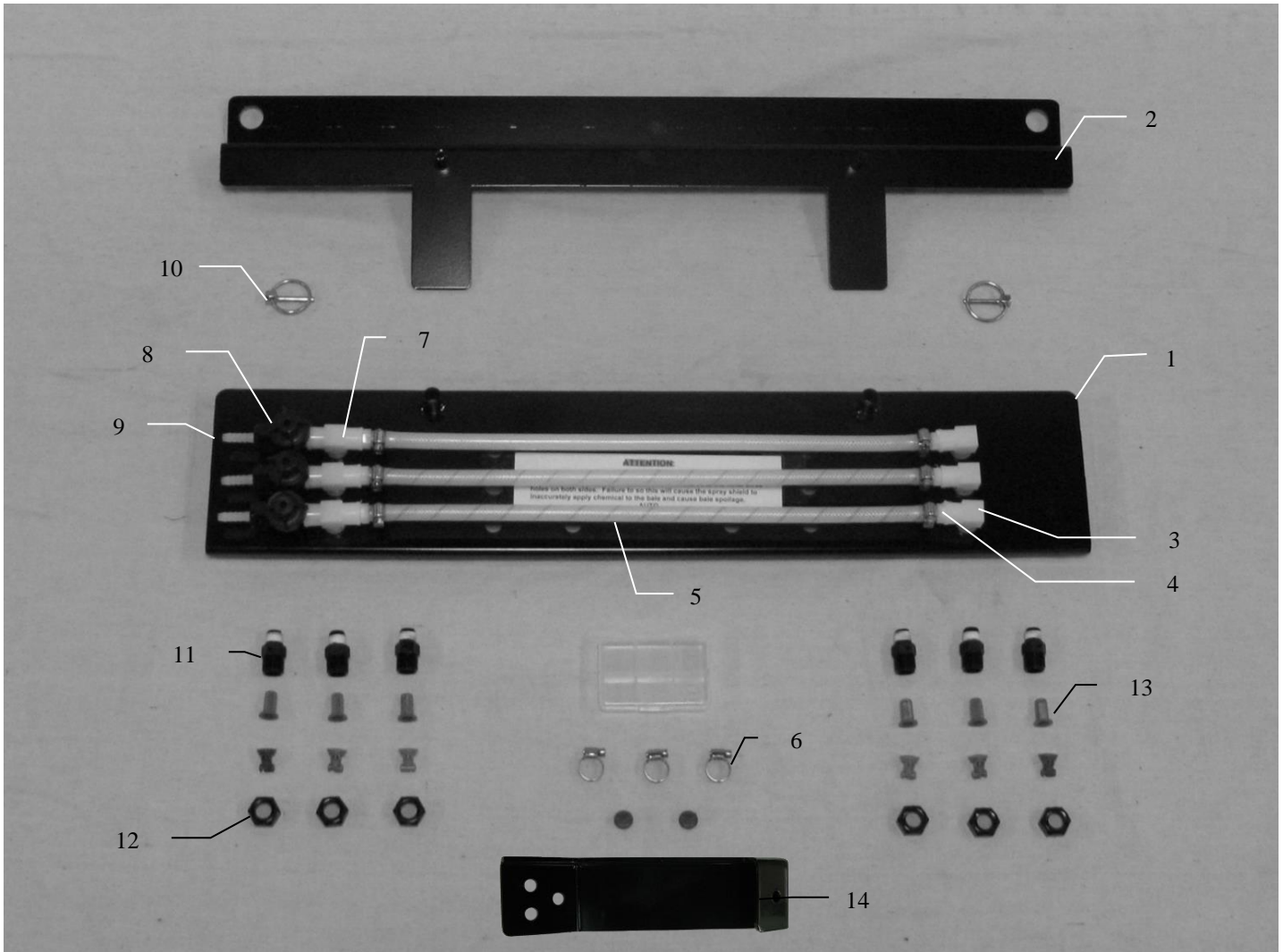

<u>Ref</u>	<u>Description</u>	<u>Part #</u>	<u>Qty</u>	<u>Description</u>	<u>Part #</u>	<u>Qty</u>
1	Spray shield	001-4435ES	1	Tip (olive green)	004-800067-PT	2
2	Shield holder	001-4435EJ	1	Tip (orange)	004-TT11001VP	2
3	Elbow	003-SE14F	3	Tip (green)	004-TT110015VP	2
4	Straight fitting	003-A1414	6	Tip (blue)	004-TT11003VP	2
5	Hose	002-9016	6ft			
6	Hose clamp	003-9002	9			
7	Tee	003-TT14SQ	3			
8	Check valve	004-1207VB	3			
9	Straight fitting	003-A1414VB	3			
10	Lynch pin	008-4576	2			
11	Nozzle body	004-4722	6			
12	Nozzle cap	004-4723	9			
13	Tip strainer	004-1203-100	6			
14	Pump Plate Holder	001-6707JX	2			

(Not Included w/ Install Kit)

4537B Installation Kit

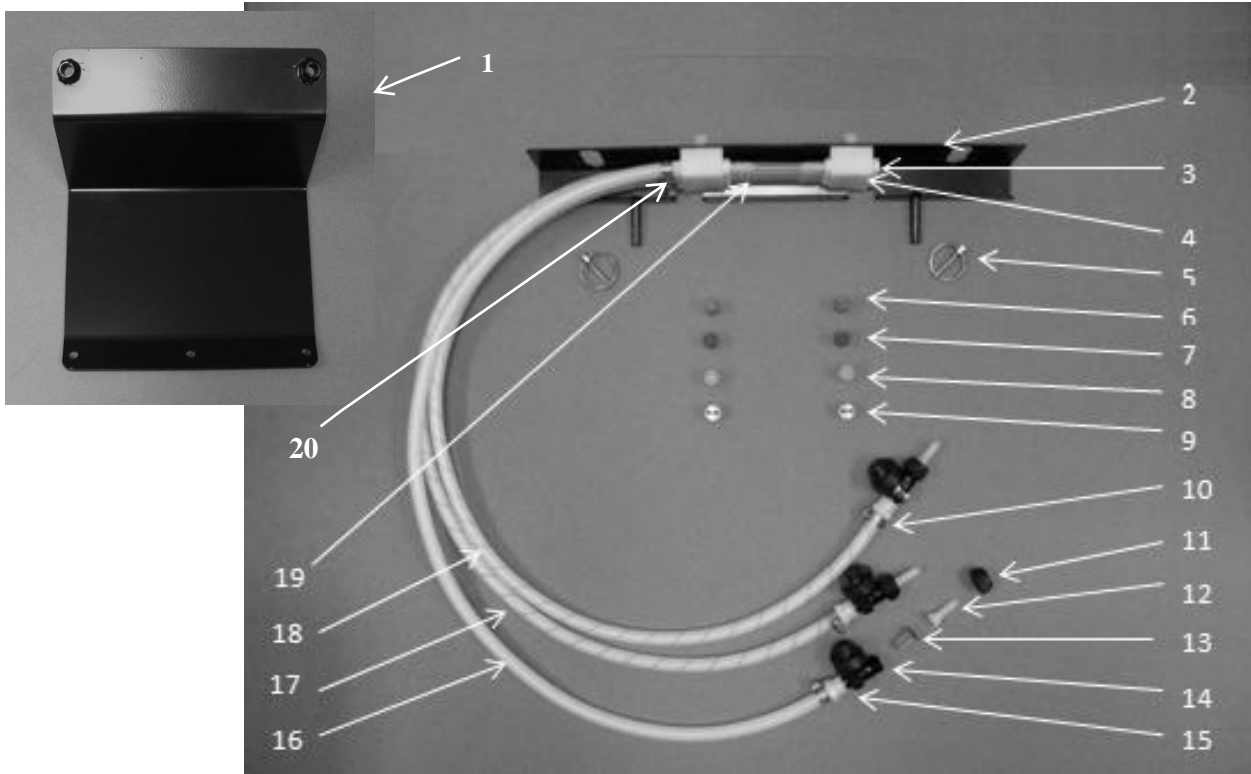

<u>Ref</u>	<u>Description</u>	<u>Part Number</u>	<u>Qty</u>	<u>Ref</u>	<u>Description</u>	<u>Part Number</u>	<u>Qty</u>
1	Holder	001-4435L	1	11	Cap	004-4723	3
2	Shield	001-4435NSX	1	12	Fitting	003-A1414VB	3
3	Fitting	003-F14	3	13	Strainer	004-1203-100	3
4	Manifold Block	001-4435NSB	2	14	Check Valve	004-1207VB	3
5	Lynch Pin	008-4576	2	15	Fitting	003-A1414F	3
6	Tip-Red	004-T8003-PT	2	16	Clear Tubing-1/4"	002-9016	3ft
7	Tip-Brown	004-T80015-PT	2	17	Blue Stripe Tubing	002-9016B	3ft
8	Tip-Pink	004-T8001-PT	2	18	Green Stripe Tubing	002-9016G	3ft
9	Tip-Stainless	004-T800067-SS	2	19	EVA-1/4"	002-9006	3ft
10	Hose Clamp	003-9002	15	20	Fitting	003-A1414	9
				NP	Mini Plano Box	008-9001	1

4539B Installation Kit

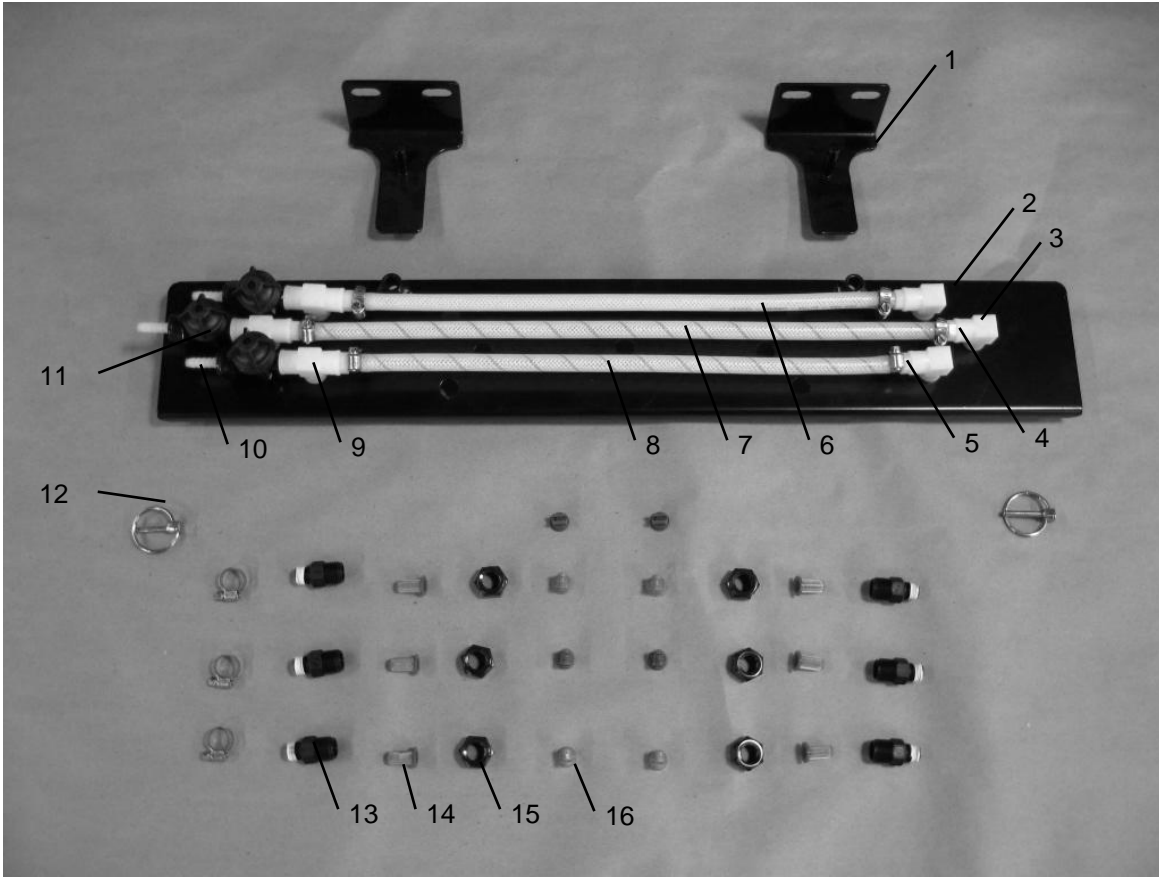

<u>Ref</u>	<u>Description</u>	<u>Part #</u>	<u>Qty</u>	<u>Ref</u>	<u>Description</u>	<u>Part #</u>	<u>Qty</u>
1	Shield Holder	001-4435KX	2	16	Nozzle Tips		
2	Spray Shield	001-4435AS	1		Tip (olive green)	004-800067-PT	2
3	Street Elbow	003-SE14F	3		Tip (orange)	004-TT11001VP	2
4	Fitting	003-A1414	6		Tip (green)	004-TT110015VP	2
5	Hose clamp	003-9002	9		Tip (blue)	004-TT11003VP	2
6	Hose-clear	002-9016	2ft	NP	Plano Box	008-9001	1
7	Hose-blue	002-9016B	2ft	NP	EOB Bracket	001-4648K2	1
8	Hose-green	002-9016G	2ft				
9	Tee	003-TT14SQ	3				
10	Fitting	003-A1414VB	3				
11	Check Valve	004-1207VB	3				
12	Lynch Pin	008-4576	2				
13	Nozzle Body	004-4722	6				
14	Strainer	004-1203-100	6				
15	Nozzle cap	004-4723	9				

4540B Installation Kit

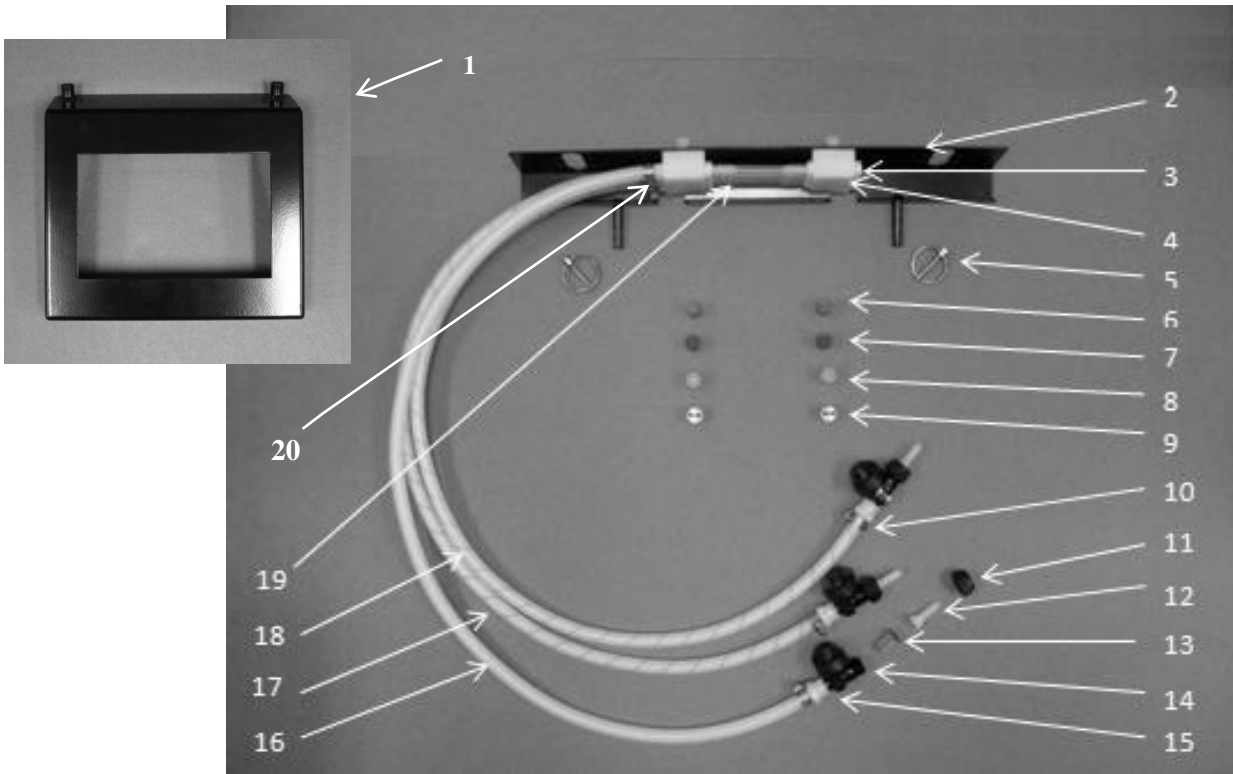

<u>Ref</u>	<u>Description</u>	<u>Part Number</u>	<u>Qty</u>	<u>Ref</u>	<u>Description</u>	<u>Part Number</u>	<u>Qty</u>
1	Holder	001-4435KC	1	11	Cap	004-4723	3
2	Shield	001-4435NSX	1	12	Fitting	003-A1414VB	3
3	Fitting	003-F14	3	13	Strainer	004-1203-100	3
4	Manifold Block	001-4435NSB	2	14	Check Valve	004-1207VB	3
5	Lynch Pin	008-4576	2	15	Fitting	003-A1414F	3
6	Tip-Red	004-T8003-PT	2	16	Clear Tubing-1/4"	002-9016	3ft
7	Tip-Brown	004-T80015-PT	2	17	Blue Stripe Tubing	002-9016B	3ft
8	Tip-Pink	004-T8001-PT	2	18	Green Stripe Tubing	002-9016G	3ft
9	Tip-Stainless	004-T800067-SS	2	19	EVA-1/4"	002-9006	1ft
10	Hose Clamp	003-9002	15	20	Fitting	003-A1414	9
				NP	Mini Plano Box	008-9001	1
				NP	EOB Bracket	001-4648K	1

4540BX Installation Kit

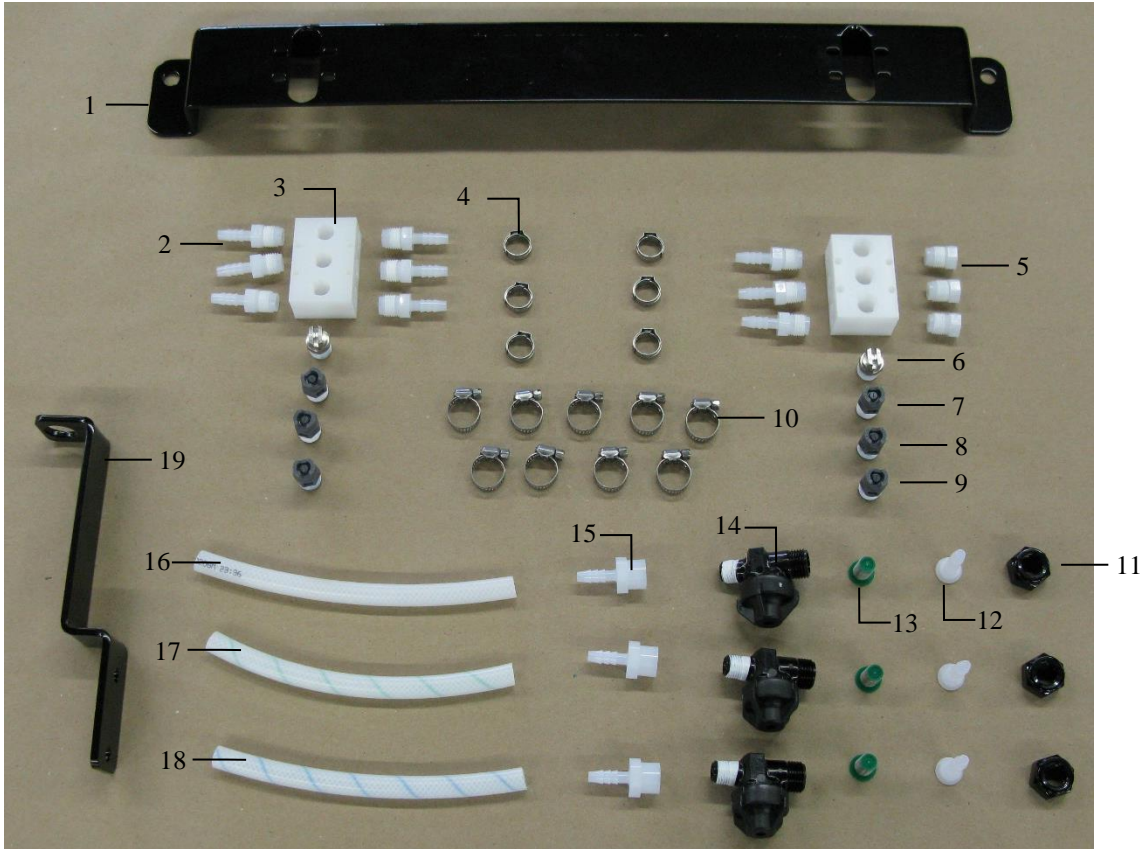

<u>Ref</u>	<u>Description</u>	<u>Part Number</u>	<u>Qty</u>	<u>Ref</u>	<u>Description</u>	<u>Part Number</u>	<u>Qty</u>
1	Tip Holder	001-4435NKS	1	11	Cap	004-4723	3
2	1/4" x 1/4" Straight	003-A1414	9	12	1/4" x1/4" Straight	003-A1414VB	3
3	Manifold Block	001-4435NSB	2	13	Tip Strainer	004-1203-100	3
4	Otiker Clamp	003-9008	6	14	Check Valve	004-1207VB	3
5	Plug Fitting	003-F14	3	15	1/4" Fitting	003-A1414F	3
6	Tip	004-T800067-SS	2	16	Hose – Clear	002-9016	4
7	Tip	004-T8001-PT	2	17	Hose – Green	002-9016G	4
8	Tip	004-T80015-PT	2	18	Hose – Blue	002-9016B	4
9	Tip	004-T8003-PT	2	19	EOB Holder	001-4648K	1
10	Hose Clamp	003-9002	9				

4541B Installation Kit

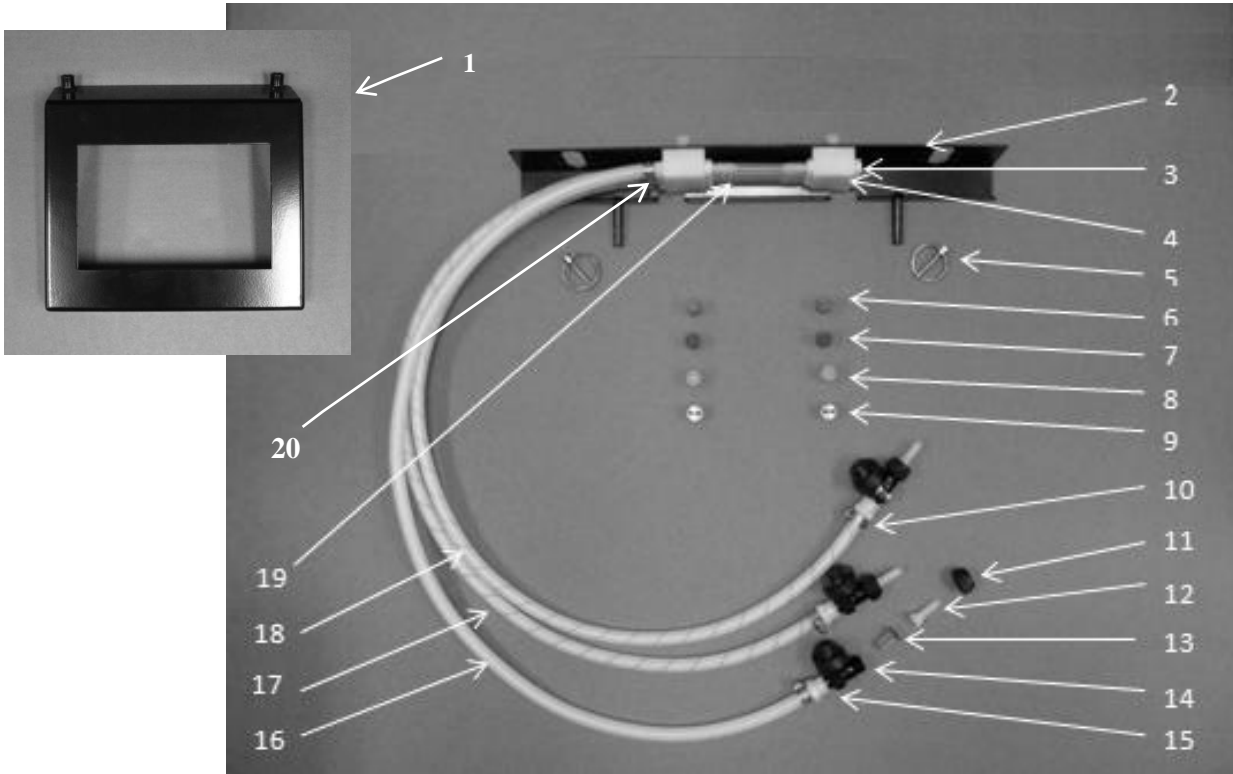

<u>Ref</u>	<u>Description</u>	<u>Part Number</u>	<u>Qty</u>	<u>Ref</u>	<u>Description</u>	<u>Part Number</u>	<u>Qty</u>
1	Holder	001-4435KC	1	11	Cap	004-4723	3
2	Shield	001-4435NSX	1	12	Fitting	003-A1414VB	3
3	Fitting	003-F14	3	13	Strainer	004-1203-100	3
4	Manifold Block	001-4435NSB	2	14	Check Valve	004-1207VB	3
5	Lynch Pin	008-4576	2	15	Fitting	003-A1414F	3
6	Tip-Red	004-T8003-PT	2	16	Clear Tubing-1/4"	002-9016	4ft
7	Tip-Brown	004-T80015-PT	2	17	Blue Stripe Tubing	002-9016B	4ft
8	Tip-Pink	004-T8001-PT	2	18	Green Stripe Tubing	002-9016G	4ft
9	Tip-Stainless	004-T800067-SS	2	19	EVA-1/4"	002-9006	1ft
10	Hose Clamp	003-9002	15	20	Fitting	003-A1414	9
				NP	Mini Plano Box	008-9001	1
				NP	EOB Bracket	001-4648K	1

4541BX Installation Kit

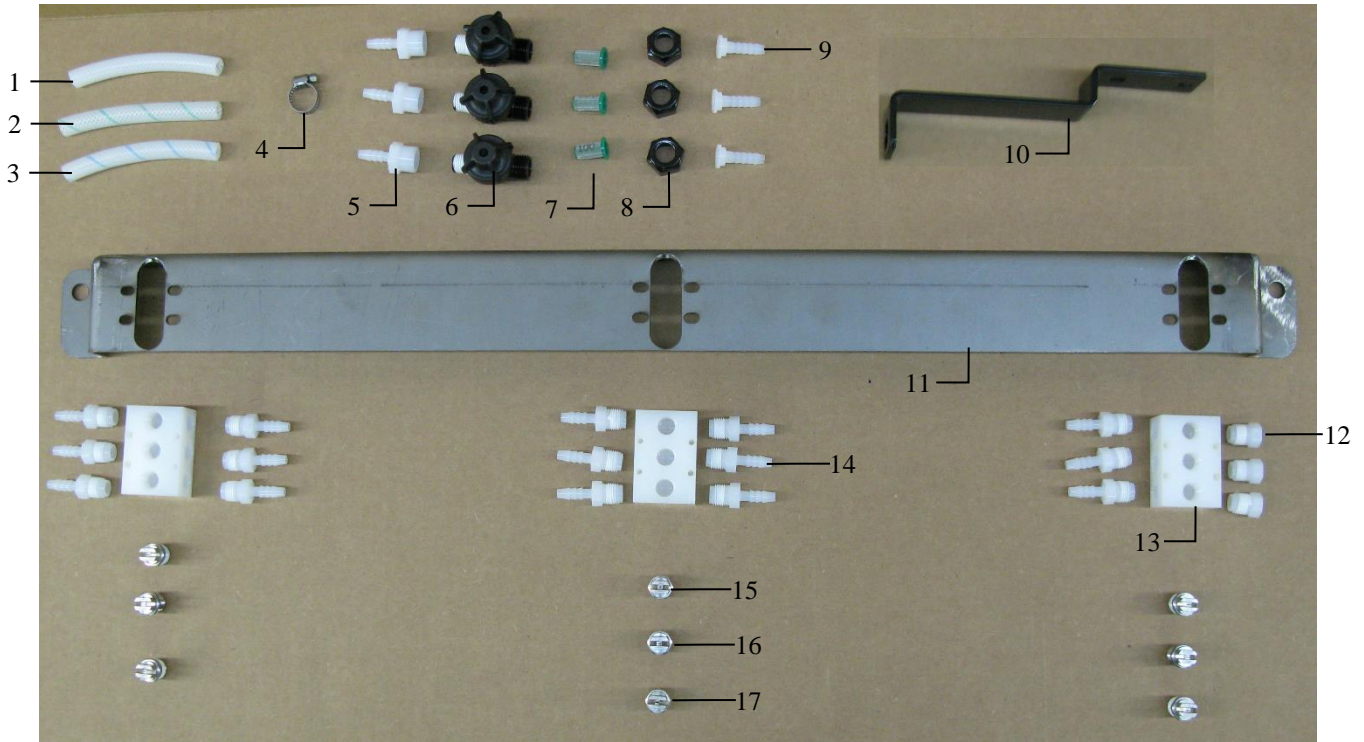

<u>Ref</u>	<u>Description</u>	<u>Part Number</u>	<u>Qty</u>	<u>Ref</u>	<u>Description</u>	<u>Part Number</u>	<u>Qty</u>
1	Hose – Clear	002-9016	4	11	Tip Holder	001-4435NK	1
2	Hose – Green	002-9016G	4	12	Plug Fitting	003-F14	3
3	Hose – Blue	002-9016B	4	13	Manifold Block	001-4435NSB	2
4	Hose Clamp	003-9002	9	14	1/4" x 1/4" Straight	003-A1414	9
5	1/4" Fitting	003-A1414F	3	15	Tip	004-T11003-SS	3
6	Check Valve	004-1207VB	3	16	Tip	004-T110015-SS	3
7	Tip Strainer	004-1203-100	3	17	Tip	004-T11001-SS	3
8	Cap	004-4723	3	NP	Tip	004-T800067-SS	3
9	1/4" x 1/4" Straight	003-A1414VB	3				
10	EOB Holder	001-4648K	1				

Notes

Notes

Notes

Harvest Tec Inc. Warranty and Liability Agreement

Harvest Tec, Inc. will repair or replace components that are found to be defective within 12 months from the date of manufacture. Under no circumstances does this warranty cover any components which in the opinion of Harvest Tec, Inc. have been subjected to negligent use, misuse, alteration, accident, or if repairs have been made with parts other than those manufactured and obtainable from Harvest Tec, Inc.

Our obligation under this warranty is limited to repairing or replacing free of charge to the original purchaser any part that in our judgment shows evidence of defective or improper workmanship, provided the part is returned to Harvest Tec, Inc. within 30 days of the failure. If it is determined that a non-Harvest Tec branded hay preservative has been used inside the Harvest Tec applicator system where the failure occurred, then Harvest Tec reserves the right to deny the warranty request at their discretion. Parts must be returned through the selling dealer and distributor, transportation charges prepaid.

This warranty shall not be interpreted to render Harvest Tec, Inc. liable for injury or damages of any kind, direct, consequential, or contingent, to persons or property. Furthermore, this warranty does not extend to loss of crop, losses caused by delays or any expense prospective profits or for any other reason. Harvest Tec, Inc. shall not be liable for any recovery greater in amount than the cost or repair of defects in workmanship.

There are no warranties, either expressed or implied, of merchantability or fitness for particular purpose intended or fitness for any other reason.

This warranty cannot guarantee that existing conditions beyond the control of Harvest Tec, Inc. will not affect our ability to obtain materials or manufacture necessary replacement parts.

Harvest Tec, Inc. reserves the right to make design changes, improve design, or change specifications, at any time without any contingent obligation to purchasers of machines and parts previously sold.

Revised 4/17

HARVEST TEC, INC.
P.O. BOX 63
2821 HARVEY STREET
HUDSON, WI 54016
PHONE: 715-386-9100
1-800-635-7468
FAX: 715-381-1792
Email: info@harvesttec.com