

Installation Manual

Model 600 ***Moisture Sensor Kit for Large Square Balers***



*Equipment and Products
for Quality Hay.™*

P.O. Box 63 • 2821 Harvey Street • Hudson, WI 54016
800-635-7468 • www.harvesttec.com

DECLARATION OF INCORPORATION



MANUFACTURER:

Harvest Tec Inc.
2821 Harvey St.
P.O. Box 63
Hudson, WI 54016, U.S.A.

REPRESENTATIVE ESTABLISHED IN COMMUNITY: Profitable Farming Company
Middle Barlington, Roborough
Winkleigh, Devon, EX19 8AG
ENGLAND

The person above certifies and declares that:

VIRTUAL MACHINE: Equipment mounted on a farm press and for the application of inoculants onto forage crops.

MODEL: 600-INST-17-Imp&Metric

BRAND: Harvest Tec

SERIAL NUMBER:

This application preservatives for hay Harvest Tec system meets the Directive 2006/42/EC of the European Parliament and the Council of 17 May 2006 and other applicable European Directives including Directive 2004/108/EC on the Electromagnetic compatability.

The application of preservatives for hay Harvest Tec system will be turned on after being installed on a farm press has been declared in conformity with the Machinery Directive.

Person in the community authorized to provide information on the partly completed machinery and making this statement:

Richard Snell, President, Profitable Farming Company

Signed on May 21, 2011: Middle Barlington, Roborough
Winkleigh, Devon, EX19 8AG
ENGLAND

Harvest Tec Model 600 Installation Table of Contents

	<u>PAGE</u>
Introduction	4
Tools Needed	4
Installation of Applicator	5-22
Installation of Dual Channel Processor (DCP)	5
Installation of Star Wheels	6-12
New Holland 590 through BB 9080 & Case IH LBX331 through LB433 balers	6
Case IH 8570, 8575, & 8585, Challenger LB33, LB34, & Hesston 7430, 4750, 4755, 4760, 4790, & Massey Ferguson 2050, & New Idea 7233, 7333, & 7234 balers	7
Case IH 8580, 8590 & Hesston 4900, 4910 & Challenger LB 44 & New Idea 7244	8
Vermeer Balers	9
Claas 2100 & 2200 Balers	10
Claas 3200-3400 Large Square Balers (continued)	11
Krone Large Square Balers	12
Installation of End of Bale Sensor	13-21
All balers end of bale sensor bracket installation guide	14
Hesston 4750-4755 & 4900-4910	15
Hesston 4760 & 4790	15
New Holland 590-BB960, BB9060-BB9080 & Case IH LBX 331-431, LB333-LB433	16
New Holland BB940A-BB960A & Case IH LBX 332-432	17
Claas 2100	18
John Deere 100	19
Krone 890 – 1290	20
Krone 12130	21
Installation of the Bale Rate Harness	21
Main Power and Communication Harness to the Baler Terminator Install	22
Connecting the ISOBUS Plug to the Tractor	22
Installation of iPad Integration Control	23
iPad Integration Control Light Signals	23
Bluetooth Receiver Lights	23
Wiring Diagram	24
Pin Outs	25-26
Troubleshooting	27
Parts Breakdown	28-30
Star Wheel Moisture Sensor	28
600 Series Control and Harnesses	29
Optional iPad Mini Mounting Kit	30
Optional iPad Display Kit	31
Star Wheel Installation Template	32
Notes	33-34
Warranty Statement	35

Introduction

Thank you for purchasing a Harvest Tec Model 600 Moisture Monitor System. This 600 Moisture Monitoring System has been designed to be operated through an Apple iPad (not included) using the Hay App. As well as the option to plug directly into most tractors that have an ISOBUS Monitor. The 600 Moisture Monitoring System offers these advantages by operating through an Apple iPad:

1. Large bright, clear, colorful display
2. More durable and can be read in bright sunlight
3. Can be used for multiple other uses than just the applicator display
4. Option to tie-into the tractor ISOBUS system

There is a part break down for the 600 Moisture Monitoring System is included in the back of this manual. If you do have questions please bring this manual into the dealership. They can assist you in ordering the correct replacement parts.

Right and Left sides are determined by facing in the direction of forward travel.

***Made for iPad® (3rd through Pro 2nd generation), running the current iOS operating system or one version previous required for iPad option**

*iPad is a trademark of Apple Inc., registered in the U.S. and other countries.

****600 Series Applicators with serial number before DCP27000 will require the DCP to be sent to Harvest Tec for a required update in order to use the iPad Integration Module (030-6672C).**

*Hay App version must be **at least 2.5.18 (or higher)** to operate with the iPad Integration Module

If choosing to operate the unit through the ISOBUS monitor, part number 006-6670A will need to be ordered through your local equipment dealer.

Attention:

For kits on 2010 Krone HDP balers Krone part number 20 073 194 0 must be ordered to mount the starwheels.

Please see attached supplemental manual for further instructions.

Tools Needed:

- Standard wrench set
- Electric drill and bits
- Side cutter
- Crescent wrench
- Standard screwdriver
- Center punch
- Standard nut driver set
- Standard socket set
- Hammer
- Metal cutting tools
- Hose cutter

Installation of Dual Channel Processor (DCP)

Follow the instructions below to mount the Dual Channel Processor (DCP) onto your specific baler model and type. The locations shown are the right twine box (looking at the back of the baler). Mark and drill the four 3/8" (10mm) holes and install DCP with two 5/16" x 1" bolts, two 5/16" x 1-1/4" bolts, locks, fender washers and hex nuts. If your baler is not listed below mount the DCP on the back of the twine box on the right side. Mount the DCP cover over the top of the tip and secure with the hardware using the 5/16" x 1-1/4" bolts on the top with the DCP/PIP shield.

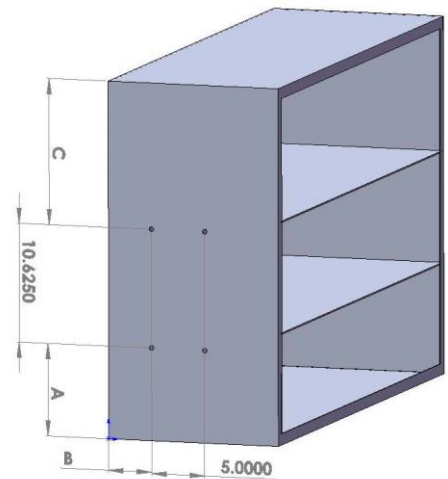

Baler Type	Model number	A	B	C	Baler Type	Model number	Fig.	A	B	C
					Hesston	4750 - 4755	1	16" (40cm)	2" (51mm)	N/A
Case IH	LBX 331 – 431	4" (10cm)	2" (51mm)	N/A	Hesston	4760	1	2" (51mm)	2" (51mm)	N/A
Case IH	LBX 332-432 & LB 333 - 433	N/A	2" (51mm)	2" (51mm)	Hesston	4790	1	4" (10cm)	2.5"	N/A
					Hesston	4800 - 4910	1	16" (40cm)	2" (51mm)	N/A
Challenger	LB33	2" (51mm)	2" (51mm)	N/A	John Deere	100	1	18" (45cm)	6.5"	N/A
Challenger	LB34	4" (10cm)	2.5" (64mm)	N/A	Krone	890 – 12130	1	3" (70mm)	4" (10cm)	N/A
Challenger	LB44	16" (40cm)	2" (51mm)	N/A	New Holland	590 – BB940	1	4" (10cm)	2" (51mm)	N/A
Claas	2100	4" (10cm)	2" (51mm)	N/A	New Holland	BB940A – 960A & BB9060 – BB9080	1	N/A	2" (51mm)	2" (51mm)
Claas	3300	4" (10cm)	2" (51mm)	N/A	Massey Ferguson	2050	1	2" (51mm)	2" (51mm)	N/A

Installation of Star Wheel Moisture Sensors

Use the template located in the back of this manual as a guide for cutting a notch and locating the mounting holes for the star wheels. Carefully mark the location of the star wheel holes using the template and a center punch so the star wheels will run true to the direction of the bales, otherwise, the star wheels may work themselves out of the block, damaging the sensor itself or the bale rate sensors.

The star wheels must be mounted so that they are no closer than 3/8" (10mm) from any metal parts of the baler and come in contact only with the bale. Four 5/16" x 3" Allen headed bolts will be used to mount the star wheel block and twine guard to the baler. The bolts must be inserted from the inside of the baler chamber. Use nuts and lock washers to hold the bolts in place before putting on the star wheel block, the block is counter-bored on one side so the block will fit over the nuts. The star wheel block has a plug on one side and a wire grommet on the other side. If there are interference problems with the star wheel wires on one side of the block, exchange the wire grommet with the plug so the wire can exit the block on the other side. Mount the twine guards using the two inner holes on the star wheel block. The twine guard containing the bale rate sensors should be placed on the baler's right side, when looking from the back of the baler.

New Holland 590 through BB9080 and Case IH LBX331 through LB 433 balers

Star Wheel Mounting - Use the template located in the back of the manual as a guide for cutting the notch and mounting holes for the star wheels. The star wheels are to be mounted on top of the baler, just behind the knotters and under the walkway on both sides. Remove the bale from the chute, tip the walkway up and locate the wheels on the top outside corner angles of the bale chute, one on each side. Some balers may already have the notch cut and square holes. If so, the holes will need to be drilled round with a 5/16" (8mm) drill bit. A 1/2" x 1/2" (13mm x 13mm) cut may also need to be made at the base of the twine arm mounting bracket for the star wheel to sit correctly on the bale chamber. Mark the location of the notch 5/8" (16mm) wide and 9" (23cm) long) and the location of the four 5/16" holes for the star wheel base. After cutting the notch and drilling the hole, insert the 5/16" x 3" (8mm x 70mm) black Allen head bolts up through the chute and use nuts to hold the bolts in place. Place the star wheel block over the nuts and install the twine guards using the two inner holes of the star wheel block. The twine guard containing the bale rate sensors will be placed on the right side. See Step 8 for directions on how to hook-up the star wheel wires.

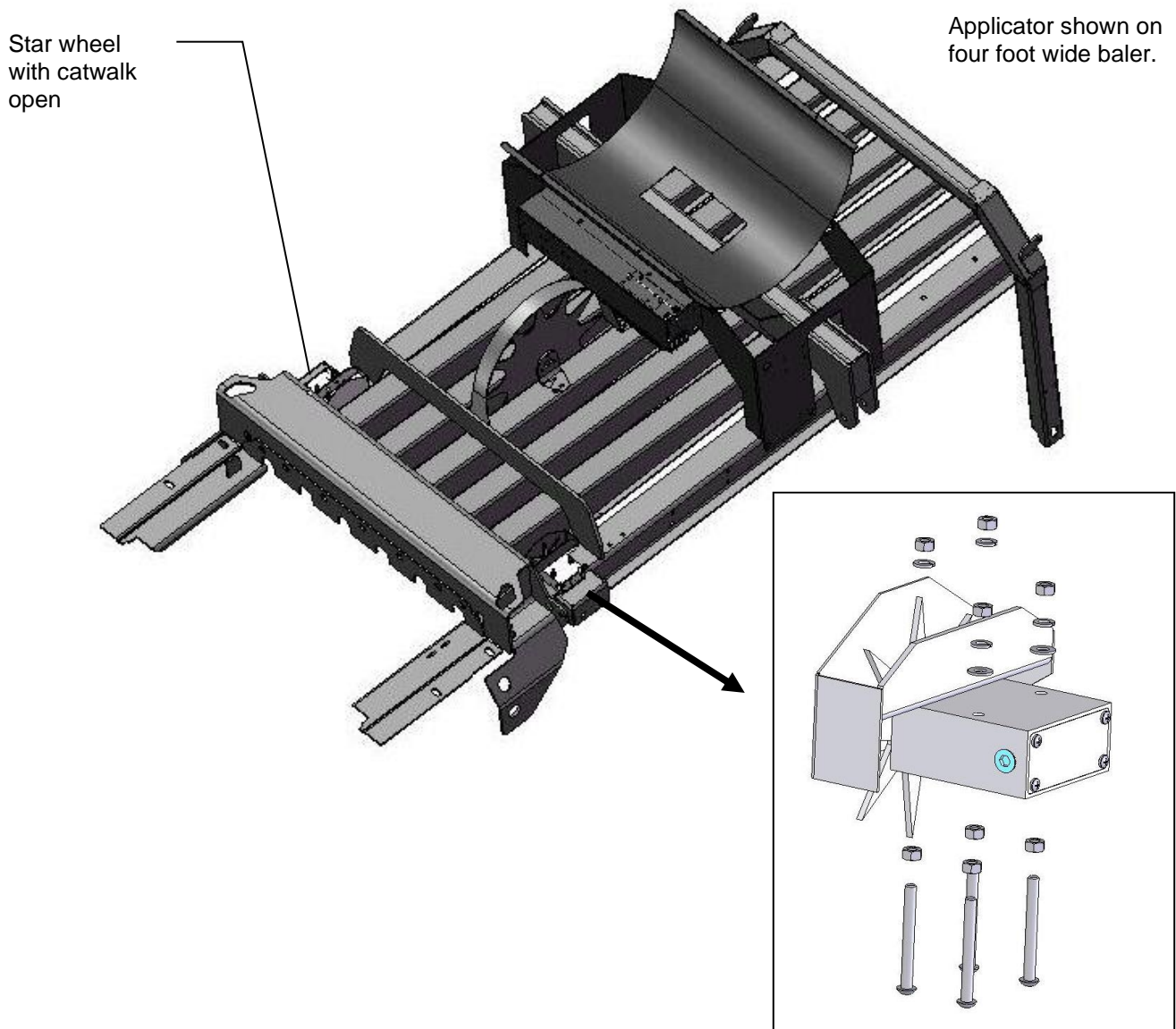

Case IH 8570, 8575, and 8585, Challenger LB33, LB34, and Hesston 7430, 4750, 4755, 4760, and 4790, and Massey Ferguson 2050, and New Idea 7233, 7333, 7234 balers

Star Wheel Mounting- The star wheels are mounted under the walkway on top of the baler behind the knotters. Remove the bale from the chute and tip the walkway up. Locate the star wheel template on the outside corner angles of the bale chute on the left and right side of the baler. The center of the wheel shaft will be approximately 5-1/2" (12.5cm) in front of the walkway support or about halfway between the walkway support and the cross frame almost directly in front of it. The notch will start just in front of the walkway support.

Two parts of the baler frame will have to be trimmed off on both sides to mount each star wheel. The first is the outside corner angles of the chute. Use the template to mark the location of the star wheel notch as well as the location of the four holes for the star wheel base. The notch will be 5/8" by 9" (16mm x 23cm) long and will help keep the wheel away from the twine. Spray the ground off areas with touch up paint to prevent rusting. The second portion of the baler to trim off is the end of the gusset that may interfere with the star wheel's plastic base support. Center the star wheel in the slots that was just notched and check for interference with the gusset.

Drill 5/16" holes for the star wheel block. Insert the 5/16" x 3" (8mm x 70mm) bolts up through the chute and use nuts to hold the bolts in place. Place the star wheel block over the nuts and install the twine guards using the two inner holes of the star wheel block. **The twine guard containing the bale rate sensors will be placed on the right side of the baler.** See Step 8 for directions on how to hook-up the star wheel wires.

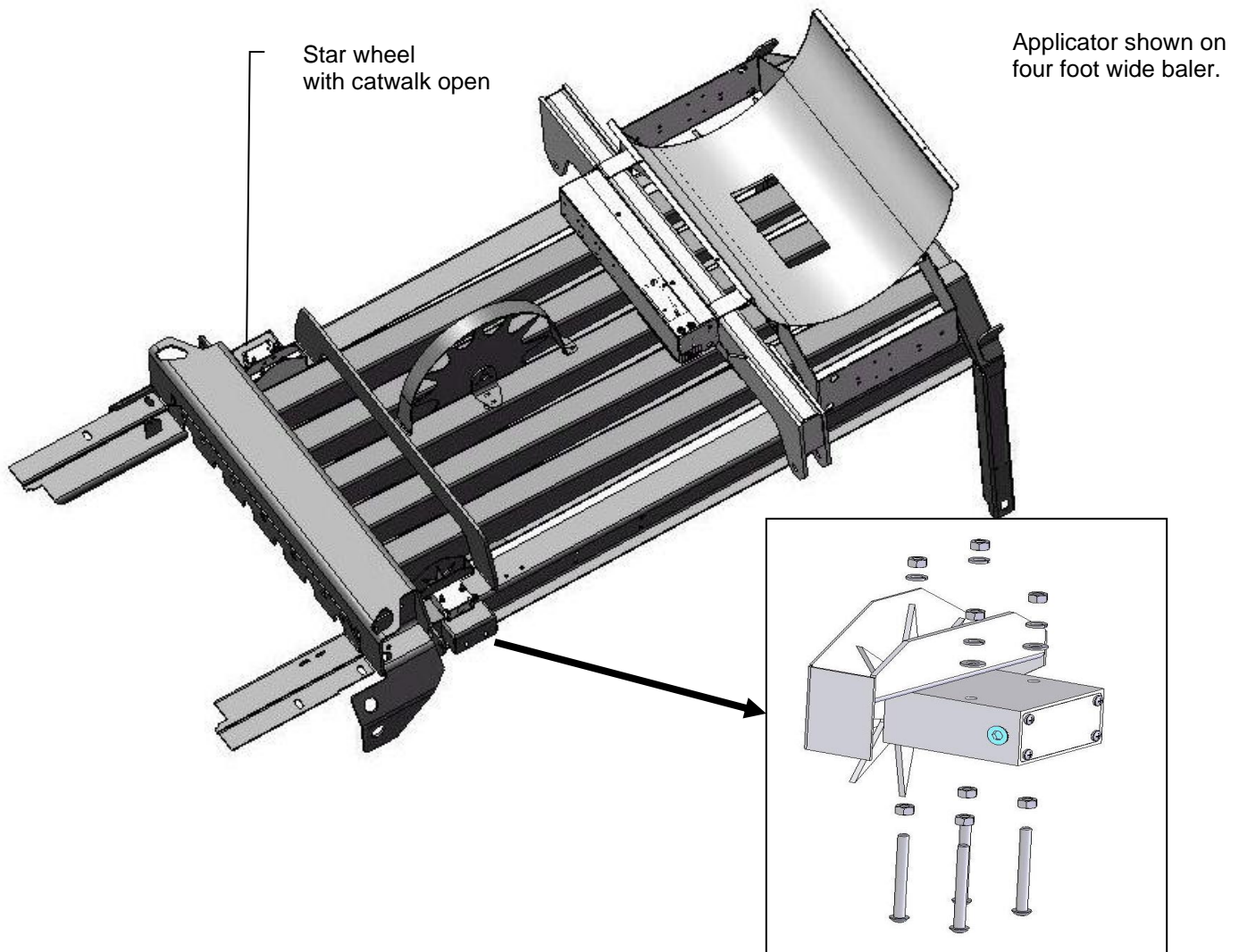

Case IH 8580 and 8590, Hesston 4900 and 4910, Challenger LB44, and New Idea 7244 balers

Star Wheel Mounting-The star wheels are mounted on top of the baler, just behind the knotters under the walkway on both sides. Use the template at the back of the manual to mark the location and dimension of the notch and holes. Remove the bale from the chute. Tip the walkway up and locate the wheels on the top outside corner angles of the bale chute, one on each side. The star wheel block is located just in front of the horizontal channels holding the twine boxes. Using the template and a center punch mark the location of the notch (5/8" wide and 9" long) (16mm x 23cm) and the location of the four 5/16" (8mm) holes for the star wheelbase. Any bare metal edge of the angle should be sprayed with touch up paint to prevent corrosion.

Once the above modification to the baler is made on both sides of the chute, the wheels can be mounted. Insert the 5/16" x 3" (8mm x 70mm) bolts up through the chute and use nuts to hold the bolts in place. Place the star wheel block over the nuts and install the twine guards using the two inner holes of the star wheel block. **The twine guard containing the bale rate sensors will be placed on the right side of the baler.** See Step 8 for directions on how to hook-up the star wheel wires.

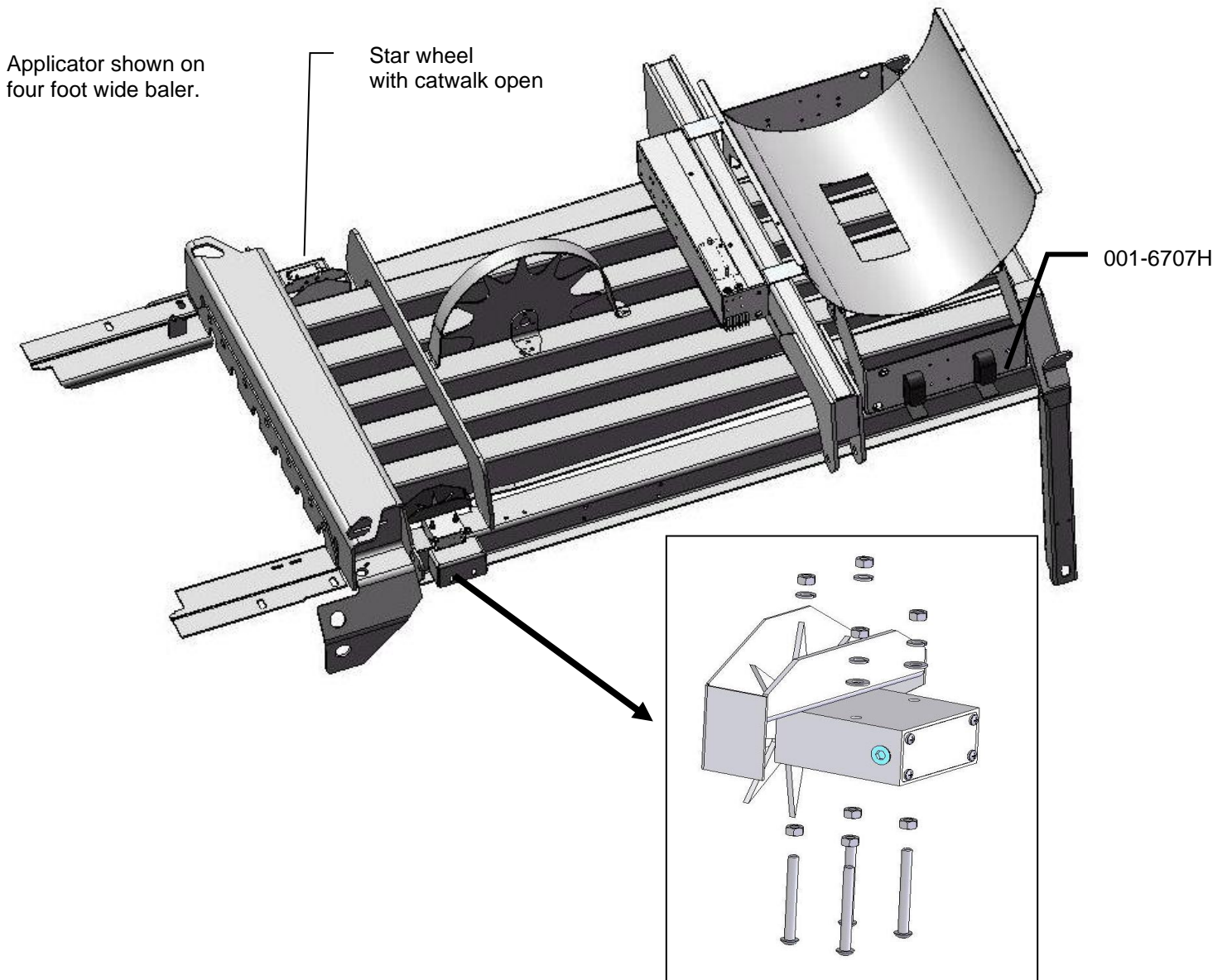

Vermeer SQ2731 and SQ3347 balers

Star Wheel Mounting-Locate the steel crossbeam that goes across the bale chamber in between the knotters and shield for the hydraulic cylinder. The yellow shield is located in the middle and runs in the same direction as the bale chamber. Using the provided star wheel template, locate the template as far forward as possible behind the crossbeam. Position the template so the edge of the star wheel base is aligned with the outside of the bale chamber. Mark the hole positions for drilling and also mark the notch for the star wheels. The notch will be $5/8$ " (16mm) by 9" (23cm) long and will help keep the wheel away from the twine. Repeat this process on the other side of the bale chamber for the second star wheel. Insert the $5/16$ " x 3" (8mm x 70mm) bolts up through the chute and use nuts to hold the bolts in place. Place the star wheel block over the nuts and install the twine guards using the two inner holes of the star wheel block. **The twine guard containing the bale rate sensors will be placed on the right side of the baler.** See Step 8 for directions on how to hook-up the star wheel wires.

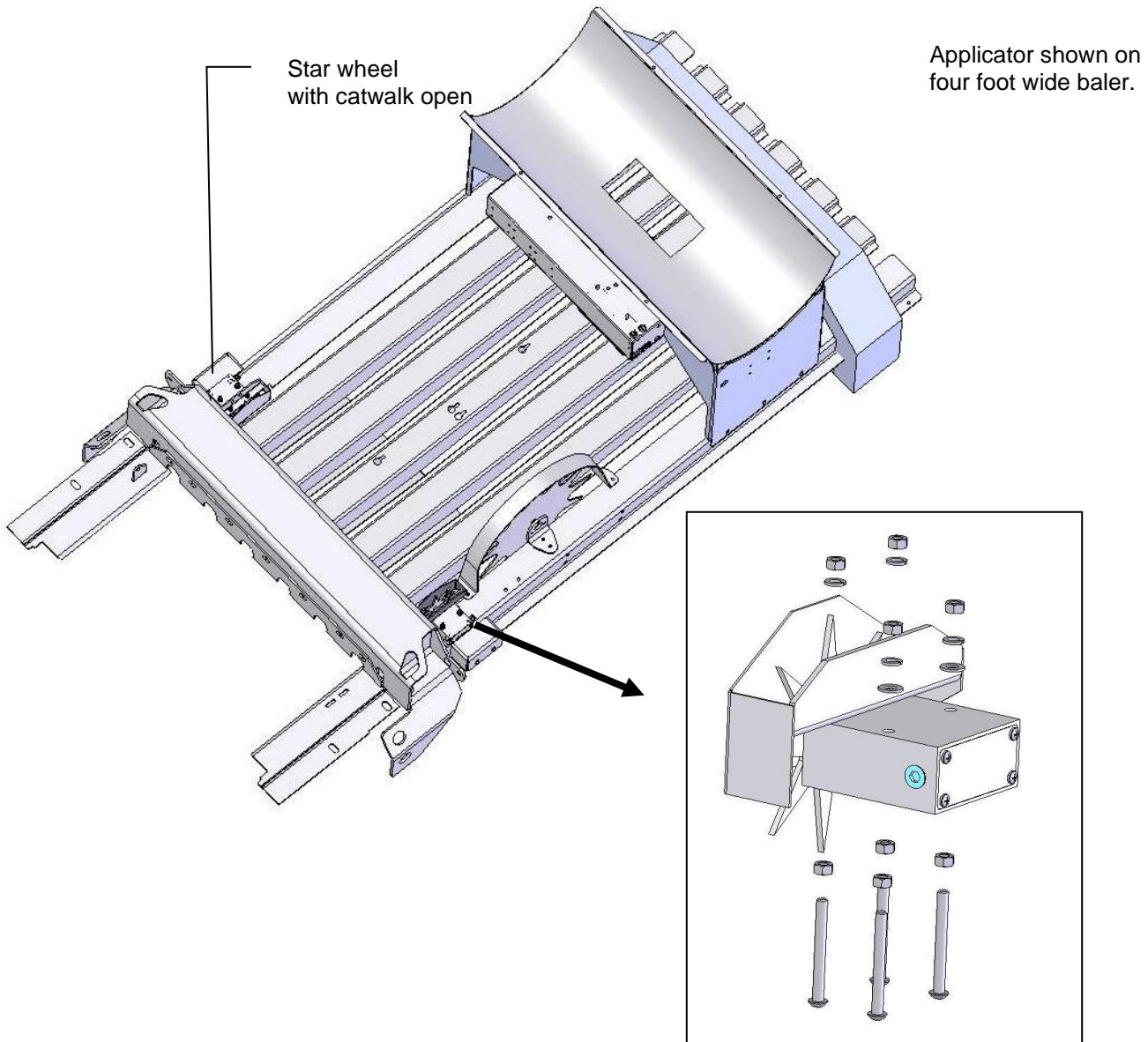

Claas 2100 and 2200 balers

Star Wheel Mounting-Use the template located in the back of the manual as a guide for cutting the notch and mounting holes for the star wheels. The star wheels are to be mounted on top of the baler, just behind the knotters and as far forward as possible. Remove the bale from the chute. Locate the wheels on the top outside corner angles of the bale chute, one on each side. Mark the location of the notch (5/8" (16mm) wide and 9" (23cm) long) and the location of the four 5/16" (8mm) holes for the star wheel base. After cutting the notch and drilling the hole, insert the 5/16" x 3" (8mm x 70mm) black Allen head bolts up through the chute and use nuts to hold the bolts in place. Place the star wheel block over the nuts and install the twine guards using the two inner holes of the star wheel block. **The twine guard containing the bale rate sensors will be placed on the right side.** See Step 8 for directions on how to hook-up the star wheel wires.

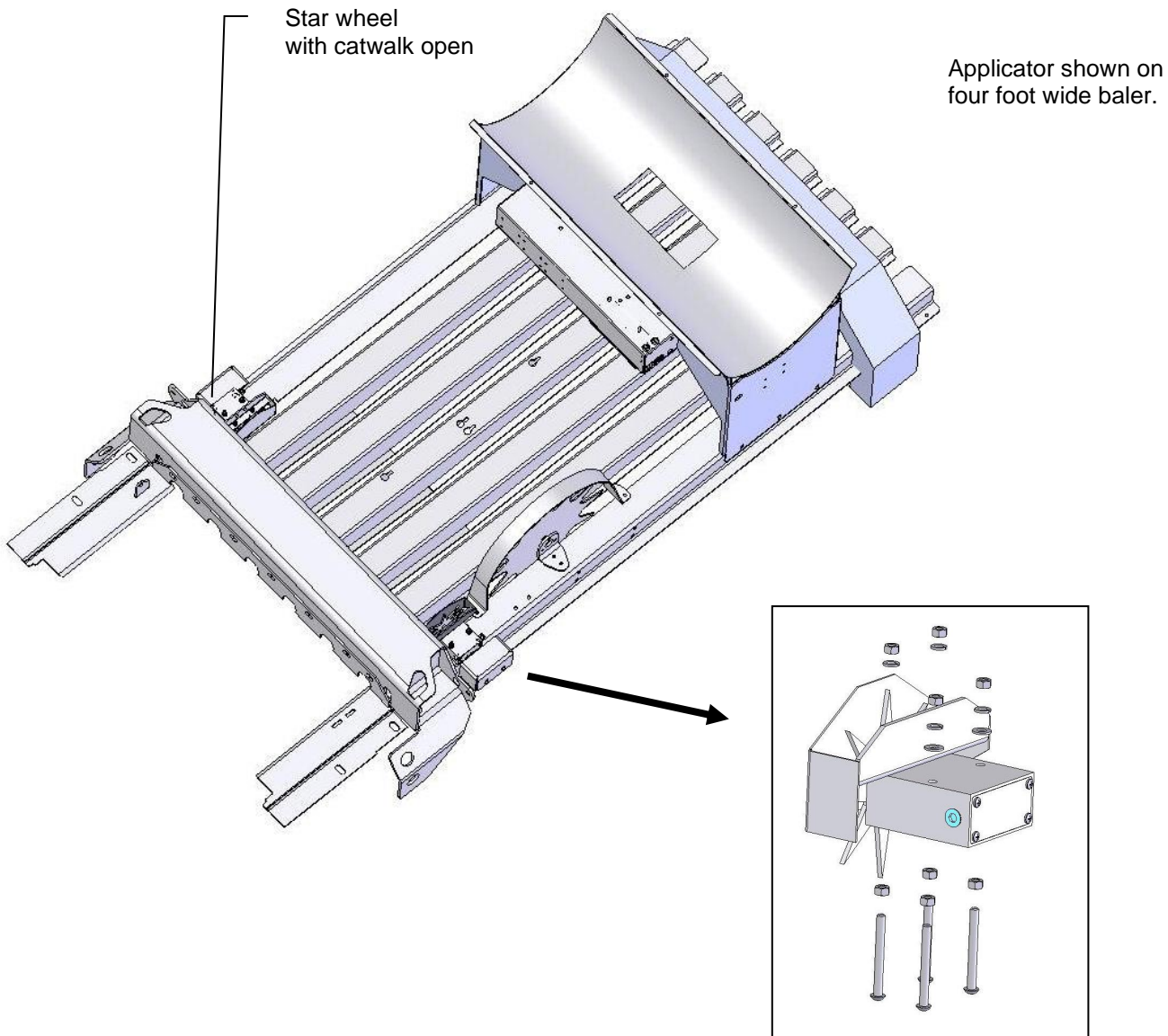

Claas 3200-3400 Large Square Balers continued

Star Wheel Mounting – Use the picture below as a guide for drilling the mounting holes for the star wheels. The star wheels are to be mounted on the side of the bale chamber, between the top and middle channel. Measure 10" back from the hinge between the top and middle channel. Cut 1" x 9" (25mm x 23cm) slot for the star wheel. Make sure the wheel is square. Mark the location of the two 5/16" (8mm) holes for the star wheel base. After drilling the holes, insert the 5/16" by 3 1/4" allen head bolts through the chute and use nuts to hold the bolts in place. Place the star wheel block over the nuts and install the prox sensor holder (001-4644H) on the star wheel located on the right side of the baler. Note: Thicker side of block goes to baler side.



Krone large square

Star Wheel Mounting-For non-HDP models remove the bale for the bale chute. The star wheels are to be mounted on top of the baler, just behind the knotters and as far forward as possible. Use the table and diagram below to mark the four bolt hole locations on the bale chamber (C,D,E,F). Use the template in the back of the manual to mark the location of the notch to be cut. When cutting the notch both the vertical brace and the bale chamber will need to be cut. Before cutting verify the notch measurement with the below diagram using marks A & B. After cutting the notch and drilling the holes, insert the 5/16" x 3" (8mm x 70mm) black Allen head bolts up through the chute and use nuts to hold the bolts in place. Place the star wheel block over the nuts and install the twine guards using the two inner holes of the star wheel block. **The twine guard containing the bale rate sensors will be placed on the right side.** See Step 8 for directions on how to hook-up the star wheel wires.

For 2010 Krone HDP part number 20 073 194 0 must be ordered. This kit will include mounting instructions for the star wheels.

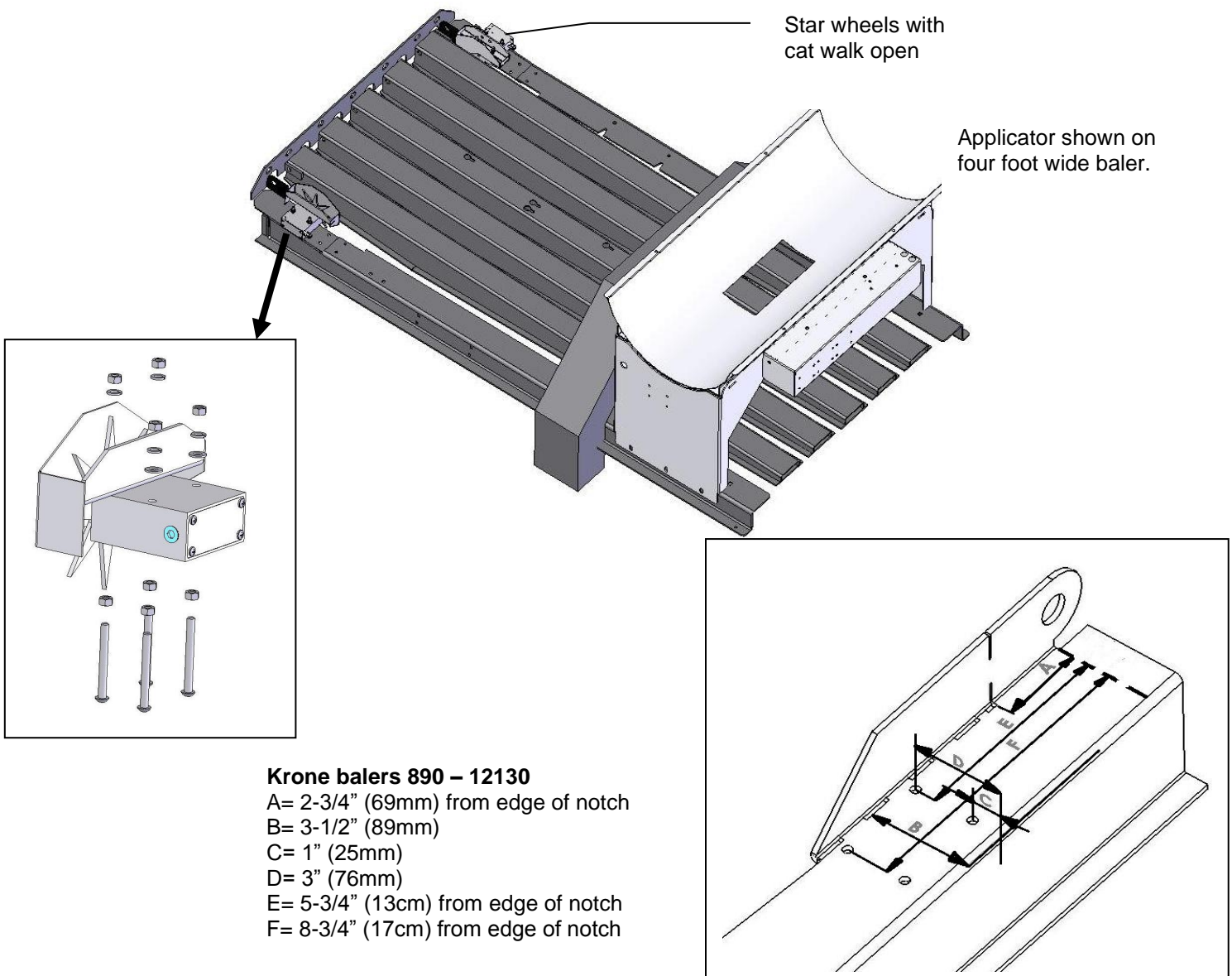

Installation of End of Bale Sensor

The end of bale sensor determines the position of the needles on the baler. When the needles cycle the sensor communicates this information to the Dual Channel Processor (DCP). This information is used for job records and will be used by the optional Bale Identification System. Follow the steps below for your baler to mount the sensor.

All AGCO Hesston 4760 – 4790, and equivalents, Case IH LBX 331 – LB 433, Class 2100, John Deere 100, New Holland 590 – BB 9080

End of bale sensor bracket (001-4648) will be used. Cutoff excess metal not used during installation.

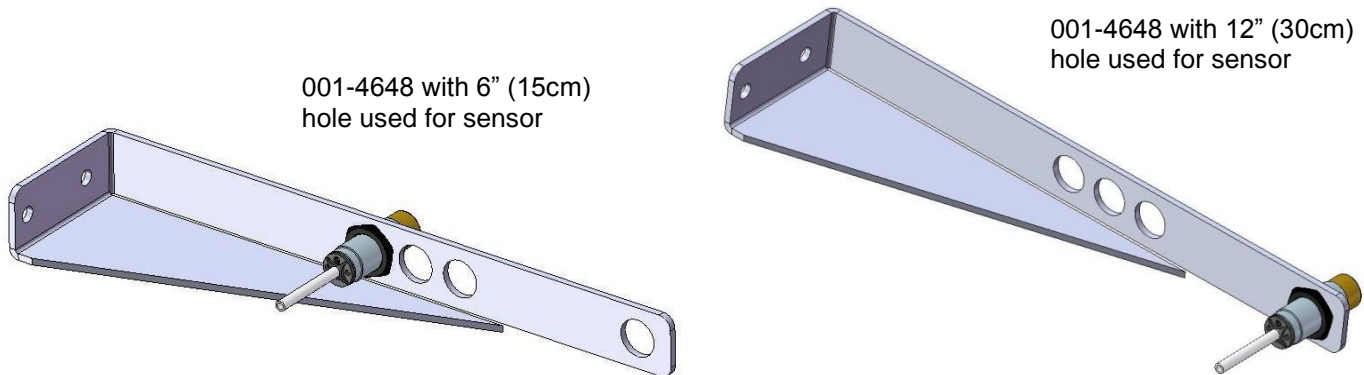

All Hesston 4750 – 4755 & 4900 – 4910

End of bale sensor bracket (001-4648) and Hesston end of bale mount (001-4648H) will be used. The Hesston end of bale mount will be found in the installation kit box. Cutoff excess metal not used during installation.

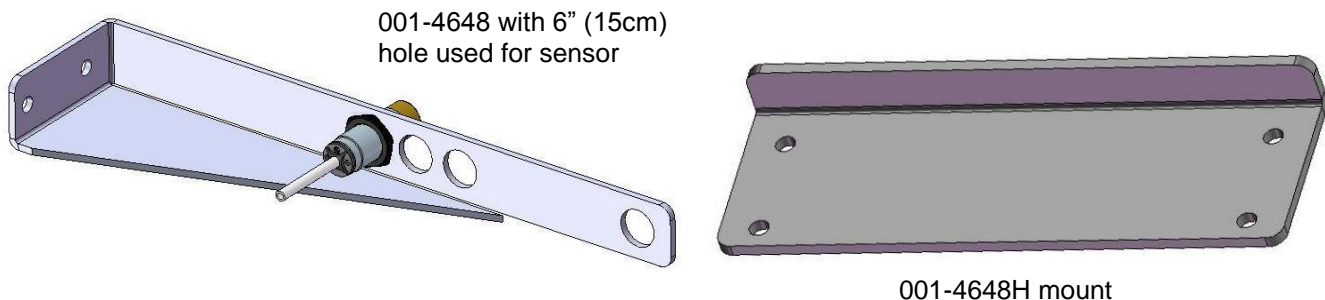

All Krone 890 -12130

Krone End of bale sensor bracket (001-4648K or 001-4648K2) be used. The Krone end of bale mount will be found in the installation kit box. The 001-4648K will be used with balers 890 – 1290. The 001-4648K2 will be used with the 12130 baler.

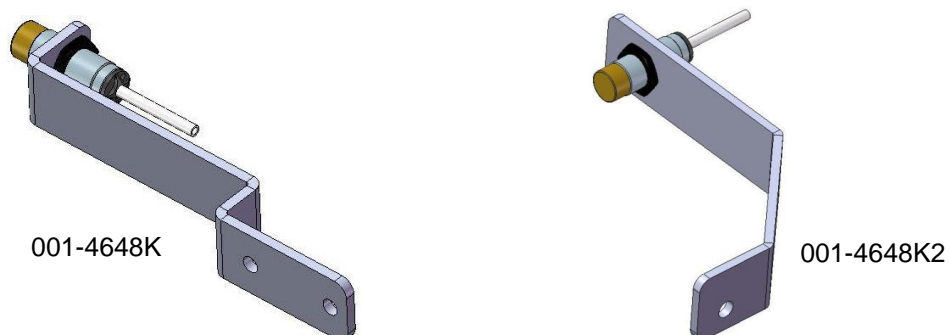

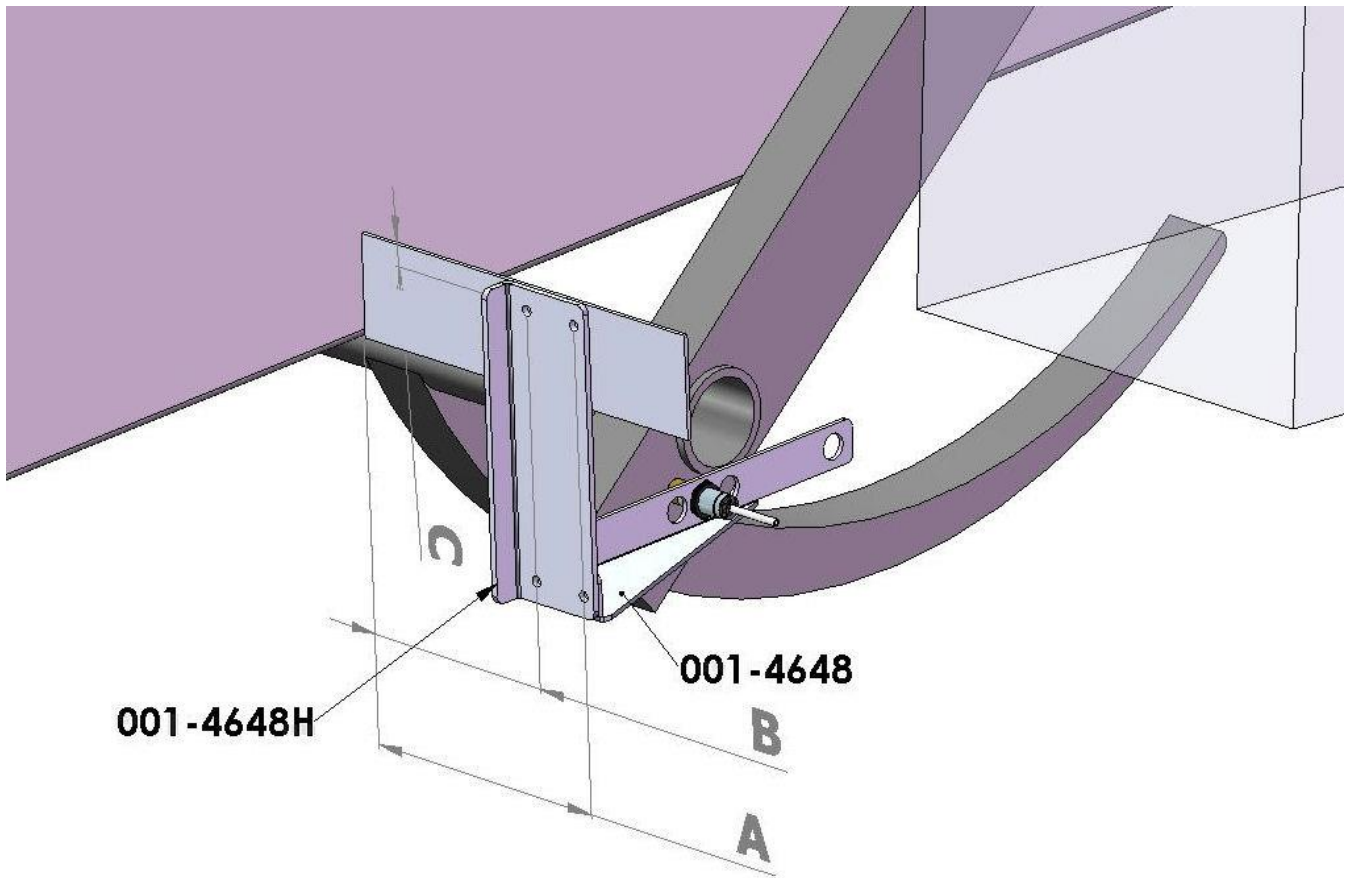

Sensor hole location	A	B	C
7"	7-7/8"	9-5/8"	5/8"
(18cm)	(19cm)	(25cm)	(16mm)

Attach the Hesston end of bale mount (001-4648H) as shown. Attach the end of bale sensor bracket (001-4648) to the Hesston end of bale mount (001-4648H) using two 1/4" x 1" bolts, locks & flat washers and hex nuts. Align the brackets and mark the two 3/8" (10mm) holes to be drilled. Attach the brackets to the baler using two 5/16" x 1 self-tapping screws, and flange nuts. Mount the sensor in the 7" (18cm) hole location, keep the sensor 1/4" (7mm) from the needle and tighten both nuts. Cut off excess metal past the sensor. Run the sensor cable up to the Precision Information Processor and secure to the baler.

Hesston 4760 & 4790

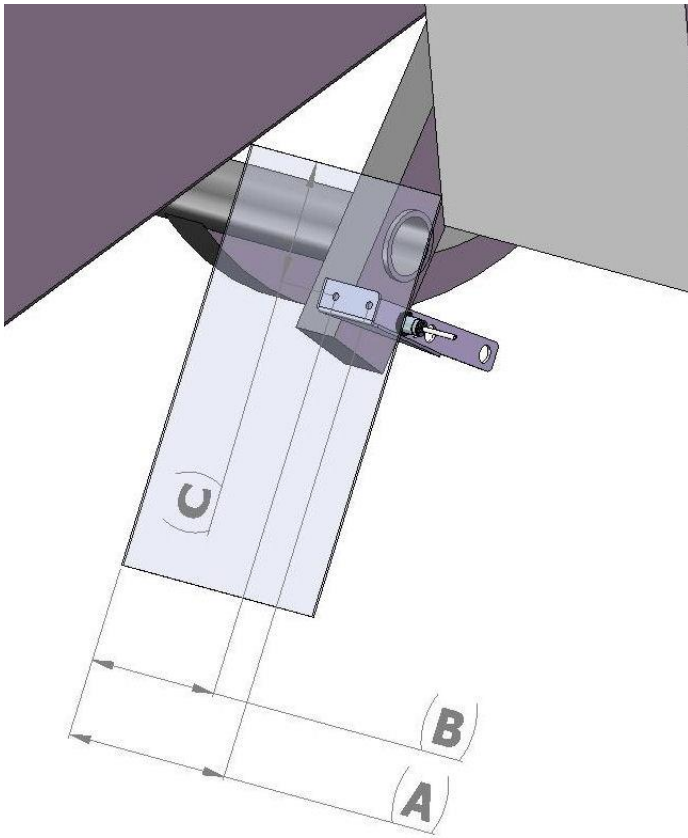

Hesston 4760

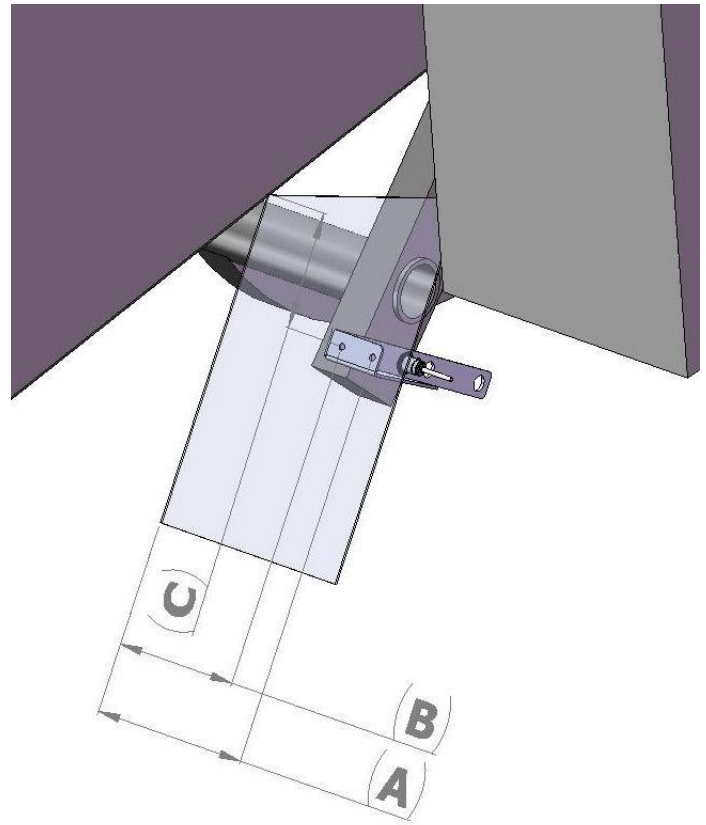

Hesston 4790

Baler	Sensor hole location	A	B	C
4760	6" (15cm)	6-5/8" (17cm)	4-7/8" (13cm)	4" (10cm)
4790	6" (15cm)	4-5/8" (12cm)	2-7/8" (7cm)	3" (8cm)

Mount the end of bale sensor bracket (001-4648) as shown. Mark and drill two 3/8" (10mm) Øholes and attach the bracket using two 5/16" x 1" self-tapping screws, and 5/16" flange nuts. Mount the sensor in the 6" (15cm) hole location, keep the sensor 1/4" (7mm) from the needle and tighten both nuts. Cut off excess metal past the sensor. Run the sensor cable up to the Dual Channel Processor (DCP) and secure to the baler.

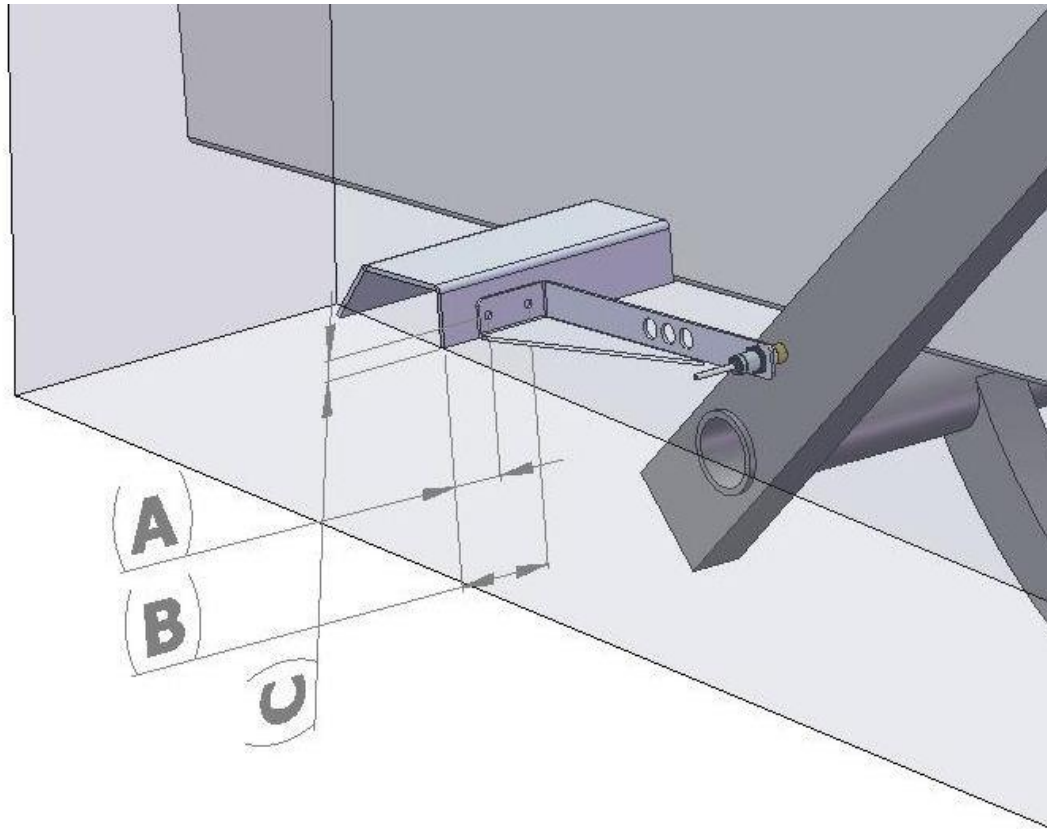

Sensor hole location	A	B	C
12" (30cm)	2-7/9" (7cm)	4-3/8" (10cm)	5/8" (16mm)

Mount the end of bale sensor bracket (001-4648) as shown. Mark and drill two 3/8" (10mm) holes and attach the bracket using two 5/16" x 1" self-tapping screws, and 5/16" flange nuts. Mount the sensor in the 12" (30cm) hole location, keep the sensor 1/4" (7mm) from the needle and tighten both nuts. Run the sensor cable up to the Dual Channel Processor (DCP) and secure to the baler.

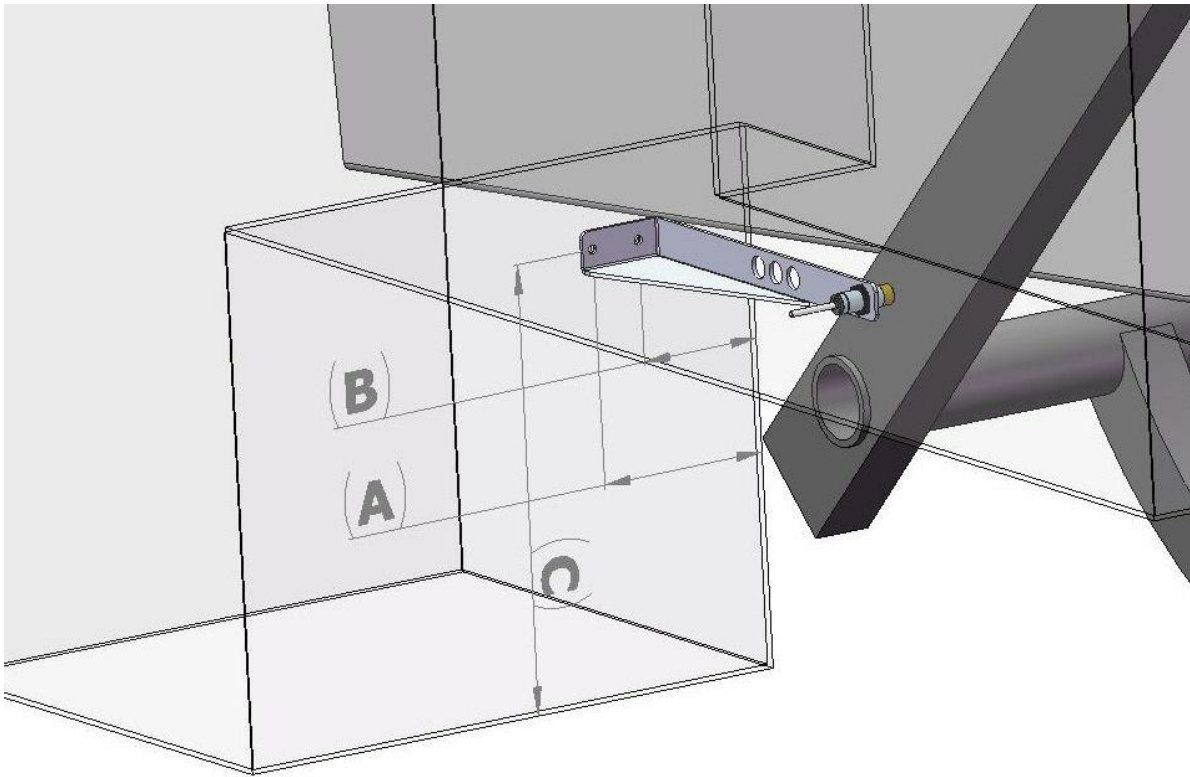

Sensor hole location	A	B	C
12" (30cm)	6-1/8" (16cm)	4-3/8" (10cm)	15" (37cm)

Mount the end of bale sensor bracket (001-4648) as shown. Mark and drill two 3/8" (10mm) holes and attach the bracket using two 5/16" x 1" self-tapping screws, and 5/16" flange nuts. Mount the sensor in the 12" (30cm) hole location, keep the sensor 1/4" (7mm) from the needle and tighten both nuts. Run the sensor cable up to the Dual Channel Processor (DCP) and secure to the baler.

Claas 2100

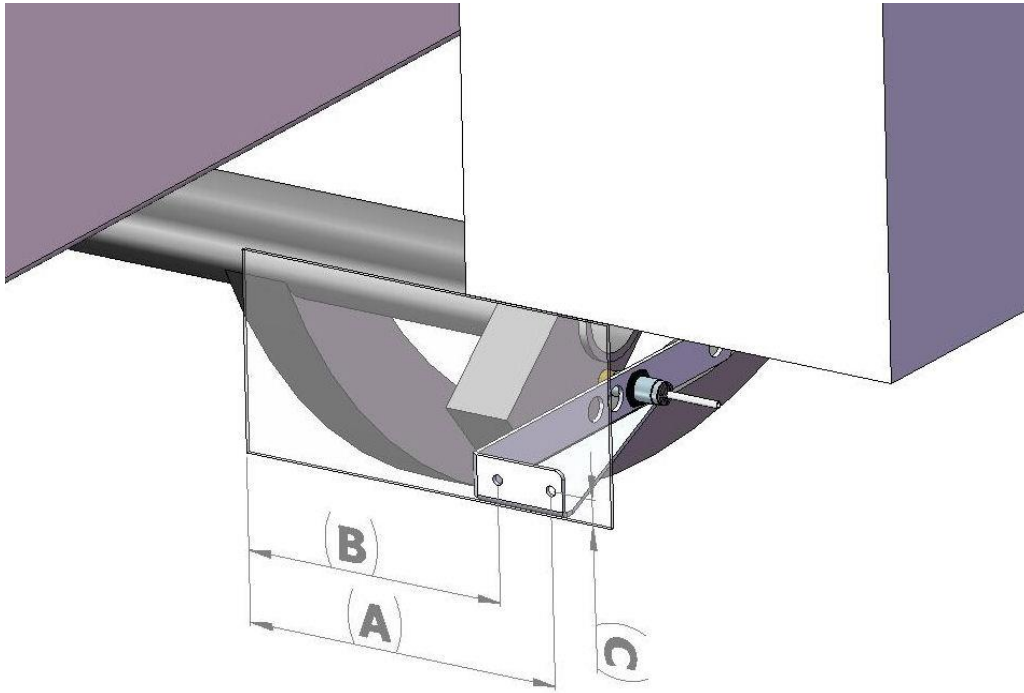

Sensor hole location	A	B	C
8" (20cm)	5-3/4" (14cm)	4" (9cm)	5/8" (16mm)

Mount the end of bale sensor bracket (001-4648) as shown. Mark and drill two 3/8" (10mm) holes and attach the bracket using two 5/16" x 1" self-tapping screws, and 5/16" flange nuts. Mount the sensor in the 8" (20cm) hole location, keep the sensor 1/4" (7mm) from the needle and tighten both nuts. Cut off excess metal past the sensor. Run the sensor cable up to the Dual Channel Processor (DCP) and secure to the baler.

CLAAS 3200-3400

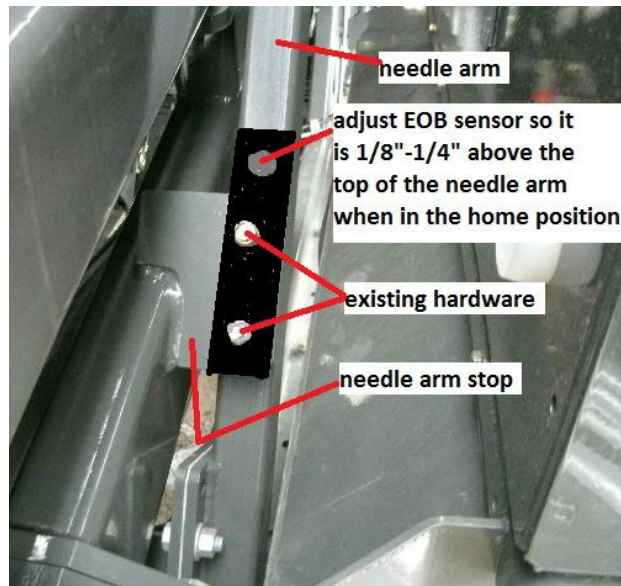
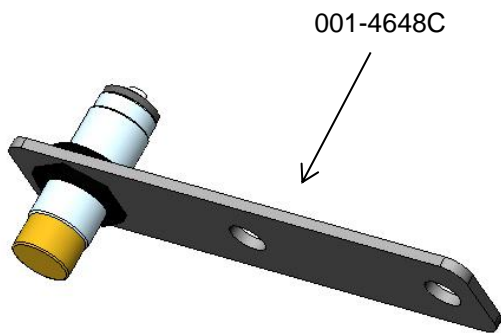

The end of bale (EOB) sensor mounts in the EOB bracket (001-4648C) as shown in the picture. The EOB bracket is mounted to the top side of the needle arm stop using the existing hardware that secures the bumper to the stop.

John Deere 100

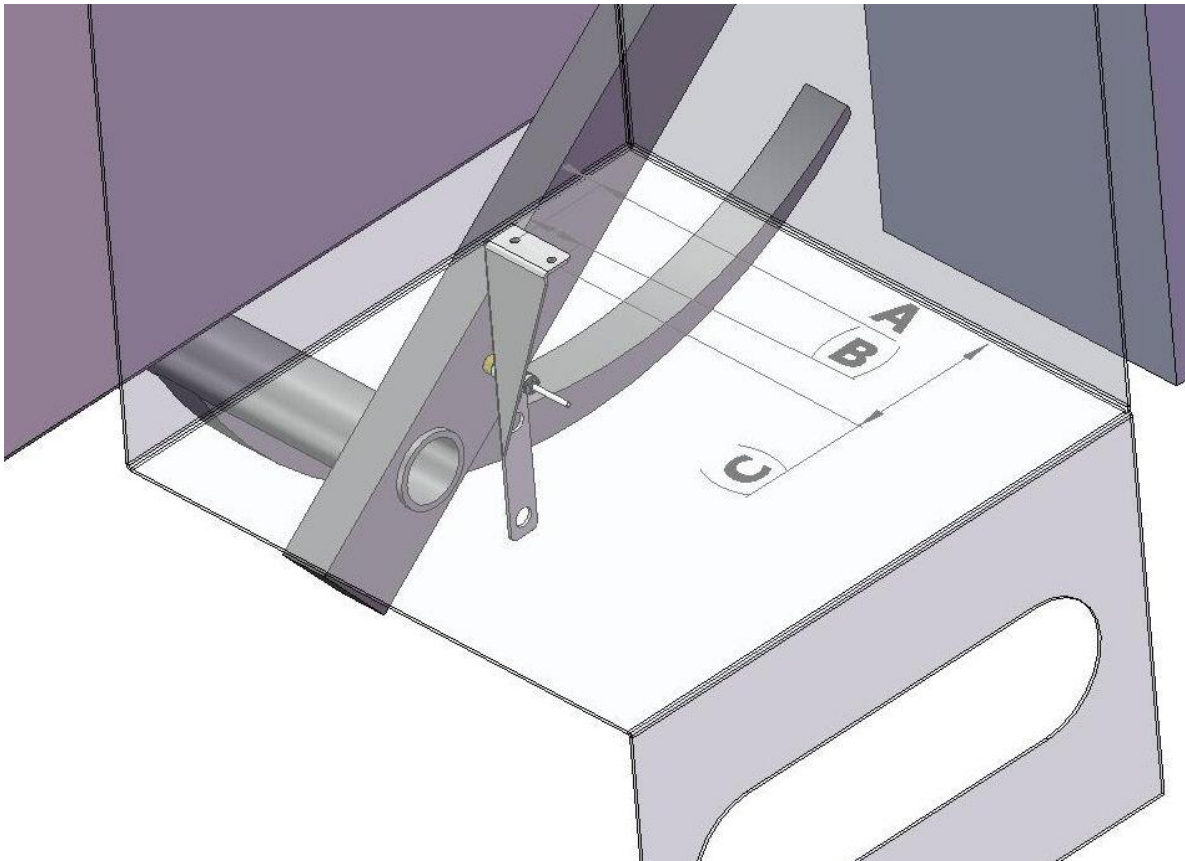

Sensor hole location	A	B	C
6" (15cm)	2-5/8" (70mm)	7/8" (20mm)	7" (20cm)

Mount the end of bale sensor bracket (001-4648) as shown. Mark and drill two 3/8" (10mm) holes and attach the bracket using two 5/16" x 1" self-tapping screws, and 5/16" flange nuts. Mount the sensor in the 6" (15cm) hole location, keep the sensor 1/4" (7mm) from the needle and tighten both nuts. Cut off excess metal past the sensor. Run the sensor cable up to the Dual Channel Processor (DCP) and secure to the baler.

Krone 890 – 1290

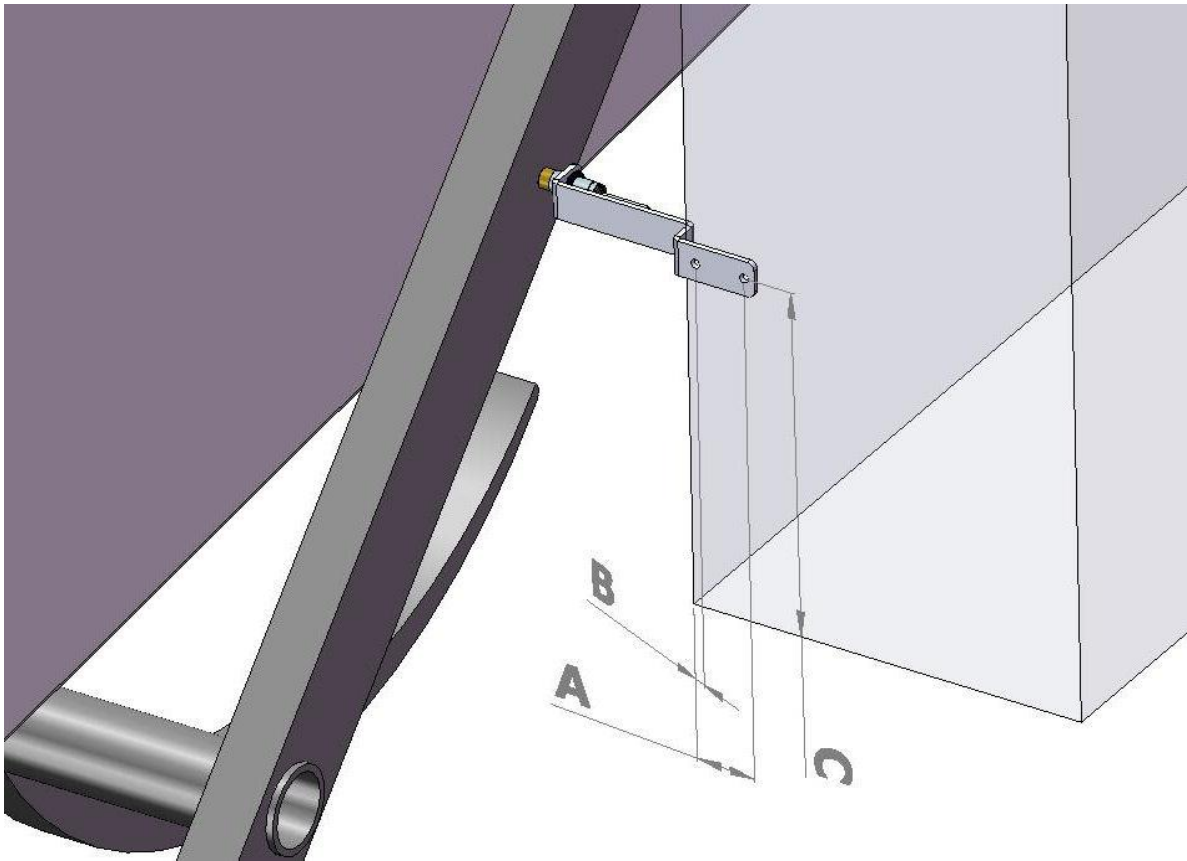

Sensor hole location	A	B	C
N/A	2-1/4" (55mm)	1/2" (13mm)	8" (21cm)

Mount the Krone end of bale sensor bracket (001-4648K) as shown. The Krone mounting bracket can be found in the installation kit box. Mark and drill two 3/8" (10mm) holes and attach the bracket using two 5/16" x 1" self-tapping screws, and 5/16" flange nuts. Mount the sensor at the end of the bracket, keep the sensor 1/4" (7mm) from the needle and tighten both nuts. Run the sensor cable up to the Dual Channel Processor (DCP) and secure to the baler.

Krone 12130

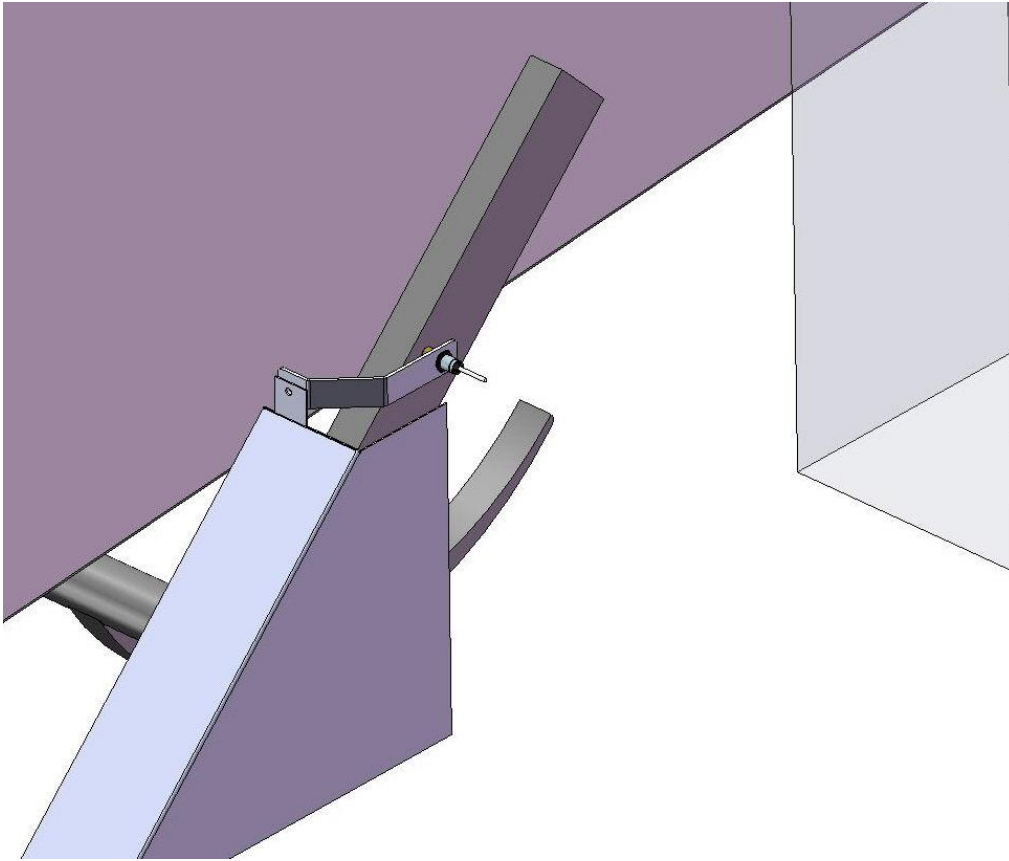

Mount the Krone end of bale sensor bracket (001-4648K2) as shown. The Krone mounting bracket can be found in the installation kit box. Directly behind the twine box on the right side of the baler remove the bolt and nut that secures the fiberglass baler shield to the baler. Mount the sensor bracket using the 3/8 x 1 bolt, lock and nut. Mount the sensor at the end of the bracket, keep the sensor 1/4" (7mm) from the needle and tighten both nuts. Run the sensor cable up to the Dual Channel Processor (DCP) and secure to the baler.

Installation of Bale Rate Harness

First, remove the cover from the star wheel block and use a 1/4" nut driver to remove the nut from the electronic swivel. Next, run the star wheel sensor wire through the black grommet and place the eye terminal on the star wheel sensor. Tighten the eye loop with the nut on the sensor and put the star wheel cover back on the base. Next, tighten the grommet to form a tight seal around the wire. The bale rate sensors will be factory installed on the right side twine guard in the correct position. The sensor with the longer sensor wire should say "FRONT", which indicates it should be placed in the front sensor hole. The sensor wire with the shorter wire should say "BACK." The tip of the sensor should be placed no more than 1/4" (7mm) away from the star wheel teeth and no less than 1/8" (3mm) from the star wheel teeth. Each sensor will have an LED light located on the sensor by the diverter. Once the unit is powered up spin the wheel and make sure that both led lights turn on and off. If they don't turn on and off, adjustments may need to be made.

Once the star wheel connection is complete, run the harness along the baler frame to the Dual Channel Processor (DCP). (See wiring installation on the following page). The Dual Channel Processor is located on the back of the right twine box.

Installation of the Main Power and Communication Harness to the Baler Terminator

Connection at the right rear of the baler.

Route cords 006-6650LS2 along this path or similar inside of the baler. Keep cords away from moving parts and hydraulic hoses. Secure with existing cable clamps or use cable ties. When all connections are made to the DCP secure wires as shown below to allow for water to be shed away from the DCP.

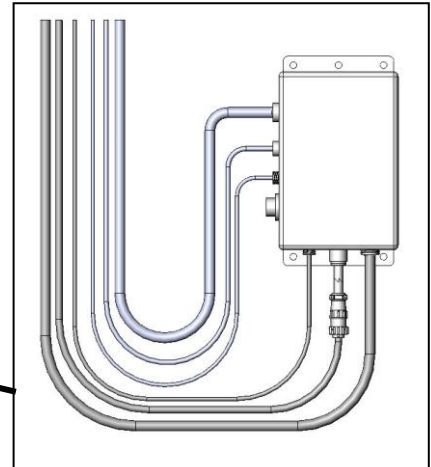

Connecting the optional ISOBUS plug to the tractor

Attach the optional ISOBUS connector (006-6670B) to the end of the communication harness (006-6650TM).

Connect the orange wires and attach the plug to the tractor's ISOBUS port.

Then connect the ISOBUS connector to the ISOBUS plug on the tractor.

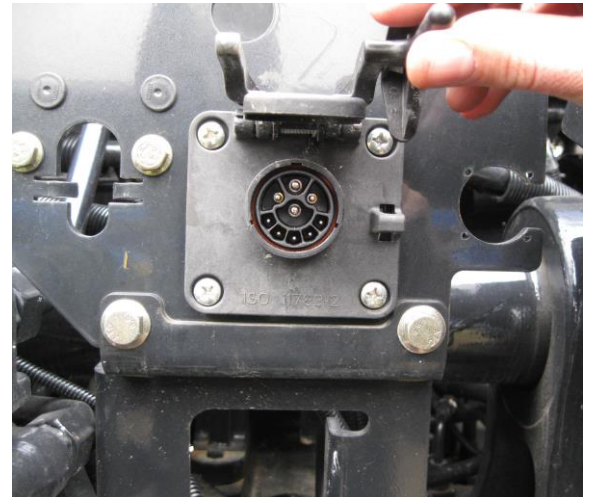

Installation of iPad Integration Control

Locate a safe location in the cab of the tractor to place the iPad Integration Control (030-6672C). Recommended location is securely fastened out of the operators way in a location that is close enough to reach with the iPad cord.

Connect the Power / Communication harness (006-6650TM(E)) to the bottom of the receiver.

To operate the applicator, plug the iPad cord into the communication port indicated by:

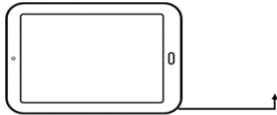

iPad Integration Control Light Signals

Green Slow Blink – Power supplied to the applicator system and the unit is going through its startup process. This will take approximately 25-35 seconds.

Green Double Blink – Indicating the iPad module recognizes the iPad but the app is not open or connected.

Green Solid Light – Module is connected to the app and is ready to operate.

*Recommended to use the USB cable included with the applicator kit (006-6672USBC)

Bluetooth Receiver Lights

Pre-2020 applicators equipped with Bluetooth receivers (030-6672B) are now equipped with lights to indicate both power and Hay App connection on the Apple iPad. Clean light regularly

Blinking Lights – System is waiting for the processor to connect, which could take up to 35 seconds.

Red Light – The Bluetooth receiver has power

Green Light – The Bluetooth receiver is connected to the Hay App.



****600 Series Applicators with serial number before DCP27000 will require the DCP to be sent to Harvest Tec for a required update in order to use the iPad Integration Module (030-6672C).**

Hay App version must be **at least 2.5.18 (or higher)** to operate with the iPad Integration Module

*Made for Apple iPad badge

Use of the Made for Apple iPad badge means that an accessory has been designed to connect specifically to the Apple product(s) identified in the badge and has been certified by the developer to meet Apple performance standards. Apple is not responsible for the operation of this device or its compliance with safety and regulatory standards.

Please note that the use of this accessory with an Apple product may affect wireless performance.

Wiring Diagram

- 1 Locate the tractor power/communication harness (006-6650TM(E)).
- 2 At the back of the tractor run the power leads to the battery.
- 3 Connect the red power wire with the 50 amp fuse to the positive side (12 volt) of the battery.
 - a. **The power harness must be connected to the battery!** The unit will draw more amps than convenience outlets can handle. Any modifications of the power harness will void systems warranty. IF MODIFICATIONS ARE REQUIRED CONTACT HARVEST TEC FIRST!
 - b. **This unit will not function on positive ground tractors.**
 - c. **If the unit loses power while operating it will not keep track of accumulated pounds of product used and bale records.**
- 4 Connect the black ground wire to frame of tractor or negative side of (12 volt) battery.
- 5 Connect the iPad integration Control (030-6672C) to the Communication Harness (006-6650TM(E)).
- 6 Connect the orange wires and attach the plug to the tractor's ISOBUS port.
- 7 If using the optional ISOBUS connector (006-6670A) connect the end to the Communication Harness (006-6650TM(E)) in place of the Bluetooth Receiver shown below.
- 8 Connect the orange keyed power wires (006-5650K) to tractor Key Power source.

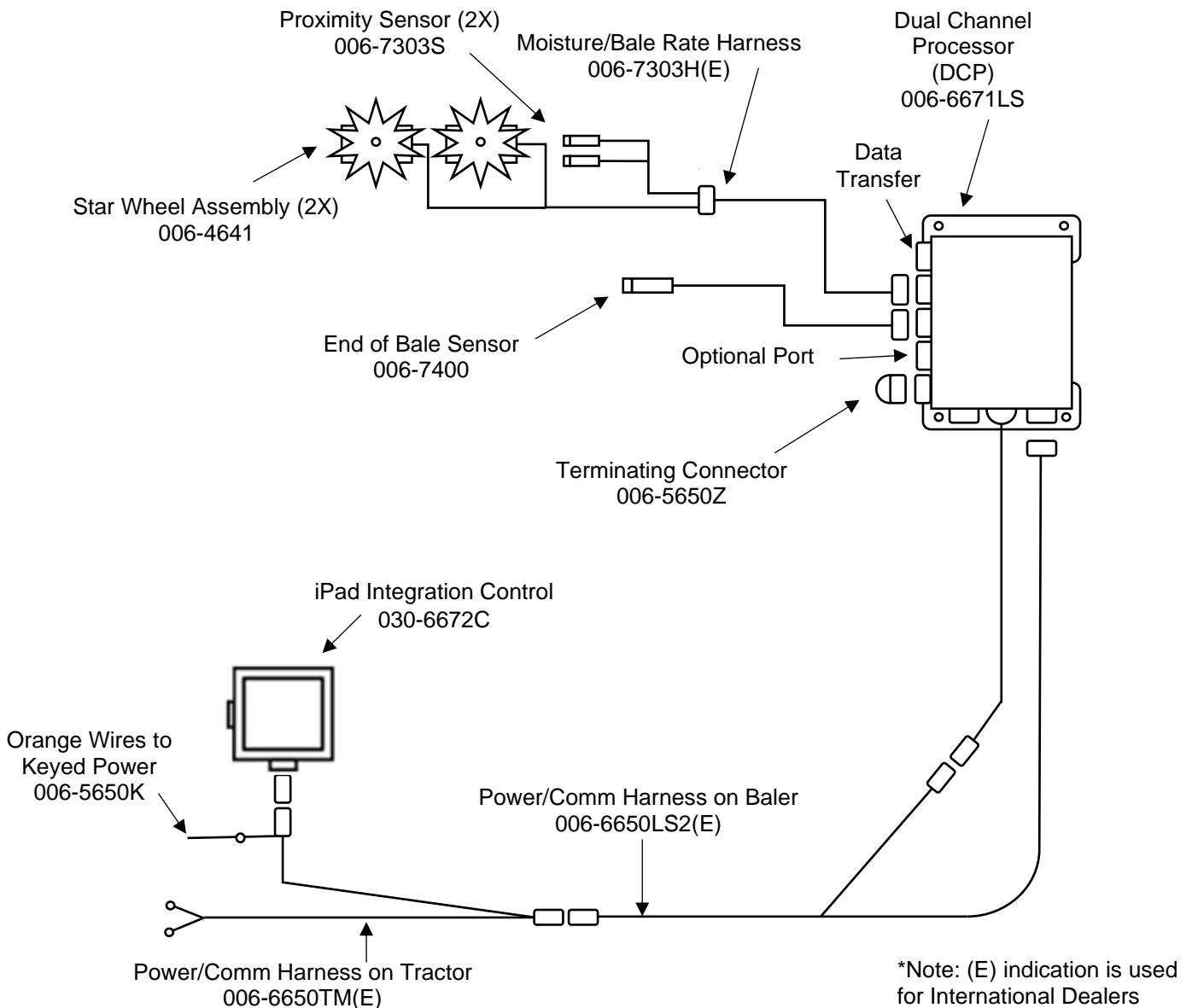

*Claas 3200-3400 balers will have star wheel assembly 030-4642 for mounting on side of bale chamber

Pin Outs

Power/Comm Harness 006-6650TM(E) at Hitch

Pin 1	Red	+12V Power to TSD
Pin 2	Red	+12V Power to DCP
Pin 3	Orange	Keyed Power
Pin 4	Gray	Shield
Pin 5	Green	HT Can Low
Pin 6	Yellow	HT Can Hi
Pin 7	Orange	Can1 Hi
Pin 8	Black	Ground from TSD
Pin 9	Black	Ground from DCP
Pin 10	Blue	Can1 Low

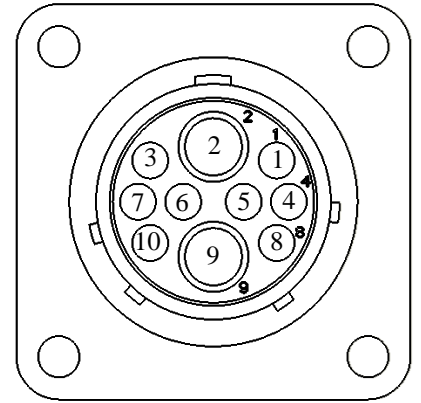

Power/Comm Harness 006-6650LSM2(E) at Hitch

Pin 1	Red	+12V Power to TSD
Pin 2	Red	+12V Power to DCP
Pin 3	Orange	Keyed Power
Pin 4	Gray	Shield
Pin 5	Green	HT Can Low
Pin 6	Yellow	HT Can Hi
Pin 7	Orange	Can1 Hi
Pin 8	Black	Ground from TSD
Pin 9	Black	Ground from DCP
Pin 10	Blue	Can1 Low

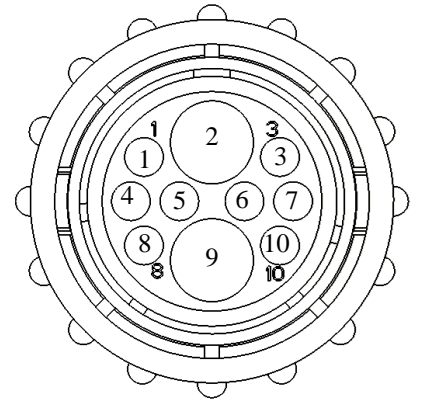

iPad Integration Control / BLE on Harness 006-6650TM(E)

Pin 1	Red	+12V Power from DCP
Pin 2	Black	Ground from TSD
Pin 3	Yellow	HT Can Low
Pin 4	Gray	Shield
Pin 5	Green	HT Can Hi
Pin 6	Orange	Can1 Hi
Pin 7	Blue	Can1 Low

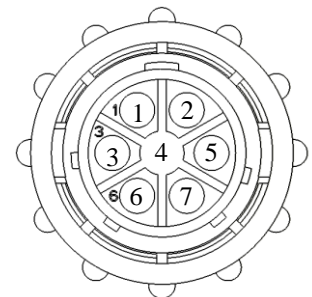

ISOBUS Plug Baler Side

Pin 1	N/A	
Pin 2	N/A	
Pin 3	120 OHM with Pin 5	
Pin 4	N/A	
Pin 5	120 OHM with Pin 3	
Pin 6	Orange	Can1 Hi
Pin 7	Blue	Can1 Low

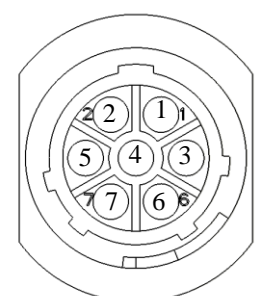

ISOBUS Plug Tractor Side

Pin 1	N/A	
Pin 2	N/A	
Pin 3	+12V Keyed Tractor Power	
Pin 4	N/A	
Pin 5	N/A	
Pin 6	N/A	
Pin 7	N/A	
Pin 8	Orange	Can1 Hi
Pin 9	Blue	Can1 Low

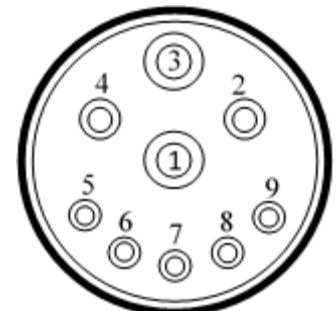

Pin Outs (continued)

Main Power Connector on DCP

Pin 1	Red	+12V Power from tractor
Pin 2	Black	Ground from tractor
Pin 3	Orange	Keyed power

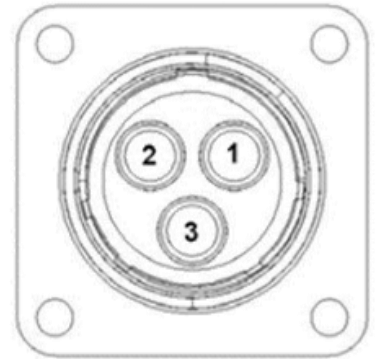

Star Wheel and Bale Rate Sensor connector on DCP

Pin 1	Blue	+12V Power
Pin 2	Orange	Ground
Pin 3	Black	Signal for sensor 1
Pin 4	White	Signal for sensor 2
Pin 5	N/A	
Pin 6	N/A	
Pin 7	N/A	
Pin 8	Violet	Star wheel input 1
Pin 9	Brown	Star wheel input 2



End of Bale sensor on DCP

Pin 1	Brown	Sensor Power
Pin 2	Blue	Sensor Ground
Pin 3	N/A	
Pin 4	Black	Signal from Sensor

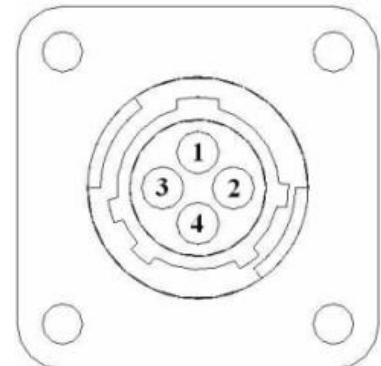

Troubleshooting

PROBLEM	POSSIBLE CAUSE	SOLUTION
Moisture reading errors (high or low)	1. Wire disconnected or bad connection between star wheels and DCP	1. Reconnect wire.
	2. Low power supply to DCP	2. Check voltage at box. (Min of 12 volts required.) See Diagnostics section of manual.
	3. Dry hay lower than 8% moisture or wet hay over 75%.	3. System reads 8-70% moisture.
	4. Ground contact with one or both star wheels and baler mounted processor.	4. Reconnect.
	5. Short in wire between star wheels and DCP.	5. Replace wire.
	6. Check hay with hand tester to verify.	6. Contact Harvest Tec if conditions persist.
Moisture readings erratic.	1. Test bales with hand tester to verify that DCP has more variation than hand tester.	
	2. Check all wiring connections for corrosion or poor contact.	2. Apply dielectric grease to all connections.
	3. Check power supply at tractor. Voltage should be constant between 12 and 14 volts.	3. Install voltage surge protection on tractors alternator.
Terminal reads under or over power.	1. Verify with multi-meter actual voltage. Voltage range should be between 12-14 volts.	1. Clean connections and make sure applicator is hooked to battery. See Diagnostics section of manual.
Bale rate displays zero.	1. Bale rate sensors are reversed. 2. Short in cable. 3. Damaged sensor. 4. Sensor too far from starwheel.	1. Switch the sensors next to the star wheel. 2. Replace cable. 3. Replace sensor. 4. Adjust gap between prox sensor and star wheel so it is 1/8-1/4" away.
Bluetooth Receiver lights will not illuminate	1. Bluetooth receiver not connected 2. Harness disconnected 3. Low power	1. Check connections and voltage. Minimum 12.5V needed.
	<p><i>Blinking Lights</i> – System is waiting for the processor to connect, which could take up to 35 seconds.</p> <p><i>Red Light</i> – The Bluetooth receiver has power</p> <p><i>Green Light</i> – When the proper active connection is selected in the Hay App menu, the green light will indicate connection with the iPad.</p>	

Parts Breakdown for Star Wheel Moisture Sensors

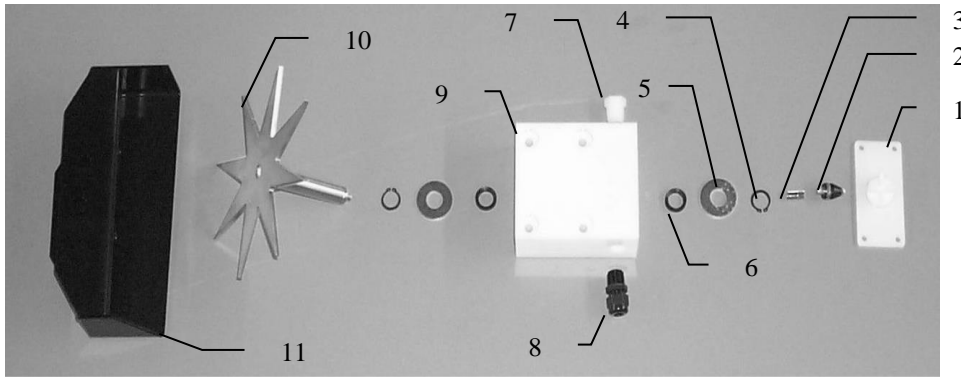

<u>Ref</u>	<u>Description</u>	<u>Part#</u>	<u>Qty</u>	<u>Ref</u>	<u>Description</u>	<u>Part#</u>	<u>Qty</u>
1.	Block cover	006-4641B	2	9.	Star wheel block	006-4641A	2
2.	Electronic swivel	006-4642A	2	10.	Star wheel sensor	030-4641C	2
3.	Swivel insert	w/ Ref # 10	2	11.	Twine guard-left	001-4645	1
4.	Snap ring (per side)	006-4641K	2		Twine guard-right (prox)	001-4644	1
5.	Washer (per side)	w/006-4641K	2				1
6.	Dust seal (per side)	w/006-4641K	2				1
7.	Plug fitting	003-F38	2	1-10	Star wheel assembly	030-4641	2
8.	Wiring grommet	008-0821A	2				1

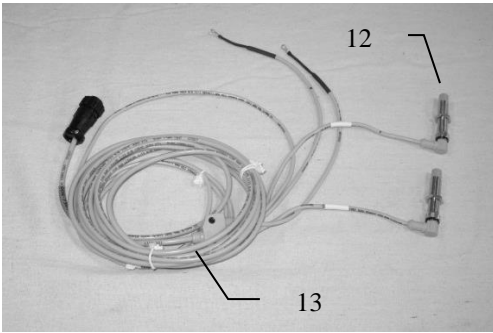

<u>Ref</u>	<u>Description</u>	<u>Part#</u>	<u>Qty</u>
12	Bale rate sensor	006-7303S	2
13	Moisture and bale rate harness	006-7303H(E)	1

*Note: (E) indication is used for International Dealers

Vicon, Kuhn, Claas 3200-3400 balers

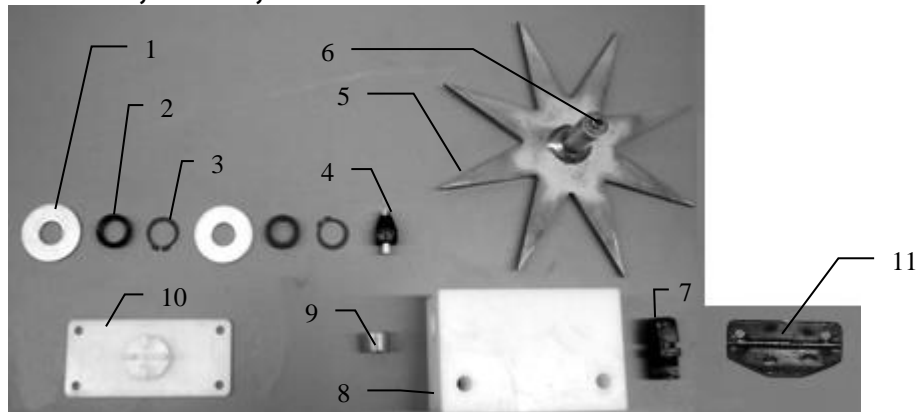

<u>Ref</u>	<u>Description</u>	<u>Part#</u>	<u>Qty</u>	<u>Ref</u>	<u>Description</u>	<u>Part#</u>	<u>Qty</u>
1	Washer (per side)	006-4642K	2	7	Wiring grommet	008-0821A	2
2	Dust Seal (per side)	w/006-4642K	1	8	Star wheel block	006-4641A	2
3	Snap Ring (per side)	w/006-4642K	2	9	Plug Fitting	003-F38	2
4	Swivel	006-4642A	2	10	Block Cover	006-4641B	2
5	Star Wheel	030-4641E	2	1-10	Star wheel assembly	030-4642	2
6	Insert	w/ Ref # 5	2	11	Prox Sensor Holder	001-4644SS	1

Parts Breakdown for 600 Series Control and Harnesses

Dual Channel Processor (DCP)



<u>Ref</u>	<u>Description</u>	<u>Part Number</u>	<u>Qty</u>
1	Dust Plugs	006-5651PLUGS	1
2	End of Bale Sensor 600 Series	006-7400	1
3a	Hesston 4755, 4910 EOB Mount	001-4648H	1
3b	EOB Bracket CLAAS 3300	001-4648C	1
3c	Krone EOB Bracket	001-4648K	1
3d	EOB BKT Krone 12130	001-4648K2	1
3e	End of Bale Sensor Bracket	001-4948	1
4	DCP Shield Cover	001-5650X	1
5	DCP Main Control LS 600 AUTO	006-6671LS	1
6	Terminating Connector w/ Green Cap	006-5650Z	1
7	DCP Baler Harness 30'	006-6650LS2(E)	1
8	DCP Tractor Harness	006-6650TM(E)	1
9	Optional ISOBUS Tractor Plug (not included)	006-6670A	1
10	Key Switch Wire	006-5650K	1
11	iPad Integration Control	030-6672C	1
NP	USB Cord	006-6672USBC	



*Note: (E) indication is used for International Dealers

Optional iPad Mini Mounting Kit (030-2014MK)

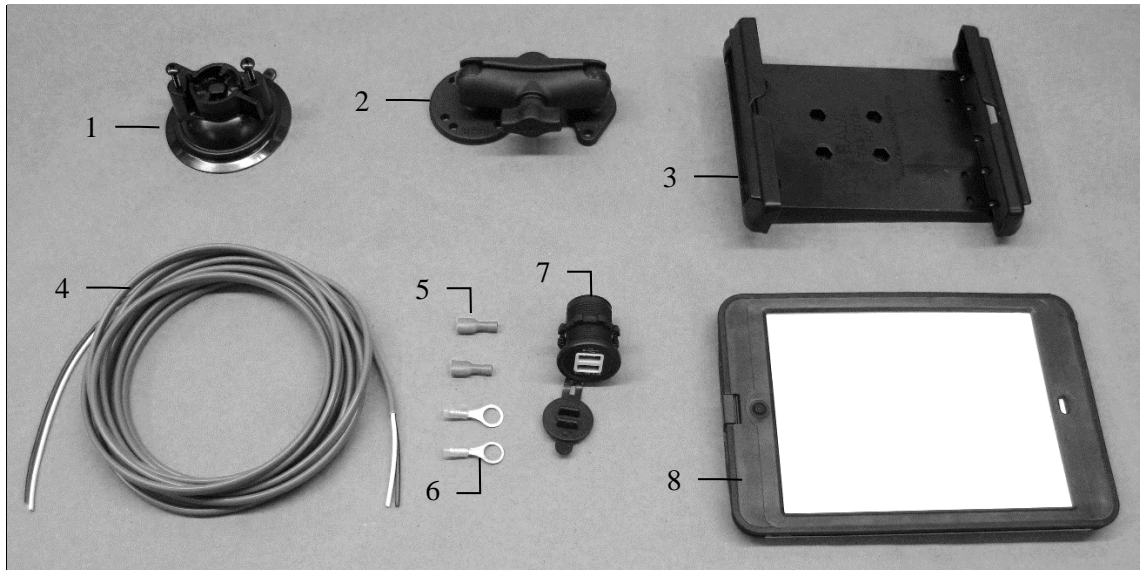

<u>Ref</u>	<u>Description</u>	<u>Part #</u>	<u>Qty</u>
1	Suction cup mount	001-2012SCM	1
2	Ram mount	001-2012H	1
3	iPad Mini® spring load cradle (Mini 4)	001-2012SLC	1
4	16 gauge power wire	006-4723P	1
5	Female spade connector	Hardware	2
6	Eye loop connector	Hardware	2
7	iPad Mini Charger 12V	001-2012P	1
8	iPad Mini 4 case	001-2012C4	1
NP	4 amp fuse	Hardware	1
Mounting Kit Assembly		030-2014MK (Includes All Parts)	

Installation Instructions

1. Identify 12V power source for wires to connect.
 - a. Eye loops included if wiring directly to the battery is desired.
 - b. Test for key power source if preferred to have power to the USB shut off with the key.
2. Once power source is identified, cut wires to desired length.
3. Crimp the two supplied quick connectors onto each the white and black wire.
4. Remove the round locking plastic nut from USB plug before connecting the wires. Black (+) White (-).
5. The wires will then be hooked to the designated terminals on the bottom of the USB plug
6. Drill a 1 1/8" hole in the preferred mounting location. Be sure to clean any sharp edges after drilling.
7. Feed the wires through the mounting hole.
8. If using the round plastic nut to secure plug in place, slide the nut back over the wiring before connecting the wires to powered source.
9. Connect the wires to the identified power source if easier to do so before tightening the plug into place.
10. Tighten plug using either the round plastic nut or mounting plate and two screws, both options supplied.
11. Once connected, hook a USB charging cord into the plug and connect a mobile device/tablet to ensure the plug is operating as you wish (key power working properly if necessary).

NOTE: This plug is not designed to charge two iPads. System damage could occur if this is attempted. System will charge a mobile phone and iPad simultaneously without problem.

*iPad mini is a trademark of Apple Inc., registered in the U.S. and other countries.

Optional iPad Display Kit (030-4670DK)

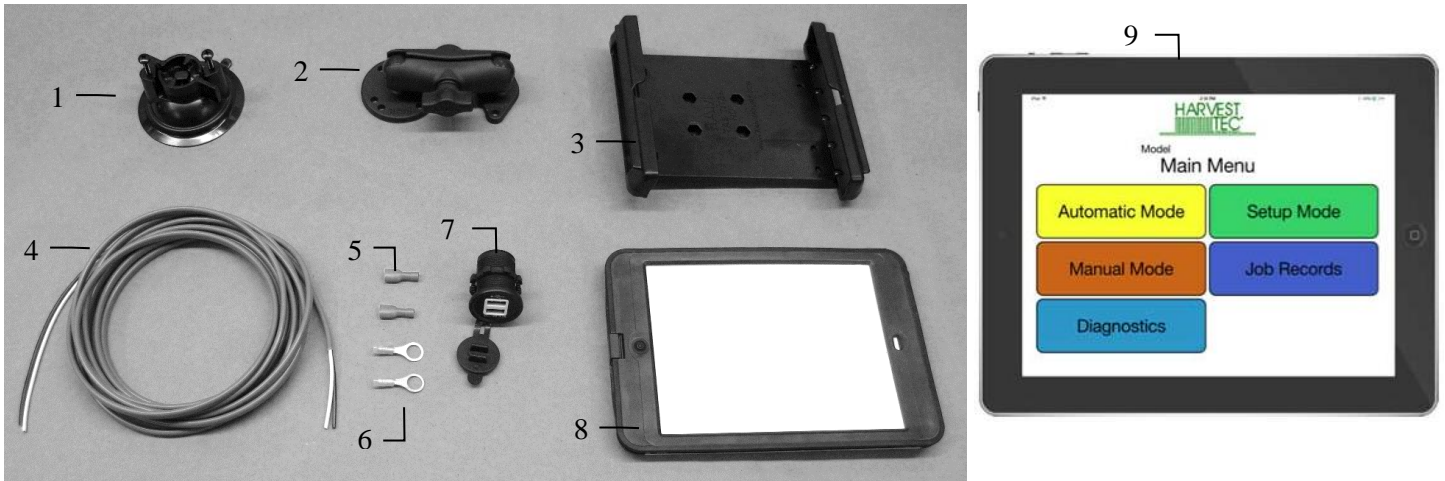

Ref	Description	Part #	Qty	Ref	Description	Part #	Qty
1	Suction cup mount	001-2012SCM	1	7	iPad Mini Charger 12V	001-2012P	1
2	Ram mount	001-2012H	1	8	iPad Mini 4 case	001-2012C4	1
3	iPad Mini® spring load cradle (Mini 4)	001-2012SLC	1	9	iPad Mini 4	006-4670IP	1
4	16 gauge power wire	006-4723P	1	NP	4 amp fuse	Hardware	1
5	Female spade connector	Hardware	2				
6	Eye loop connector	Hardware	2				
					Mounting Kit Assembly	030-4670DK (Includes All Parts)	

Installation Instructions

1. Identify 12V power source for wires to connect.
 - a. Eye loops included if wiring directly to the battery is desired.
 - b. Test for key power source if preferred to have power to the USB shut off with the key.
2. Once power source is identified, cut wires to desired length.
3. Crimp the two supplied quick connectors onto the white and black wire.
4. Remove the round locking plastic nut from USB plug before connecting the wires. Black (+) White (-).
5. The wires will then be hooked to the designated terminals on the bottom of the USB plug
6. Drill a 1 1/8" hole in the preferred mounting location. Be sure to clean any sharp edges after drilling.
7. Feed the wires through the mounting hole.
8. If using the round plastic nut to secure plug in place, slide the nut back over the wiring before connecting the wires to powered source.
9. Connect the wires to the identified power source if easier to do so before tightening the plug into place.
10. Tighten plug using either the round plastic nut or mounting plate and two screws, both options supplied.
11. Once connected, hook a USB charging cord into the plug and connect a mobile device/tablet to ensure the plug is operating as you wish (key power working properly if necessary).

NOTE: This plug is not designed to charge two iPads. System damage could occur if this is attempted. System will charge a mobile phone and iPad simultaneously without problem.

*iPad mini is a trademark of Apple Inc., registered in the U.S. and other countries.

Star Wheel Installation Template

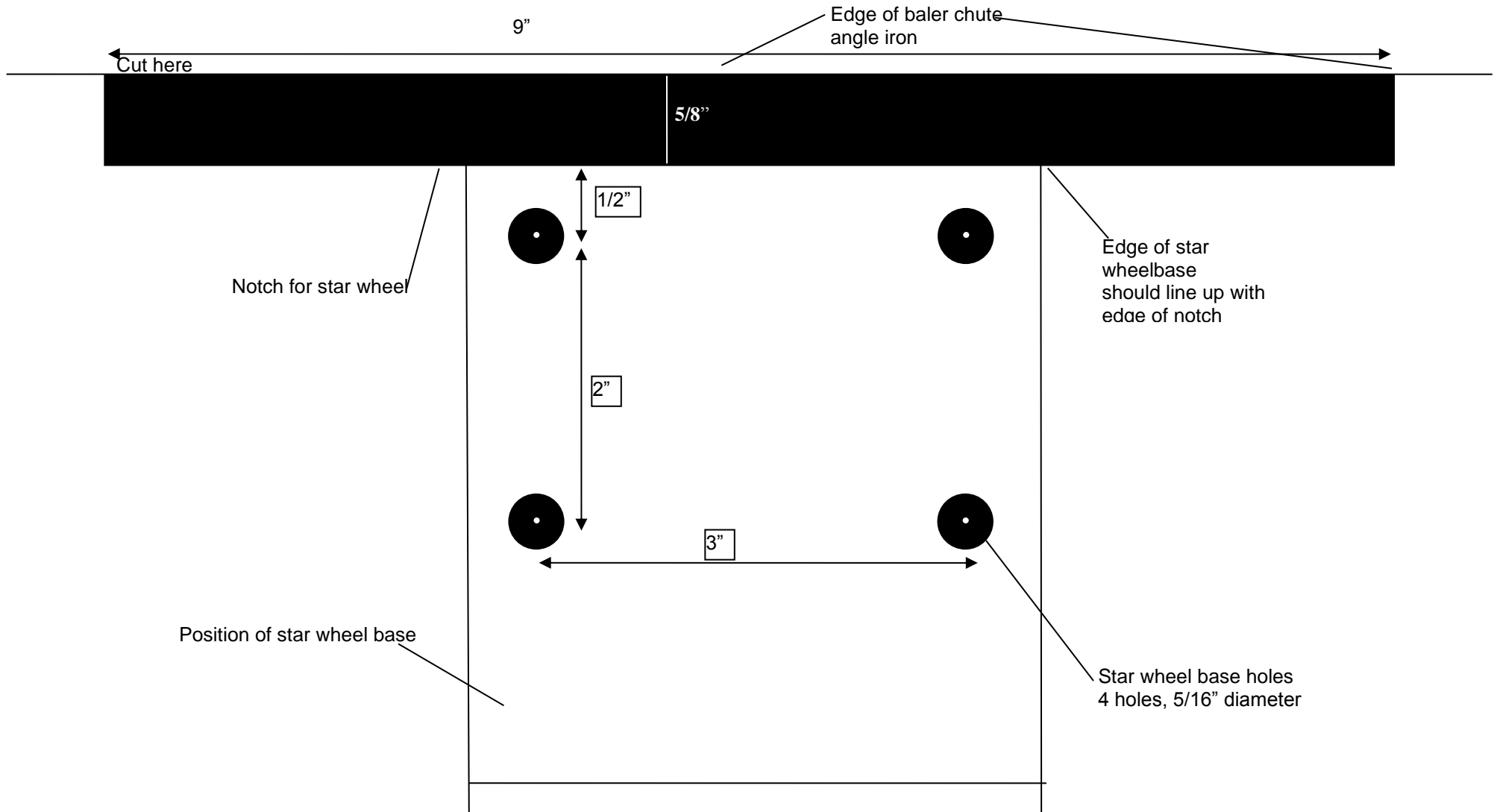

This guide is to be used as a visual aid for star wheel installation. Exact measurements on baler are determined by operator

Notes

Notes

Harvest Tec Inc. Warranty and Liability Agreement

Harvest Tec, Inc. will repair or replace components that are found to be defective within 12 months from the date of manufacture. Under no circumstances does this warranty cover any components which in the opinion of Harvest Tec, Inc. have been subjected to negligent use, misuse, alteration, accident, or if repairs have been made with parts other than those manufactured and obtainable from Harvest Tec, Inc.

Our obligation under this warranty is limited to repairing or replacing free of charge to the original purchaser any part that in our judgment shows evidence of defective or improper workmanship, provided the part is returned to Harvest Tec, Inc. within 30 days of the failure. If it is determined that a non-Harvest Tec branded hay preservative has been used inside the Harvest Tec applicator system where the failure occurred, then Harvest Tec reserves the right to deny the warranty request at their discretion. Parts must be returned through the selling dealer and distributor, transportation charges prepaid.

This warranty shall not be interpreted to render Harvest Tec, Inc. liable for injury or damages of any kind, direct, consequential, or contingent, to persons or property. Furthermore, this warranty does not extend to loss of crop, losses caused by delays or any expense prospective profits or for any other reason. Harvest Tec, Inc. shall not be liable for any recovery greater in amount than the cost or repair of defects in workmanship.

There are no warranties, either expressed or implied, of merchantability or fitness for particular purpose intended or fitness for any other reason.

This warranty cannot guarantee that existing conditions beyond the control of Harvest Tec, Inc. will not affect our ability to obtain materials or manufacture necessary replacement parts.

Harvest Tec, Inc. reserves the right to make design changes, improve design, or change specifications, at any time without any contingent obligation to purchasers of machines and parts previously sold.

Revised 4/17

HARVEST TEC, INC.
P.O. BOX 63
2821 HARVEY STREET
HUDSON, WI 54016
PHONE: 715-386-9100
1-800-635-7468
FAX: 715-381-1792
Email: info@harvesttec.com