

# Operation Manual

***Model 600A & 600UHD***

***Moisture Sensor Kit for Large Square Balers***



**HayBoss™**  
**G2**

## DECLARATION OF INCORPORATION



**MANUFACTURER:**

Harvest Tec Inc.  
2821 Harvey St.  
P.O. Box 63  
Hudson, WI 54016, U.S.A.

**REPRESENTATIVE ESTABLISHED IN COMMUNITY:** Profitable Farming Company  
Middle Barlington, Roborough  
Winkleigh, Devon, EX19 8AG  
ENGLAND

The person above certifies and declares that:

**VIRTUAL MACHINE:** Equipment mounted on a farm press and for the application of inoculants onto forage crops.

**MODEL:** 600A & 600UHD-16-OPR-Imp&Metric

**BRAND:** Harvest Tec

**SERIAL NUMBER:**

This application preservatives for hay Harvest Tec system meets the Directive 2006/42/EC of the European Parliament and the Council of 17 May 2006 and other applicable European Directives including Directive 2004/108/EC on the Electromagnetic compatability.

The application of preservatives for hay Harvest Tec system will be turned on after being installed on a farm press has been declard in conformity with the Machinery Directive.

Person in the community authorized to provide information on the partly completed machinery and making this statement:

**Richard Snell, President, Profitable Farming Company**  
Signed on May 21, 2011: Middle Barlington, Roborough  
Winkleigh, Devon, EX19 8AG  
ENGLAND

# Operations Manual Table of Contents

	<b><u>PAGE</u></b>
<b>Introduction</b>	<b>4</b>
<b>System Requirements</b>	<b>4</b>
<b>Safety</b>	<b>4</b>
<b>Safety Decals</b>	<b>4</b>
<b>Operation of the 600A Moisture Sensor Kit</b>	<b>5-11</b>
Operations of the ISOBUS Monitor	5
<b>Baler Monitor Setup</b>	<b>5</b>
System Setup	6-8
Adjust the Moisture Alarm	9
Option To Turn OFF/ON All Alarms or Beeps	10
Baler Monitor Setup / View – UHD Baler Only	11
<b>Wiring Diagram</b>	<b>12</b>
<b>Pin Outs</b>	<b>13-14</b>
<b>Common Questions</b>	<b>15</b>
<b>Troubleshooting</b>	<b>16</b>
<b>Parts Breakdown</b>	<b>17-18</b>
Star Wheels and Bale Rate Sensors	17
Controls and Harnesses	18
<b>Warranty</b>	<b>19</b>

## Introduction

Thank you for purchasing a Harvest Tec moisture monitor system. This moisture monitoring system has been designed to be operated through the baler's ISOBUS system and/or an Apple iPad (not included) using the Hay App. The unit offers these advantages:

1. Operation coordinated with baler operation
2. Less cab clutter providing better visibility
3. Ease of use with all information on one screen
4. Records kept together

The kit includes the following parts: Dual Channel Processor (DCP), Moisture Sensors, Harnesses, Bluetooth receiver and Miscellaneous Hardware. For your convenience a parts break down for the 600A Moisture Monitoring System is included in the back of this manual. If you do have questions please bring this manual into the dealership. They can assist you in ordering the correct replacement parts.



Right and Left sides are determined by facing in the direction of forward travel.

***\*iPad Mini or iPad 3rd Generation (2012) or newer, running the current iOS operating system or one version previous required for iPad option.***

**\*\*600 Series Applicators with serial number before DCP27000 will require the DCP to be sent to Harvest Tec for a required update in order to use the iPad Integration Module (030-6670C).**

\*Hay App version must be **at least 2.5.18 (or higher)** to operate with the iPad Integration Module (030-6672C)

## System Requirements

 **The Baler Processor must have Version 3.3 or higher.**   
**C1000 monitor must have Version 3.0.1 or higher**  
**If equipped with the SBM, the SBM must have Version 4.0 or higher.**

**\*Requirement to run iPad option are 3<sup>rd</sup> Generation iPad (2012) or newer with iOS8 or greater operating system, plus the Hay App.**

## Safety

Carefully read all safety signs in this manual and on the moisture sensor kit before use. Keep signs clean and clear of obstruction to view. Replace missing or damaged safety signs. Replacement signs are available from your local authorized dealer. See your installation manual under the replacement parts section for the correct part numbers.

Keep your moisture sensor kit in proper working condition. Unauthorized modifications to the moisture sensor kit may impair the function and/or safety of the machine.

## Safety Decals

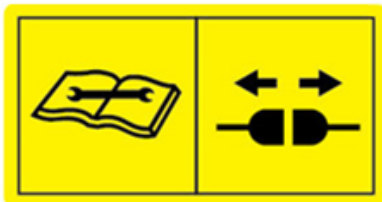

Number 1  
Disconnect power before servicing.  
Part no. DCL-8003



Number 2  
Read and understand the operator's manual before using or working around the equipment.  
Part no. DCL-8000

## Operation of 600A Moisture Sensor Kit

## Operation of the ISOBUS Monitor

The ISOBUS Monitor utilizes a combination of soft keys, number menus, and the scroll wheel on the upper right side of the actual monitor to make selections. Selections are made by scrolling the Thumb Wheel and pressing in once the selection is highlighted. All buttons are labeled and color coded.



## Baler Monitor Setup

After the initial Start Up/Power On the green “uploading data” status bar (arrow A) should begin to fill.

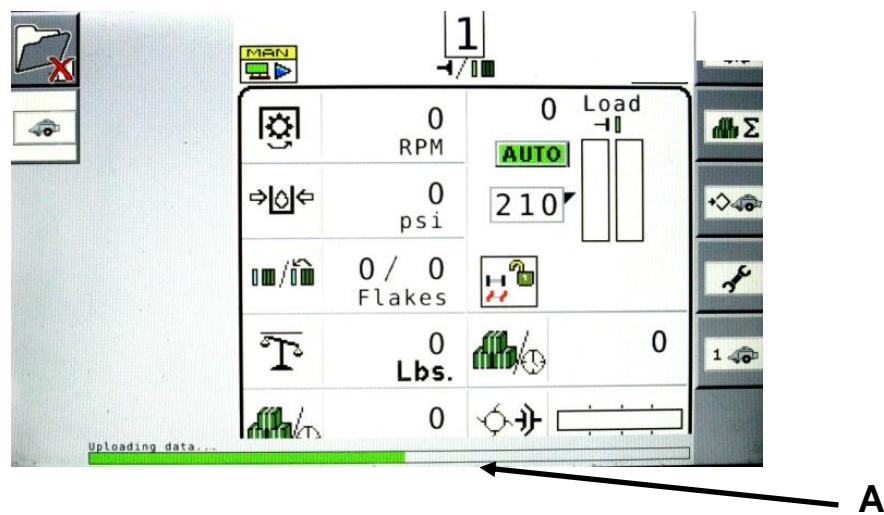

## System Setup

- To view moisture from the 600A Moisture Sensor begin setup at the main baler screen. Select the **WRENCH** icon (arrow A) which is the fourth icon down on the right side of the screen-the right menu.

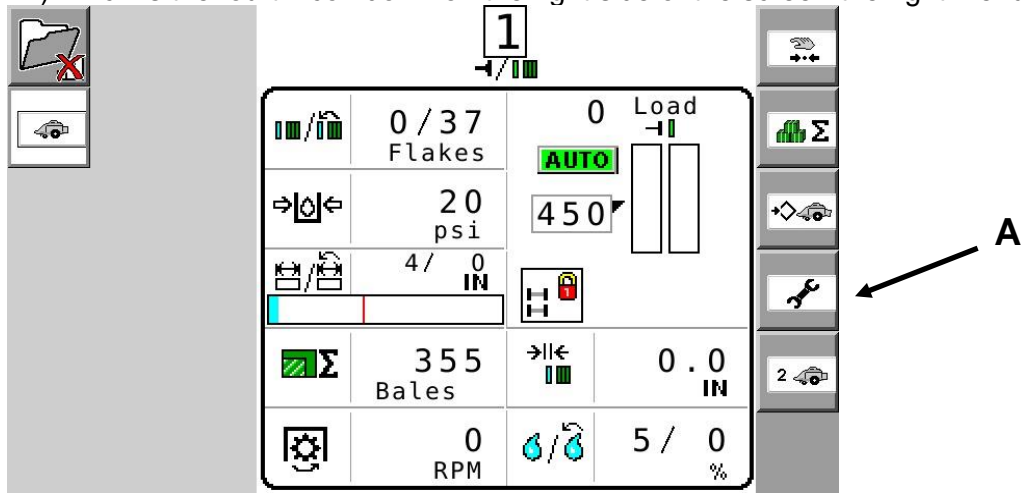

- The service screen displayed below should appear. Select the **Next Screen** icon (arrow B) located at the bottom of the right selection menu.

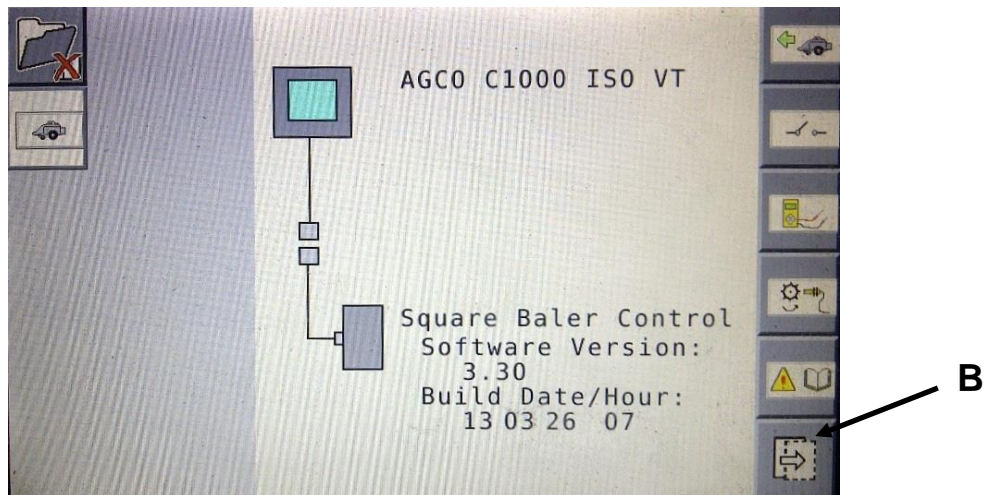

- A similar screen will appear with a different menu options on the right side of the screen. Press the **A B C** icon (arrow C) located at the top right of the selection menu.

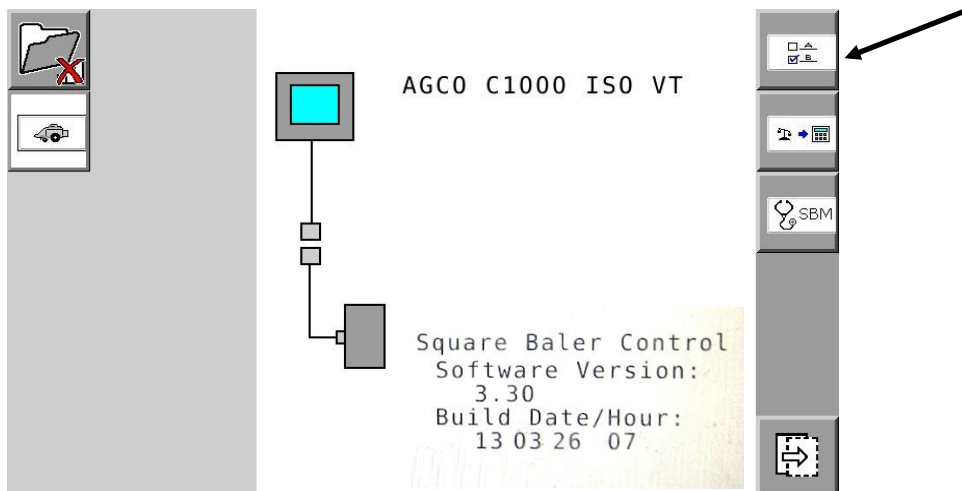

4. The A B screen will appear. Next select the **A B 2** (arrow D) icon which is the second from the top on the far right selection menu.

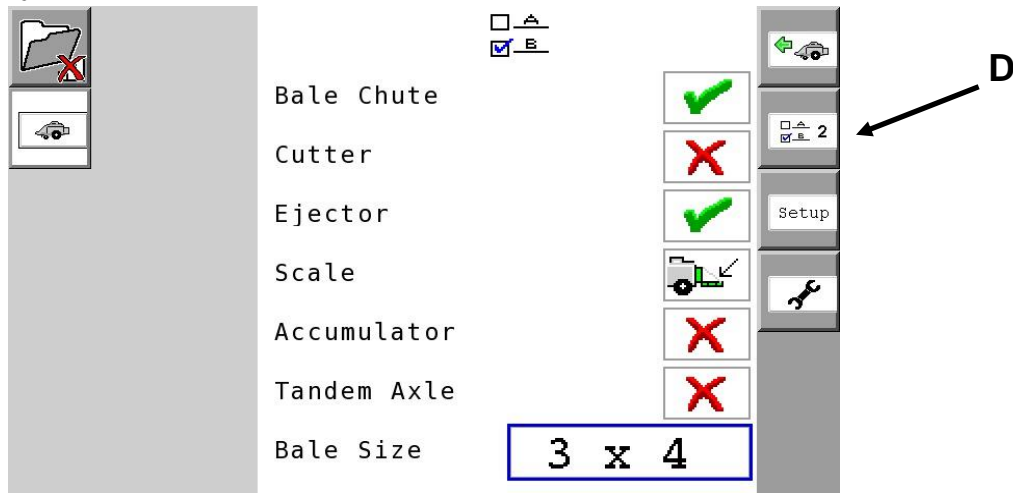

5. The A B 2 screen will appear. The **Harvest Tec** On/Off selection icon can now be selected. To turn the Harvest Tec Moisture Sensor On (signified by a **green check mark**) or Off (signified by a **red X**) navigate to the box and select (arrow E) by pressing the **Scroll Wheel**. Once the Harvest Tec Moisture Sensor has been turned On/Off you can navigate back to the main baler work screen by pressing the **BALER** (arrow F) icon on the top right of the selection menu.

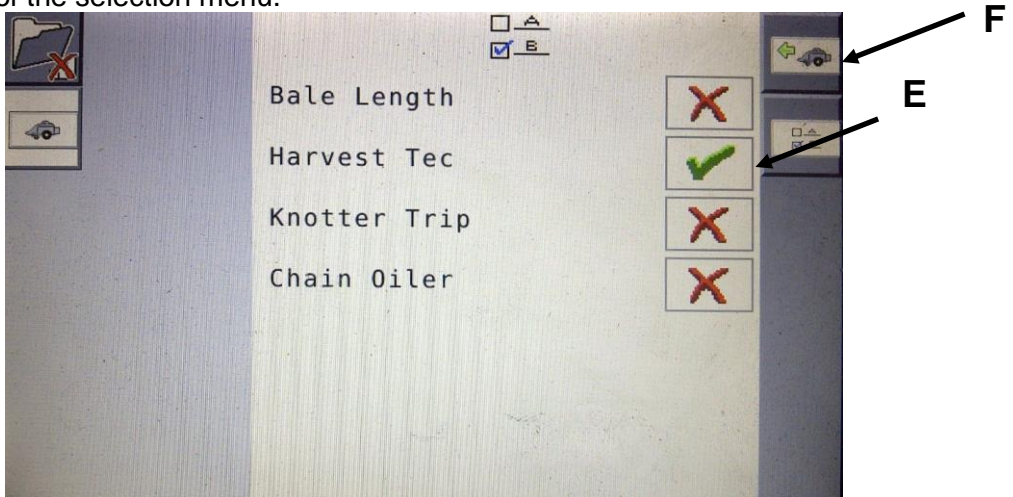

6. The main baler work screen will appear. Select the **container** (arrow G) where you would like to view the moisture information on the baler run screen. *Note: This can be done on the primary or secondary baler work screen. The screen has been or can be customized for viewing containers or options as you would like and as guided in the baler manual.*

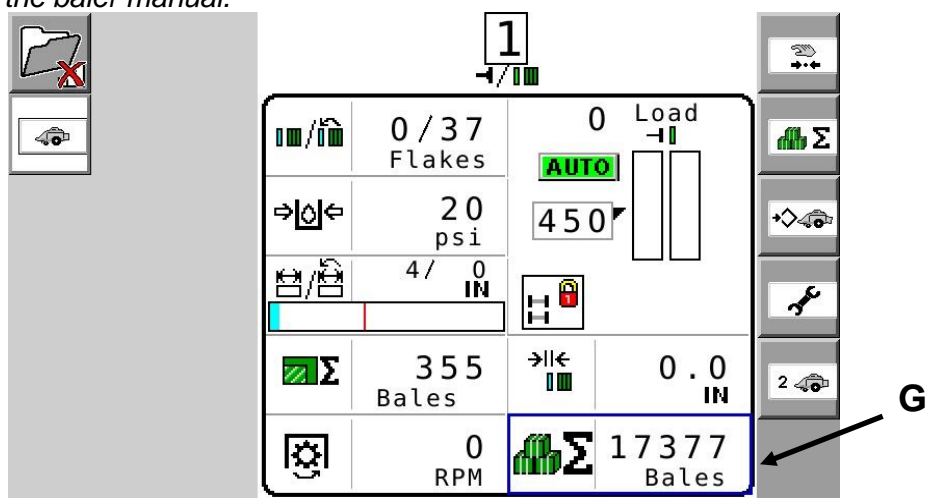

7. Once the user has selected the container they would like to change, a **drop down list** (arrow H) will appear. The **Moisture option** (arrow I) should be at the bottom of the drop down selection list.

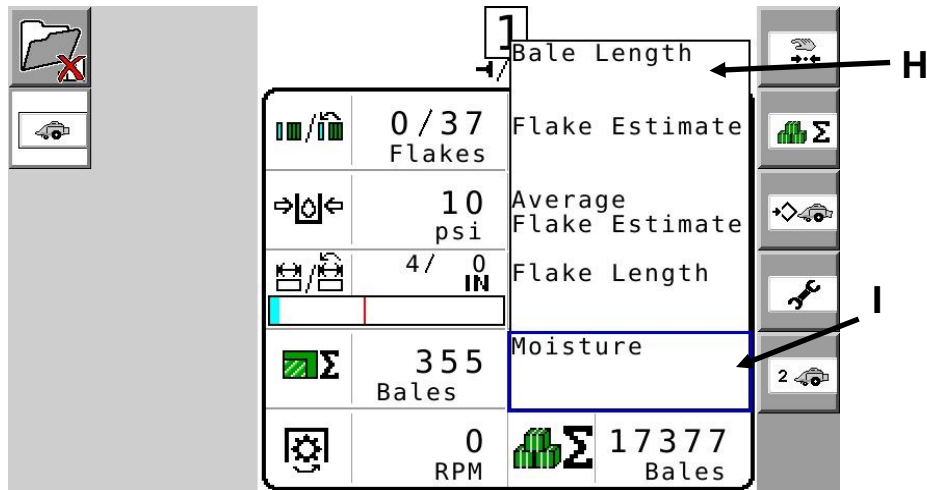

8. The Moisture container will have a red background until HayBoss G2 system is put in Manual Mode or Auto Mode. The two values indicated in the moisture option are as follows: **current moisture / last bale average moisture** (arrow J).

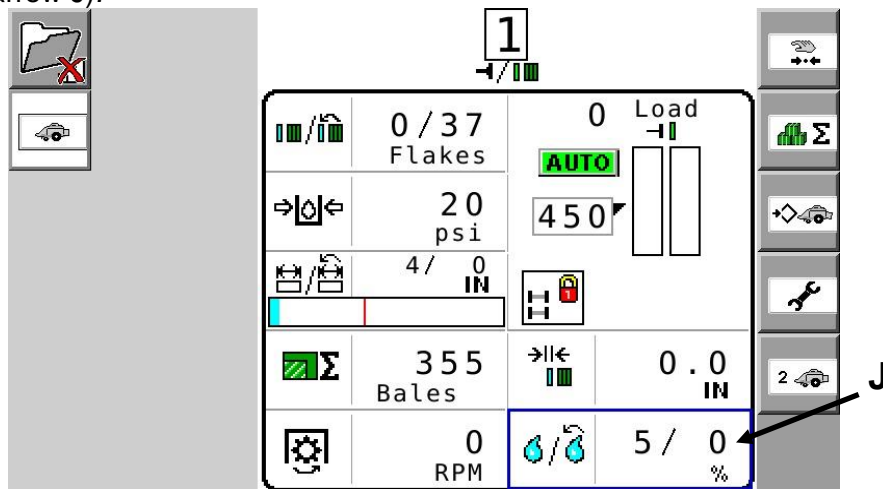



## Adjust the Moisture Alarm

- From the main baler screen, select the third icon down the right selection menu that shows a **diamond beside a baler** (arrow K).

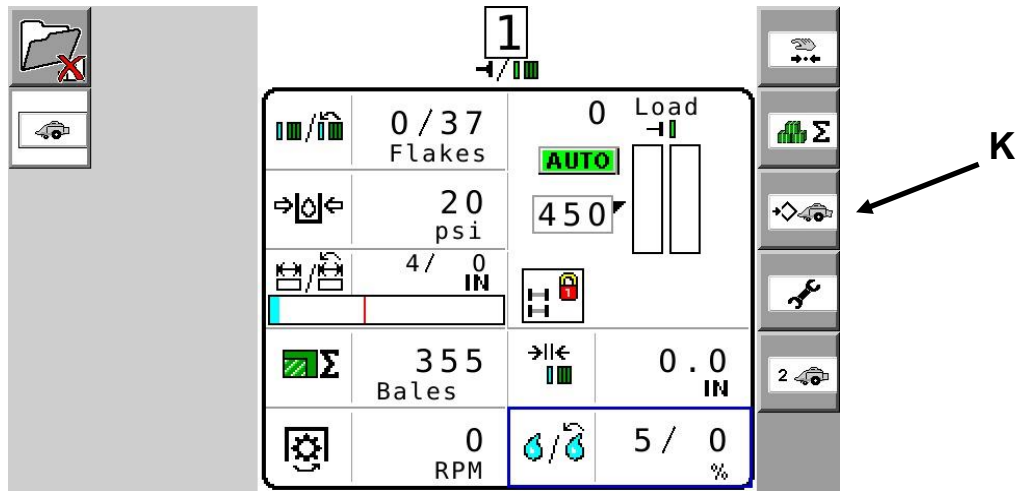

- To adjust the moisture alarm set point select the **box option to the right of the moisture droplets** (arrow L) and adjust to the desired moisture limit. To return to the baler work screen, press the baler icon at the top right of the selection menu (arrow M). When the moisture is higher than the alarm setting the audible alarm will sound (if turned on) and the moisture values on the screen will display with a red background.

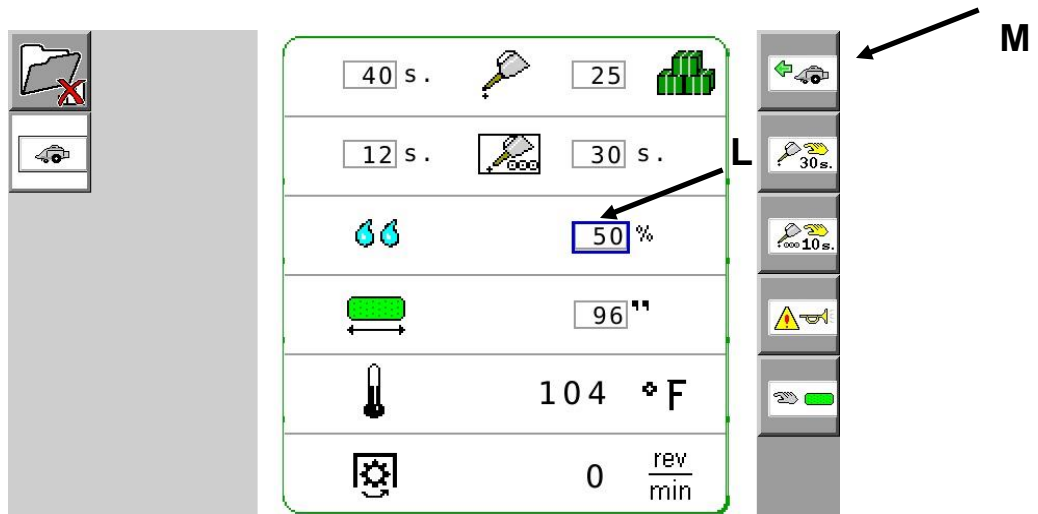

## Option to turn Off/On all Alarms or Beeps

- From the main baler work screen select the third icon down the right selection menu that shows a **diamond beside a baler** (arrow N).

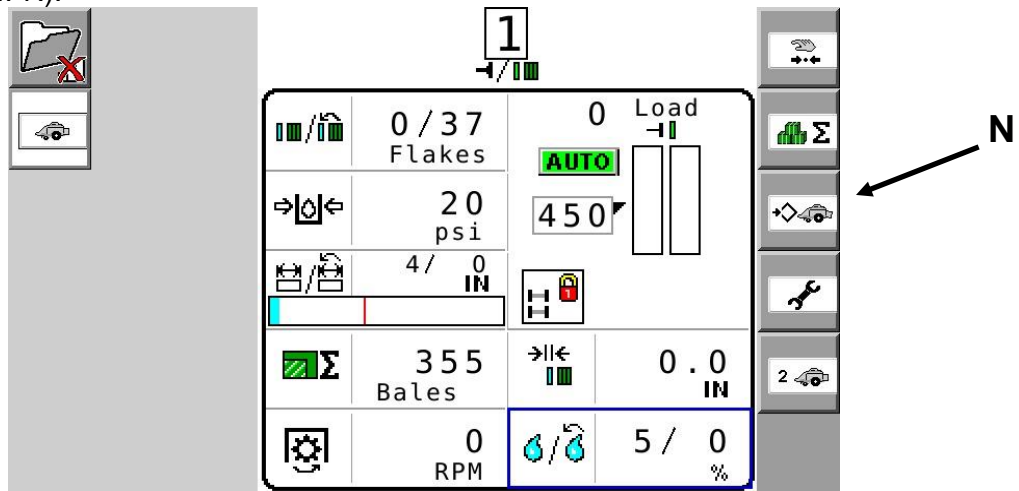

- Select the fourth icon on the right selection menu showing a **bugle beside an alarm** icon (arrow O).

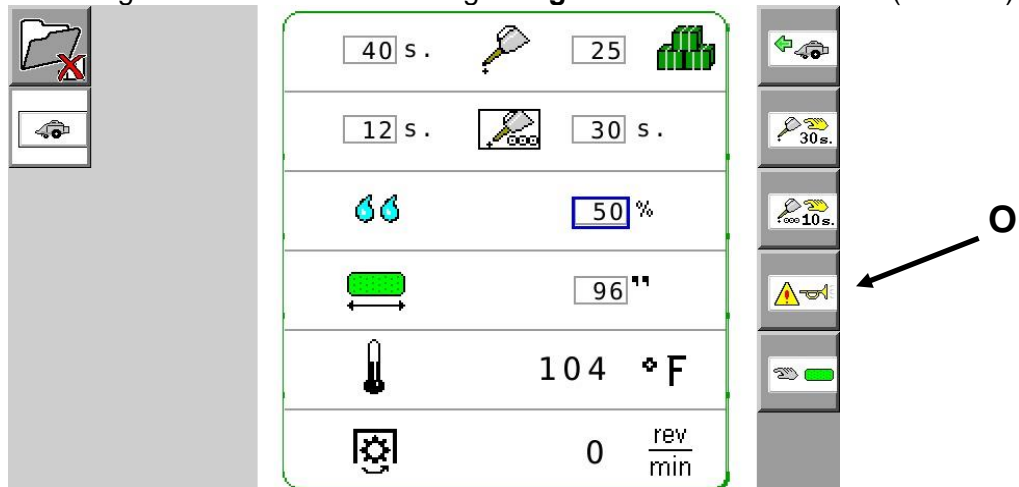

- The alarm screen will now be displayed. All alarms can be silenced before they are ever heard. This can be done by selecting the **Peak Moisture** icon (arrow P) and turning the alarm On/Off. To return to the baler work screen, press the baler icon located at the top right of the selection menu. If the moisture is higher than the alarm setting the moisture values will be displayed with a red background but there will be no audible alarm if this is turned off.



Please refer to the baler service manual for software updates.

# Baler Monitor Setup / View – UHD Baler Only

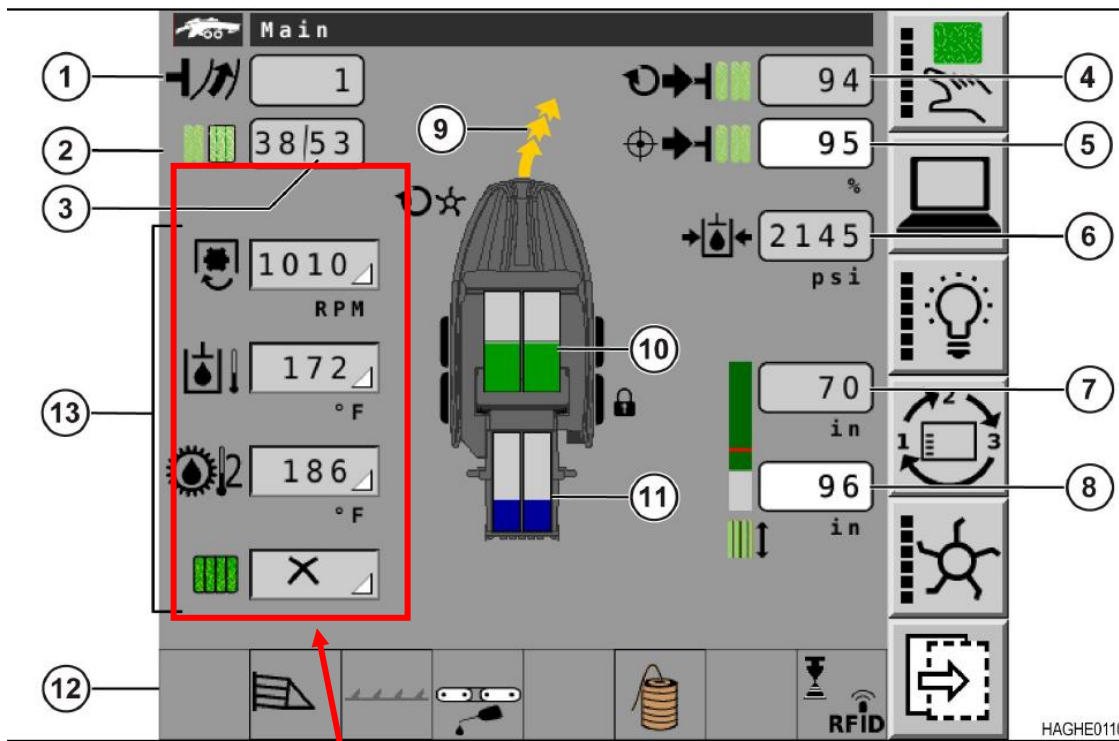

These four containers can be configured by the operator. In the selectable list are the items for your system. They are Current moisture, average moisture, applicator target rate, and applicator actual rate. When moisture is above your alarm setpoint it will show the moisture value with a red background.

This container is reserved for the moistures system. It shows the tagger status and applicator status. When moisture is above your setpoint it will turn the background red and show the percent moisture icon in the upper right corner.

Background turns red when your system is on main work screen. Icon Blinks when the system is paused.

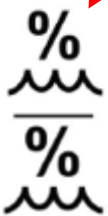

Current Moisture

Average Moisture



Preservative Applicator Target Rate

Preservative Applicator Actual Rate



Moisture System On. The icon will flash when the system is paused

Moisture System Off



Tagger Installed and On. This icon will flash when a tag is applied. There is also a % symbol that shows in the top right corner if the bale moisture goes over the limit

## Wiring Diagram

- 1 Locate the tractor power/communication harness (006-6650TM(E)).
- 2 At the back of the tractor run the power leads to the battery.
- 3 Connect the red power wire with the 50 amp fuse to the positive side (12 volt) of the battery.
  - a. **The power harness must be connected to the battery!** The unit will draw more amps than convenience outlets can handle. Any modifications of the power harness will void systems warranty. IF MODIFICATIONS ARE REQUIRED CONTACT HARVEST TEC FIRST!
  - b. **This unit will not function on positive ground tractors.**
  - c. **If the unit loses power while operating it will not keep track of accumulated pounds of product used and bale records.**
- 4 Connect the black ground wire to frame of tractor or negative side of (12 volt) battery.
- 5 Connect the iPad Integration Control (030-6672C) to the Communication Harness (006-6650TM(E)).
- 6 Connect the orange wires and attach the plug to the tractor's ISOBUS port.
- 7 Connect the end to the Communication Harness (006-6650TM(E)) to the iPad Integration Control.
- 8 Connect the orange keyed power wires (006-5650K) and attach the plug to the tractor's ISOBUS port.

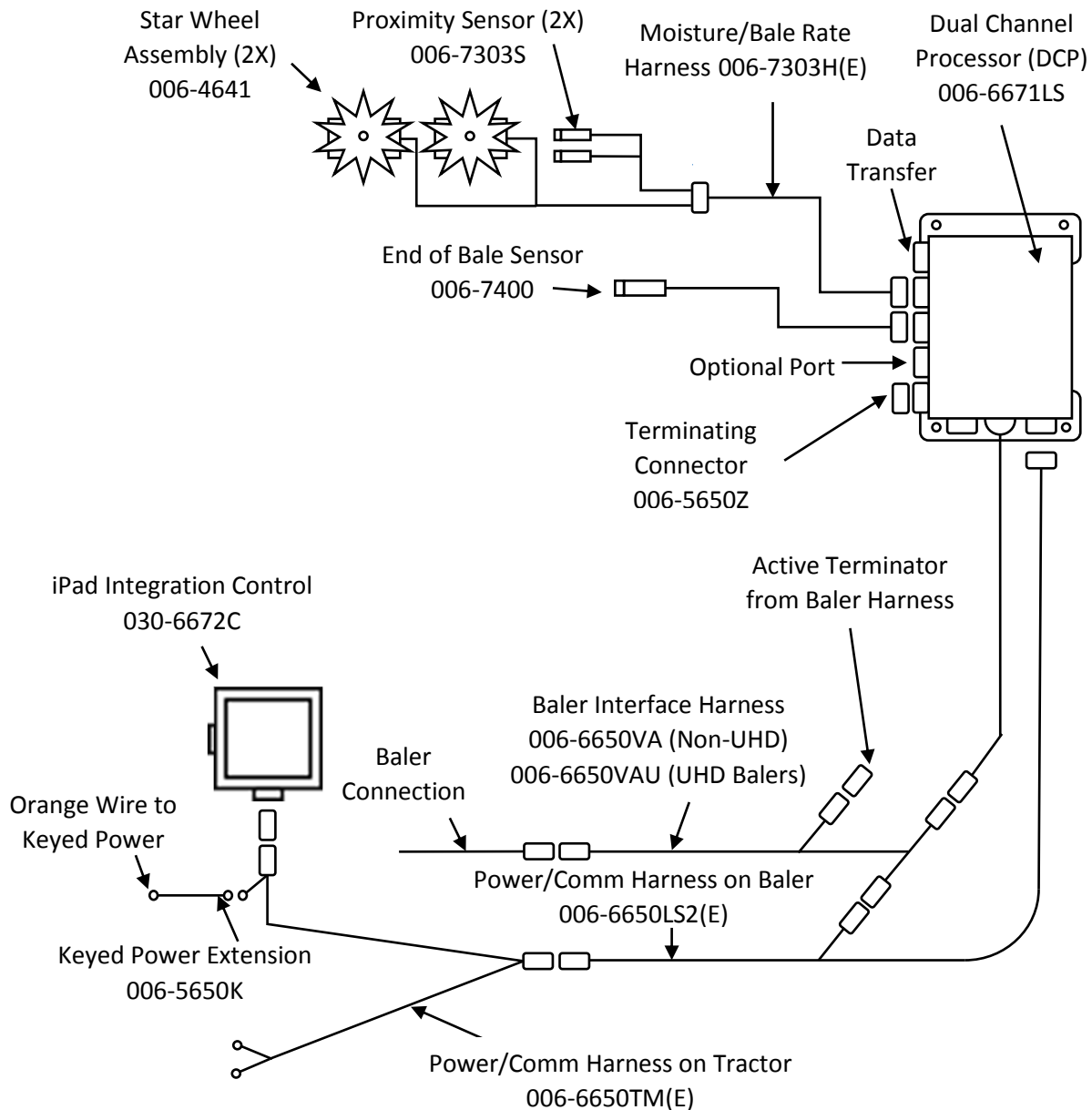

AGCO 2100 Series Balers Pre 2012 need the AGCO Integration Harness (006-6650VAX)

\*Note: (E) indication is used for International Dealers

## Pin Outs

### Power/Comm Harness 006-6650TM(E) at Hitch

Pin 1	Red	+12V Power to TSD
Pin 2	Red	+12V Power to DCP
Pin 3	Orange	Keyed Power
Pin 4	Gray	Shield
Pin 5	Green	HT Can Low
Pin 6	Yellow	HT Can Hi
Pin 7	Orange	Can1 Hi
Pin 8	Black	Ground from TSD
Pin 9	Black	Ground from DCP
Pin 10	Blue	Can1 Low

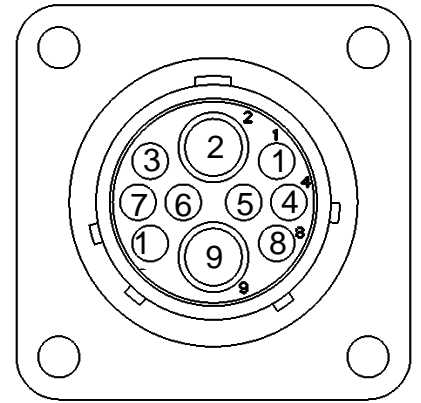

### Power/Comm Harness 006-6650LS2(E) at Hitch

Pin 1	Red	+12V Power to TSD
Pin 2	Red	+12V Power to DCP
Pin 3	Orange	Keyed Power
Pin 4	Gray	Shield
Pin 5	Green	HT Can Low
Pin 6	Yellow	HT Can Hi
Pin 7	Orange	Can1 Hi
Pin 8	Black	Ground from TSD
Pin 9	Black	Ground from DCP
Pin 10	Blue	Can1 Low

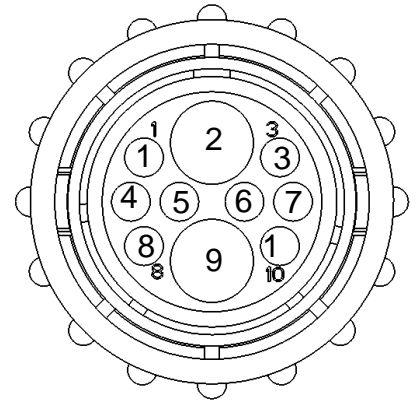

### iPad Integration Control / BLE on Harness 006-6650TM(E)

Pin 1	Red	+12V Power from DCP
Pin 2	Black	Ground from TSD
Pin 3	Yellow	HT Can Low
Pin 4	Gray	Shield
Pin 5	Green	HT Can Hi
Pin 6	Orange	Can1 Hi
Pin 7	Blue	Can1 Low

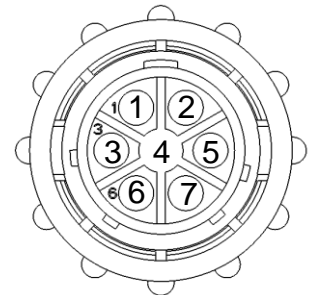

### 006-6650VA to DCP Whip

Pin 1	Red	Can Power
Pin 2	Black	Can Ground
Pin 3	Yellow	HT Can Hi
Pin 4	Gray	Shield
Pin 5	Green	HT Can Low
Pin 6	Orange	Can1 Hi
Pin 7	Blue	Can1 Low

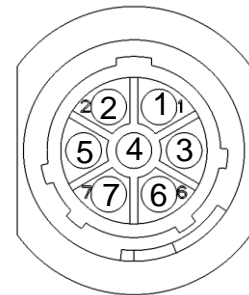

## Pin Outs (continued)

### 006-6650VA to 006-6650LS2(E)

Pin 1	Red	Can Power
Pin 2	Black	Can Ground
Pin 3	Yellow	HT Can Hi
Pin 4	Gray	Shield
Pin 5	Green	HT Can Low
Pin 6	N/A	
Pin 7	N/A	

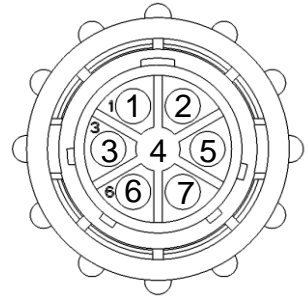

### 006-6650VA & 006-6650VAU Harness to Baler Plug

Pin A	N/A	
Pin B	Red	TBC Power
Pin C	N/A	
Pin D	Gray	TBC Ground
Pin E	Orange	Can1 Hi
Pin F	Blue	Can1 Low

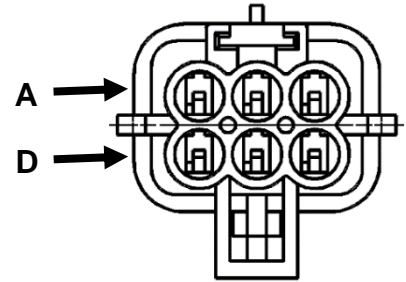

### Main Power Connector on Dual Channel Processor (DCP)

Pin 1	Red	+12V Power from tractor
Pin 2	Black	Ground from tractor
Pin 3	Orange	Keyed power

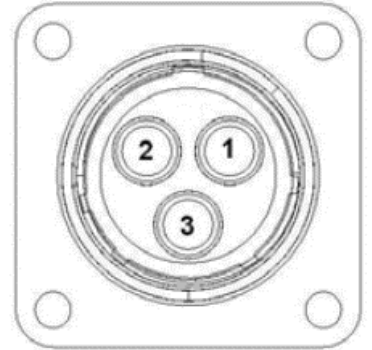

### Star Wheel and Bale Rate Sensor Connector on DCP

Pin 1	Blue	+12V Power
Pin 2	Orange	Ground
Pin 3	Black	Signal for sensor 1
Pin 4	White	Signal for sensor 2
Pin 5	N/A	
Pin 6	N/A	
Pin 7	N/A	
Pin 8	Violet	Star wheel input 1
Pin 9	Brown	Star wheel input 2



### End of Bale Sensor on DCP

Pin 1	Brown	Sensor Power
Pin 2	Blue	Sensor Ground
Pin 3	N/A	
Pin 4	Black	Signal from Sensor

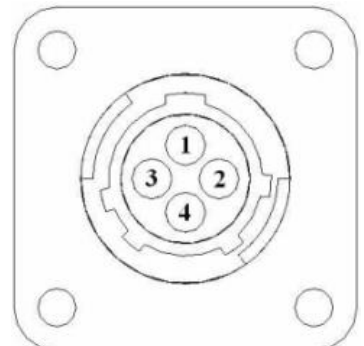

## Common Questions

### 1. How do I turn the system on/off?

To turn the system ON open the Hay App, then select the active system for the baler you are using. Press the Wake Up tab if the system was put into Standby mode when last used. If not in Standby mode, select Automatic or Manual mode to begin.

To turn the system OFF click the Standby tab on the Main Menu screen. To close the app double click the home button on the iPad and swipe the app that you would like closed, toward the top of the screen until it is no longer visible. See SHUTTING DOWN THE HAY APP for more details.

### 2. How to get in the LBS/TON, MC%, and TONS/HR screens?

In the Main Menu press the SETUP MODE key. From this screen you can change your application rates and how much product is applied. See SETTING UP FOR INITIAL USE for a detailed explanation of this process.

### 4. The moisture content displays “LO” or “HI” all the time.

When the moisture content display does not change frequently while baling, there is likely a faulty star wheel connection. Initially check inside the white star wheel block, to see if the electronic swivel is in the star wheel shaft and that the star wheel shaft is not coming out of the block. Also, check all star wheel wires and connectors to see if there is a continuity of grounding problem.

### 5. Should the battery connections be removed before jump starting or charging a battery?

Yes. Anytime the tractor will have voltage going up rapidly the connections should be removed.

### 6. What is the expected battery life of the iPad when baling?

3.5 hours is the expected amount of time the battery when continuously baling. Shut off all other applications, wireless internet, and Wi-Fi signal to reduce the amount of programs iPad is running.

\*It is recommended to use an accessory outlet charger when operating (not included with iPad).

### 7. What is the max distance for connection between the iPad and the Bluetooth Receiver?

The range for the connection will depend on the amount of equipment (tractor, baler, ect.) between the two devices. The max distance will range between 10' – 20'.

### 8. What do the lights on the 030-6672B indicate?

Pre-2020 applicators were equipped Bluetooth receivers (030-6672B) and are now equipped with lights to indicate both power and Hay App connection on the Apple iPad. Red Light – The Bluetooth receiver has power. Green Light – The Bluetooth receiver is connected to the Hay App.

## Troubleshooting

PROBLEM	POSSIBLE CAUSE	SOLUTION
Moisture reading errors (high or low)	1. Wire disconnected or bad connection between star wheels and DCP	1. Reconnect wire.
	2. Low power supply to DCP	2. Check voltage at box. (Min of 12 volts required.) See Diagnostics section of manual.
	3. Dry hay lower than 8% moisture or wet hay over 75%.	3. System reads 8-70% moisture.
	4. Ground contact with one or both star wheels and baler mounted processor.	4. Reconnect.
	5. Short in wire between star wheels and DCP.	5. Replace wire.
	6. Check hay with hand tester to verify.	6. Contact Harvest Tec if conditions persist.
Moisture readings erratic.	1. Test bales with hand tester to verify that DCP has more variation than hand tester.	
	2. Check all wiring connections for corrosion or poor contact.	2. Apply dielectric grease to all connections.
	3. Check power supply at tractor. Voltage should be constant between 12 and 14 volts.	3. Install voltage surge protection on tractors alternator.
Terminal reads under or over power.	1. Verify with multi-meter actual voltage. Voltage range should be between 12-14 volts.	1. Clean connections and make sure applicator is hooked to battery. See Diagnostics section of manual.
Bale rate displays zero.	1. Bale rate sensors are reversed. 2. Short in cable. 3. Damaged sensor. 4. Sensor too far from starwheel.	1. Switch the sensors next to the star wheel. 2. Replace cable. 3. Replace sensor. 4. Adjust gap between prox sensor and star wheel so it is 1/8-1/4" away.
Bluetooth Receiver lights will not illuminate	1. Bluetooth receiver not connected 2. Harness disconnected 3. Low power	1. Check connections and voltage. Minimum 12.5V needed.
	<p>Blinking Lights – System is waiting for the processor to connect, which could take up to 35 seconds.</p> <p><i>Red Light</i> – The Bluetooth receiver has power</p> <p><i>Green Light</i> – When the proper active connection is selected in the Hay App menu, the green light will indicate connection with the iPad.</p>	



## Parts Breakdown

### Star Wheels and Bale Rate Sensors

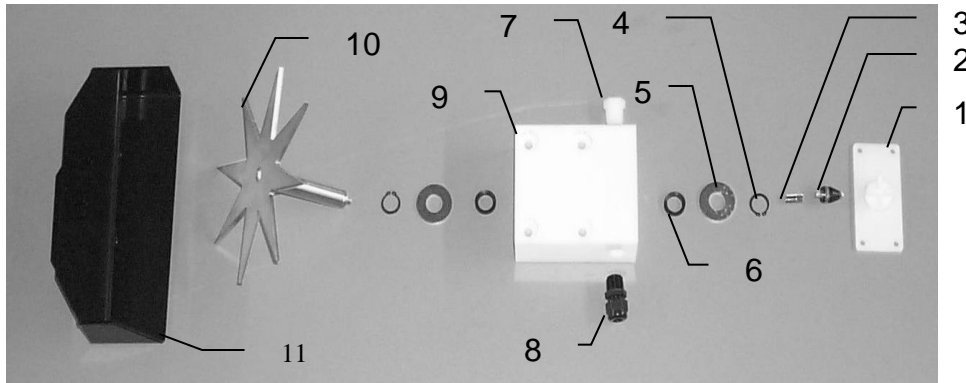

Ref	Description	Part#	Qty	Ref	Description	Part#	Qty
1	Block cover	006-4641B	2	9	Star wheel block	006-4641A	2
2	Electronic swivel	006-4642A	2	10	Star wheel sensor	030-4641C	2
3	Swivel insert	w/ Ref # 10	2	11	Twine guard-left for AGCO	001-4645H	1
4	Snap ring (per side)	006-4641K	2		Twine guard-right for AGCO	001-4644H	1
5	Washer (per side)	w/006-4641K	2		has bale rate sensor		
6	Dust seal (per side)	w/006-4641K	2		holes in it		
7	Plug fitting	003-F38	2	1-10	Star wheel assembly	030-4641	2
8	Wiring grommet	008-0821A	2				

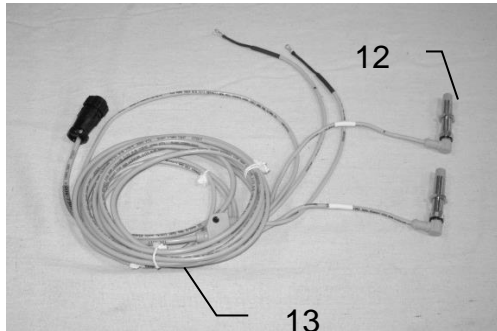

Ref	Description	Part#	Qty
12	Bale rate sensor	006-7303S	2
13	Moisture and bale rate harness	006-7303H(E)	1

\*Note: (E) indication is used for International Dealers

### Star Wheel Moisture Sensors - UHD Balers

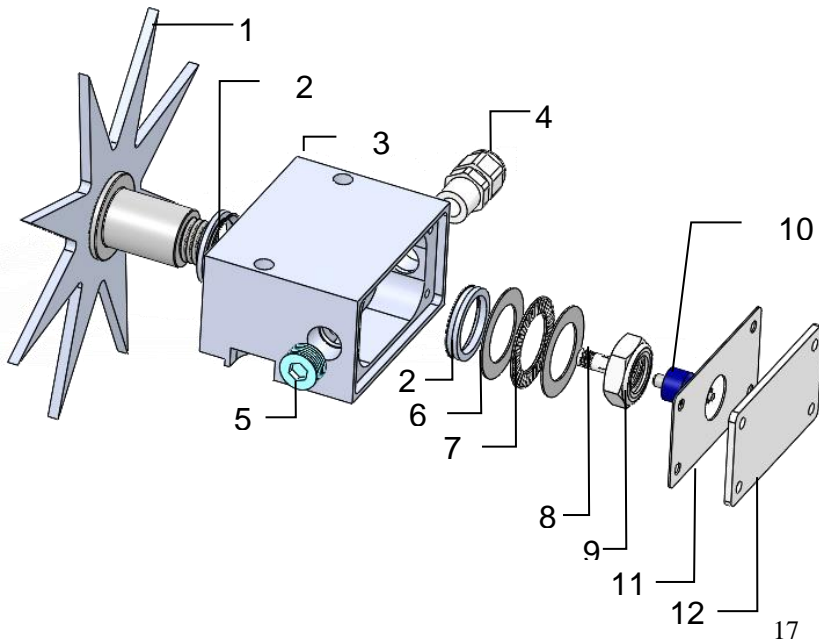

Ref	Description	Part#	Qty
1	Univ Star Wheel	006-4641S	1
2	Dust Seal	006-4641DSL	2
3	Univ Star Block	006-4641Q	1
4	3/8" NPT Cable Grip	008-0821A	1
5	3/8" NPT Plug	003-F38	1
6	Thrust Washer	006-4641TA	2
7	Thrust Bearing	006-4641TB	1
8	Swivel Insert	006-4642B	1
9	3/4" Short Nut	006-4641U	1
10	Rotary Swivel	006-4642A	1
11	Cover Gasket	006-4641RG	1
12	Univ Block Cover	006-4641R	1
	Complete Assembly	030-4641U	2

# Parts Breakdown for 600A & 600UHD Series Control and Harnesses



<u>Ref</u>	<u>Description</u>	<u>Part Number</u>	<u>Qty</u>
1	End Of Bale Sensor	006-7400	1
2	Terminating Connector w green cap	006-5650Z	1
3	End of Bale Sensor Bracket	001-4648	1
4	DCP Shield/Cover	001-5650X	1
5	DCP Main Control LS 600 AUTO	006-6671LS	1
6	DCP Baler Harness 30 FT	006-6650LS2(E)	1
7	DCP Tractor Harness	006-6650TM(E)	1
8	Dust Plugs	006-5651PLUGS	1
9	DCP Baler Interface Harness	006-6650VA	1
10	Key Switch Wire	006-5650K	1
11	iPad Integration Control	030-6672C	1
NP	UHD Integration Harness (UHD Baler)		
NP	USB Cable	006-6672USBC	1
	AGCO 2100 Series Balers Pre 2012 need	006-6650VAX	

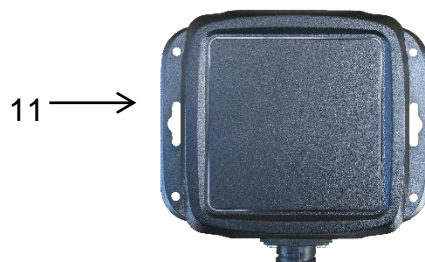

\*Note: (E) indication is used for International Dealers

## **Harvest Tec Inc. Warranty and Liability Agreement**

Harvest Tec, Inc. will repair or replace components that are found to be defective within 12 months from the date of manufacture. Under no circumstances does this warranty cover any components which in the opinion of Harvest Tec, Inc. have been subjected to negligent use, misuse, alteration, accident, or if repairs have been made with parts other than those manufactured and obtainable from Harvest Tec, Inc.

Our obligation under this warranty is limited to repairing or replacing free of charge to the original purchaser any part that in our judgment shows evidence of defective or improper workmanship, provided the part is returned to Harvest Tec, Inc. within 30 days of the failure. If it is determined that a non-Harvest Tec branded hay preservative has been used inside the Harvest Tec applicator system where the failure occurred, then Harvest Tec reserves the right to deny the warranty request at their discretion. Parts must be returned through the selling dealer and distributor, transportation charges prepaid.

This warranty shall not be interpreted to render Harvest Tec, Inc. liable for injury or damages of any kind, direct, consequential, or contingent, to persons or property. Furthermore, this warranty does not extend to loss of crop, losses caused by delays or any expense prospective profits or for any other reason. Harvest Tec, Inc. shall not be liable for any recovery greater in amount than the cost or repair of defects in workmanship.

There are no warranties, either expressed or implied, of merchantability or fitness for particular purpose intended or fitness for any other reason.

This warranty cannot guarantee that existing conditions beyond the control of Harvest Tec, Inc. will not affect our ability to obtain materials or manufacture necessary replacement parts.

Harvest Tec, Inc. reserves the right to make design changes, improve design, or change specifications, at any time without any contingent obligation to purchasers of machines and parts previously sold.

Revised 4/17

**HARVEST TEC, INC.**  
**P.O. BOX 63**  
**2821 HARVEY STREET**  
**HUDSON, WI 54016**  
PHONE: 715-386-9100  
1-800-635-7468  
FAX: 715-381-1792  
Email: [info@harvesttec.com](mailto:info@harvesttec.com)