

Installation Manual

Model 600BB

***Moisture Sensor Kit for Large Square Balers
For New Holland BigBaler and Case IH LB 4***

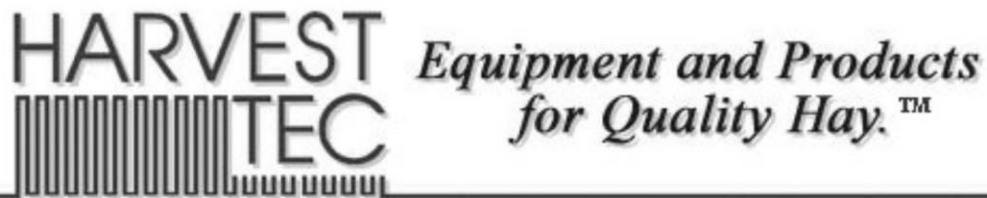

P.O. Box 63 • 2821 Harvey Street • Hudson, WI 54016
800-635-7468 • www.harvesttec.com

DECLARATION OF INCORPORATION



MANUFACTURER:

Harvest Tec Inc.
2821 Harvey St.
P.O. Box 63
Hudson, WI 54016, U.S.A.

REPRESENTATIVE ESTABLISHED IN COMMUNITY: Profitable Farming Company
Middle Barlington, Roborough
Winkleigh, Devon, EX19 8AG
ENGLAND

The person above certifies and declares that:

VIRTUAL MACHINE: Equipment mounted on a farm press and for the application of inoculants onto forage crops.

MODEL: 600BB-INST-17-Imp&Metric

BRAND: Harvest Tec

SERIAL NUMBER:

This application preservatives for hay Harvest Tec system meets the Directive 2006/42/EC of the European Parliament and the Council of 17 May 2006 and other applicable European Directives including Directive 2004/108/EC on the Electromagnetic compatibility.

The application of preservatives for hay Harvest Tec system will be turned on after being installed on a farm press has been declared in conformity with the Machinery Directive.

Person in the community authorized to provide information on the partly completed machinery and making this statement:

Richard Snell, President, Profitable Farming Company
Signed on May 21, 2011: Middle Barlington, Roborough
Winkleigh, Devon, EX19 8AG
ENGLAND

Harvest Tec Model 600BB Installation Table of Contents

	<u>PAGE</u>
Introduction	4
System Requirements	4
Tools Needed	4
Installation of the 600BB Moisture Sensor Kit	5-8
Mounting the 600BB Dual Channel Processor (DCP)	5
Installation and Routing Wire Harnesses and Baler Interface Harness	6
Installation of iPad Integration Control	7
iPad Integration control Light Signals	7
Bluetooth Receiver Lights	7
Installation of the Star Wheels	8
Connecting the Star Wheels to the DCP	8
Installation of Star Wheel and Bale Rate Harness	9
Installation of End of Bale Sensor	9
Wiring Diagram	10
Pin Outs	11-12
Troubleshooting	13
Parts Breakdown	14-17
Controls and Harnesses	14
Star Wheel Sensors	15
Optional iPad Mini Mounting Kit	16
Optional iPad Display Kit	17
Notes	18
Warranty	19

Introduction

Thank you for purchasing this 600BB Moisture Sensor Kit. The 600BB Moisture Sensor Kit is designed to operator through the baler's ISOBUS system and/or an Apple iPad (not included) using the Hay App. The 600BB Moisture Sensor offers these advantages:

1. Operation coordinated with baler operation
2. Less cab clutter providing better visibility
3. Ease of use with all information on one screen
4. Records kept together
5. The system is ready for future updates

This manual will take you through the steps of installing the moisture sensor. Please read this manual carefully to learn how to install the equipment correctly. Failure to do this can result in personal injury or equipment malfunction. If you are unsure about installing the system after consulting this manual, contact your local authorized dealership for additional assistance or look for the contact information on the back cover of this manual. If you are in need of parts for the system please view the Parts Breakdowns in the back of this manual and contact your local authorized dealer to order the parts.

Right and Left sides are determined by facing in the direction of forward travel.

System Requirements



**The Baler Control Module (BCM)
must have Version 4.2.0.0 or higher.**

***Made for iPad® (3rd through Pro 2nd generation), running the current iOS operating system
or one version previous required for iPad option**

*iPad is a trademark of Apple Inc., registered in the U.S. and other countries.

****600 Series Applicators with serial number before DCP27000 will require the DCP to be sent to Harvest Tec for a required update in order to use the iPad Integration Module (030-6672C).**

*Hay App version must be **at least 2.5.18 (or higher)** to operate with the iPad Integration Module

*If choosing to operate the unit through the ISOBUS monitor, part number 006-6670A
will need to be ordered through your local equipment dealer.*

In order for the CNH Baler to receive the ThirtyPlus or CropSaver System messages regarding Status, Moisture and preservative, and display this information on the Baler Work Screen, the software in the Baler Control Module (BCM) needs to be updated to version 4.2.0.0 or higher. Dealers can log an ASIST incident and request the BCM software from CNH Technical Support Services if they need the software prior to those release dates.

Tools Needed

Standard Wrench set
Electric drill and bits
Side cutter

Standard Socket Set
Hammer
Center punch

Installation of the 600BB Dual Channel Processor (DCP)

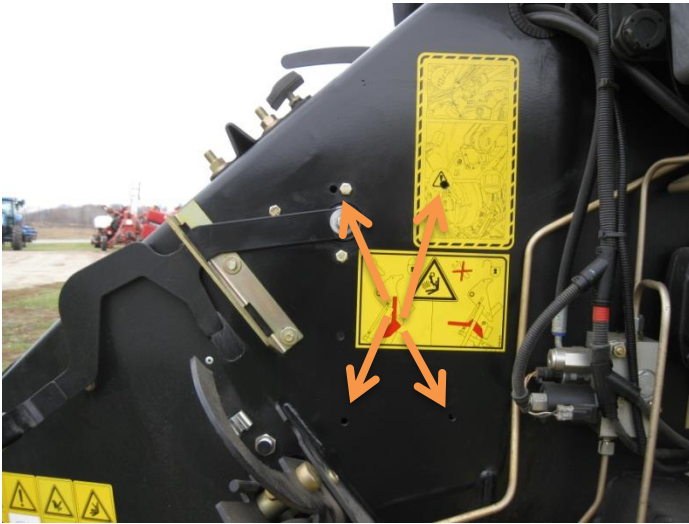

Figure 1

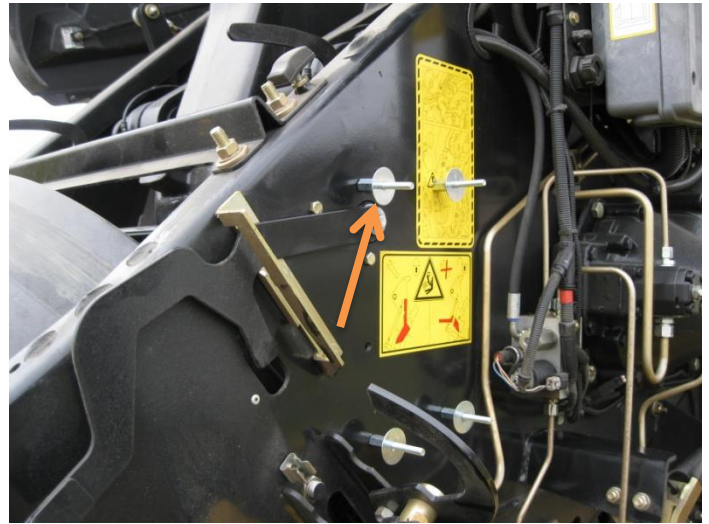

Figure 2

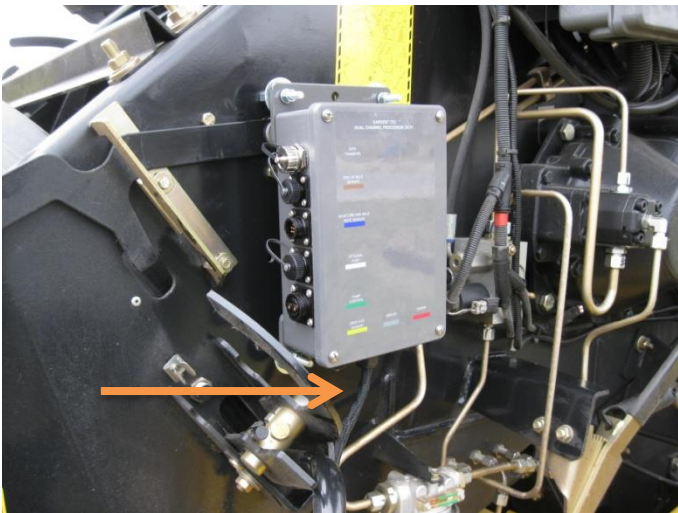

Figure 3

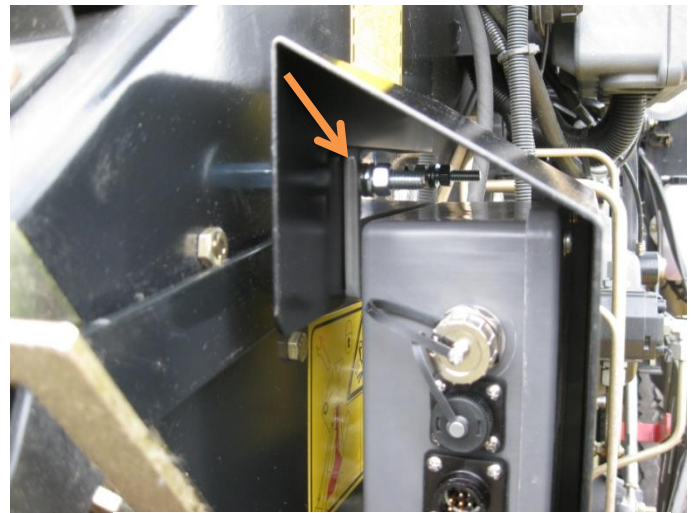

Figure 4

1. Locate the Dual Channel Processor (DCP) 006-6671LS.
2. Lock the baler flywheel brake and lift open the front hood.
3. Locate the four holes by the fly wheel brake (Figure 1).
4. Use four 5/16" x 3" hex bolts with four flat washers (positioning bolt heads on the inside of the baler frame) and secure to the baler with four 1 1/8" threaded standoffs that will be on the outside of the baler frame, Position four fender washers between the DCP and standoffs (Figure 2).
5. Mount the DCP with the display cable pointed down to the baler (Figure 3).
6. Attach lock washers and hex nuts to mount the DCP to the baler. Do not tighten down yet.
7. Before tightening hardware install the DCP shield (001-5650X) over the top two 5/16" bolts between the fender washers and the mounting plate of the DCP. Tighten all hex nuts (Figure 4).

Installation and Routing Wire Harnesses and Baler Interface Harness



Route harnesses along inside of the baler (Left). Keep harnesses away from moving parts and hydraulic hoses. Secure with existing cable clamps or use cable ties. When all connections are made to the DCP secure wires as shown above to allow for water to be shed away from the DCP.



Locate and remove the Active Terminator (below left) of baler. Attach Baler Interface Harness (006-6650VA) to that location. Reconnect Active Terminator (below) to open port of that same harness (006-6650VA)



Installation of iPad Integration Control

Locate a safe location in the cab of the tractor to place the iPad Integration Control (030-6672C). Recommended location is securely fastened out of the operators way in a location that is close enough to reach with the iPad cord.

Connect the Power / Communication harness (006-6650TM(E)) to the bottom of the receiver.

To operate the applicator, plug the iPad cord into the communication port indicated by:

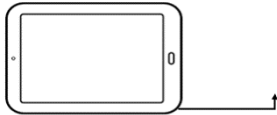

iPad Integration Control Light Signals

Green Slow Blink – Power supplied to the applicator system and the unit is going through its startup process. This will take approximately 25-35 seconds.

Green Double Blink – Indicating the iPad module recognizes the iPad but the app is not open or connected.

Green Solid Light – Module is connected to the app and is ready to operate.

*Recommended to use the USB cable included with the applicator kit (006-6672USBC)

Bluetooth Receiver Lights

Pre-2020 applicators equipped with Bluetooth receivers (030-6672B) are now equipped with lights to indicate both power and Hay App connection on the Apple iPad. Clean light regularly

Blinking Lights – System is waiting for the processor to connect, which could take up to 35 seconds.

Red Light – The Bluetooth receiver has power

Green Light – The Bluetooth receiver is connected to the Hay App.



****600 Series Applicators with serial number before DCP27000 will require the DCP to be sent to Harvest Tec for a required update in order to use the iPad Integration Module (030-6672C).**

Hay App version must be **at least 2.5.18 (or higher)** to operate with the iPad Integration Module

*Made for Apple iPad badge

Use of the Made for Apple iPad badge means that an accessory has been designed to connect specifically to the Apple product(s) identified in the badge and has been certified by the developer to meet Apple performance standards. Apple is not responsible for the operation of this device or its compliance with safety and regulatory standards.

Please note that the use of this accessory with an Apple product may affect wireless performance.

Installation of Star Wheel Moisture Sensors

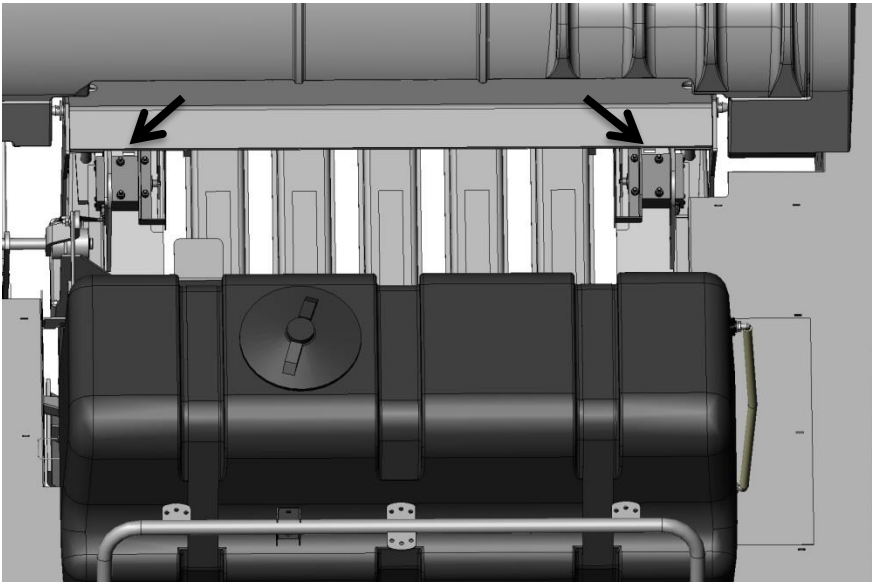

Figure 5

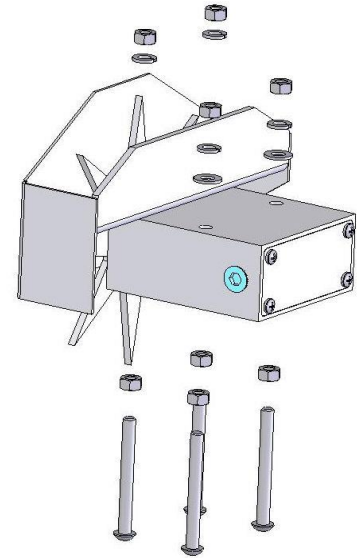

Figure 6

1. Locate the two star wheel moisture sensors (030-4641) and twine diverters (001-4644 & 001-4645).
2. Directly behind the knotters, locate the four predrilled holes per side shown at the arrows. This location is also beneath the lift points on top of the baler (Figure 5).
3. Install the eight (four per side) 5/16" X 3" Allen head cap screws. Make sure the Allen heads are in the bale chamber. Secure using 5/16" hex nuts (Figure 6).
4. Install the star wheels below the lift points on the baler.
5. Install the twine diverters over the star wheel sensor. The twine diverter with two extra holes will be installed on the right star wheel when looking from the rear of the baler toward the tractor.
6. Secure the star wheels and twine diverters with four M8 hex nuts, lock washers, and two flat washers (Figure 6).

Connecting Star Wheels to the DCP



Locate the moisture harness (006-7303HL). Remove the four pan head screws on each star wheel and loosen the grommet. Insert the eye loop of the wire into the star wheel block and install on the end of the swivel. Leave a loop in the wire to allow the star wheel cover space to be reinstalled.

Tighten the swivel nut, followed by the grommet, and finally install and tighten the four screws. The picture to the left shows the star wheel block open with the wire looped and attached to the swivel. Once both wheels are complete route the harness towards the DCP. Secure loose wires with cable ties.

Installation of Star Wheel and Bale Rate Harness

First, remove the cover from the star wheel block and use a 1/4" nut driver to remove the nut from the electronic swivel. Next, run the star wheel sensor wire through the black grommet and place the eye terminal on the star wheel sensor. Tighten the eye loop with the nut on the sensor and put the star wheel cover back on the base. Next, tighten the grommet to form a tight seal around the wire. The bale rate sensors will be factory installed on the right side twine guard in the correct position. The sensor with the longer sensor wire should say "FRONT" which indicates it should be placed in the front sensor hole. The sensor wire with the shorter wire should say "BACK." The tip of the sensor should be placed no more than 1/4" (7mm) away from the star wheel teeth and no less than 1/8" (3mm) from the star wheel teeth. Each sensor will have an LED light located on the sensor by the diverter. Once the unit is powered up spin the wheel and make sure that both led lights turn on and off. If they don't turn on and off, adjustments may need to be made.

Once the star wheel connection is complete, run the harness along the left side baler frame to the Dual Channel Processor (DCP). The Dual Channel Processor is located next to the flywheel brake.

Installation of End of Bale Sensor

The end of bale sensor determines the position of the needles on the baler. When the needles cycle the sensor communicates this information to the Dual Channel Processor. This information is used for job records and will be used by the optional Bale Identification system.

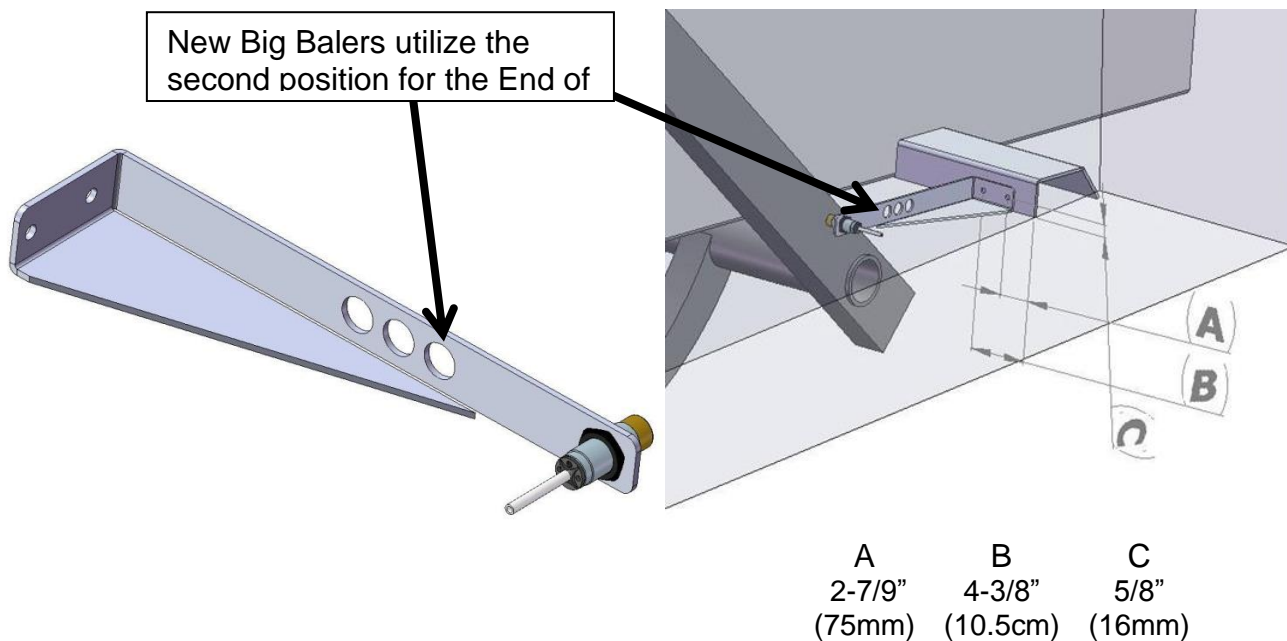

Mount the end of bale sensor bracket (001-4648) as shown (above) on the ladder side of the baler (and same side as the main controller). Mark and drill two 3/8" (10mm) holes and attach the bracket using two 5/16" x 1" self-tapping screws, and 5/16" flange nuts. Keep the sensor 1/4" (7mm) from the needle and tighten both nuts.

New BB Balers have been installing the End of Bale Sensor in the second position and trimming off the excess steel. Run the sensor cable (006-7400) and extension (006-7400BBEXT) up to the Dual Channel Processor (DCP) down the ladder side of the baler and secure it properly out of the way of any moving parts and hydraulics.

Wiring Diagram

- A. The Baler Power/Communication Harness (006-6650LS(E)) will attach to the open port of the Tractor Harness (006-6650TM(E)) and run back to the Dual Channel Processor (006-6671LS(E)).
- B. Connect the large plug of the Baler Power/Communication Harness (006-6650LS) to the bottom (shorter side) of the DCP. Attach the Baler Interface Harness (006-6650VA) in between the short whip cable hardwired to the DCP and the Power/Communication Harness (006-6650LS(E)).
- C. Make sure Active Terminator removed from the top of the baler processor is attached to the Baler Interface Harness (006-6650VA).
- D. Attach moisture and bale rate harness (006-7303HL(E)) and also end of bale harness (006-7400BBEXT) to the DCP (006-6671LS).
- E. Connect Keyed Power Extension harness (006-5650K) to a keyed power source.
- F. Connect the iPad Integration Control (030-6672C) to the Communication Harness (006-6650TM).
- G. Note: The Optional Port and the Data Transfer Port are not used in this application.

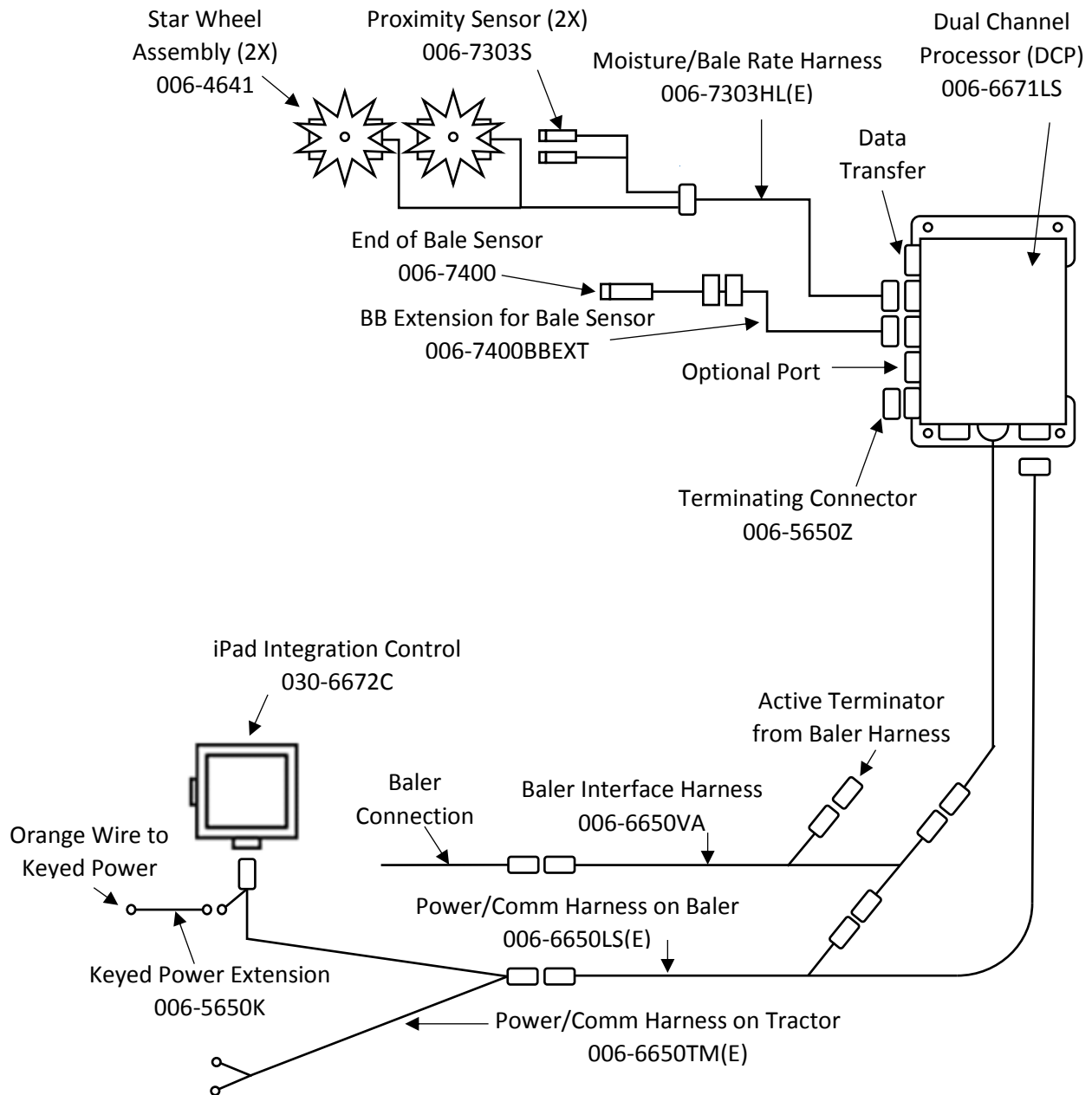

*Note: (E) indication is used for International

Pin Outs

Power/Comm Harness 006-6650TM(E) at Hitch

Pin 1	Red	+12V Power to TSD
Pin 2	Red	+12V Power to DCP
Pin 3	Orange	Keyed Power
Pin 4	Gray	Shield
Pin 5	Green	HT Can Low
Pin 6	Yellow	HT Can Hi
Pin 7	Orange	Can1 Hi
Pin 8	Black	Ground from TSD
Pin 9	Black	Ground from DCP
Pin 10	Blue	Can1 Low



Power/Comm Harness 006-6650LS(E) at Hitch

Pin 1	Red	+12V Power to TSD
Pin 2	Red	+12V Power to DCP
Pin 3	Orange	Keyed Power
Pin 4	Gray	Shield
Pin 5	Green	HT Can Low
Pin 6	Yellow	HT Can Hi
Pin 7	Orange	Can1 Hi
Pin 8	Black	Ground from TSD
Pin 9	Black	Ground from DCP
Pin 10	Blue	Can1 Low



iPad Integration Control / BLE on Harness 006-6650TM(E)

Pin 1	Red	+12V Power from DCP
Pin 2	Black	Ground from TSD
Pin 3	Yellow	HT Can Low
Pin 4	Gray	Shield
Pin 5	Green	HT Can Hi
Pin 6	Orange	Can1 Hi
Pin 7	Blue	Can1 Low

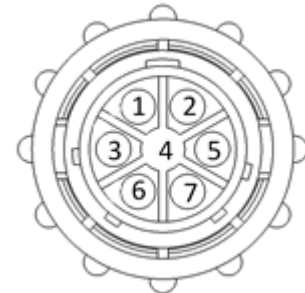

006-6650VA to DCP Whip

Pin 1	Red	Can Power
Pin 2	Black	Can Ground
Pin 3	Yellow	HT Can Hi
Pin 4	Gray	Shield
Pin 5	Green	HT Can Low
Pin 6	Orange	Can1 Hi
Pin 7	Blue	Can1 Low



Pin Outs (continued)

006-6650VA to 006-6650LS(E)

Pin 1	Red	Can Power
Pin 2	Black	Can Ground
Pin 3	Yellow	HT Can Hi
Pin 4	Gray	Shield
Pin 5	Green	HT Can Low
Pin 6	N/A	
Pin 7	N/A	



006-6650VA Harness to Baler Plug

Pin A	N/A	
Pin B	Red	TBC Power
Pin C	N/A	
Pin D	Gray	TBC Ground
Pin E	Orange	Can1 Hi
Pin F	Blue	Can1 Low

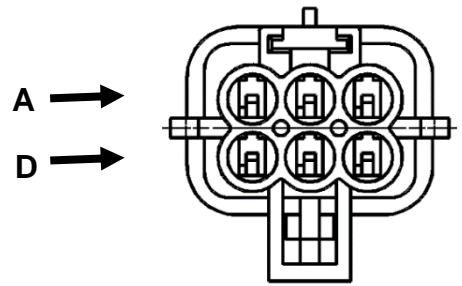

Main Power Connector on DCP

Pin 1	Red	+12V Power from tractor
Pin 2	Black	Ground from tractor
Pin 3	Orange	Keyed power

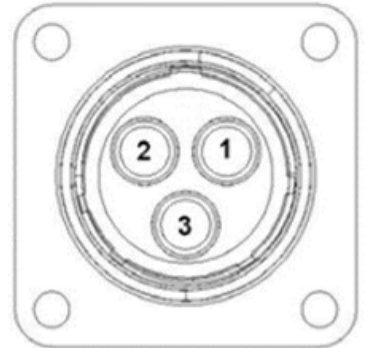

Star Wheel and Bale Rate Sensor Connector on DCP

Pin 1	Blue	+12V Power
Pin 2	Orange	Ground
Pin 3	Black	Signal for sensor 1
Pin 4	White	Signal for sensor 2
Pin 5	N/A	
Pin 6	N/A	
Pin 7	N/A	
Pin 8	Violet	Star wheel input 1
Pin 9	Brown	Star wheel input 2



End of Bale Sensor on DCP

Pin 1	Brown	Sensor Power
Pin 2	Blue	Sensor Ground
Pin 3	N/A	
Pin 4	Black	Signal from Sensor

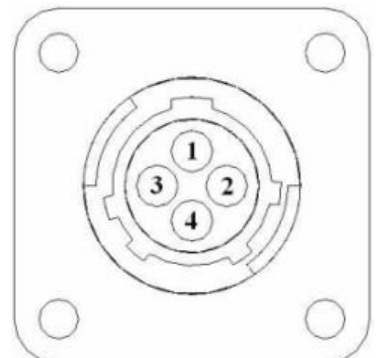

Troubleshooting

PROBLEM	POSSIBLE CAUSE	SOLUTION
Moisture reading errors (high or low)	1. Wire disconnected or bad connection between star wheels and DCP	1. Reconnect wire.
	2. Low power supply to DCP	2. Check voltage at box. (Min of 12 volts required.) See Diagnostics section of manual.
	3. Dry hay lower than 8% moisture or wet hay over 75%.	3. System reads 8-70% moisture.
	4. Ground contact with one or both star wheels and baler mounted processor.	4. Reconnect.
	5. Short in wire between star wheels and DCP.	5. Replace wire.
	6. Check hay with hand tester to verify.	6. Contact Harvest Tec if conditions persist.
Moisture readings erratic.	1. Test bales with hand tester to verify that DCP has more variation than hand tester.	
	2. Check all wiring connections for corrosion or poor contact.	2. Apply dielectric grease to all connections.
	3. Check power supply at tractor. Voltage should be constant between 12 and 14 volts.	3. Install voltage surge protection on tractors alternator.
Terminal reads under or over power.	1. Verify with multi-meter actual voltage. Voltage range should be between 12-14 volts.	1. Clean connections and make sure applicator is hooked to battery. See Diagnostics section of manual.
Bale rate displays zero.	1. Bale rate sensors are reversed. 2. Short in cable. 3. Damaged sensor. 4. Sensor too far from starwheel.	1. Switch the sensors next to the star wheel. 2. Replace cable. 3. Replace sensor. 4. Adjust gap between prox sensor and star wheel so it is 1/8-1/4" away.
Bluetooth Receiver lights will not illuminate	1. Bluetooth receiver not connected 2. Harness disconnected 3. Low power	1. Check connections and voltage. Minimum 12.5V needed.
	<p><i>Blinking Lights</i> – System is waiting for the processor to connect, which could take up to 35 seconds.</p> <p><i>Red Light</i> – The Bluetooth receiver has power</p> <p><i>Green Light</i> – When the proper active connection is selected in the Hay App menu, the green light will indicate connection with the iPad.</p>	

Parts Breakdown

600BB Series Controls and Harnesses Dual Channel Processor (DCP)

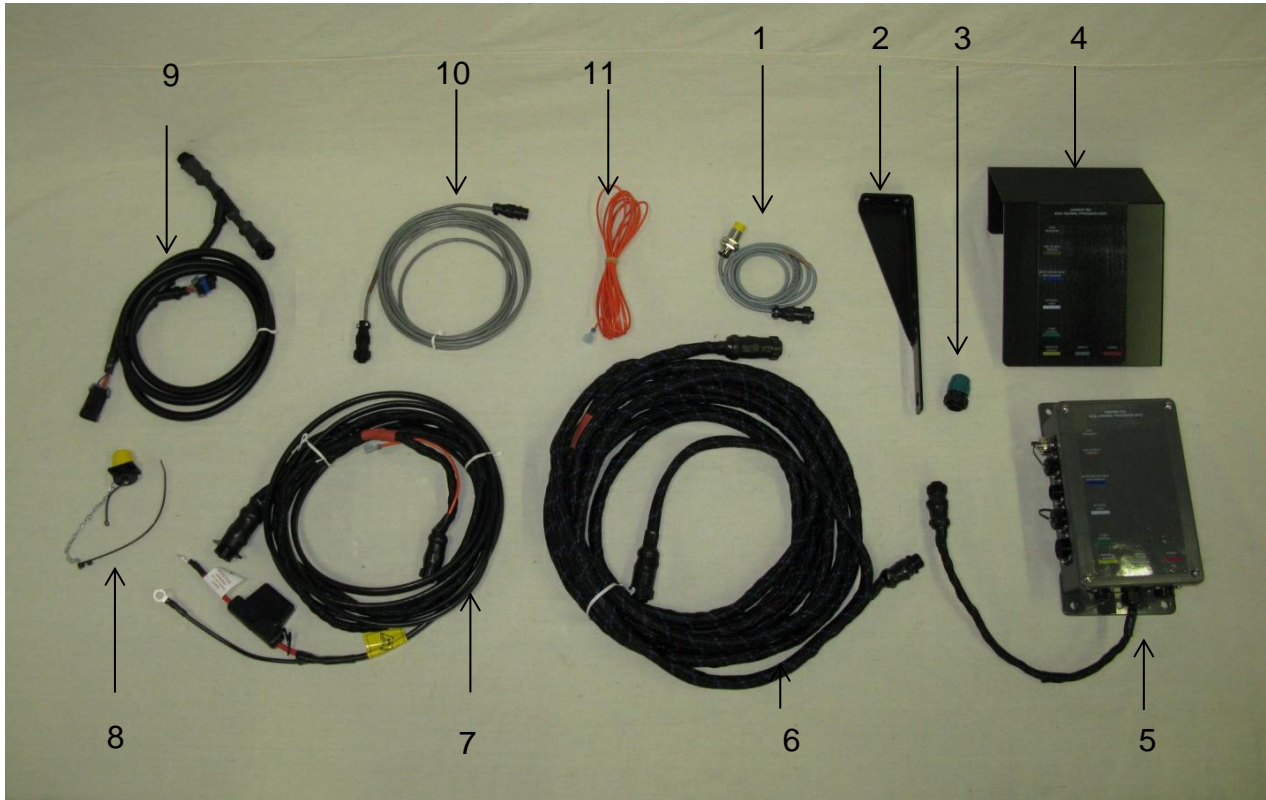

<u>Ref</u>	<u>Description</u>	<u>Part Number</u>	<u>Qty</u>
1	End of Bale Sensor 600 Series	006-7400	1
2	End of Bale Sensor Bracket	001-4648	1
3	Terminating Connector 600 Series w/green cap	006-5650Z	1
4	DCP Shield/Cover	001-5650X	1
5	DCP Main Control LS 600 AUTO	006-6671LS	1
6	DCP Baler Harness 15 FT	006-6650LS(E)	1
7	DCP Tractor Harness	006-6650TM(E)	1
8	Dust Plugs	006-5651PLUGS	1
9	DCP Baler ISO/VT Harness	006-6650VA	1
10	EOB Extension for CNH BB Series	006-7400BBEXT	1
11	Key Switch Wire	006-5650K	1
12	iPad Integration Control	030-6672C	1
NP	USB Cord	006-6672USBC	1

12 →



*Note: (E) indication is used for International

Star Wheel Moisture Sensor and Bale Rate Sensors

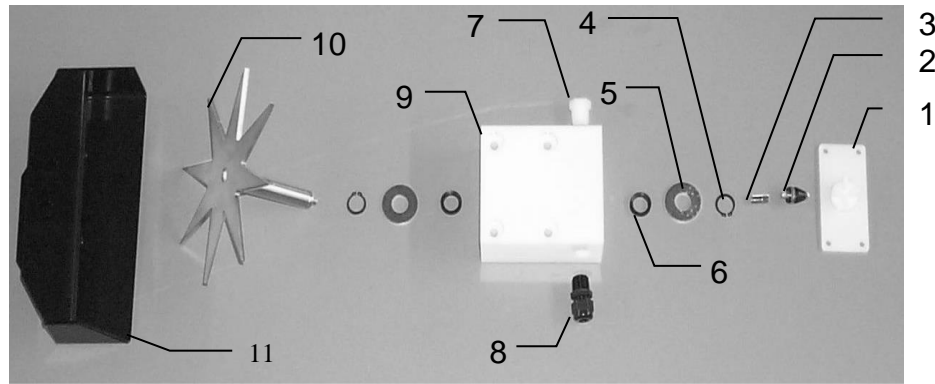

<u>Ref</u>	<u>Description</u>	<u>Part Number</u>	<u>Qty</u>	<u>Ref</u>	<u>Description</u>	<u>Part Number</u>	<u>Qty</u>
1.	Block cover	006-4641B	2	9.	Star wheel block	006-4641A	2
2.	Electronic swivel	006-4642A	2	10.	Star wheel sensor	030-4641C	2
3.	Swivel insert	w/ Ref # 10	2	11.	Twine guard-left	001-4645	1
4.	Snap ring (per side)	006-4641K	2		Twine guard-right (prox)	001-4644	1
5.	Washer (per side)	w/006-4641K	2		And with bale rate sensor		
6.	Dust seal (per side)	w/006-4641K	2		holes in it		
7.	Plug fitting	003-F38	2	1-10	Star wheel assembly	030-4641	2
8.	Wiring grommet	008-0821A	2				

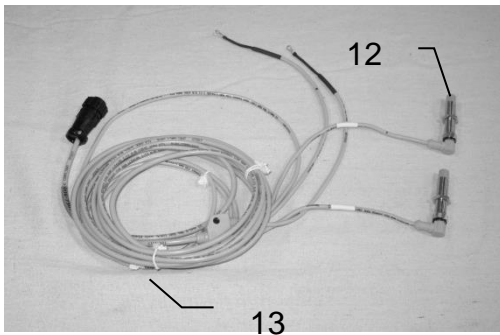

<u>Ref</u>	<u>Description</u>	<u>Part Number</u>	<u>Qty</u>
12	Bale rate sensor	006-7303S	2
13	Moisture and bale rate harness	006-7303HL(E)	1

*Note: (E) indication is used for International

Optional iPad Mini Mounting Kit (030-2014MK)

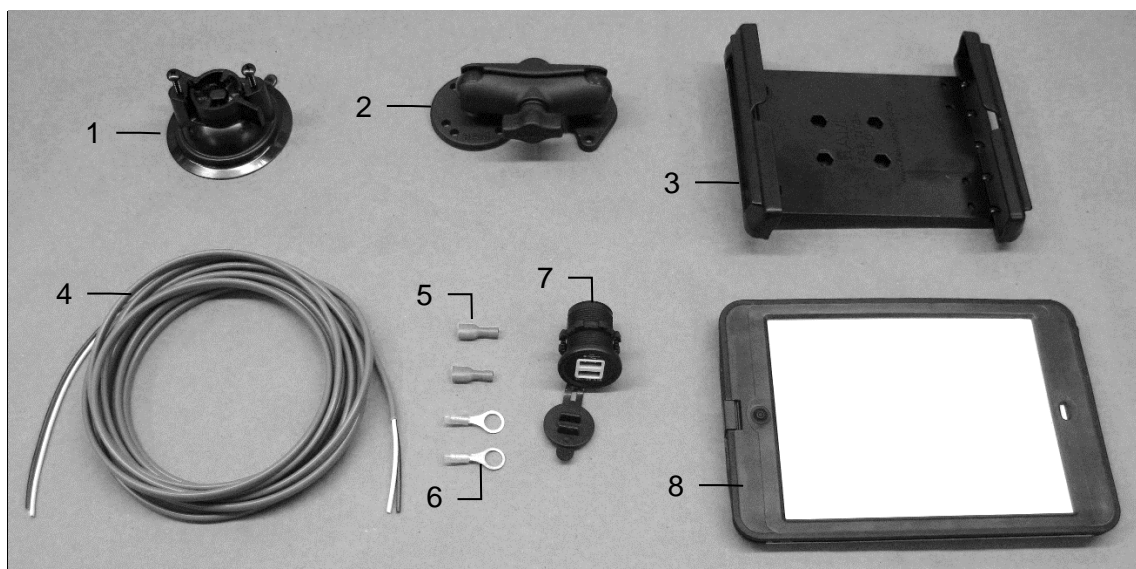

<u>Ref</u>	<u>Description</u>	<u>Part #</u>	<u>Qty</u>
1	Suction cup mount	001-2012SCM	1
2	Ram mount	001-2012H	1
3	iPad Mini® spring load cradle (Mini 4)	001-2012SLC	1
4	16 gauge power wire	006-4723P	1
5	Female spade connector	Hardware	2
6	Eye loop connector	Hardware	2
7	iPad Mini Charger 12V	001-2012P	1
8	iPad Mini 4 case	001-2012C4	1
NP	4 amp fuse	Hardware	1
Mounting Kit Assembly		030-2014MK (Includes All Parts)	

Installation Instructions

1. Identify 12V power source for wires to connect.
 - a. Eye loops included if wiring directly to the battery is desired.
 - b. Test for key power source if preferred to have power to the USB shut off with the key.
2. Once power source is identified, cut wires to desired length.
3. Crimp the two supplied quick connectors onto each the white and black wire.
4. Remove the round locking plastic nut from USB plug before connecting the wires. Black (+) White (-).
5. The wires will then be hooked to the designated terminals on the bottom of the USB plug
6. Drill a 1 1/8" hole in the preferred mounting location. Be sure to clean any sharp edges after drilling.
7. Feed the wires through the mounting hole.
8. If using the round plastic nut to secure plug in place, slide the nut back over the wiring before connecting the wires to powered source.
9. Connect the wires to the identified power source if easier to do so before tightening the plug into place.
10. Tighten plug using either the round plastic nut or mounting plate and two screws, both options supplied.
11. Once connected, hook a USB charging cord into the plug and connect a mobile device/tablet to ensure the plug is operating as you wish (key power working properly if necessary).

NOTE: This plug is not designed to charge two iPads. System damage could occur if this is attempted. System will charge a mobile phone and iPad simultaneously without problem.

*iPad mini is a trademark of Apple Inc., registered in the U.S. and other countries.

Optional iPad Display Kit (030-4670DK)

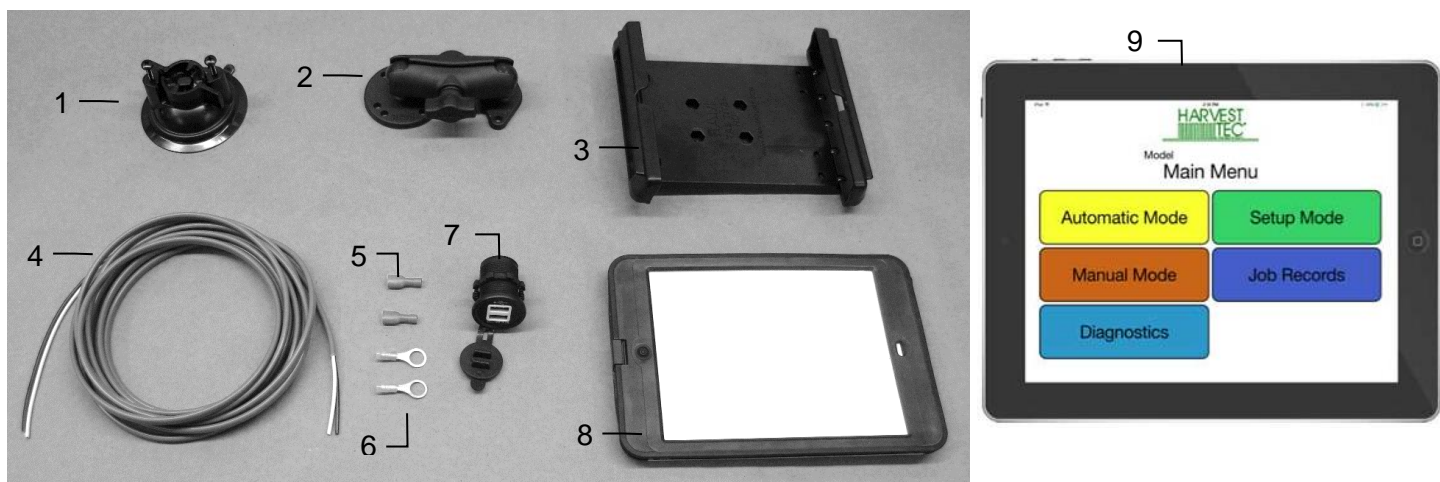

Ref	Description	Part #	Qty	Ref	Description	Part #	Qty
1	Suction cup mount	001-2012SCM	1	7	iPad Mini Charger 12V	001-2012P	1
2	Ram mount	001-2012H	1	8	iPad Mini 4 case	001-2012C4	1
3	iPad Mini® spring load cradle (Mini 4)	001-2012SLC	1	9	iPad Mini 4	006-4670IP	1
4	16 gauge power wire	006-4723P	1	NP	4 amp fuse	Hardware	1
5	Female spade connector	Hardware	2		Mounting Kit Assembly	030-4670DK	
6	Eye loop connector	Hardware	2			(Includes All Parts)	

Installation Instructions

1. Identify 12V power source for wires to connect.
 - a. Eye loops included if wiring directly to the battery is desired.
 - b. Test for key power source if preferred to have power to the USB shut off with the key.
2. Once power source is identified, cut wires to desired length.
3. Crimp the two supplied quick connectors onto the white and black wire.
4. Remove the round locking plastic nut from USB plug before connecting the wires. Black (+) White (-).
5. The wires will then be hooked to the designated terminals on the bottom of the USB plug
6. Drill a 1 1/8" hole in the preferred mounting location. Be sure to clean any sharp edges after drilling.
7. Feed the wires through the mounting hole.
8. If using the round plastic nut to secure plug in place, slide the nut back over the wiring before connecting the wires to powered source.
9. Connect the wires to the identified power source if easier to do so before tightening the plug into place.
10. Tighten plug using either the round plastic nut or mounting plate and two screws, both options supplied.
11. Once connected, hook a USB charging cord into the plug and connect a mobile device/tablet to ensure the plug is operating as you wish (key power working properly if necessary).

NOTE: This plug is not designed to charge two iPads. System damage could occur if this is attempted. System will charge a mobile phone and iPad simultaneously without problem.

*iPad mini is a trademark of Apple Inc., registered in the U.S. and other countries.

Notes

Harvest Tec Inc. Warranty and Liability Agreement

Harvest Tec, Inc. will repair or replace components that are found to be defective within 12 months from the date of manufacture. Under no circumstances does this warranty cover any components which in the opinion of Harvest Tec, Inc. have been subjected to negligent use, misuse, alteration, accident, or if repairs have been made with parts other than those manufactured and obtainable from Harvest Tec, Inc.

Our obligation under this warranty is limited to repairing or replacing free of charge to the original purchaser any part that in our judgment shows evidence of defective or improper workmanship, provided the part is returned to Harvest Tec, Inc. within 30 days of the failure. If it is determined that a non-Harvest Tec branded hay preservative has been used inside the Harvest Tec applicator system where the failure occurred, then Harvest Tec reserves the right to deny the warranty request at their discretion. Parts must be returned through the selling dealer and distributor, transportation charges prepaid.

This warranty shall not be interpreted to render Harvest Tec, Inc. liable for injury or damages of any kind, direct, consequential, or contingent, to persons or property. Furthermore, this warranty does not extend to loss of crop, losses caused by delays or any expense prospective profits or for any other reason. Harvest Tec, Inc. shall not be liable for any recovery greater in amount than the cost or repair of defects in workmanship.

There are no warranties, either expressed or implied, of merchantability or fitness for particular purpose intended or fitness for any other reason.

This warranty cannot guarantee that existing conditions beyond the control of Harvest Tec, Inc. will not affect our ability to obtain materials or manufacture necessary replacement parts.

Harvest Tec, Inc. reserves the right to make design changes, improve design, or change specifications, at any time without any contingent obligation to purchasers of machines and parts previously sold.

Revised 4/17

HARVEST TEC, INC.
P.O. BOX 63
2821 HARVEY STREET
HUDSON, WI 54016
PHONE: 715-386-9100
1-800-635-7468
FAX: 715-381-1792
Email: info@harvesttec.com