

# Installation Manual

## ***Model 600RB*** ***Moisture Sensor Kit for Round Balers***



---

P.O. Box 63 • 2821 Harvey Street • Hudson, WI 54016  
800-635-7468 • [www.harvesttec.com](http://www.harvesttec.com)

**DECLARATION OF INCORPORATION**



**MANUFACTURER:**

Harvest Tec Inc.  
2821 Harvey St.  
P.O. Box 63  
Hudson, WI 54016, U.S.A.

**REPRESENTATIVE ESTABLISHED IN COMMUNITY:** Profitable Farming Company  
Middle Barlington, Roborough  
Winkleigh, Devon, EX19 8AG  
ENGLAND

The person above certifies and declares that:

**VIRTUAL MACHINE:** Equipment mounted on a farm press and for the application of inoculants onto forage crops.

**MODEL:** 600RB-INST-17-Imp&Metric

**BRAND:** Harvest Tec

**SERIAL NUMBER:**

This application preservatives for hay Harvest Tec system meets the Directive 2006/42/EC of the European Parliament and the Council of 17 May 2006 and other applicable European Directives including Directive 2004/108/EC on the Electromagnetic compatibility.

The application of preservatives for hay Harvest Tec system will be turned on after being installed on a farm press has been declared in conformity with the Machinery Directive.

Person in the community authorized to provide information on the partly completed machinery and making this statement:

**Richard Snell, President, Profitable Farming Company**  
Signed on May 21, 2011: Middle Barlington, Roborough  
Winkleigh, Devon, EX19 8AG  
ENGLAND

# 600RB Installation Manual Table of Contents

	<b>Page</b>
<b>Introduction</b>	<b>4</b>
<b>System Requirements</b>	<b>4</b>
<b>Tools Needed</b>	<b>4</b>
<b>Installation of Moisture Sensor</b>	<b>5-14</b>
Installation of Dual Channel Processor (DCP)	5
Installation of Moisture Sensor Pads	6-14
Four Foot Wide Balers	6
Five Foot Wide Balers	7
John Deere 582	8
John Deere 854	8-9
John Deere Round Balers	10
Vermeer Balers	11
AGCO Baler Models – 5446,5456, 5545, 5546, 2745, 2746A, 2766	12
Challenger Baler Models– RB 46, 56	12
New Idea Baler Models – 6454, 6464, 6465	12
Massey Ferguson Baler Models – 2745, 2746, 2746A, 2756A, 2766, 2846, 2846A, 2856, 2856A, 2946, 2946A, 2956, 2956A	12 13
Installation of Bale Rate Timer Sensor	14
Installation of iPad Integration Control	15
iPad Integration Control Light Signals	15
Bluetooth Receiver Lights	15
<b>Wiring Diagram</b>	<b>16</b>
<b>Pin Outs</b>	<b>17-18</b>
<b>Troubleshooting</b>	<b>19</b>
<b>Parts Breakdown</b>	<b>20-23</b>
600RB Control and Harnesses	20
Moisture Pads and Touch Screen Display	21
Optional iPad Mini Mounting Kit	22
Optional iPad Display Kit	23
<b>Notes</b>	<b>24-26</b>
<b>Warranty</b>	<b>27</b>

## Introduction

Thank you for purchasing a Harvest Tec Model 600RB Moisture Monitor System. This 600RB Moisture Monitoring System has been designed to be operated through an Apple iPad (not included) using the Hay App. As well as the option to plug directly into most tractors that have an ISOBUS Monitor. The 600RB Moisture Monitoring System offers these advantages by operating through an Apple iPad:

1. Large bright, clear, colorful display
2. More durable and can be read in bright sunlight
3. Can be used for multiple other uses than just the applicator display
4. Option to tie-into the tractor ISOBUS system

The 600RB Moisture Monitor kit includes the following parts: Dual Channel Processor (DCP), Moisture Sensors, Harnesses. For your convenience a parts break down for the 600RB Moisture Monitoring System is included in the back of this manual. If you do have questions please bring this manual into the dealership. Right and Left sides are determined by facing in the direction of forward travel.

## System Requirements

**\*Made for iPad® (3<sup>rd</sup> through Pro 2<sup>nd</sup> generation), running the current iOS operating system or one version previous required for iPad option**

\*iPad is a trademark of Apple Inc., registered in the U.S. and other countries.

**\*\*600 Series Applicators with serial number before DCP27000 will require the DCP to be sent to Harvest Tec for a required update in order to use the iPad Integration Module (030-6672C).**

\*Hay App version must be **at least 2.5.18 (or higher)** to operate with the iPad Integration Module

*If choosing to operate the unit through the ISOBUS monitor, part number 006-6670A will need to be ordered through your local equipment dealer.*

## Tools Needed:

- Standard wrench set
- Electric drill and bits
- Side cutter
- Standard nut driver set
- Standard socket set
- Hammer
- Center punch

## Installation of Dual Channel Processor (DCP)

Select a mounting location for the DCP (006-6671RB) easily accessible that is away from moving parts and access panels. **Check before drilling to ensure nothing will be damaged on the opposite side of the DCP, some locations will be underneath baler doors.** After selecting the location for the DCP, mark and drill four 3/8" (10mm) holes to mount. In a location close to the DCP, a 1-1/2" (38mm) hole will need to be drilled and insert the supplied grommet. The 1-1/2" (38mm) hole will allow all the wires and harnesses to be attached to the DCP. Cover with DCP Shield 001-5650X (not shown). Below are recommended mounting locations on select baler models.



Mount DCP on Front of Baler



Mount DCP on Front of Baler



Mount DCP on Front of Baler



Mount DCP on Left Side of Bale Chamber Panel  
Above Baler Shelf

## Installation of Moisture Sensing Pads

### Four foot wide CNH balers (Pre 2015)

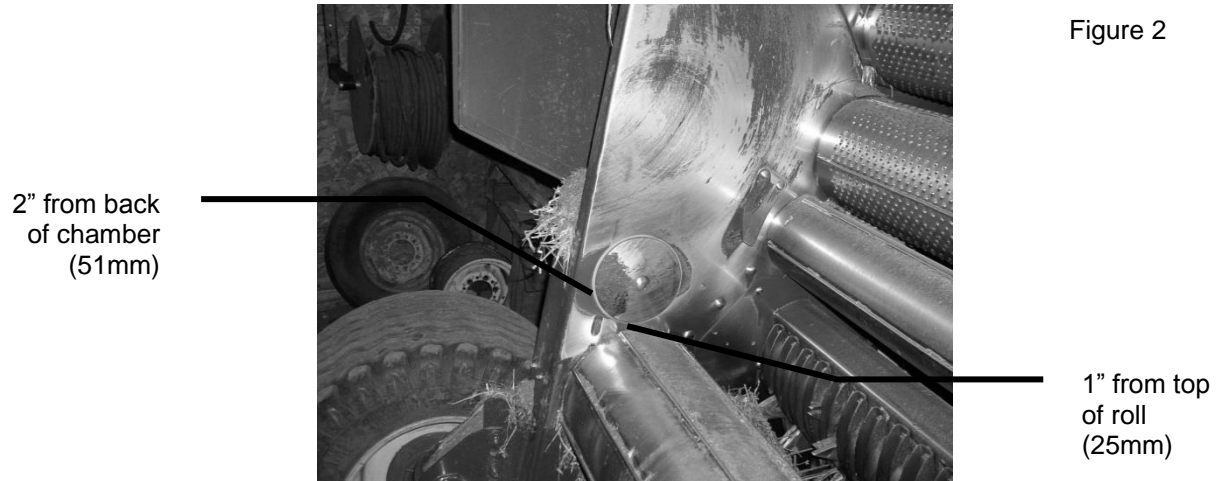

1. If your baler is equipped with bale shaping pads, remove disc and use existing hole that will need to be drilled out to 3/4" (19mm) to install new moisture sensing discs.
2. If your baler is not equipped with bale shaping pads you will need to drill a hole in the chamber directly behind and above the starting roll. (Figure 2)
3. The mounting hole will be 3/4" (19mm) in diameter. Use a plastic pad (006-4641F) and place it into the baler to use as a template. The bottom edge of the pad will be placed 1" up from starting roll and 2" (51mm) from the back of the bale chamber.

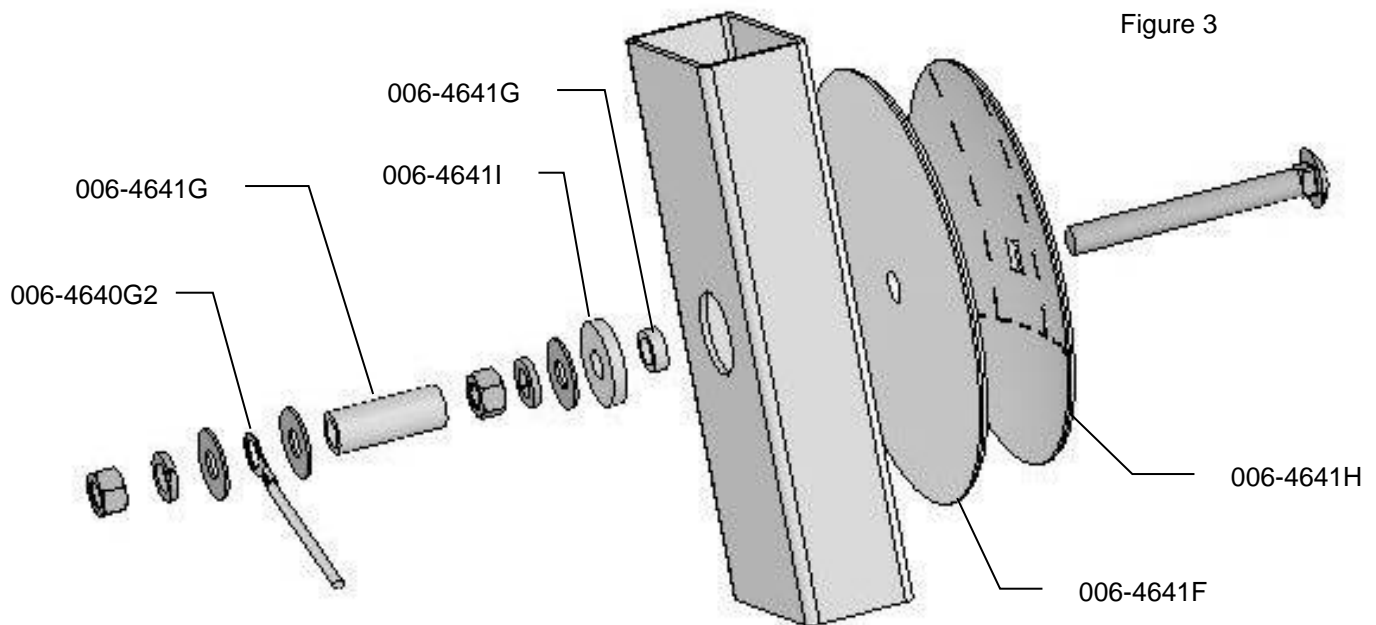

4. Locate the 006-4641G. The piece will need to be cut down to size. Use the already machined line in the bushing to cut off the small piece shown above. (Figure 3)
5. Depending on the baler the bolt may need to be trimmed for proper fit.
6. Make sure that the plastic pad is protecting all metal surfaces of the disc from touching baler.
7. Tighten all of the hardware to 50 ft/lbs (68 N/m).
8. Run the moisture wire harness (006-4640G2) from DCP to each disc securing with cable ties.
9. Apply silicone over nuts and washers.

## Installation of Moisture Sensing Pads (continued)

### Five foot wide CNH balers (Pre 2015)



1. If your baler is equipped with bale shaping pads, remove disc and use existing hole that will need to be drilled out to 3/4" (19mm) to install new moisture sensing discs. If the discs are welded, the welds will need to ground off for disc removal.
2. If your baler is not equipped with bale shaping pads you will need to drill a hole in the chamber directly behind and above the starting roll. (Figure 4)
3. The mounting hole will be 3/4" (19mm) in diameter. Use a plastic pad (006-4641F) and place it into the baler to use as a template. The bottom edge of the pad will be placed 1" (25mm) up from starting roll and 2" (51mm) from the back of the bale chamber.

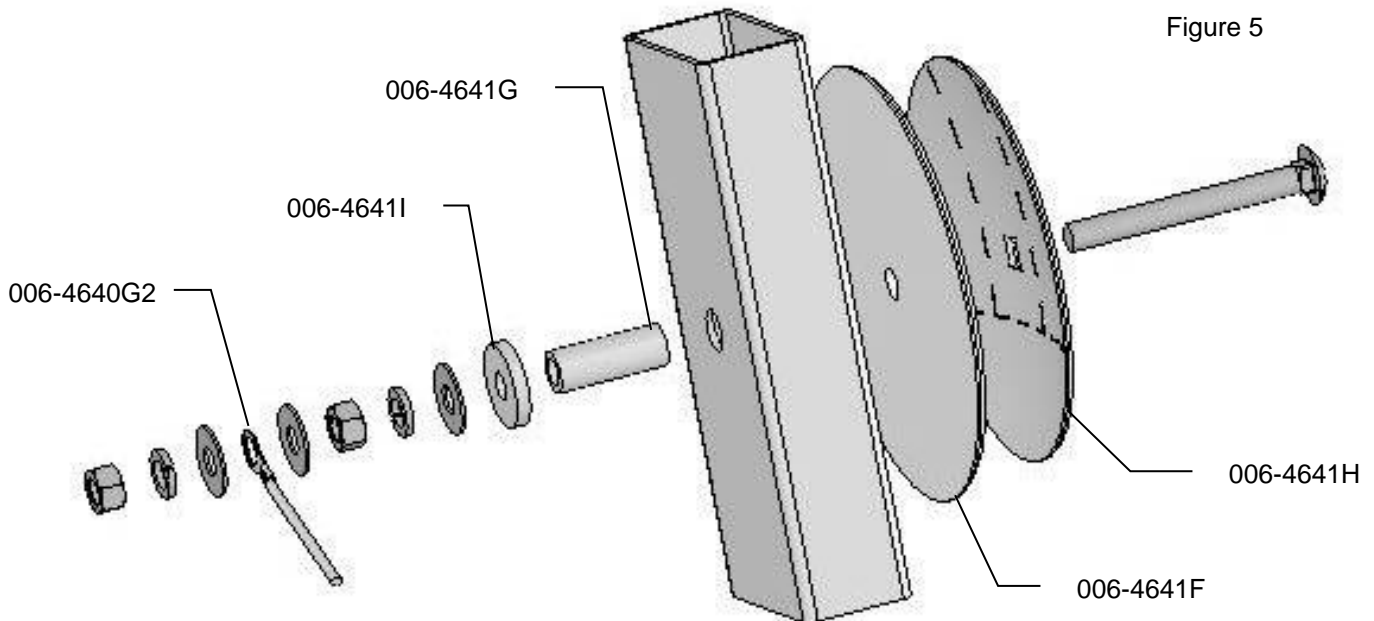

4. Locate the 006-4641G. The piece will need to be cut down to size. Use the already machined line in the bushing to cut off the small piece shown above. (Figure 5)
5. Make sure that the plastic pad is protecting all metal surfaces of the disc from touching baler.
6. Tighten all of the hardware to 50 ft/lbs (68 N/m).
7. Run the moisture wire harness (006-4640G2) from DCP to each disc securing with cable ties.
8. Apply silicone over nuts and washers.

## Install for John Deere 582

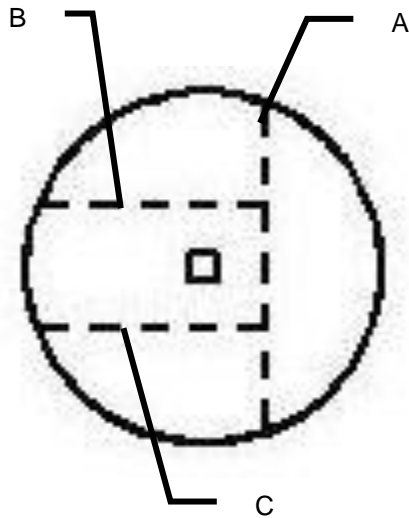

Figure 6

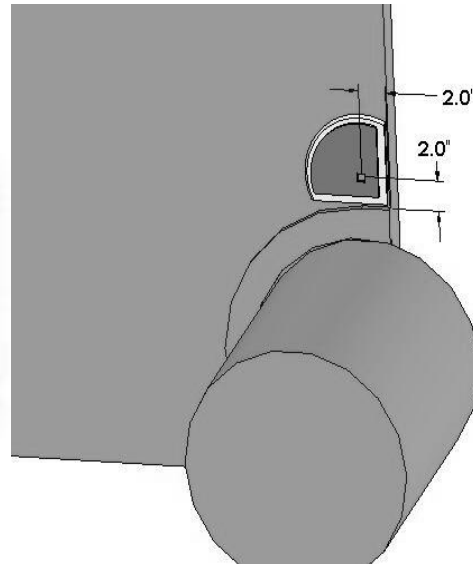

Figure 7

1. The moisture discs (006-4641H) will both need to be cut on line A. One disc will need to be cut on line B and one disc on line C. (Figure 6)
2. The plastic pad (006-4641F) will also need to be cut 1/4" longer than the back of the disc.
3. Bevel all sides of the cut discs to allow the smooth travel of crop over them.
4. The mounting hole will be 3/4" (19mm) in diameter. The disc will need to be placed on the baler to line up the location of 2" (51mm) up from bottom and 2" (51mm) from the back of the chamber to the center of the bolt. (Figure 7)

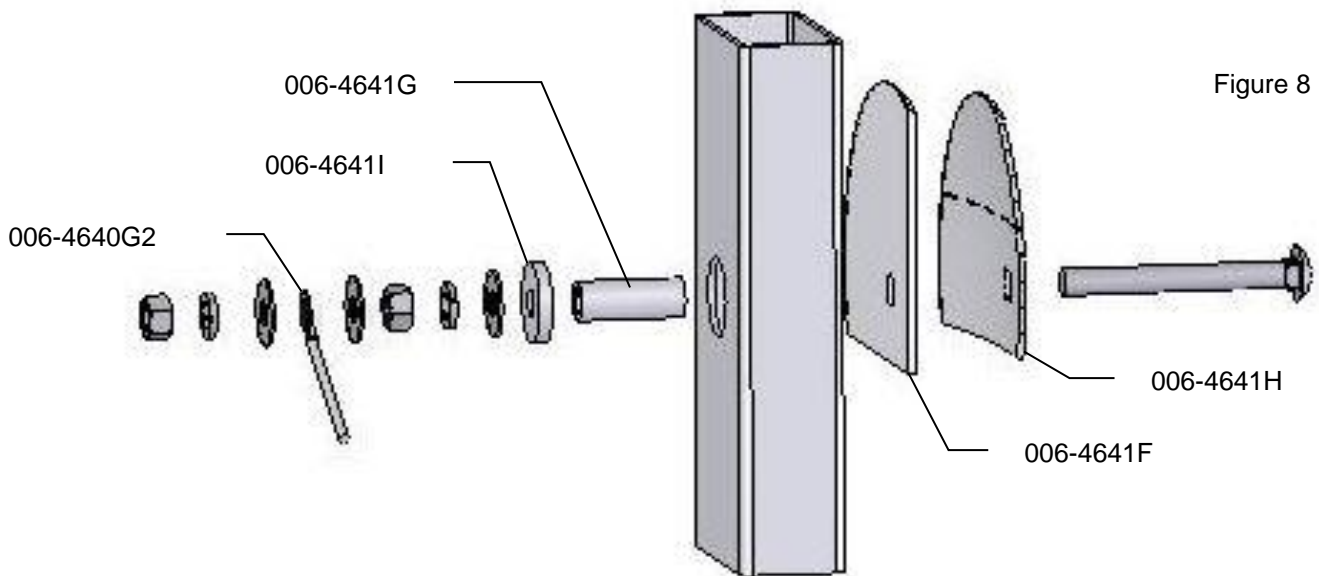

Figure 8

5. Make sure the plastic pad is protecting all metal surfaces of disc from touching baler.
6. Locate the 006-4641G. The piece will need to be cut down to size. Use the already machined line in the bushing to cut off the small piece shown above. (Figure 8)
7. Run the moisture wire harness (006-4640G2) from the DCP to each disc securing with cable ties.
8. On some balers the bolt may need to be trimmed for proper fit.
9. Tighten all hardware to 50 ft/lbs (68N/m), and apply silicone over nuts and washers.



## Install for John Deere 854

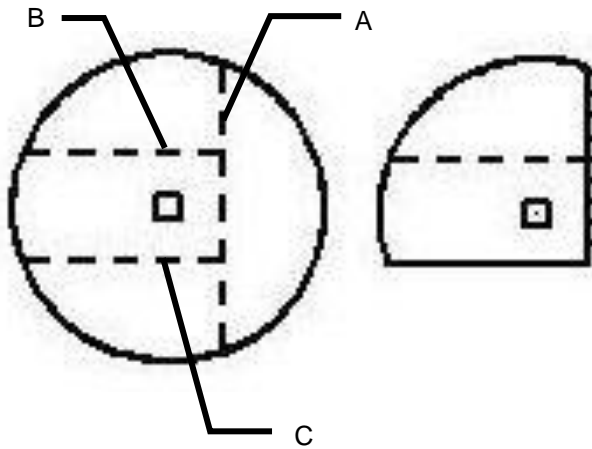

Figure 9

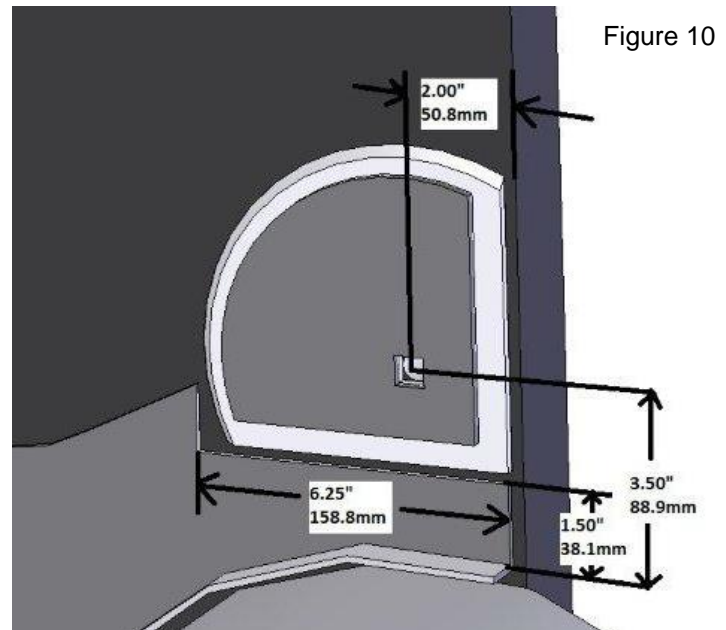

Figure 10

1. The moisture discs (006-4641H) will both need to be cut on line A. One disc will need to be cut on line B and one disc on line C. (Figure 9)
2. The plastic pad (006-4641F) will also need to be cut 1/4" (7mm) longer than the back of the disc.
3. Bevel all sides of the cut discs to allow the smooth travel of crop over them.
4. Remove the shield directly above the starter roll shown as figure D on both sides of the baler. Cut the 6.25" (16cm) notch out using the supplied measurements. Reinstall both sides.
5. The mounting hole will be 3/4" (19mm) in diameter. The disc will need to be placed on the baler to line up the location of 3.5" (89mm) up from bottom, 2" (51mm) from the back of the chamber to the center of the bolt. (Figure 10)

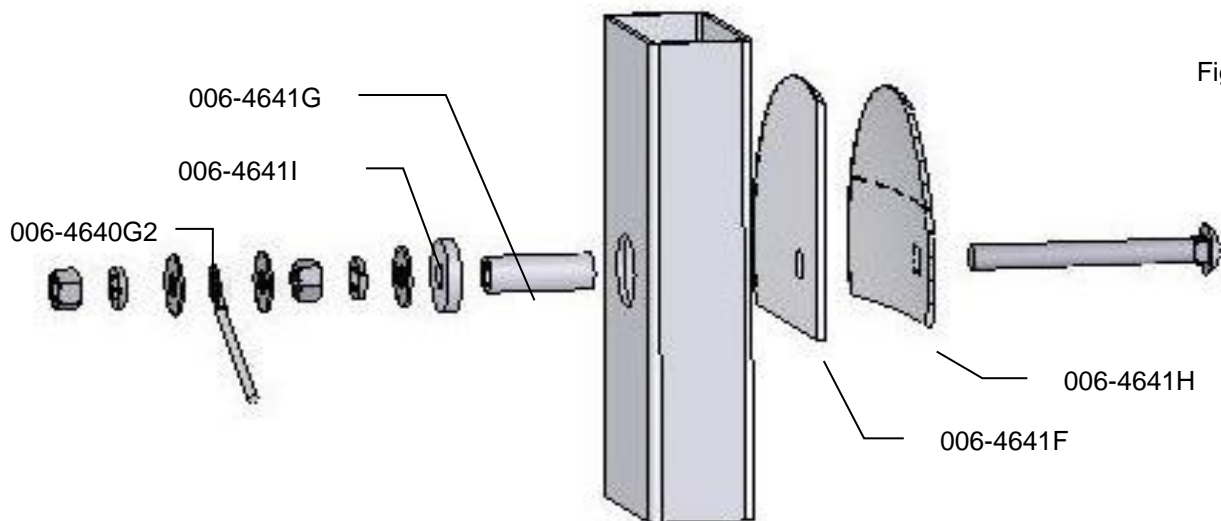

Figure 11

6. Make sure the plastic pad is protecting all metal surfaces of disc from touching baler.
7. Locate the 006-4641G. The piece will need to be cut down to size. Use the already machined line in the bushing to cut off the small piece shown above. (Figure 11)
8. Run the moisture wire harness (006-4640G2) from the DCP to each disc securing with cable ties.
9. On some balers the bolt may need to be trimmed for proper fit.
10. Tighten all hardware to 50 ft/lbs and apply silicone over nuts and washers

## Install for John Deere Round Balers

Figure 12

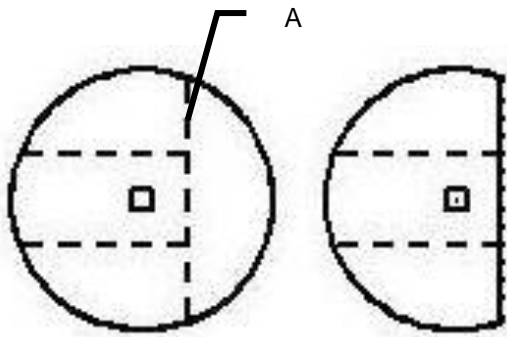
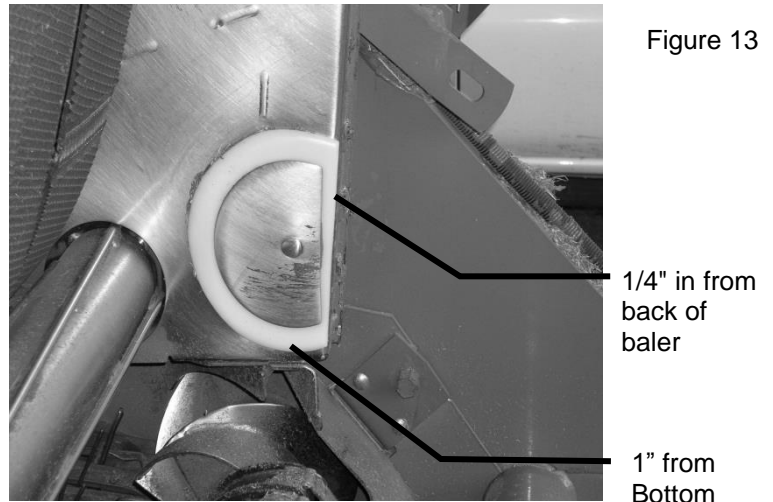
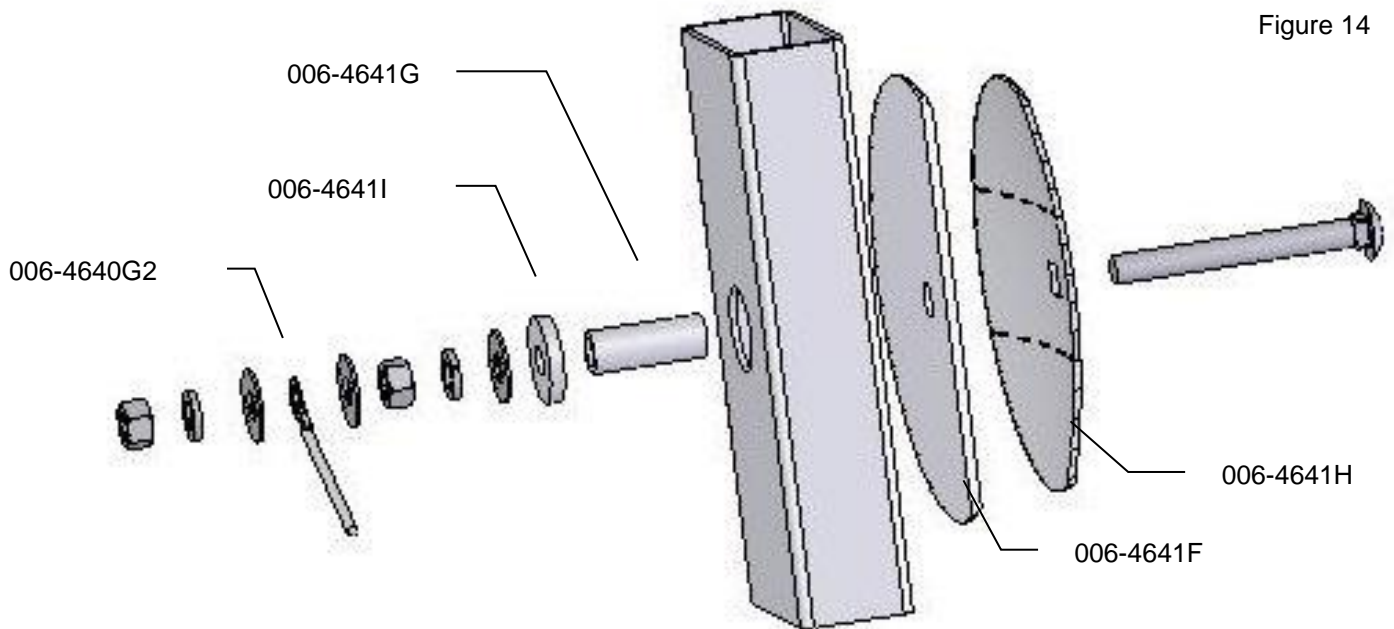

Figure 13



1. Both moisture discs (006-4641H) will need to be cut along the serrated line (A). Only cut on the line shown (Figure 12), do not cut the other line.
2. The plastic pad (006-4641F) will also need to be cut 1/4" (7mm) longer than the back of the disc.
3. Bevel all sides of the cut discs to allow the smooth travel of crop over them.
4. Using the cut disc as a pattern, mark and drill a 3/4" (19mm) hole in the side of the bale chamber. The disc will need to be placed on the baler 1" (25mm) up from bottom and 1/4" (7mm) in from back of the chamber.

Figure 14



5. Make sure that plastic pad is protecting all metal surfaces of disc from touching baler.
6. Run the moisture wire harness (006-4640G2) from the DCP to each disc securing with cable ties.
7. On some balers the bolt may need to be trimmed for proper fit.
8. Tighten all hardware to 50 ft/lbs (68N/m).
9. Apply silicone over nuts and washers.

## Install for Vermeer Balers



Figure 15

1. If your baler is equipped with bale shaping pads, remove disc and use existing hole (may need to be drilled larger, 3/4" (19mm) to install new moisture sensing discs.
2. If your baler is not equipped with bale shaping pads you will need to drill a hole in the chamber directly behind and above the starting roll. (Figure 15)
3. The mounting hole will be 3/4" (19mm) in diameter. Use a plastic pad (006-4641F) and place it into the baler to use as a template. The bottom edge of the pad will be placed 1" (25mm) up from starting roll and 2" (51mm) from the back of the bale chamber.

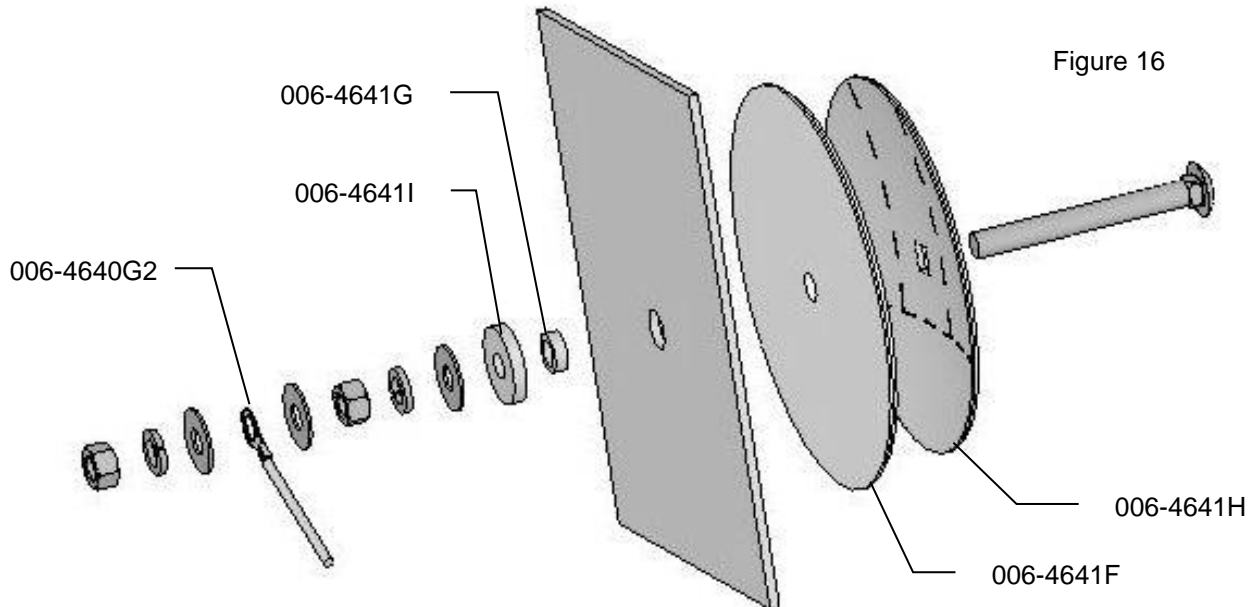

Figure 16

4. Locate the 006-4641G. The piece will need to be cut down to size. Use the already machined line in the bushing to cut off the small piece shown above. (Figure 16)
5. Depending on the baler the bolt may need to be trimmed for proper fit.
6. Make sure that the plastic pad is protecting all metal surfaces of the disc from touching baler.
7. Run the moisture wire harness (006-4640G2) from the DCP to each disc securing with cable ties.
8. Tighten all of the hardware to 50 ft/lbs (68 N/m). Apply silicone over nuts and washers.

**Install for AGCO (2700/5400/5500 Series), Challenger (RB 46/56)  
Massey Ferguson (2700 Series), New Idea (6454/6464/6465)**

1. If your baler is equipped with bale shaping pads, remove disc and use existing hole (may need to be drilled larger) to install new moisture sensing discs.
2. If your baler is not equipped with bale shaping pads you will need to drill a hole in the chamber directly behind and above the starting roll. (Figure 17)
3. Remove the main chain assembly and install the pad on the right side of baler. (Figure 18)
4. The hole size is 3/4" (19mm) diameter. Before drilling the hole make sure hole is accessible from opposite side of chamber to tighten down mounting hardware and install moisture harness. (Figure 19)
5. Make sure that the plastic pad is protecting all metal surfaces of disc from touching baler. (Figure 20)

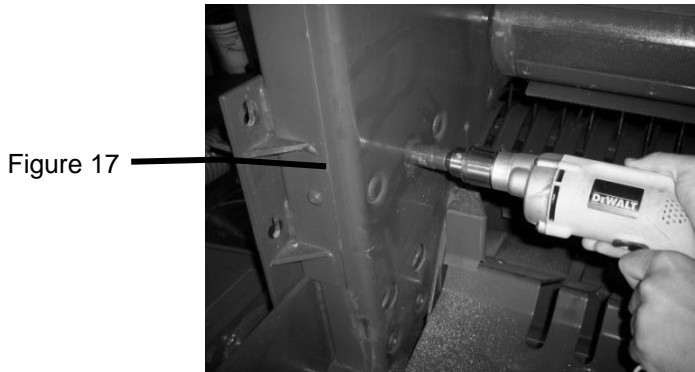

Figure 17



Figure 18



Figure 19



Figure 20

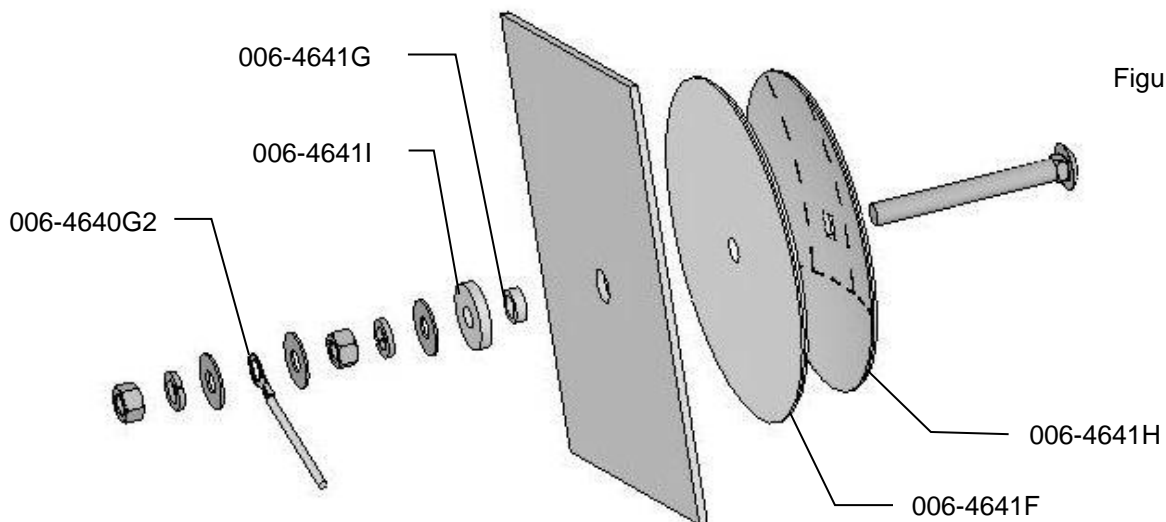

Figure 21

5. Locate the 006-4641G. The piece will need to be cut down to size. Use the already machined line in the bushing to cut off the small piece shown above. (Figure 21)
6. Depending on the baler the bolt may need to be trimmed for proper fit.
7. Run the moisture wire harness (006-4640G2) from the DCP to each disc securing with cable ties.
8. Tighten all of the hardware to 50 ft/lbs (68 N/m), and apply silicone over nuts and washers.

**AGCO & Massey Ferguson (2800/2900 Series)  
Challenger (3 Series/RB56C/RB56CA)**

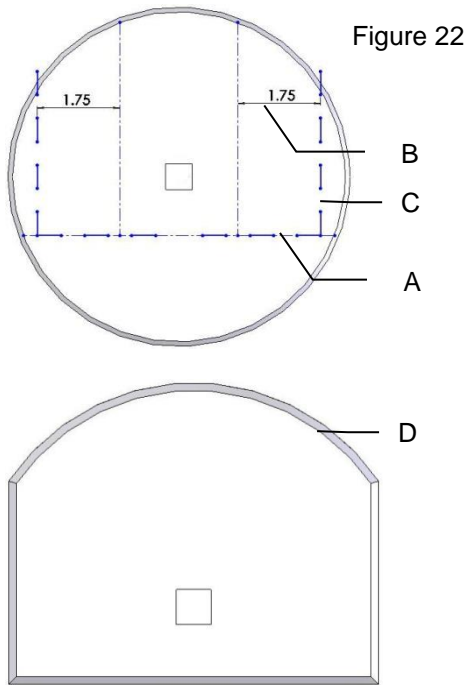

Figure 22

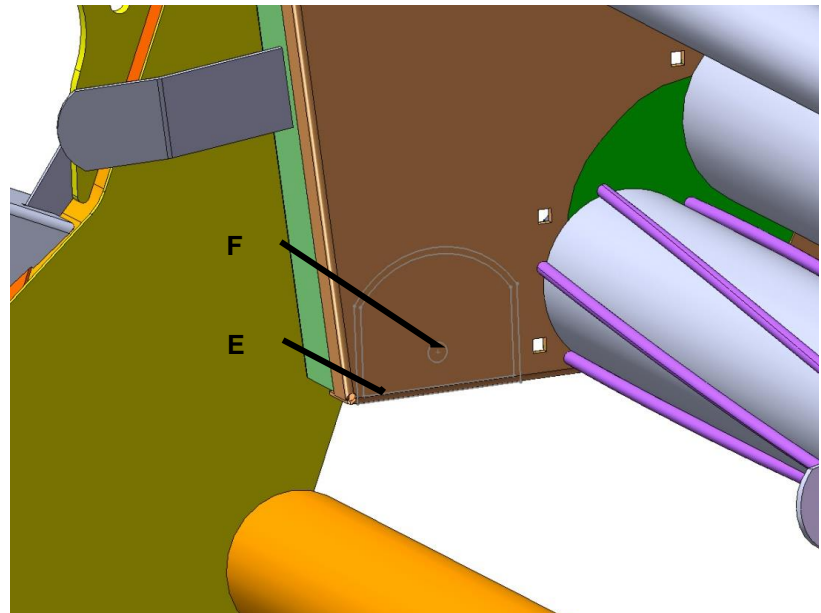

Figure 23

1. Both moisture discs (006-4641H) will need to be cut along the serrated line (A). (Figure 22) Measure from the laser etched line (B) 1.75 inches on both side. Mark and cut the disc. A completed disc is shown above (D).
2. The plastic pad (006-4641F) will also need to be cut 1/4" larger than the steel disc.
3. Bevel all sides of the cut discs to allow the smooth travel of crop over them.
4. Mark a line 1 1/2" (38mm) up and 3 1/2" (89mm) over from point (E). Drill a 3/4" (19mm) hole at the point (F). Repeat for the opposite side. (Figure 23)

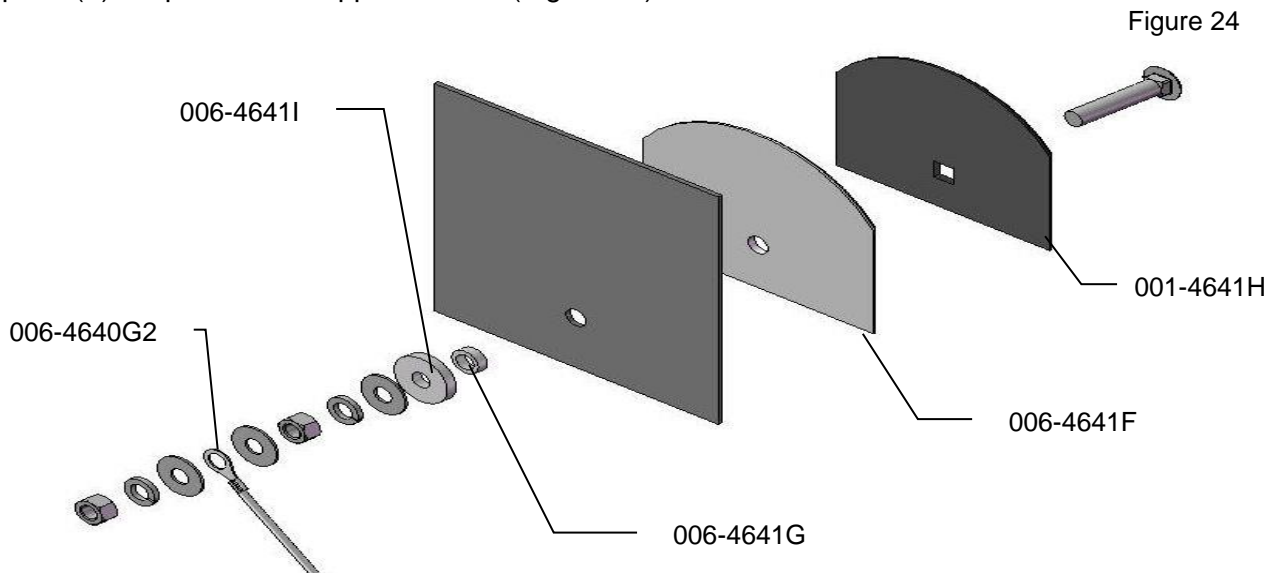

Figure 24

5. Locate the 006-4641G. The piece will need to be cut down to size. Use the already machined line in the bushing to cut off the small piece shown above. (Figure 24)
6. Depending on the baler the bolt may need to be trimmed for proper fit.
7. Make sure that the plastic pad is protecting all metal surfaces of the disc from touching baler.
8. Run the moisture wire harness (006-4640G2) from the DCP to each disc securing with cable ties.
9. Tighten all of the hardware to 50 ft/lbs (68 N/m), and apply silicone over nuts and washers.

## Installation of Bale Rate Timer Sensor

The bale rate timer sensor is used to determine when the baler door is open. With this information the system is able to change the tons/hour automatically. Refer to Operation Manual for Operation Instructions, Automatic Mode and also record information per bale.

Locate the sensor (006-7400) and the sensor bracket (001-4648RB). On the right side of the baler find a location 1"-6" (25mm-15cm) down from the hinge to mount the bracket. Check for clearance with hydraulic cylinders before mounting the bracket. The bracket should be mounted to the front side of the hinge point, with the sensor aligned over the back door. (Figure 25)

Mark and drill two 1/4" (7mm) holes and install the bracket using two 5/16" x 1-1/4" self-tapping bolts.

Install the sensor into the bracket and leave 1/4" (7mm) of clearance between the end of the sensor and door.

The harness will need to be routed towards the DCP. Secure with cable ties, be sure to avoid pinch points and hydraulic lines. The harness extension (006-7400EXT) may need to be used.

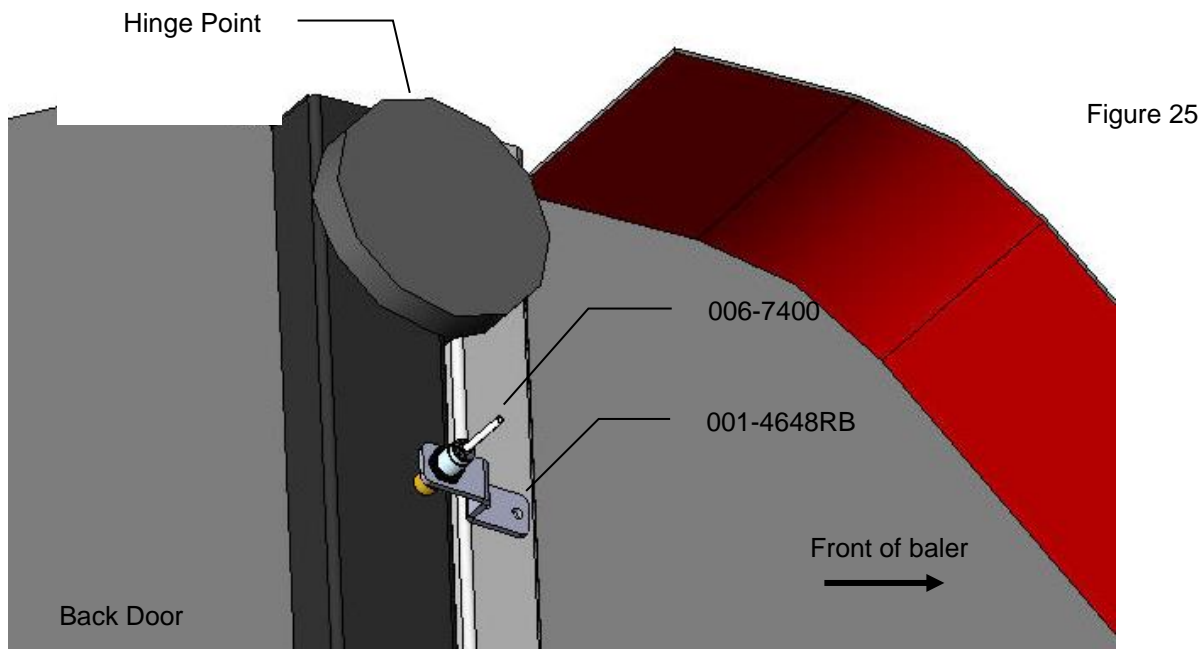

View of the right side of baler

## Installation of iPad Integration Control

Locate a safe location in the cab of the tractor to place the iPad Integration Control (030-6672C). Recommended location is securely fastened out of the operators way in a location that is close enough to reach with the iPad cord.

**Connect the Power / Communication harness (006-6650TM(E)) to the bottom of the receiver.**

To operate the applicator, plug the iPad cord into the communication port indicated by:

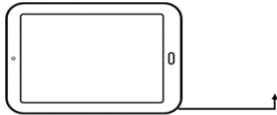

## iPad Integration Control Light Signals

Green Slow Blink – Power supplied to the applicator system and the unit is going through its startup process. This will take approximately 25-35 seconds.

Green Double Blink – Indicating the iPad module recognizes the iPad but the app is not open or connected.

Green Solid Light – Module is connected to the app and is ready to operate.

\*Recommended to use the USB cable included with the applicator kit (006-6672USBC)

## Bluetooth Receiver Lights

Pre-2020 applicators equipped with Bluetooth receivers (030-6672B) are now equipped with lights to indicate both power and Hay App connection on the Apple iPad. Clean light regularly

*Blinking Lights* – System is waiting for the processor to connect, which could take up to 35 seconds.

*Red Light* – The Bluetooth receiver has power

*Green Light* – The Bluetooth receiver is connected to the Hay App.



**\*\*600 Series Applicators with serial number before DCP27000 will require the DCP to be sent to Harvest Tec for a required update in order to use the iPad Integration Module (030-6672C).**

Hay App version must be **at least 2.5.18 (or higher)** to operate with the iPad Integration Module

## \*Made for Apple iPad badge

Use of the Made for Apple iPad badge means that an accessory has been designed to connect specifically to the Apple product(s) identified in the badge and has been certified by the developer to meet Apple performance standards. Apple is not responsible for the operation of this device or its compliance with safety and regulatory standards.

Please note that the use of this accessory with an Apple product may affect wireless performance.

## Wiring Diagram

- A. Locate the tractor power/communication harness (006-6650TM(E)).
- B. On the back of the tractor run the power leads to battery and the communication lead to ISOBUS plug.
- C. Connect the red power wire with the 50 amp fuse to the positive side of the battery (12 volt).
  - a. **The power harness must be connected to the battery!** The unit will draw more amps than convenience outlets can handle. Any modifications of the power harness will void systems warranty. **CONTACT HARVEST TEC IF MODIFICATION IS REQUIRED!**
  - b. **This unit will not function on positive ground tractors.**
  - c. **If the unit loses power while operating it will not record accumulated product used.**
- D. Connect the black ground wire to frame of tractor or negative side of battery (12 volt).
- E. Connect the baler power and communication harness (006-6650LS) to the power port on the DCP and to the display port on the DCP (006-6671RB).
- F. Install one terminating resistor to the pump controller connection on the DCP (006-5650Z).
- G. Attach moisture cable (006-4640G2(E)) to the DCP.
- H. Connect the iPad Integration Control (030-6672C) to the Communication Harness (006-6650TM(E))

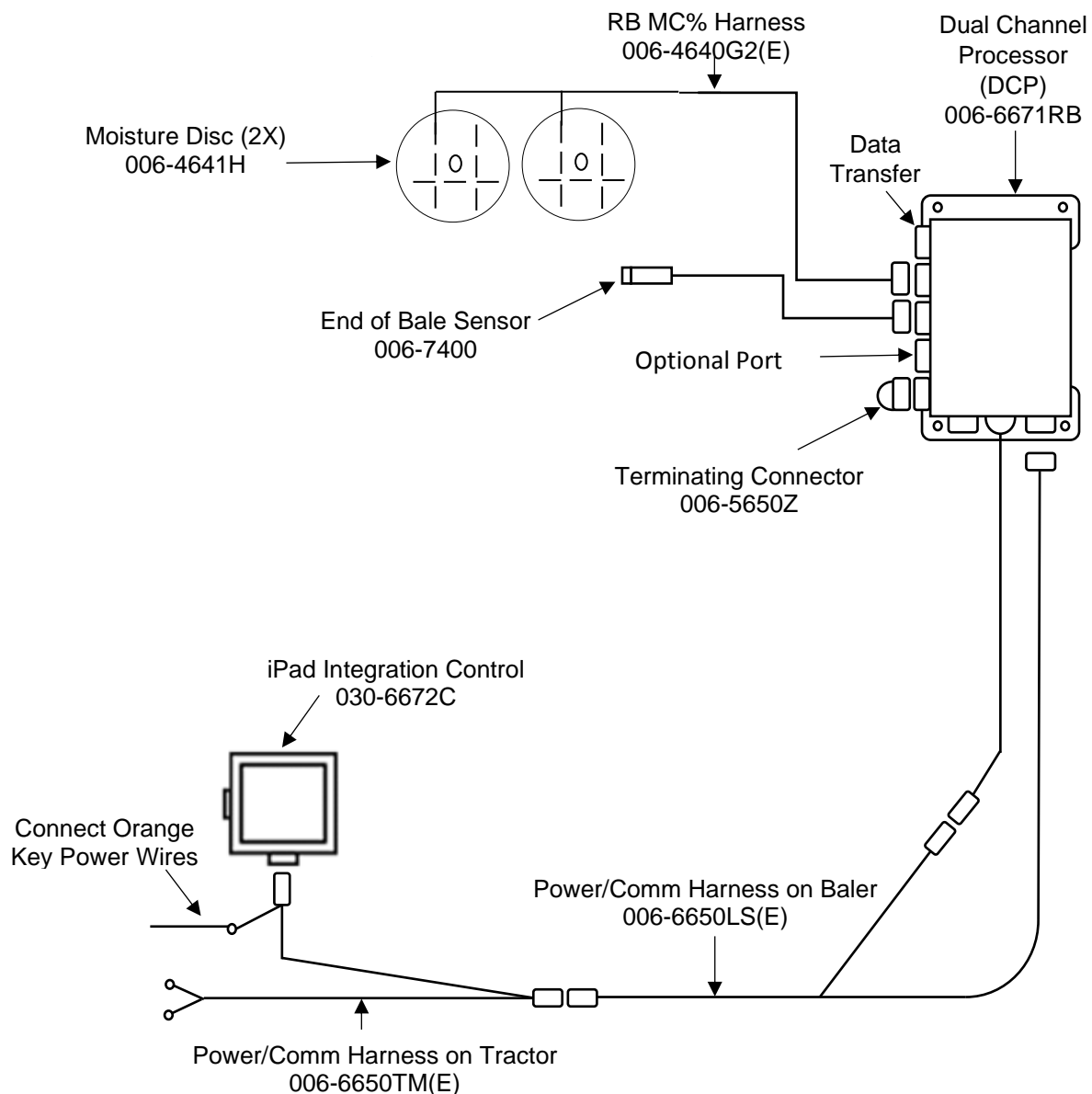

\*Note: (E) indication is used for International Dealers



## Pin Outs

### Power/Comm Harness 006-6650TM(E) at Hitch

Pin 1	Red	+12V Power to TSD
Pin 2	Red	+12V Power to DCP
Pin 3	Orange	Keyed Power
Pin 4	Gray	Shield
Pin 5	Green	HT Can Low
Pin 6	Yellow	HT Can Hi
Pin 7	Orange	Can1 Hi
Pin 8	Black	Ground from TSD
Pin 9	Black	Ground from DCP
Pin 10	Blue	Can1 Low



### Power/Comm Harness 006-6650LS(E) at Hitch

Pin 1	Red	+12V Power to TSD
Pin 2	Red	+12V Power to DCP
Pin 3	Orange	Keyed Power
Pin 4	Gray	Shield
Pin 5	Green	HT Can Low
Pin 6	Yellow	HT Can Hi
Pin 7	Orange	Can1 Hi
Pin 8	Black	Ground from TSD
Pin 9	Black	Ground from DCP
Pin 10	Blue	Can1 Low



### iPad Integration Control / BLE on Harness 006-6650TM(E)

Pin 1	Red	+12V Power from DCP
Pin 2	Black	Ground from TSD
Pin 3	Yellow	HT Can Low
Pin 4	Gray	Shield
Pin 5	Green	HT Can Hi
Pin 6	Orange	Can1 Hi
Pin 7	Blue	Can1 Low



### ISOBUS Plug 006-6670A Baler Side

Pin 1	N/A	
Pin 2	N/A	
Pin 3	120 OHM with Pin 5	
Pin 4	N/A	
Pin 5	120 OHM with Pin 3	
Pin 6	Orange	Can1 Hi
Pin 7	Blue	Can1 Low



### ISOBUS Plug Tractor Side

Pin 1	N/A	
Pin 2	N/A	
Pin 3	+12V Keyed Tractor Power	
Pin 4	N/A	
Pin 5	N/A	
Pin 6	N/A	
Pin 7	N/A	
Pin 8	Orange	Can1 Hi
Pin 9	Blue	Can1 Low

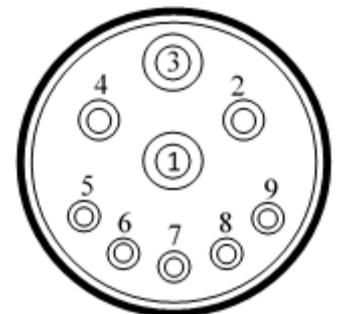

## Pin Outs (continued)

### Main Power Connector on DCP

Pin 1	Red	+12V Power from tractor
Pin 2	Black	Ground from tractor
Pin 3	Orange	Keyed power

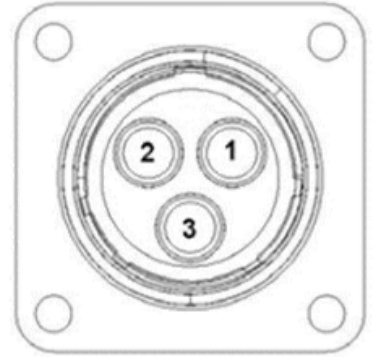

### Star Wheel and Bale Rate Sensor connector on DCP

Pin 1	Blue	+12V Power
Pin 2	Orange	Ground
Pin 3	Black	Signal for sensor 1
Pin 4	White	Signal for sensor 2
Pin 5	N/A	
Pin 6	N/A	
Pin 7	N/A	
Pin 8	Violet	Star wheel input 1
Pin 9	Brown	Star wheel input 2



### End of Bale sensor on DCP

Pin 1	Brown	Sensor Power
Pin 2	Blue	Sensor Ground
Pin 3	N/A	
Pin 4	Black	Signal from Sensor

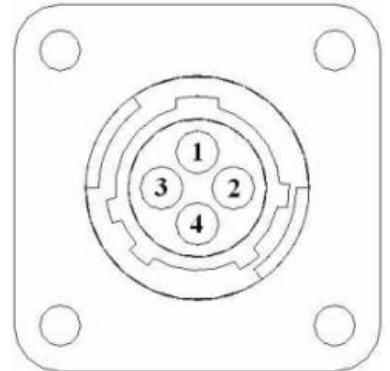

## Troubleshooting

PROBLEM	POSSIBLE CAUSE	SOLUTION
Moisture reading errors (high or low)	1. Wire disconnected or bad connection between star wheels and DCP	1. Reconnect wire.
	2. Low power supply to DCP	2. Check voltage at box. (Min of 12 volts required.) See Diagnostics section of manual.
	3. Dry hay lower than 8% moisture or wet hay over 75%.	3. System reads 8-70% moisture.
	4. Ground contact with one or both star wheels and baler mounted processor.	4. Reconnect.
	5. Short in wire between star wheels and DCP.	5. Replace wire.
	6. Check hay with hand tester to verify.	6. Contact Harvest Tec if conditions persist.
Moisture readings erratic.	1. Test bales with hand tester to verify that DCP has more variation than hand tester.	
	2. Check all wiring connections for corrosion or poor contact.	2. Apply dielectric grease to all connections.
	3. Check power supply at tractor. Voltage should be constant between 12 and 14 volts.	3. Install voltage surge protection on tractors alternator.
Terminal reads under or over power.	1. Verify with multi-meter actual voltage. Voltage range should be between 12-14 volts.	1. Clean connections and make sure applicator is hooked to battery. See Diagnostics section of manual.
Bale rate displays zero.	1. Bale rate sensors are reversed. 2. Short in cable. 3. Damaged sensor. 4. Sensor too far from starwheel.	1. Switch the sensors next to the star wheel. 2. Replace cable. 3. Replace sensor. 4. Adjust gap between prox sensor and star wheel so it is 1/8-1/4" away.
Bluetooth Receiver lights will not illuminate	1. Bluetooth receiver not connected 2. Harness disconnected 3. Low power	1. Check connections and voltage. Minimum 12.5V needed.
	<p><i>Blinking Lights</i> – System is waiting for the processor to connect, which could take up to 35 seconds.</p> <p><i>Red Light</i> – The Bluetooth receiver has power</p> <p><i>Green Light</i> – When the proper active connection is selected in the Hay App menu, the green light will indicate connection with the iPad.</p>	

# Parts Breakdown for 600RB Series Control and Harnesses

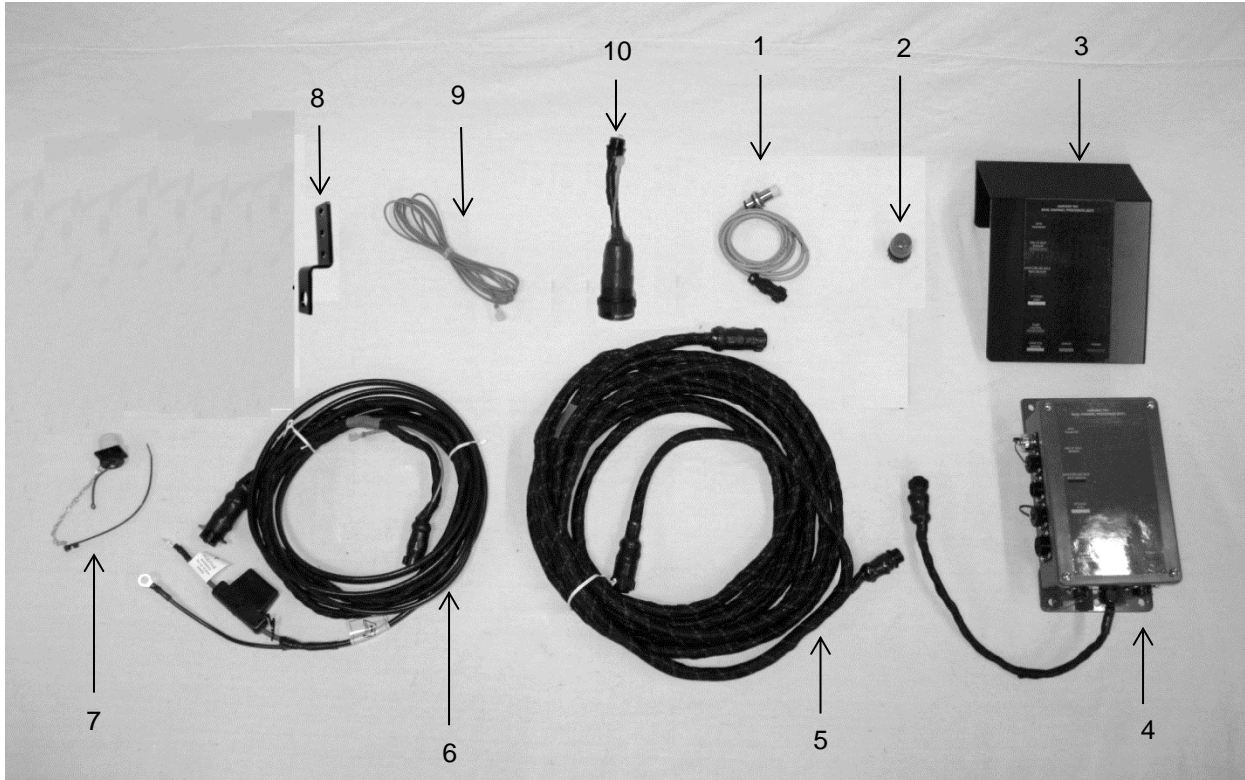

<u>Ref</u>	<u>Description</u>	<u>Part Number</u>	<u>Qty</u>
1	End Of Bale Sensor	006-7400	1
2	Terminating Connector w/ green cap	006-5650Z	1
3	DCP Shield/Cover	001-5650X	1
4	DCP Main Control LS 600 AUTO	006-6671RB	1
5	DCP Baler Harness 15 FT	006-6650LS(E)	1
6	DCP Tractor Harness	006-6650TM(E)	1
7	Dust Plugs	006-5651PLUGS	1
8	Round Baler End of Bale Bracket	001-4648RB	1
9	Key Switch Wire	006-5650K	1
10	Optional ISOBUS Tractor Plug (not included)	006-6670A	1
11	iPad Integration Control	030-6672C	1
NP	End of Bale Ext. Harness	006-7400EXT	1
NP	USB Cord	006-6672USBC	1

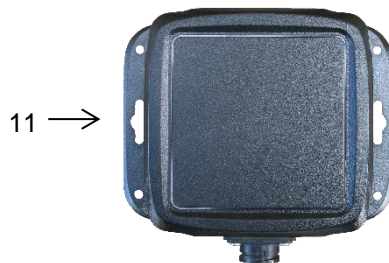

\*Note: (E) indication is used for International Dealers

# Moisture Pad and Touch Screen Display Parts Breakdown

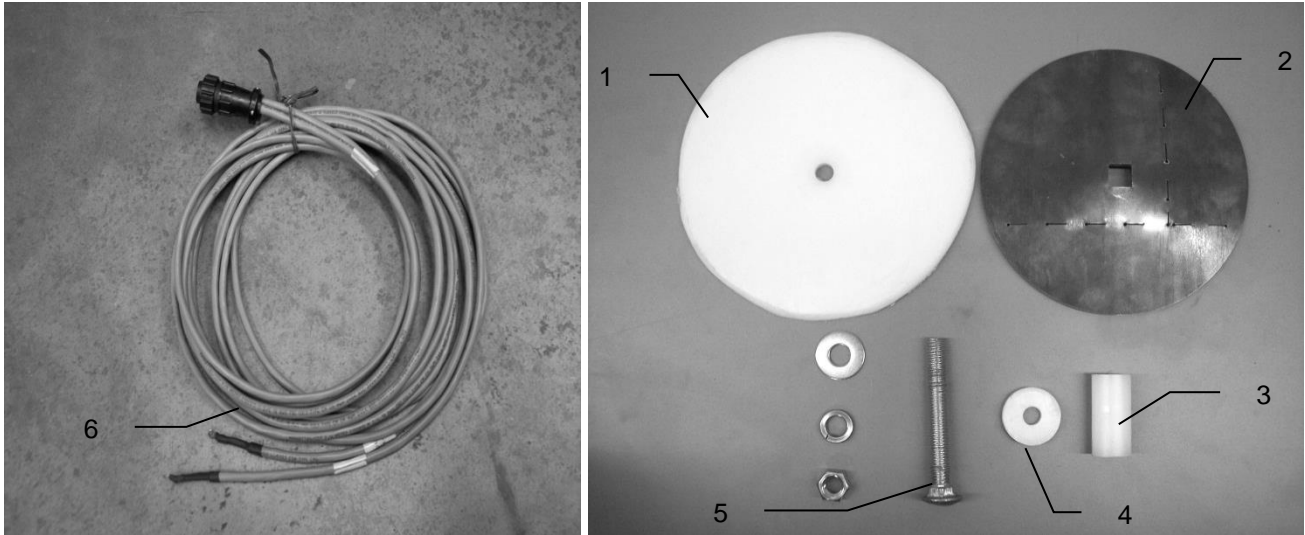

<u>Ref</u>	<u>Description</u>	<u>Part</u>	<u>Qty</u>
1	Plastic Pad	006-4641F	2
2	Moisture Disc	006-4641H	2
3	Plastic Bushing	006-4641G	2
4	Plastic Isolator	006-4641I	2
5	1/2X4 1/2" Carriage Bolt	Hardware	2
6	Moisture Cable	006-4640G2	1
1-5	Moisture Pad Assembly	030-4643	2

## Optional iPad Mini Mounting Kit (030-2014MK)

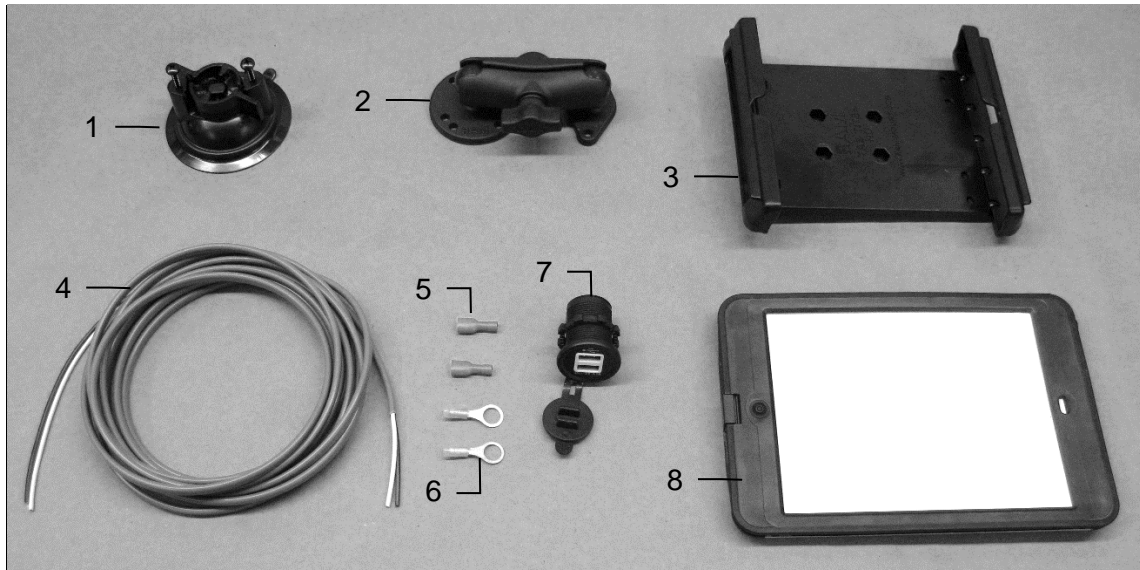

<u>Ref</u>	<u>Description</u>	<u>Part #</u>	<u>Qty</u>
1	Suction cup mount	001-2012SCM	1
2	Ram mount	001-2012H	1
3	iPad Mini® spring load cradle (Mini 4)	001-2012SLC	1
4	16 gauge power wire	006-4723P	1
5	Female spade connector	Hardware	2
6	Eye loop connector	Hardware	2
7	iPad Mini Charger 12V	001-2012P	1
8	iPad Mini 4 case	001-2012C4	1
NP	4 amp fuse	Hardware	1
Mounting Kit Assembly		030-2014MK (Includes All Parts)	

### Installation Instructions

1. Identify 12V power source for wires to connect.
  - a. Eye loops included if wiring directly to the battery is desired.
  - b. Test for key power source if preferred to have power to the USB shut off with the key.
2. Once power source is identified, cut wires to desired length.
3. Crimp the two supplied quick connectors onto each the white and black wire.
4. Remove the round locking plastic nut from USB plug before connecting the wires. Black (+) White (-).
5. The wires will then be hooked to the designated terminals on the bottom of the USB plug
6. Drill a 1 1/8" hole in the preferred mounting location. Be sure to clean any sharp edges after drilling.
7. Feed the wires through the mounting hole.
8. If using the round plastic nut to secure plug in place, slide the nut back over the wiring before connecting the wires to powered source.
9. Connect the wires to the identified power source if easier to do so before tightening the plug into place.
10. Tighten plug using either the round plastic nut or mounting plate and two screws, both options supplied.
11. Once connected, hook a USB charging cord into the plug and connect a mobile device/tablet to ensure the plug is operating as you wish (key power working properly if necessary).

NOTE: This plug is not designed to charge two iPads. System damage could occur if this is attempted. System will charge a mobile phone and iPad simultaneously without problem.

\*iPad mini is a trademark of Apple Inc., registered in the U.S. and other countries.

## Optional iPad Display Kit (030-4670DK)

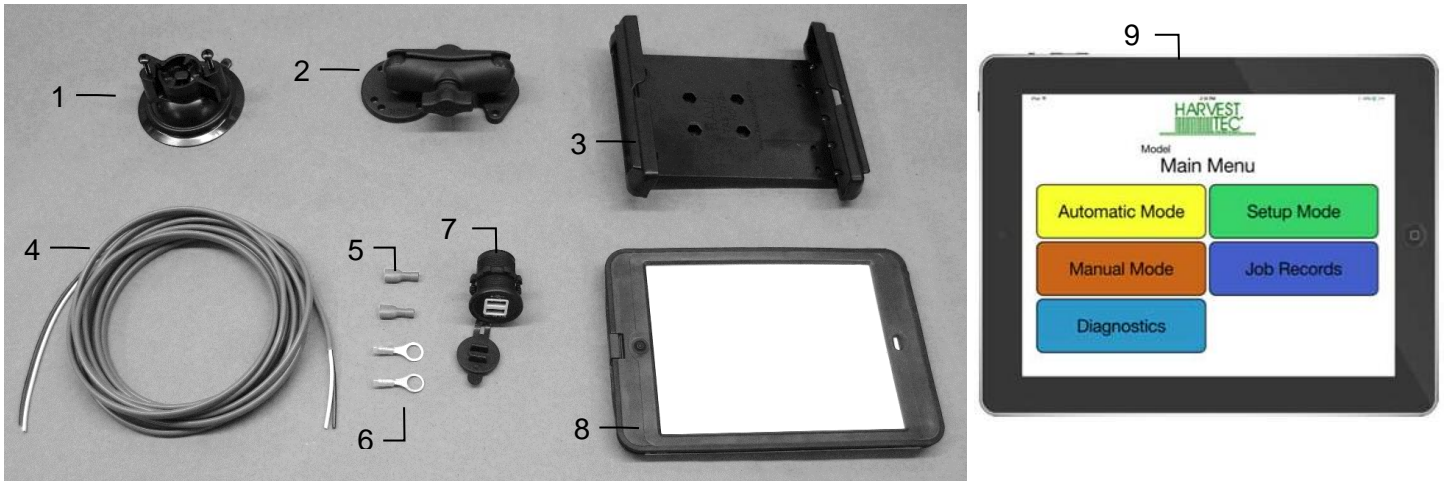

<u>Ref</u>	<u>Description</u>	<u>Part #</u>	<u>Qty</u>	<u>Ref</u>	<u>Description</u>	<u>Part #</u>	<u>Qty</u>
1	Suction cup mount	001-2012SCM	1	7	iPad Mini Charger 12V	001-2012P	1
2	Ram mount	001-2012H	1	8	iPad Mini 4 case	001-2012C4	1
3	iPad Mini® spring load cradle (Mini 4)	001-2012SLC	1	9	iPad Mini 4	006-4670IP	1
4	16 gauge power wire	006-4723P	1	NP	4 amp fuse	Hardware	1
5	Female spade connector	Hardware	2				
6	Eye loop connector	Hardware	2				
					Mounting Kit Assembly	030-4670DK (Includes All Parts)	

### Installation Instructions

1. Identify 12V power source for wires to connect.
  - a. Eye loops included if wiring directly to the battery is desired.
  - b. Test for key power source if preferred to have power to the USB shut off with the key.
2. Once power source is identified, cut wires to desired length.
3. Crimp the two supplied quick connectors onto the white and black wire.
4. Remove the round locking plastic nut from USB plug before connecting the wires. Black (+) White (-).
5. The wires will then be hooked to the designated terminals on the bottom of the USB plug
6. Drill a 1 1/8" hole in the preferred mounting location. Be sure to clean any sharp edges after drilling.
7. Feed the wires through the mounting hole.
8. If using the round plastic nut to secure plug in place, slide the nut back over the wiring before connecting the wires to powered source.
9. Connect the wires to the identified power source if easier to do so before tightening the plug into place.
10. Tighten plug using either the round plastic nut or mounting plate and two screws, both options supplied.
11. Once connected, hook a USB charging cord into the plug and connect a mobile device/tablet to ensure the plug is operating as you wish (key power working properly if necessary).

**NOTE: This plug is not designed to charge two iPads. System damage could occur if this is attempted. System will charge a mobile phone and iPad simultaneously without problem.**

\*iPad mini is a trademark of Apple Inc., registered in the U.S. and other countries.

# Notes



# Notes

# Notes

## **Harvest Tec Inc. Warranty and Liability Agreement**

Harvest Tec, Inc. will repair or replace components that are found to be defective within 12 months from the date of manufacture. Under no circumstances does this warranty cover any components which in the opinion of Harvest Tec, Inc. have been subjected to negligent use, misuse, alteration, accident, or if repairs have been made with parts other than those manufactured and obtainable from Harvest Tec, Inc.

Our obligation under this warranty is limited to repairing or replacing free of charge to the original purchaser any part that in our judgment shows evidence of defective or improper workmanship, provided the part is returned to Harvest Tec, Inc. within 30 days of the failure. If it is determined that a non-Harvest Tec branded hay preservative has been used inside the Harvest Tec applicator system where the failure occurred, then Harvest Tec reserves the right to deny the warranty request at their discretion. Parts must be returned through the selling dealer and distributor, transportation charges prepaid.

This warranty shall not be interpreted to render Harvest Tec, Inc. liable for injury or damages of any kind, direct, consequential, or contingent, to persons or property. Furthermore, this warranty does not extend to loss of crop, losses caused by delays or any expense prospective profits or for any other reason. Harvest Tec, Inc. shall not be liable for any recovery greater in amount than the cost or repair of defects in workmanship.

There are no warranties, either expressed or implied, of merchantability or fitness for particular purpose intended or fitness for any other reason.

This warranty cannot guarantee that existing conditions beyond the control of Harvest Tec, Inc. will not affect our ability to obtain materials or manufacture necessary replacement parts.

Harvest Tec, Inc. reserves the right to make design changes, improve design, or change specifications, at any time without any contingent obligation to purchasers of machines and parts previously sold.

Revised 4/17

**HARVEST TEC, INC.**  
**P.O. BOX 63**  
**2821 HARVEY STREET**  
**HUDSON, WI 54016**  
PHONE: 715-386-9100  
1-800-635-7468  
FAX: 715-381-1792  
Email: [info@harvesttec.com](mailto:info@harvesttec.com)