

Installation Manual

Model 696J ***110 Gallon Preservative Applicator***



*Equipment and Products
for Quality Hay.™*

P.O. Box 63 • 2821 Harvey Street • Hudson, WI 54016
800-635-7468 • www.harvesttec.com

(intentionally blank)

Harvest Tec Model 696J Installation Table of Contents

	<u>Page</u>
Introduction	4
System Requirements & Tools Needed	4
Installation of Applicator	5-10
Tank & Saddle Installation	5
Dual Channel Processor (DCP) Installation	5
Star Wheel Installation	6
End of Bale Sensor Installation	7
Drain / Fill Kit Installation	7
Spray Shield Installation	8
Plumbing	8
Baler Harness Routing and ISOBUS Connection	9
Installation of iPad Integration Control	10
iPad Integration Control Light Signals	10
Bluetooth Receiver Lights	10
Wiring Diagram	11
Pin Outs	12-14
Parts Breakdown	15-21
Tank, Saddle & Legs	15
Pump Manifold	16
Star Wheel & Bale Rate Sensors	17
Hose & Drain Fill Kit	17
Controls and Harnesses	18
4525JB Installation Kit	19
Optional iPad Mini Mounting Kit	20
Optional iPad Display Kit	21
Notes	22
Warranty Statement	23

Introduction

Thank you for purchasing a Harvest Tec Model 696J Hay Preservative Applicator. This 696J applicator system has been designed to plug directly into the baler's ISOBUS system and display on the ISOBUS monitor. The system can also be operated through an Apple iPad (not included) using the Hay App. The 696J Applicator System offers these advantages when running through the ISOBUS virtual terminal:

1. Operation coordinated with baler operation
2. Less cab clutter providing better visibility
3. Ease of use with all information on one screen
4. Records kept together
5. The system is ready for future updates.

The 696J Hay Preservative Applicator System is designed to apply buffered propionic acid to the forage crop as it is baled and will adjust the rate of application based on moisture and tonnage of the crop being harvested. The model 696J base kit includes: tank, frame, pumps, hose, and the Dual Channel Processor (DCP). This manual will take you through the steps for installing the applicator. If you are unsure about installing the system after consulting this manual, contact your local authorized dealership for additional assistance. If you are in need of parts for the system please see the parts breakdown in the back of this manual and contact your local authorized dealer to order the parts. This applicator is designed to apply Harvest Tec buffered propionic acid.

Right and Left sides are determined by facing in the direction of forward travel.

System Requirements

***Made for iPad® (3rd through Pro 2nd generation), running the current iOS operating system or one version previous required for iPad option**

*iPad is a trademark of Apple Inc., registered in the U.S. and other countries.

****600 Series Applicators with serial number before DCP27000 will require the DCP to be sent to Harvest Tec for a required update in order to use the iPad Integration Module (030-6672C).**

*Hay App version must be **at least 2.5.18 (or higher)** to operate with the iPad Integration Module

If choosing to operate the unit though the ISOBUS monitor, part number 006-6670A will need to be ordered through your local equipment dealer.

Tools Needed:

- | | | |
|---------------------------|---------------------------|-----------------------|
| - Standard wrench set | - Crescent wrench | - Standard socket set |
| - Electric drill and bits | - Standard screwdriver | - Hammer |
| - Side cutter | - Standard nut driver set | - Metal cutting tools |
| - Hose cutter | - Center punch | |

Installation of Applicator

Tank & Saddle Installation

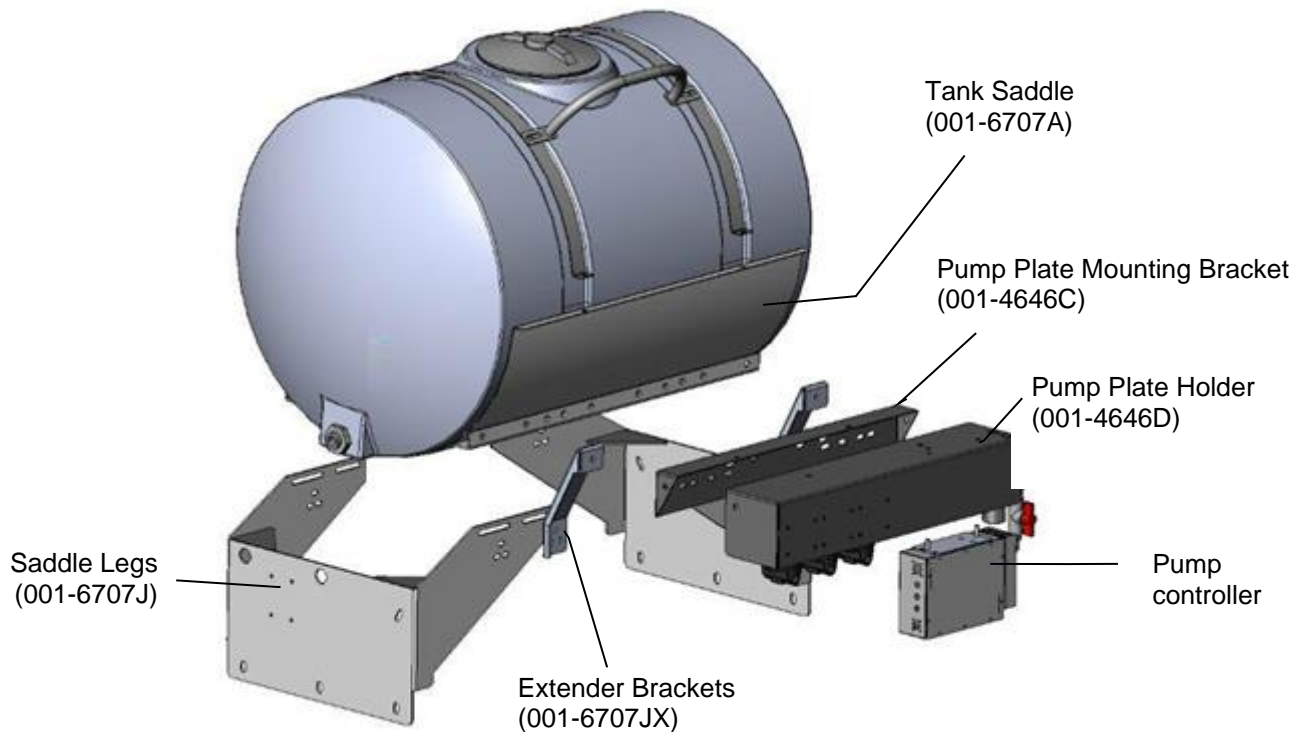

3x3 and 3x4 Balers

Locate parts bag 4. Prior to mounting the assembly onto the back of the bale chamber, install both saddle legs (001-6707J) loosely onto the saddle (001-6707A) with six 3/8" x 1-1/4" bolts, locks and flat washers. The mounting slots in the legs will attach to the second and fourth weld nuts in from each end, of the saddle, on both sides.

1. The tank legs bolt to the sides of the chamber on each side with three 1/2" x 1-3/4" carriage bolts, using existing holes in the chamber. Tighten the legs to the chamber prior to centering the tank saddle and tightening the legs to the saddle.
2. Install the pump plate by attaching the extender brackets (001-6707JX) to the legs.
3. Connect the pump plate mounting bracket (001-4646C) to the extender brackets, using 3/8" x 3/4" flange head bolts (x2), flat washer (x2), and 3/8" flange nuts (x2).
4. Attach the pump plate holder (001-4646D) to the pump plate mounting bracket (001-4646C) using four 3/8" x 3/4" flange head bolts.

Dual Channel Processor (DCP) Installation

John Deere L330 / L340 Baler DCP location on the back of the right twine box will vary slightly depending on placement of safety decals from factory. Do not cover safety decals. Mount DCP on the back of right hand twine box using Figure 1 as a reference. DCP location is recommended 5" (12.5cm) from inside edge and 5" (12.5cm) from top of twine box.

Figure 1



Star Wheel Installation

Remove any material from the bale chute. The star wheels are to be mounted on the transition bracket on both sides of the bale chute located after knotters shown above. Holes have been installed at the factory, however you need to remove bracket and cut 3/4" (19mm) off the bracket as indicated below to allow proper spacing for star wheel assembly.

Once complete, touch up with spray paint to prevent rusting and place the carriage bolts that mount the transition bracket back in original bracket mounting holes (A) before mounting star wheel assembly (C). Insert the 5/16" x 3 1/4" Allen head bolts up through the transition bracket and use nuts to hold the bolts in place (B). Place the star wheel block over the nuts. Place twine guard on top of star wheel (D), the guard containing bale rate sensors will be placed on the right side. Note: Thicker part of star wheel block should be on baler side.

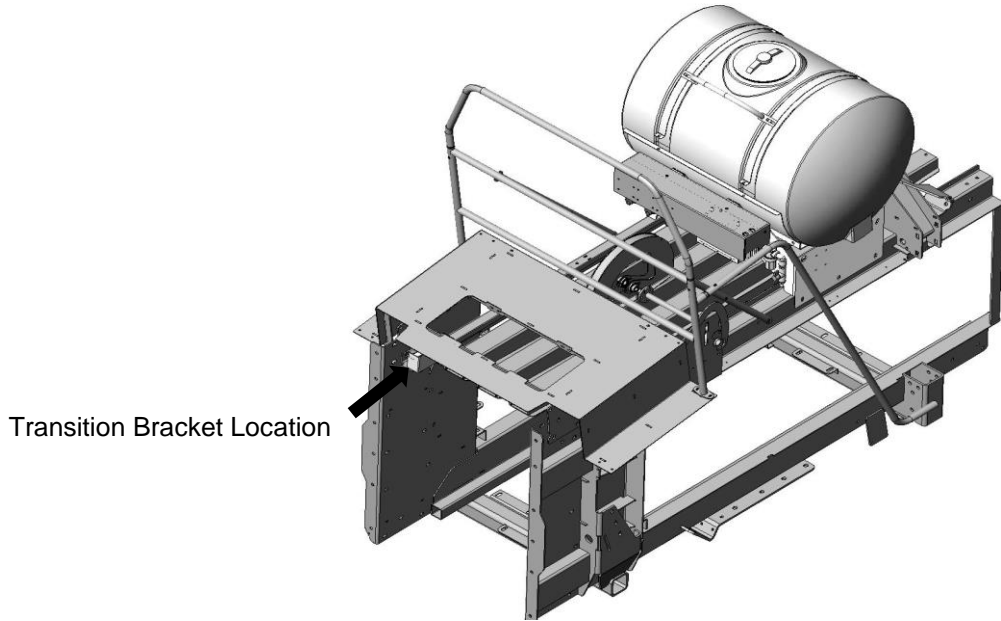

Cut 3/4" Off Bracket

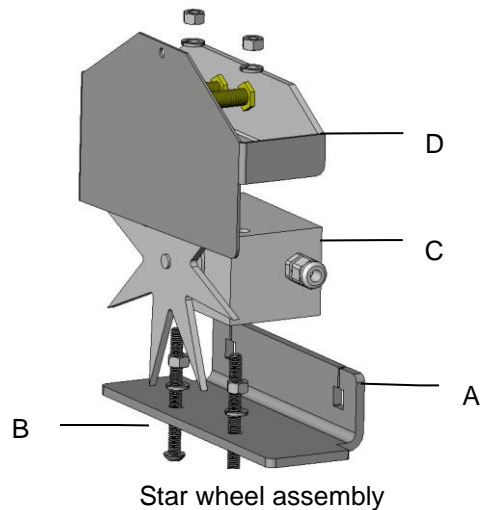
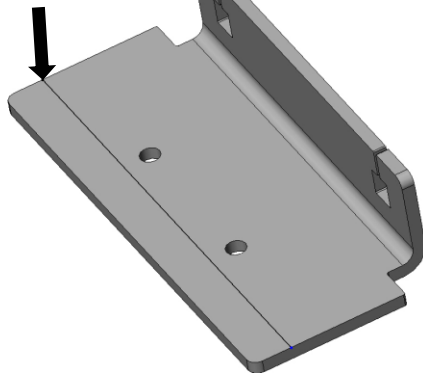

End of Bale Sensor Installation

The end of bale sensor determines the position of the needles on the baler. When the needles cycle the sensor communicates this information to the Dual Channel Processor (DCP). This information is used for job records and will be used by the optional Bale Identification System. Follow the steps below for your baler to mount the sensor.

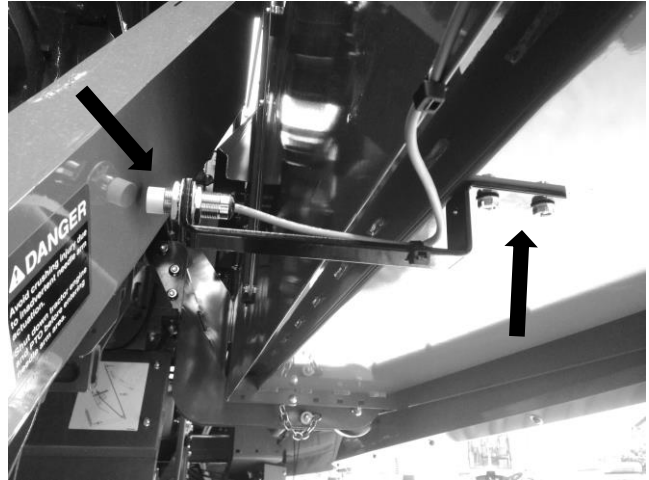
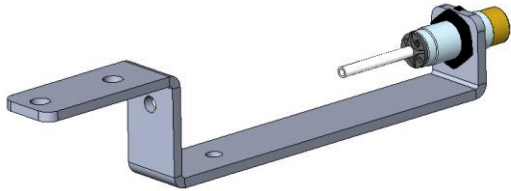

Mount the end of bale sensor bracket (001-4648J) as shown. Under the twine box mark and drill two 3/8" (10mm) holes and attach the bracket using two 5/16" x 1" self-tapping screws, and 5/16" flange nuts. Position the bolts so the bolt heads are inside the twine box so they don't interfere with the twine. Mount the sensor in hole location centered alongside the needle arm, keep the sensor 1/4" (7mm) from the needle arm and tighten both nuts. Route the sensor wire along the bottom side of the twine box toward the twine box pivot point. Secure the wire to the twine box and around the pivot point to avoid damage to the wire. Once routed around the pivot point, connect the EOB sensor wire to the Dual Channel Processor (DCP).

Drain/Fill Line Installation

1. Locate parts bag 1.
2. Thread 3/4" elbow fitting into end of tank.
3. Run hose from the elbow down the frame to the bottom of the baler.
4. Drill 1/4" (7mm) holes to accept the valve holder bracket and use 5/16" x 1" self-tapping screws.
5. Connect valve assembly to other end of hose. Place hose clamps on both ends.
6. Secure hose to frame using cable locks.
7. Install supplied safety decals (DCL-8001 & DCL-8005) next to the ball valve assembly.

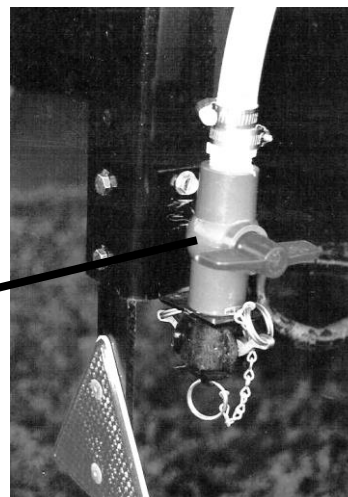

Spray Shield Installation

The spray shield assembly is designed to spray the hay evenly as the baler picks it up. A sketch of the spray shield nozzle holder is shown below.

Tip Outputs

High Output Tips for Rates Requiring 84-632 lbs/hr. Approximately 21-63 tons/hr (38-287 L/hr)

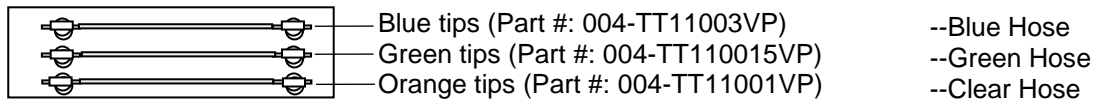

Low Output Tips for Rates Requiring 44-400 lbs/hr. Approximately 11-40 tons/hr (20-150 L/hr)

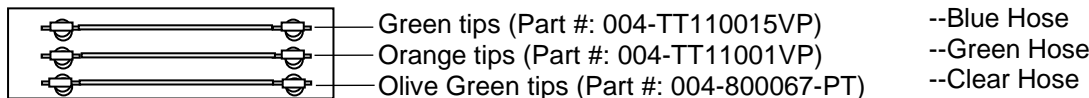

Installation Kit 4525JB

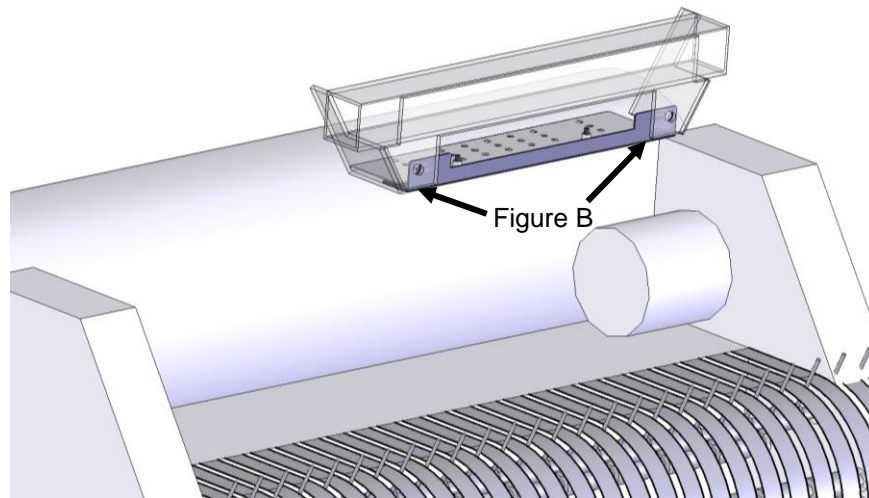

Locate the two bolts shown in Figure B. Remove bolts and install spray shield holder (001-4435EJ). Install bolts and tighten. Install spray shield assembly (001-4435ES) and secure with two supplied lynch pins. Use the inside nozzle holes spaced 10" (25cm) apart on 3x3 balers and the outside nozzle holes on 3x4 balers.

Plumbing

- A. Locate the three 1/4" hoses colored clear, blue, and green. The pumps will need to be connected to specific tips so the pump numbers are as follows: Pump 1 is closest to the filter bowl, pump 2 is in the middle, and pump 3 is the outside pump.
- B. Slide the jaco nut over the end the hose and insert the hose into the jaco fitting and tighten the jaco nut. Because all nozzles on the spray shield are different, the operator will need to install pump 1 to the orange tips using the clear hose, pump 2 to the green tips using the green hose and pump 3 to the blue tips using the blue hose.
- C. **KEEP HOSE AWAY FROM: MOVING PARTS, SHARP METAL, AND HYDRAULIC LINES. WORKING TEMPERATURE FOR THE HOSE IS 140 °F AND UNDER.**
- D. Tie the hose down at secure locations on the baler using the enclosed tie straps and cable clamps.

John Deere L330 / L340 Balers Harness Routing and ISOBUS Connection

A. Main wiring harness and power cord connection to baler harness terminator connection



Route cords 006-6650LS2 along this path. Keep cords away from moving parts and hydraulic hoses. Secure with existing cable clamps or use cable ties. When all connections are made to DCP secure wires as shown below.

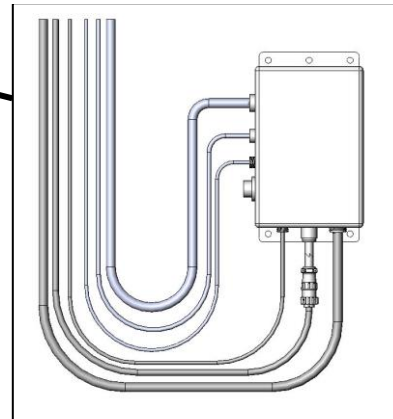

B. Route for mounting harness and hoses from DCP and Pumps

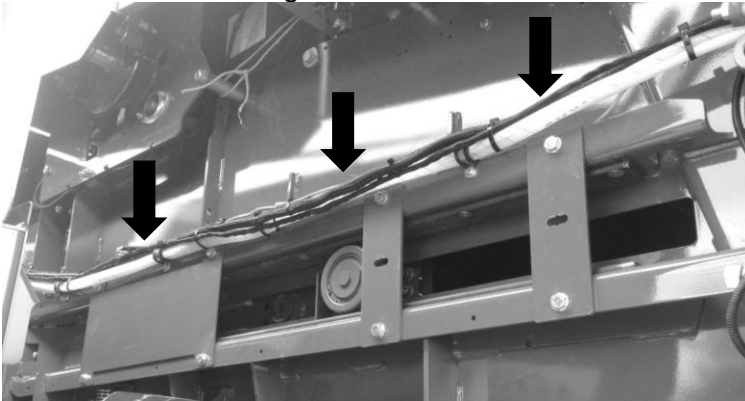

C. Route ISO Integration Harness (006-6650VAJ) to opposite side of baler through support cylinder.

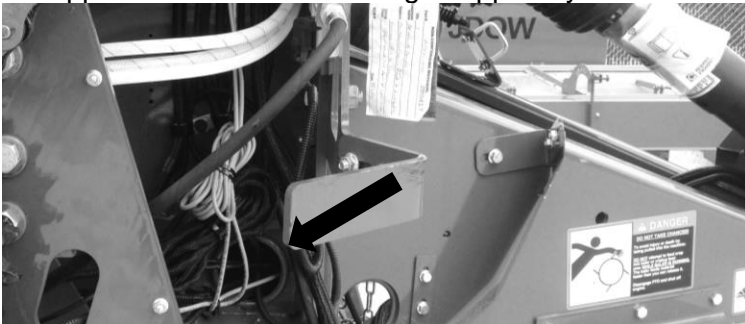

D. ISOBUS Connection

Locate harness 006-6650VAJ and connect to baler interface harness next to baler's processor (below) on front left side of baler.

Remove baler terminating resistor and connect to short pigtail on 006-6650VAJ Harness.



Installation of iPad Integration Control

Locate a safe location in the cab of the tractor to place the iPad Integration Control (030-6672C). Recommended location is securely fastened out of the operators way in a location that is close enough to reach with the iPad cord.

Connect the Power / Communication harness (006-6650TM(E)) to the bottom of the receiver.

To operate the applicator, plug the iPad cord into the communication port indicated by:

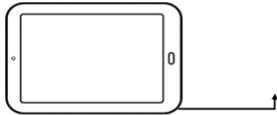

iPad Integration Control Light Signals

Green Slow Blink – Power supplied to the applicator system and the unit is going through its startup process. This will take approximately 25-35 seconds.

Green Double Blink – Indicating the iPad module recognizes the iPad but the app is not open or connected.

Green Solid Light – Module is connected to the app and is ready to operate.

*Recommended to use the USB cable included with the applicator kit (006-6672USBC)

Bluetooth Receiver Lights

Pre-2020 applicators equipped with Bluetooth receivers (030-6672B) are now equipped with lights to indicate both power and Hay App connection on the Apple iPad. Clean light regularly

Blinking Lights – System is waiting for the processor to connect, which could take up to 35 seconds.

Red Light – The Bluetooth receiver has power

Green Light – The Bluetooth receiver is connected to the Hay App.



****600 Series Applicators with serial number before DCP27000 will require the DCP to be sent to Harvest Tec for a required update in order to use the iPad Integration Module (030-6672C).**

Hay App version must be **at least 2.5.18 (or higher)** to operate with the iPad Integration Module

*Made for Apple iPad badge

Use of the Made for Apple iPad badge means that an accessory has been designed to connect specifically to the Apple product(s) identified in the badge and has been certified by the developer to meet Apple performance standards. Apple is not responsible for the operation of this device or its compliance with safety and regulatory standards.

Please note that the use of this accessory with an Apple product may affect wireless performance.

Wiring Diagram

- A. The Baler Power/Communication Harness (006-6650LS2) will attach to the open port of the Tractor Harness (006-6650TM) and run back to the Dual Channel Processor (DCP 006-6671LS).
- B. Connect the large plug of the Baler Power/Communication Harness (006-6650LS2) to the bottom (shorter side) of the DCP. Attach the Baler Interface Harness (006-6650VAJ) in between the short whip cable hardwired to the DCP and the main Power/Communication Harness. Make sure Active Terminator removed from the baler processor is attached to the Baler Interface Harness (006-6650VAJ).
- C. Install the Terminating Connector (006-5650Z) to the Modular Port on the Pump Controller (006-5672).
- D. Attach moisture and bale rate harness (006-7303H) to the DCP (006-6671LS).
- E. Attach the Pump Control Harness (006-5650FM) between the Pump Controller (006-5672) and the DCP (006-6671LS).
- F. Connect Keyed Power Extension harness (006-5650K) to a keyed power source.
- G. Connect iPad Integration Control (030-6672C) to Communication Harness (006-6650TM).
- H. Note: the Optional Port and the Data Transfer Port are not used in this application.

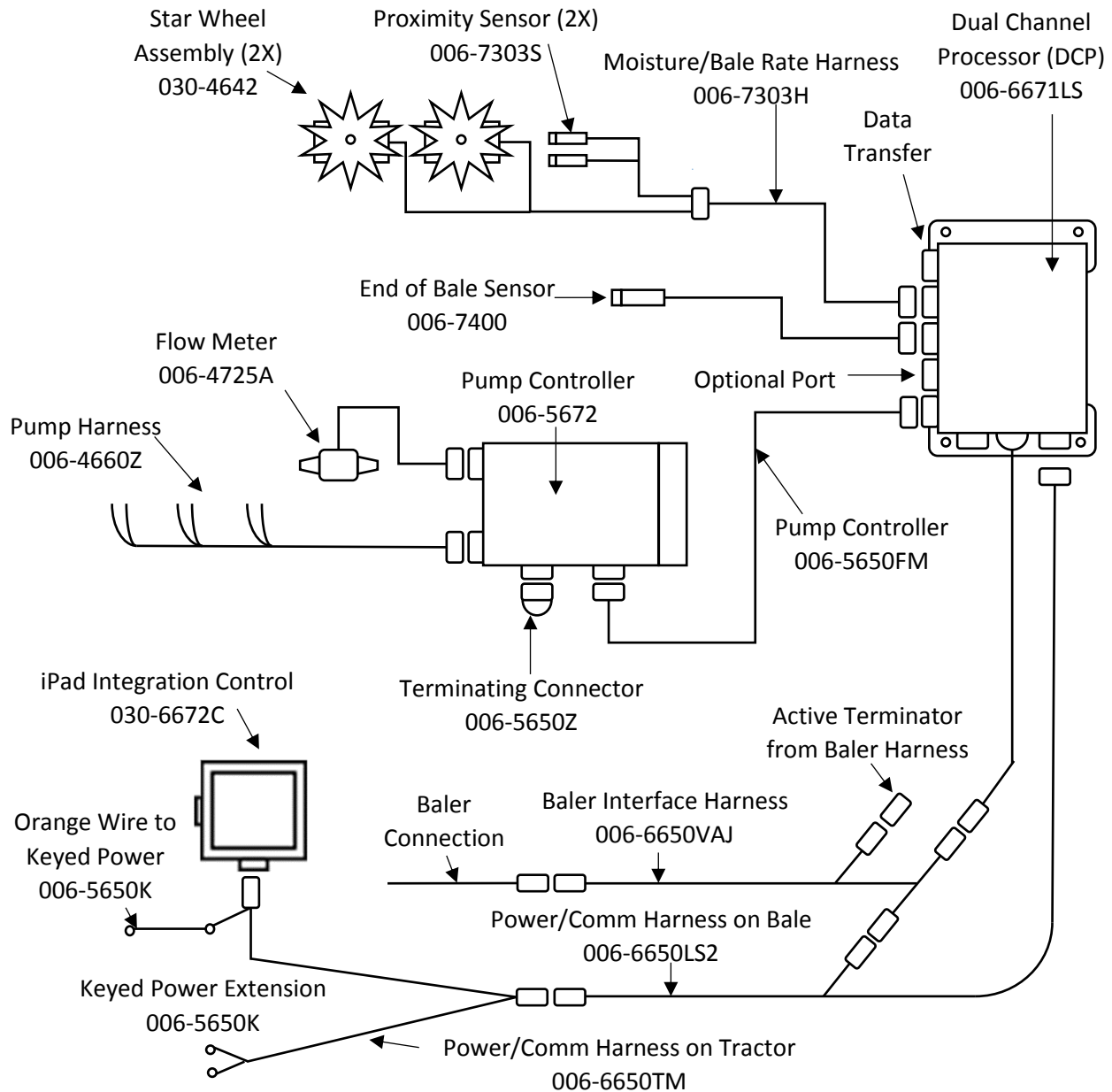

Pin Outs

Power/Comm Harness 006-6650TM at Hitch

Pin 1	Red	+12V Power to TSD
Pin 2	Red	+12V Power to DCP
Pin 3	Orange	Keyed Power
Pin 4	Gray	Shield
Pin 5	Green	HT Can Low
Pin 6	Yellow	HT Can Hi
Pin 7	Orange	Can1 Hi
Pin 8	Black	Ground from TSD
Pin 9	Black	Ground from DCP
Pin 10	Blue	Can1 Low



Power/Comm Harness 006-6650LS2 at Hitch

Pin 1	Red	+12V Power to TSD
Pin 2	Red	+12V Power to DCP
Pin 3	Orange	Keyed Power
Pin 4	Gray	Shield
Pin 5	Green	HT Can Low
Pin 6	Yellow	HT Can Hi
Pin 7	Orange	Can1 Hi
Pin 8	Black	Ground from TSD
Pin 9	Black	Ground from DCP
Pin 10	Blue	Can1 Low



iPad Integration Control / BLE on Harness 006-6650TM

Pin 1	Red	+12V Power from DCP
Pin 2	Black	Ground from TSD
Pin 3	Yellow	HT Can Low
Pin 4	Gray	Shield
Pin 5	Green	HT Can Hi
Pin 6	Orange	Can1 Hi
Pin 7	Blue	Can1 Low



ISOBUS Plug Baler Side

Pin 1	N/A	
Pin 2	N/A	
Pin 3	120 OHM with Pin 5	
Pin 4	N/A	
Pin 5	120 OHM with Pin 3	
Pin 6	Orange	Can1 Hi
Pin 7	Blue	Can1 Low



ISOBUS Plug Tractor Side

Pin 1	N/A	
Pin 2	N/A	
Pin 3	+12V Keyed Tractor Power	
Pin 4	N/A	
Pin 5	N/A	
Pin 6	N/A	
Pin 7	N/A	
Pin 8	Orange	Can1 Hi
Pin 9	Blue	Can1 Low

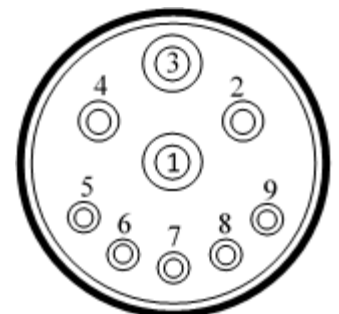

Pin Outs (continued)

Main Power Connector on DCP

Pin 1	Red	+12V Power from tractor
Pin 2	Black	Ground from tractor
Pin 3	Orange	Keyed power

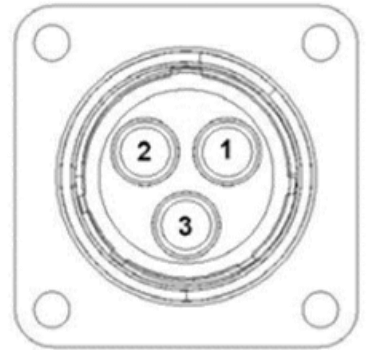

Star Wheel and Bale Rate Sensor connector on DCP

Pin 1	Blue	+12V Power
Pin 2	Orange	Ground
Pin 3	Black	Signal for sensor 1
Pin 4	White	Signal for sensor 2
Pin 5	N/A	
Pin 6	N/A	
Pin 7	N/A	
Pin 8	Violet	Star wheel input 1
Pin 9	Brown	Star wheel input 2



End of Bale sensor on DCP

Pin 1	Brown	Sensor Power
Pin 2	Blue	Sensor Ground
Pin 3	N/A	
Pin 4	Black	Signal from Sensor

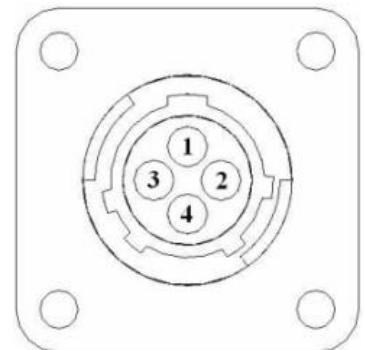

Pump Communication Plug on DCP

Pin 1	Red	+12V Can
Pin 2	Red	+12V Power
Pin 3	Gray	Shield
Pin 4	Green	Comm Channel OH
Pin 5	Yellow	Comm Channel OL
Pin 6	Blue	Comm Channel IH
Pin 7	Orange	Comm Channel IL
Pin 8	Black	Can Ground
Pin 9	Black	Power Ground
Pin 10	N/A	

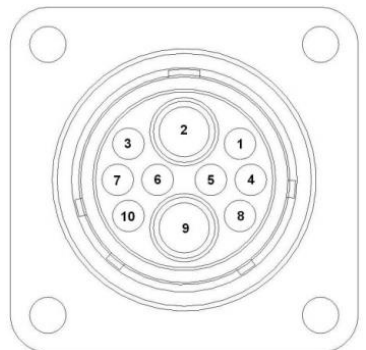

Pump Connection Colors

Pin 1	Black with Orange Stripe	Pump 1 Ground
Pin 2	Black with Green Stripe	Pump 2 Ground
Pin 3	Black with Yellow Stripe	Pump 3 Ground
Pin 4	N/A	
Pin 5	Orange with Black Stripe	Pump 1 Positive
Pin 6	Green with Black Stripe	Pump 2 Positive
Pin 7	Yellow with Black Stripe	Pump 3 Positive

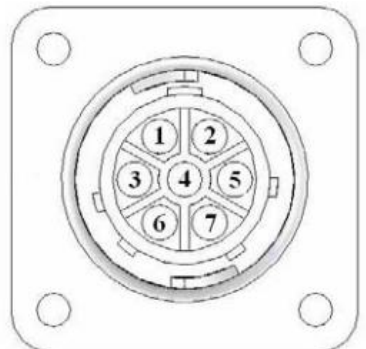

Pin Outs (continued)

Flow Meter Connection on Pump Controller

Pin 1	White	5 – 12V (+) Supply
Pin 2	Green	Ground
Pin 3	Brown	Signal
Pin 4	Black	Shield

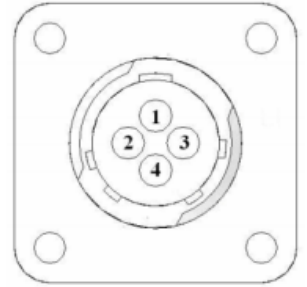

Connector for Crop Eyes on DCP

Pin 1	Red	+12V Power
Pin 2	Black	Ground
Pin 3	White	Signal
Pin 4	N/A	

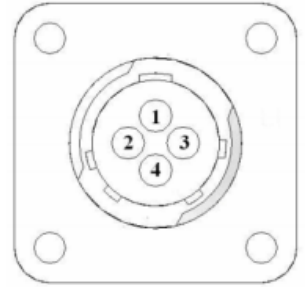

006-6650VAJ Harness to Baler Plug

Pin A	N/A	
Pin B	Red	TBC Power
Pin C	N/A	
Pin D	Gray	TBC Ground
Pin E	Orange	Can1 Hi
Pin F	Blue	Can1 Low

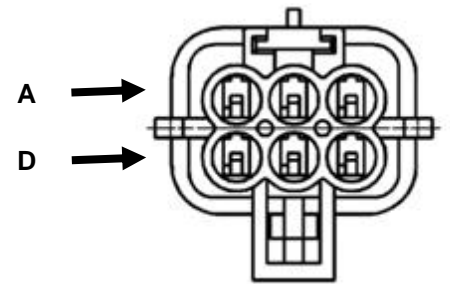

Parts Breakdown Tank, Saddle and Legs 110 Gallon



- Tank Lid**
Part#: 005-9022E
or 005-9208L
- Tank-110 gallon**
Part#: 005-9208
- Hand Rail**
Part#: 001-6707HR
- Tank Straps**
Part#: 001-4402B
- Tank Saddle**
Part#: 001-6707A
- Tank Fitting**
Part#: 005-9100

Not Pictured: Elbow
Part#:003-EL3412

John Deere L330 / L340

Part#: 001-6707J

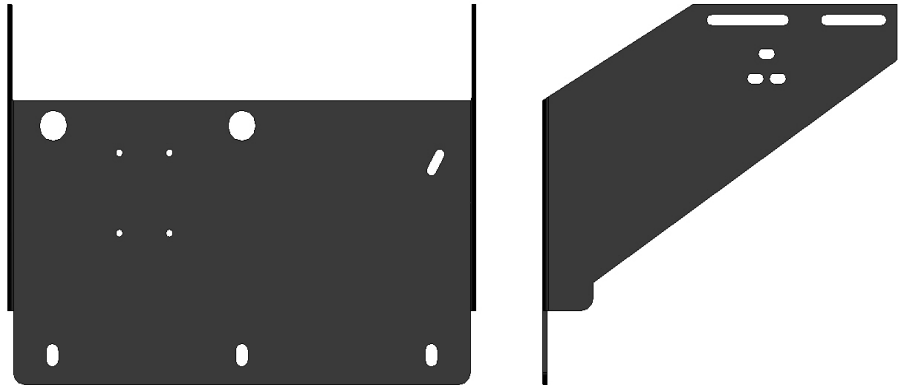

Parts Breakdown for Pump Manifold

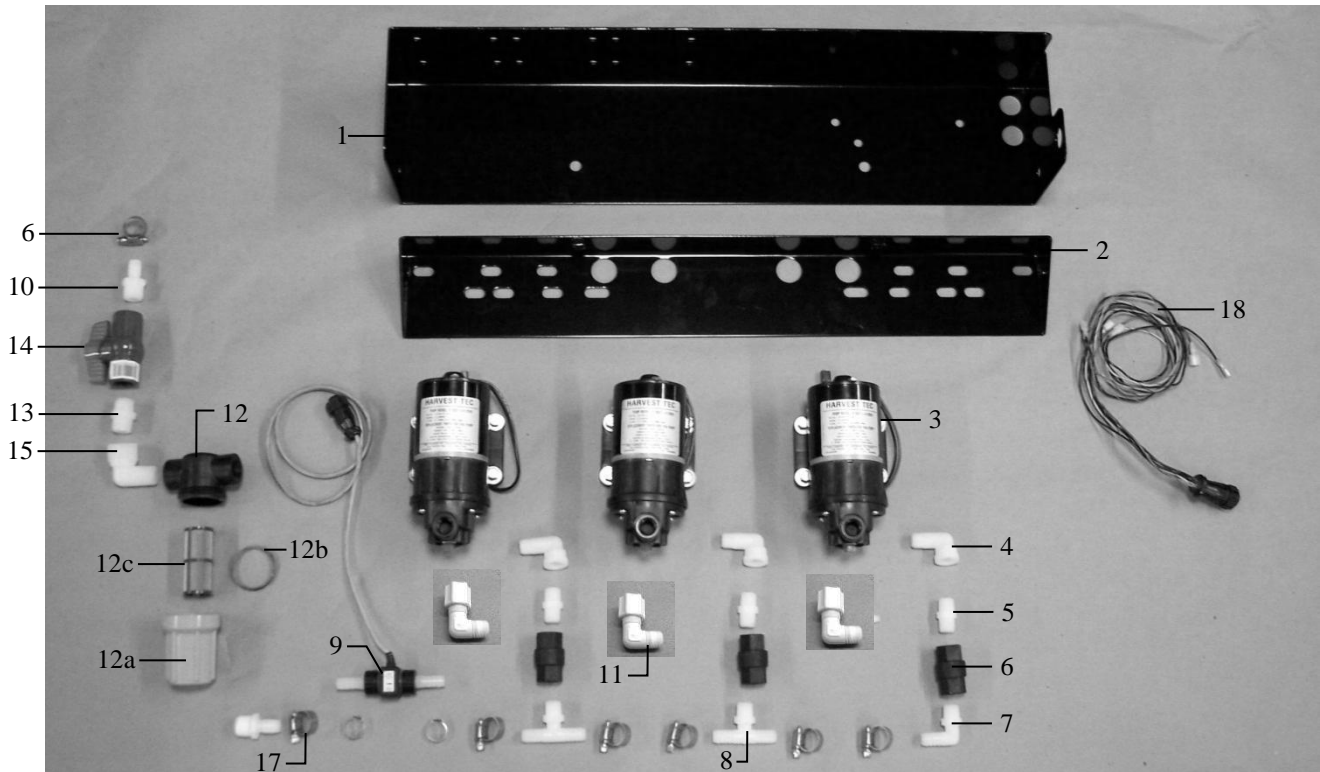

<u>Ref#</u>	<u>Description</u>	<u>Part#</u>	<u>Qty</u>
1	Pump plate	001-4646D	1
2	Mounting Bracket	001-4646C	1
3	Pump	007-4120H	3
4	Street elbow fitting	003-SE38	3
5	Nipple fitting	003-M3838	3
6	Check valve	002-4566F	3
7	Elbow fitting	003-EL3812	1
8	Tee fitting	003-T3812HB	2
9	Flow meter assembly	006-4725A	1
10	Straight fitting	003-A1212	2
11	Jaco fitting	003-JEL1238	3
12	Filter bowl assembly	002-4315-100	1
12a	Filter bowl only	002-4315F	1
12b	Filter bowl gasket	002-4315D	1
12c	Filter bowl screen	002-4315A	1
13	Nipple fitting	003-M1212	1
14	Ball valve	002-2212	1
15	Street elbow fitting	003-SE12	1
16	Hose clamp	003-9003	7
17	Hose clamp (Flow Meter)	003-9005	2
18	Pump Cable	006-4660Z	1
NP	Elbow	003-EL1212	1
NP	Pump rebuild kit (1 per pump)	007-4581	1
	Complete Pump Assembly	030-4646	

Parts Breakdown for Star Wheel Moisture Sensors

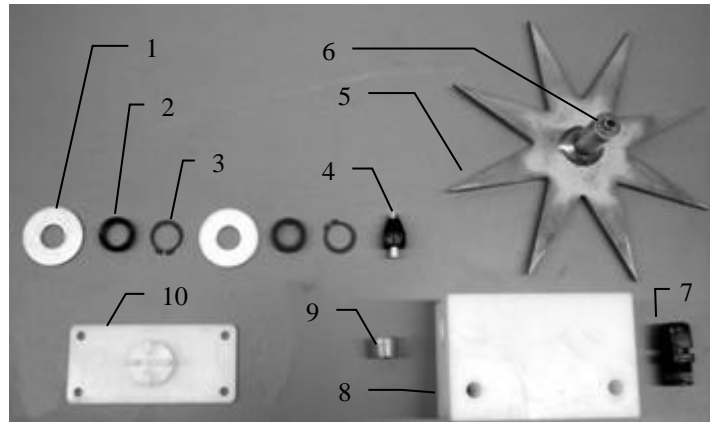

<u>Ref</u>	<u>Description</u>	<u>Part#</u>	<u>Qty</u>	<u>Ref</u>	<u>Description</u>	<u>Part#</u>	<u>Qty</u>
1	Washer (per side)	006-4642K	2	8	Star wheel block	006-4641D	2
2	Dust seal (per side)	w/006-4642K	1	9	Plug fitting	003-F38	2
3	Snap ring (per side)	w/006-4642K	2	10	Block Cover	006-4641B	2
4	Swivel	006-4642A	2	1-10	Star wheel assembly	030-4642	2
5	Star wheel	030-4641E	2	NP	Twine guard – right (prox)	001-4644H	1
6	Insert	w/ Ref # 5	2	NP	Twine guard – left	001-4645H	1
7	Wiring grommet	008-0821A	2				

Bale Rate Sensors

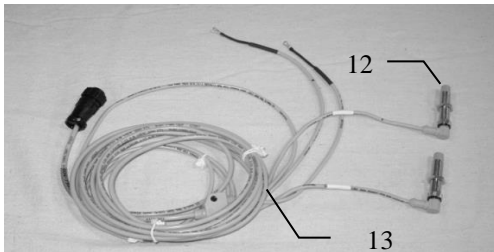

<u>Ref</u>	<u>Description</u>	<u>Part#</u>	<u>Qty</u>
12	Bale rate sensor	006-7303S	2
13	Moisture and bale rate harness	006-7303H	1

Complete Assembly 006-7202

Parts Breakdown for Hose and Drain Fill Line

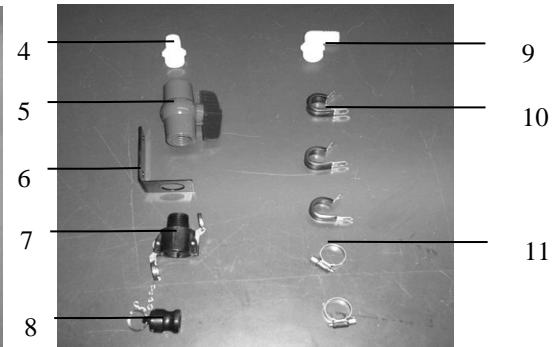
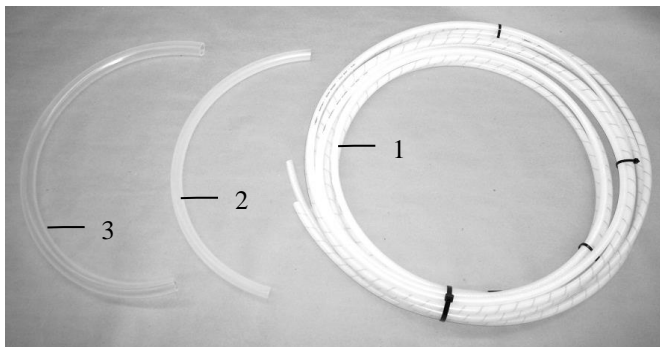

<u>Ref</u>	<u>Description</u>	<u>Part#</u>	<u>Qty</u>	<u>Ref</u>	<u>Description</u>	<u>Part#</u>	<u>Qty</u>
1	Triple weld hose (pumps to tips)	002-9016	35ft	6	Valve Holder	001-6702H	1
		002-9016B	35ft	7	Female Coupler	002-2204A	1
		002-9016G	35ft	8	Male Coupler	002-2205G	1
	Three hose assembly	030-9016LS	1	9	Elbow	003-EL3434	1
2	1/2" Hose (tank to filter)	002-9001	6ft	10	Jiffy Clip	008-9010	3
3	3/4" Hose (tank to drain/fill)	002-9002	10ft	11	Hose Clamps	003-9004	2
4	Straight Fitting	003-A3434	1				
5	Ball valve	002-2200	1				

696J Control and Harnesses



<u>Ref</u>	<u>Description</u>	<u>Part Number</u>	<u>Qty</u>
1	Pump Controller	006-5672	1
2	End of Bale Sensor	006-7400	1
3	DCP Shield Cover	001-5650X	1
4	DCP Main Control LS 600 AUTO	006-6671LS	1
5	Terminating Connector w Green Cap	006-5650Z	1
6	DCP Baler Harness 30 Ft	006-6650LS2	1
7	Modular Power/Comm 10 Ft Harness	006-5650FM	1
8	DCP Tractor Harness	006-6650TM	1
9	Key Switch Wire	006-5650K	1
10	Dust Plugs	006-5651PLUGS	1
11	iPad Integration Control	030-6672C	1
NP	EOB Bracket (JD L330, L340)	001-4648J	1
NP	Baler Integration Harness	006-6650VAJ	1
NP	USB Cable	006-6672USBC	1

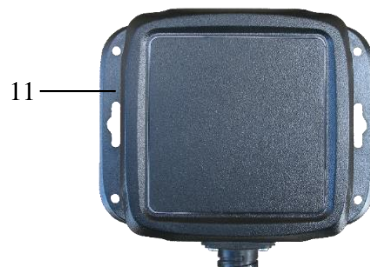

4525JB Installation Kit

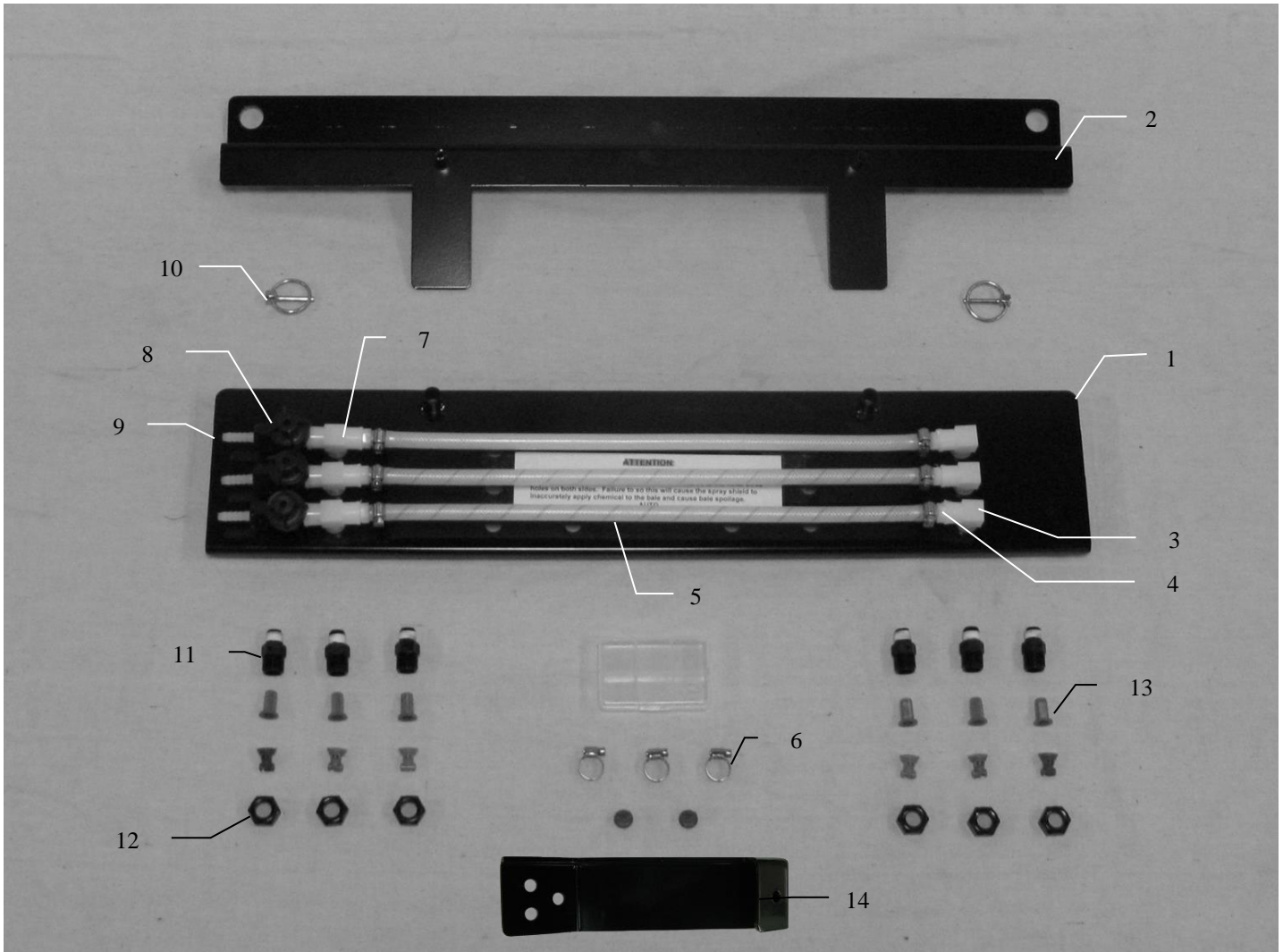

<u>Ref</u>	<u>Description</u>	<u>Part #</u>	<u>Qty</u>	<u>Description</u>	<u>Part #</u>	<u>Qty</u>
1	Spray shield	001-4435ES	1	Tip (olive green)	004-800067-PT	2
2	Shield holder	001-4435EJ	1	Tip (orange)	004-TT11001VP	2
3	Elbow	003-SE14F	3	Tip (green)	004-TT110015VP	2
4	Straight fitting	003-A1414	6	Tip (blue)	004-TT11003VP	2
5	Hose	002-9016	6ft			
6	Hose clamp	003-9002	9			
7	Tee	003-TT14SQ	3			
8	Check valve	004-1207VB	3			
9	Straight fitting	003-A1414VB	3			
10	Lynch pin	008-4576	2			
11	Nozzle body	004-4722	6			
12	Nozzle cap	004-4723	9			
13	Tip strainer	004-1203-100	6			
14	Pump Plate Holder (Not Included w/ Install Kit)	001-6707JX	2			

Optional iPad Mini Mounting Kit (030-2014MK)

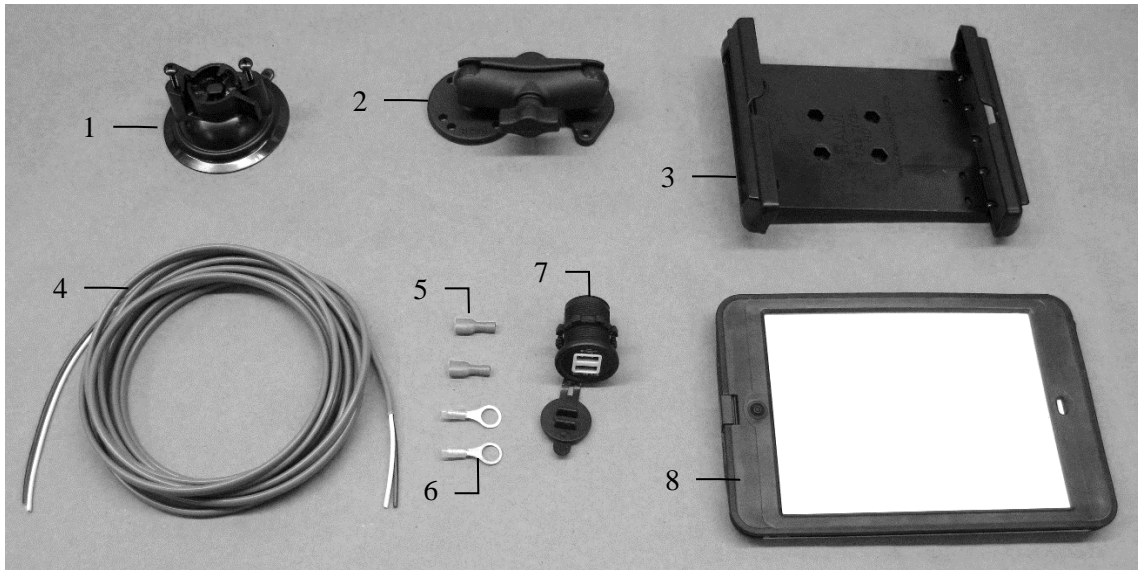

<u>Ref</u>	<u>Description</u>	<u>Part #</u>	<u>Qty</u>
1	Suction cup mount	001-2012SCM	1
2	Ram mount	001-2012H	1
3	iPad Mini® spring load cradle (Mini 4)	001-2012SLC	1
4	16 gauge power wire	006-4723P	1
5	Female spade connector	Hardware	2
6	Eye loop connector	Hardware	2
7	iPad Mini Charger 12V	001-2012P	1
8	iPad Mini 4 case	001-2012C4	1
NP	4 amp fuse	Hardware	1

Mounting Kit Assembly

030-2014MK
(Includes All Parts)

Installation Instructions

1. Identify 12V power source for wires to connect.
 - a. Eye loops included if wiring directly to the battery is desired.
 - b. Test for key power source if preferred to have power to the USB shut off with the key.
2. Once power source is identified, cut wires to desired length.
3. Crimp the two supplied quick connectors onto each the white and black wire.
4. Remove the round locking plastic nut from USB plug before connecting the wires. Black (+) White (-).
5. The wires will then be hooked to the designated terminals on the bottom of the USB plug
6. Drill a 1 1/8" hole in the preferred mounting location. Be sure to clean any sharp edges after drilling.
7. Feed the wires through the mounting hole.
8. If using the round plastic nut to secure plug in place, slide the nut back over the wiring before connecting the wires to powered source.
9. Connect the wires to the identified power source if easier to do so before tightening the plug into place.
10. Tighten plug using either the round plastic nut or mounting plate and two screws, both options supplied.
11. Once connected, hook a USB charging cord into the plug and connect a mobile device/tablet to ensure the plug is operating as you wish (key power working properly if necessary).

NOTE: This plug is not designed to charge two iPads. System damage could occur if this is attempted.
System will charge a mobile phone and iPad simultaneously without problem.

*iPad mini is a trademark of Apple Inc., registered in the U.S. and other countries.

Optional iPad Display Kit (030-4670DK)

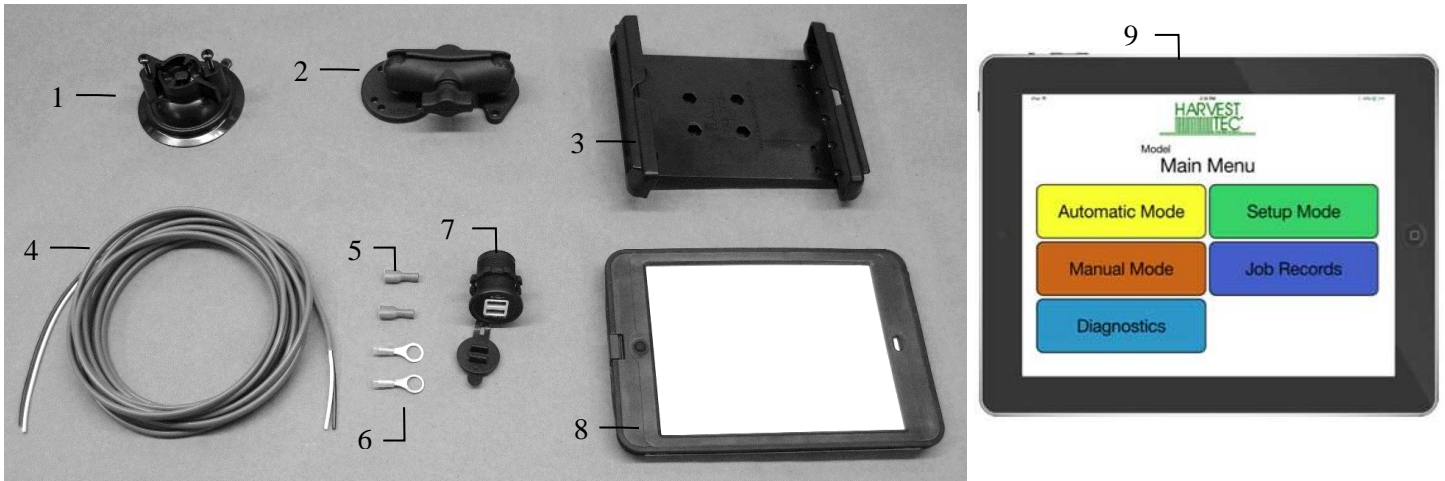

<u>Ref</u>	<u>Description</u>	<u>Part #</u>	<u>Qty</u>	<u>Ref</u>	<u>Description</u>	<u>Part #</u>	<u>Qty</u>
1	Suction cup mount	001-2012SCM	1	7	iPad Mini Charger 12V	001-2012P	1
2	Ram mount	001-2012H	1	8	iPad Mini 4 case	001-2012C4	1
3	iPad Mini® spring load cradle (Mini 4)	001-2012SLC	1	9	iPad Mini 4	006-4670IP	1
4	16 gauge power wire	006-4723P	1	NP	4 amp fuse	Hardware	1
5	Female spade connector	Hardware	2				
6	Eye loop connector	Hardware	2				
					Mounting Kit Assembly	030-4670DK (Includes All Parts)	

Installation Instructions

1. Identify 12V power source for wires to connect.
 - a. Eye loops included if wiring directly to the battery is desired.
 - b. Test for key power source if preferred to have power to the USB shut off with the key.
2. Once power source is identified, cut wires to desired length.
3. Crimp the two supplied quick connectors onto the white and black wire.
4. Remove the round locking plastic nut from USB plug before connecting the wires. Black (+) White (-).
5. The wires will then be hooked to the designated terminals on the bottom of the USB plug
6. Drill a 1 1/8" hole in the preferred mounting location. Be sure to clean any sharp edges after drilling.
7. Feed the wires through the mounting hole.
8. If using the round plastic nut to secure plug in place, slide the nut back over the wiring before connecting the wires to powered source.
9. Connect the wires to the identified power source if easier to do so before tightening the plug into place.
10. Tighten plug using either the round plastic nut or mounting plate and two screws, both options supplied.
11. Once connected, hook a USB charging cord into the plug and connect a mobile device/tablet to ensure the plug is operating as you wish (key power working properly if necessary).

NOTE: This plug is not designed to charge two iPads. System damage could occur if this is attempted. System will charge a mobile phone and iPad simultaneously without problem.

*iPad mini is a trademark of Apple Inc., registered in the U.S. and other countries.

Notes

Harvest Tec Inc. Warranty and Liability Agreement

Harvest Tec, Inc. will repair or replace components that are found to be defective within 12 months from the date of manufacture. Under no circumstances does this warranty cover any components which in the opinion of Harvest Tec, Inc. have been subjected to negligent use, misuse, alteration, accident, or if repairs have been made with parts other than those manufactured and obtainable from Harvest Tec, Inc.

Our obligation under this warranty is limited to repairing or replacing free of charge to the original purchaser any part that in our judgment shows evidence of defective or improper workmanship, provided the part is returned to Harvest Tec, Inc. within 30 days of the failure. If it is determined that a non-Harvest Tec branded hay preservative has been used inside the Harvest Tec applicator system where the failure occurred, then Harvest Tec reserves the right to deny the warranty request at their discretion. Parts must be returned through the selling dealer and distributor, transportation charges prepaid.

This warranty shall not be interpreted to render Harvest Tec, Inc. liable for injury or damages of any kind, direct, consequential, or contingent, to persons or property. Furthermore, this warranty does not extend to loss of crop, losses caused by delays or any expense prospective profits or for any other reason. Harvest Tec, Inc. shall not be liable for any recovery greater in amount than the cost or repair of defects in workmanship.

There are no warranties, either expressed or implied, of merchantability or fitness for particular purpose intended or fitness for any other reason.

This warranty cannot guarantee that existing conditions beyond the control of Harvest Tec, Inc. will not affect our ability to obtain materials or manufacture necessary replacement parts.

Harvest Tec, Inc. reserves the right to make design changes, improve design, or change specifications, at any time without any contingent obligation to purchasers of machines and parts previously sold.

Revised 4/17

HARVEST TEC, INC.
P.O. BOX 63
2821 HARVEY STREET
HUDSON, WI 54016
PHONE: 715-386-9100
1-800-635-7468
FAX: 715-381-1792