

Operation Manual

Model 695BBHD

***115 Gallon Preservative Applicator
New Holland & Case IH BB High Density Baler***



P.O. Box 63 • 2821 Harvey Street • Hudson, WI 54016
800-635-7468 • www.harvesttec.com

DECLARATION OF INCORPORATION



MANUFACTURER:

Harvest Tec Inc.
2821 Harvey St.
P.O. Box 63
Hudson, WI 54016, U.S.A.

REPRESENTATIVE ESTABLISHED IN COMMUNITY: Profitable Farming Company
Middle Barlington, Roborough
Winkleigh, Devon, EX19 8AG
ENGLAND

The person above certifies and declares that:

VIRTUAL MACHINE: Equipment mounted on a farm press and for the application of inoculants onto forage crops.

MODEL: 695BBHD-20-OPR (Imp&Metric)

BRAND: Harvest Tec

SERIAL NUMBER:

This application preservatives for hay Harvest Tec system meets the Directive 2006/42/EC of the European Parliament and the Council of 17 May 2006 and other applicable European Directives including Directive 2004/108/EC on the Electromagnetic compatability.

The application of preservatives for hay Harvest Tec system will be turned on after being installed on a farm press has been declared in conformity with the Machinery Directive.

Person in the community authorized to provide information on the partly completed machinery and making this statement:

Richard Snell, President, Profitable Farming Company

Signed on May 21, 2011: Middle Barlington, Roborough
Winkleigh, Devon, EX19 8AG
ENGLAND

Harvest Tec 695BBHD Operation Manual Table of Contents

	<u>Page</u>
Introduction	4
System Requirements	4
Safety	4
Safety Decals	5
Preparing the Applicator for Operation	6-7
Filling the Tank	6
Connecting Power and Communication Harnesses	7
Operation of Main Ball Valve	7
Communicating through the ISOBUS Monitor	8-16
Description of Screens and Menus of the Harvest Tec Monitor	17-23
Screen Menus	17
Automatic Mode	18
Manual Mode	19
Diagnostics	20
Setup Mode	21-22
Job Records	23
First Time and Annual Start Up Instructions	24
Checking and Priming the Pumps	24
Setting Up Application Rate and Bale Parameters for Initial Use	25-26
Application Rate Setup	25
Baling Rate Setup	26
Operating Instructions	27-31
Automatic Mode	27
Manual Mode	28
Diagnostics	29
Job Records	30-31
iPad Integration Control Module	32
iPad Integration Control Light Signals	32
Bluetooth Receiver Lights	32
Maintenance	33-35
Maintenance Schedule & Diagnostics	33
Filter Bowl Cleaning	33
Tips and Tip Screen Cleaning	34
Tank Lid Cleaning	35
Dielectric Grease Connections	35
Rebuild Pumps, Battery Connections, Check Valves	35
Winter Storage	36
Tip Selection Guide	36
Wiring Diagram	37
Pin Outs for Harnesses and Wiring Diagram	38-40
Common Questions	41
Troubleshooting	42-43
Parts Breakdown	44-53
Tank and Saddle Legs	44
Pump Manifold	45
Star Wheel Moisture Sensor and Baler Rate Sensors	46
Hose and Drain Fill Line	47
Controls and Harnesses-Dual Channel Processor (DCP)	48
4636B Install Kit	49
Rear Light / Camera Bracket	50
Optional iPad Mini Mounting Kit	51
Optional iPad Display Kit	52
Notes	54
Warranty Statement	55

Introduction

Thank you for purchasing the 695BBHD Hay Preservative Applicator System. This applicator system has been designed to plug directly into the baler's ISOBUS and display on the New Holland Intelliview 3 or Intelliview 4, Case Pro 300 or Pro 700. As well as the option of operation through an Apple iPad (not included) using the Hay App. The Preservative Applicator System offers these advantages:

1. Operation coordinated with baler operation
2. Less cab clutter providing better visibility
3. Ease of use with all information on one screen
4. Records kept together
5. The system is ready for future updates

The 695BBHD Hay Preservative Applicator System is designed to apply buffered propionic acid to the forage crop as it is baled. The 695BBHD Applicator will adjust the rate of application based on moisture and tonnage of the crop being harvested. This manual will take you through the steps of operation. Please read this manual carefully to learn how to run the equipment correctly. Failure to do this can result in personal injury or equipment malfunction. If you are unsure about installing the system after consulting this manual, contact your local authorized dealership for additional assistance or look for the contact information on the back cover of this manual. This applicator is designed to apply Crop Saver and Thirty Plus buffered propionic acid.

Right and Left sides are determined by facing in the direction of forward travel.

***Made for iPad® (3rd through Pro 2nd generation), running the current iOS operating system or one version previous required for iPad option**

*iPad is a trademark of Apple Inc., registered in the U.S. and other countries.

****600 Series Applicators with serial number before DCP27000 will require the DCP to be sent to Harvest Tec for a required update in order to use the iPad Integration Module (030-6672C).**

*Hay App version must be **at least 2.7.1 (or higher)** to operate with the iPad Integration Module

System Requirements



**The Baler Control Module (BCM)
must have Version 4.2.0.0 or higher.**



In order for CNH Baler to receive the ThirtyPlus or CropSaver System messages regarding Status, Moisture and preservative, and display this information on the Baler Work Screen, the software in the Baler Control Module (BCM) needs to be updated to version 4.2.0.0 or higher. This software will be available in EST 7.8.0.0 patch 4 (May at dealerships) and EST 8.0.0.0 (June at dealerships). Dealers can log an ASIST incident and request the BCM software from CNH Technical Support Services if they need the software prior to those release dates.

Safety

Carefully read all the safety signs in this manual and on the applicator before use. Keep signs clean and in good working order. Replace missing or damaged safety signs. Replacement signs are available from your local authorized dealer. See your installation manual for under the replacement parts section for the correct part numbers.

Keep your applicator in proper working condition. Unauthorized modifications to the applicator may impair the function and/or safety of the machine.

Carefully read and understand all of the baler safety signs before installing or servicing the baler. Always use the supplied safety equipment on the baler to service the applicator.

Safety Decals

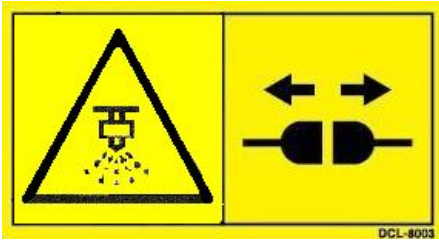

Number 1
Spraying hazard. Disconnect power before servicing the applicator
Part no. DCL-8003



Number 2
Falling hazard. Do not step in this area.
Part no. DCL-8002



Number 3
Use caution when working around chemicals. **Wear all protective equipment according to the label of the product.**
Part no. DCL-8001



Number 4
Read and understand the operator's manual before using or working around the equipment.
Part no. DCL-8000

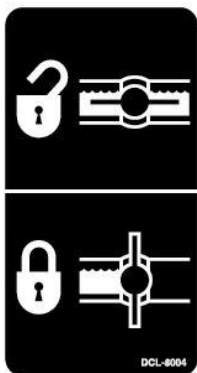

Number 5
Open (unlocked) and closed (locked) position of the ball valve.
Part no. DCL-8004

Preparing the Applicator for Operation

After the applicator has been installed on the baler follow the steps below to prepare for operating the applicator both safely and correctly.

Filling the Tank:

Read the label of the product being filled into the tank to determine what individual protective measures need to be taken. Locate the drain/fill line on the right side of the baler.

Open the cam-couplers (A) and remove the protective plug (B). Insert the male coupler (found on transfer pump) into the female cam and close the cams (A). To open the ball valve (C) turn the handle so it is vertical.

After the ball valve has been turned on switch the pump to the ON position. Monitor the level on the tank visually and shut off the pump before over filling. Once the pump is turned off, close the ball valve and remove the male coupler. The handle of the ball valve (C) will be horizontal when closed. Reinstall the protective plug and close the cams. The Harvest Tec model 9212, 9214, or 9215 transfer pump is recommended for this process.

*Water is recommended for first time and annual start up procedures.



Drain/Fill line on right side of baler

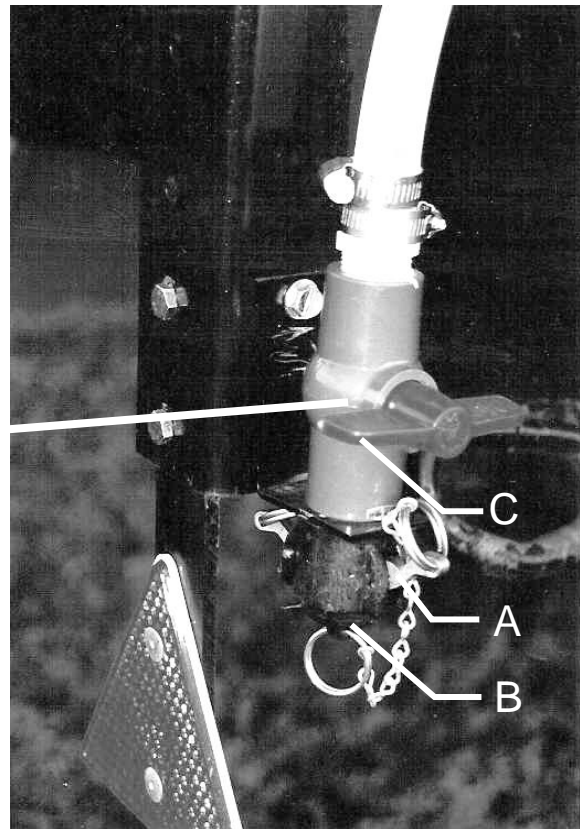

Enlarged view of the drain/fill line valve and cam-coupler assembly.

Connecting Power and Communication Harnesses

The harnesses (006-6650TM & 006-6650LS) are located at the front of the baler near the hitch and at the back of the tractor near the drawbar. See arrow below. Make sure all connection wires are free between the hitch of the baler and the back of the tractor, especially when tractor is turning away.

WARNING: Stop tractor engine and shift to park, set brakes and remove key before leaving the tractor.



Operation of the Main Ball Valve

The ball valve shall be closed at all times when the applicator is not being used. The valve shall also be closed when any service work is being done to the baler or applicator.

The ball valve is located on the left side of the baler, connected to the pumping manifold. See arrow below.

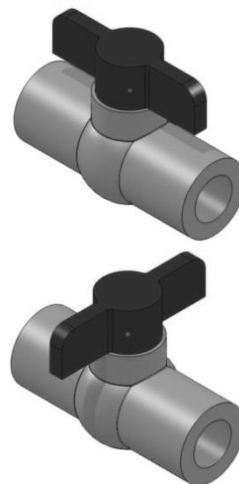
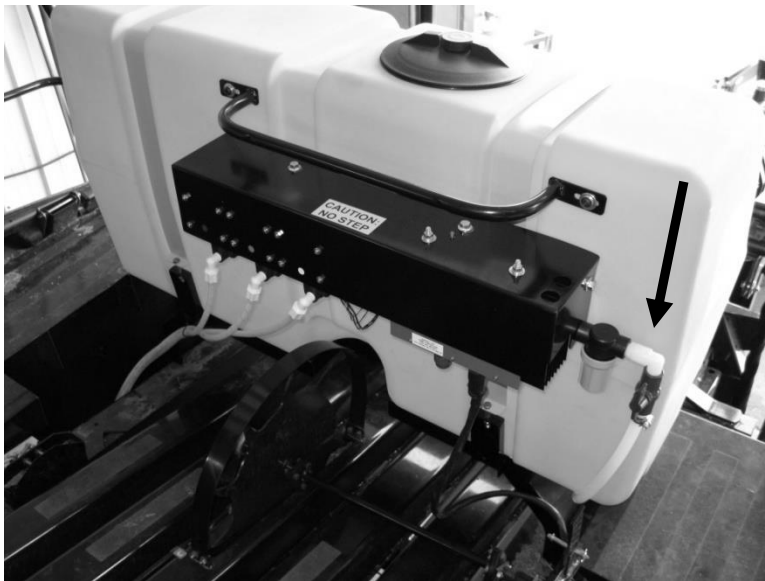

Open valve position

Closed valve position

Communicating through the ISOBUS Monitor to Utilize the Hay Preservative Applicator

When the 600 Series processor is connected to the baler and powered on the first time it is necessary to load the object pools to the Virtual Terminal (VT).



Icon (1) indicates that the object pools are in the process of loading and saving to the VT. Note that if the language selection of the VT is changed, the corresponding object pool must be reloaded to the VT. The object pool loading process takes approximately two minutes to complete.

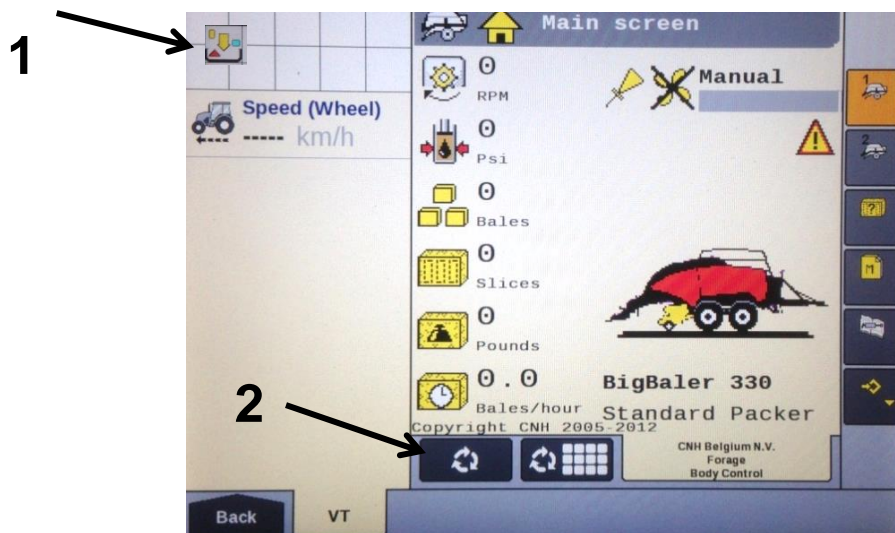

Once the object pools have been loaded and Icon (1) disappears from the upper left corner of the display, press the NEXT IMPLEMENT button (2) and verify that the 600 Series object pools appear on the Virtual Terminal.

After verifying that the 600 Series object pool is loaded and the 600 Series System operating screens are displayed on the VT, press the NEXT IMPLEMENT button (3) to return to the baler work screen page.

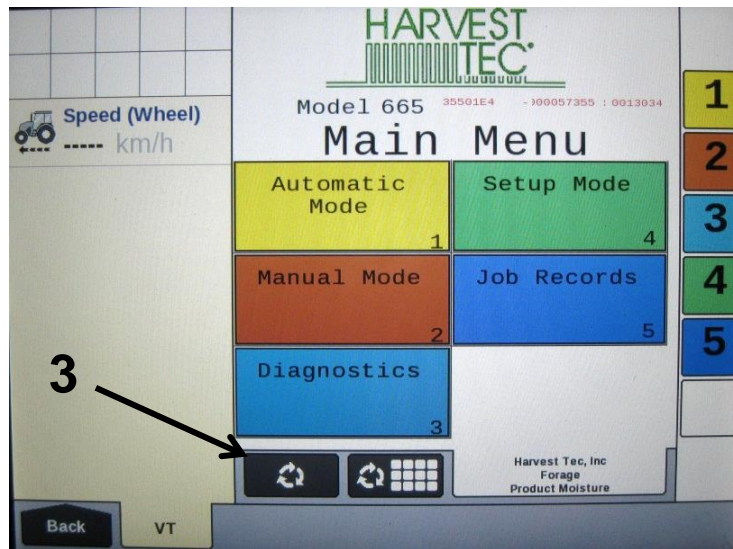

Press the bottom button of the Menu Bar with the down arrow in corner (4) on the side of the screen to continue down the Menu Bar below the USER SETTING icon.

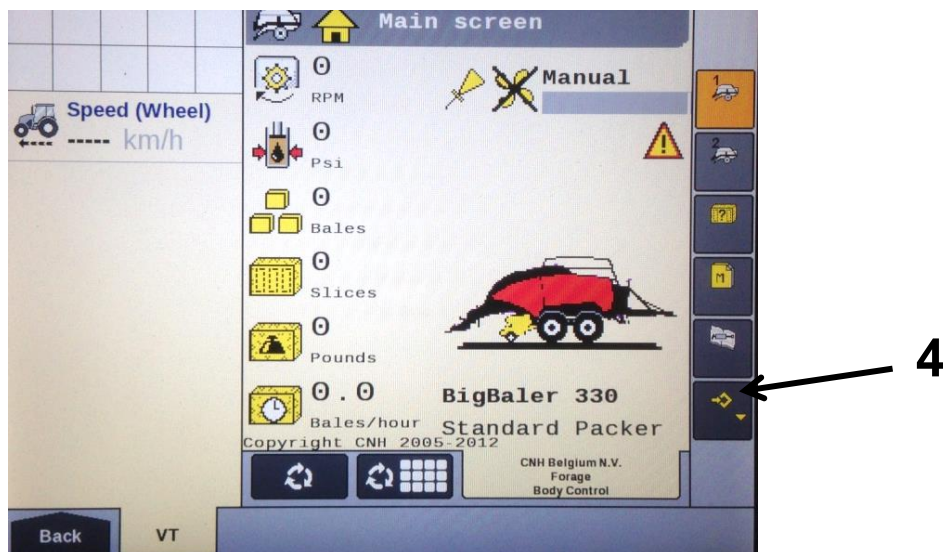

Scroll through the Menu bar until the INFORMATION icon (5) is visible. Press the INFORMATION button so the Information page appears. Verify that the controller software loaded to the baler is version 4.2.0.0 or higher. If not, contact the dealer to update firmware in Baler Control Module (BCM). If the controller software displays version 4.2.0.0 or higher proceed to configuring the baler for the 600 Series System by pressing the MACHINE SETUP button (6).

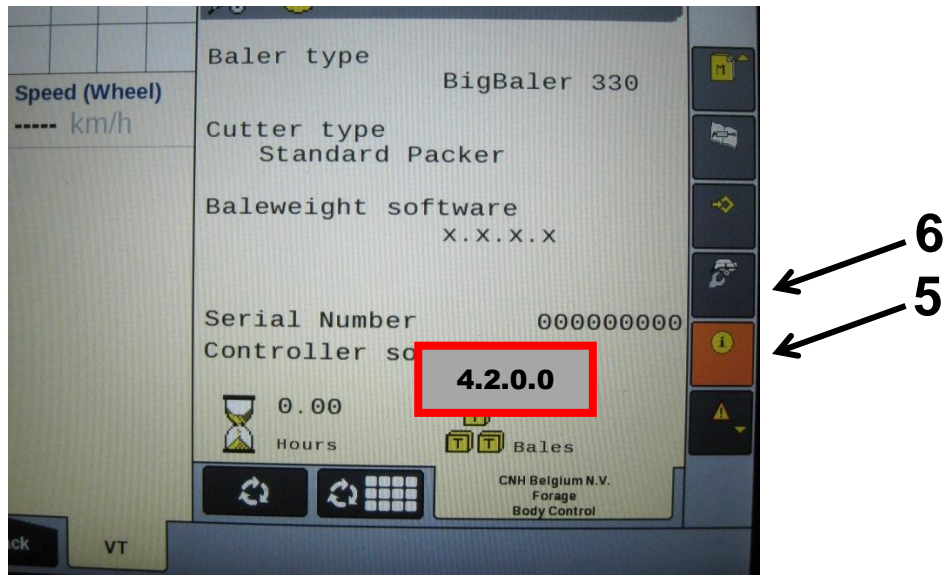

Once the MACHINE SETUP icon has been selected, the Machine Setup page will appear, and the icon will be backlit in orange. Press the MACHINE SETUP icon (7) again to go to the second page of the Machine Setup.

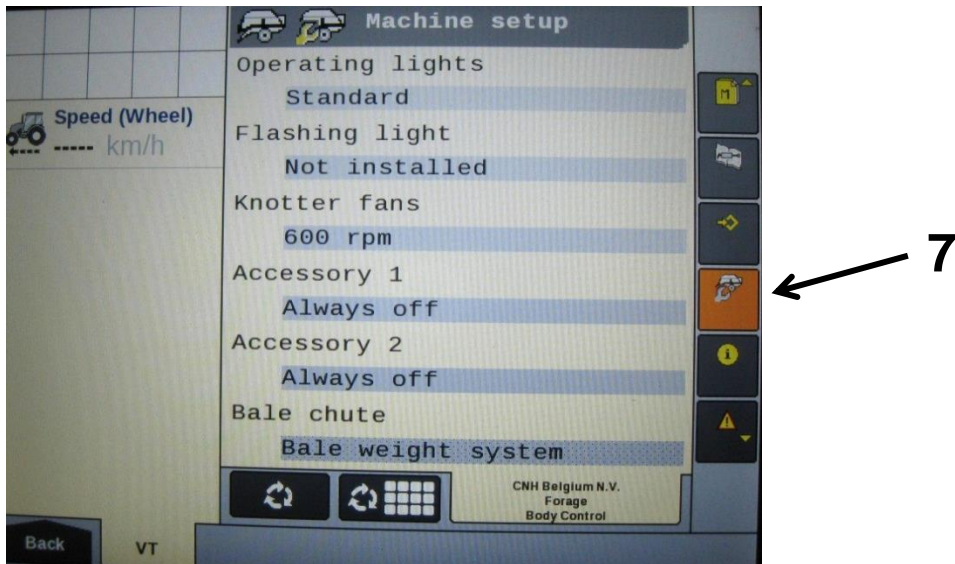

The second page of the Machine setup is identified by the three gray buttons in the Menu Bar. Press and hold the third gray button (8) for 10 seconds or until the display switches to displaying Dealer Mode.

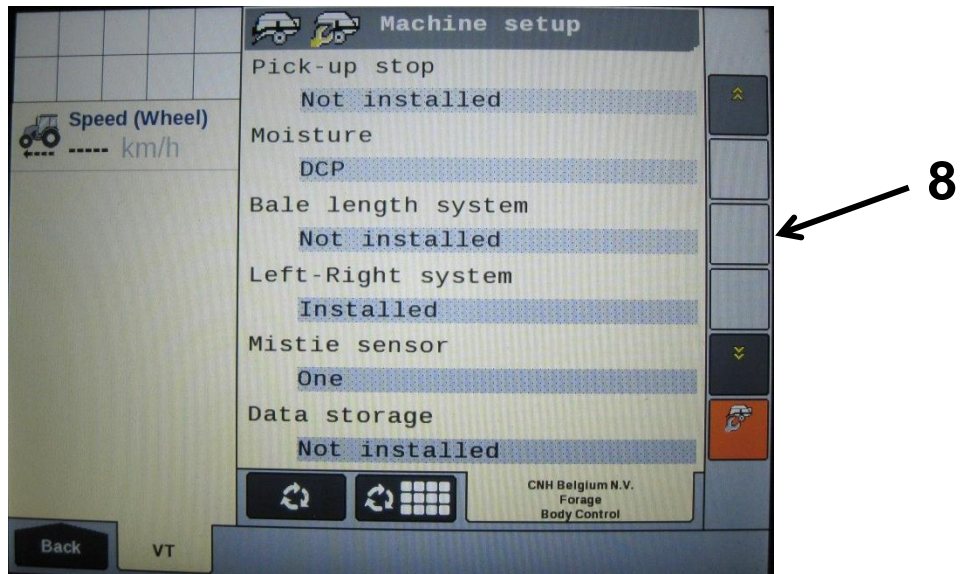

Once Dealer Mode has been entered, select the down arrow in the Menu Bar (9) to scroll to the second Dealer Mode Screen where 'Moisture' is a selection.



Once you have reached the second Dealer Mode screen, select the area under 'Moisture'(10). Note that the box below 'Moisture' will likely be the default "NOT INSTALLED".

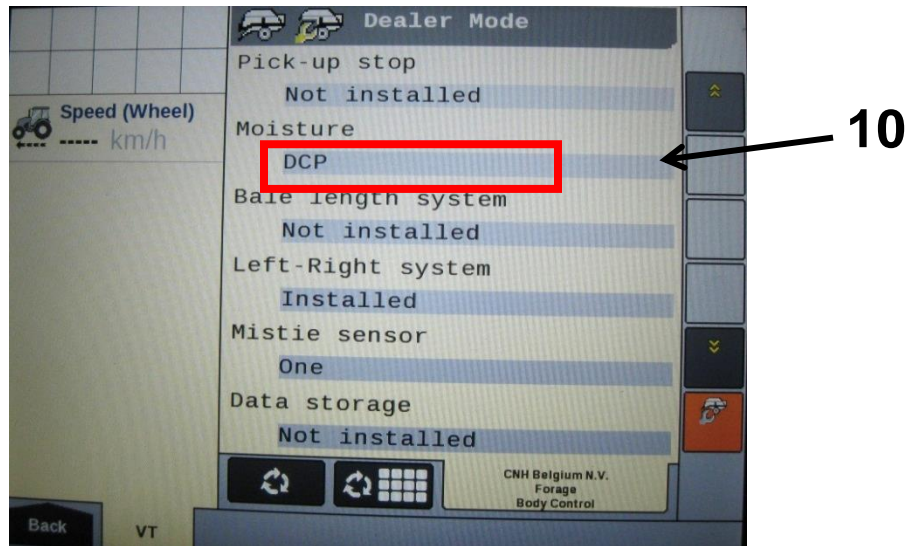

Select the proper configuration setting from the pop up menu (11), based on the configuration of your 600 Series system. This configuration setting allows the baler to properly display the information it is receiving from the 600 Series system on the baler working screen. Select "DCP."

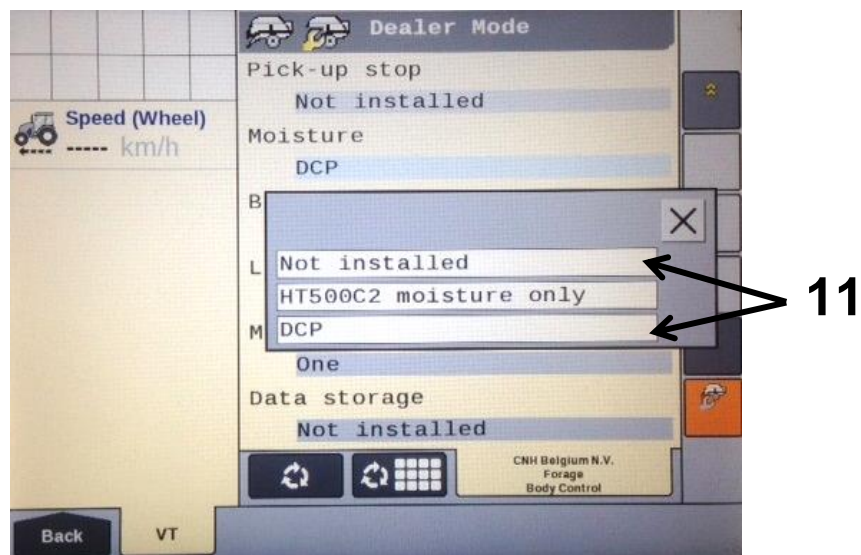

Note: "HT500C2 moisture only" is not ISOBUS compatible and is not an option in North America.

Once the configuration has been set press the MACHINE SETUP icon (12) to return to the Machine Setup Screen and the Menu Bar.

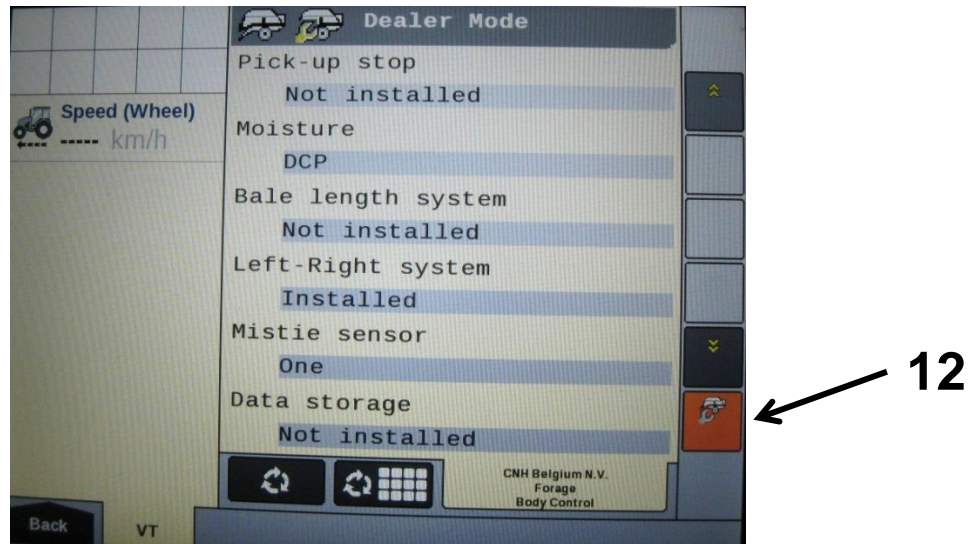

Press the arrow down button at the bottom of the Menu Bar (13) to scroll down thru the Menu Bar until you reach the SCREEN SETUP pages.

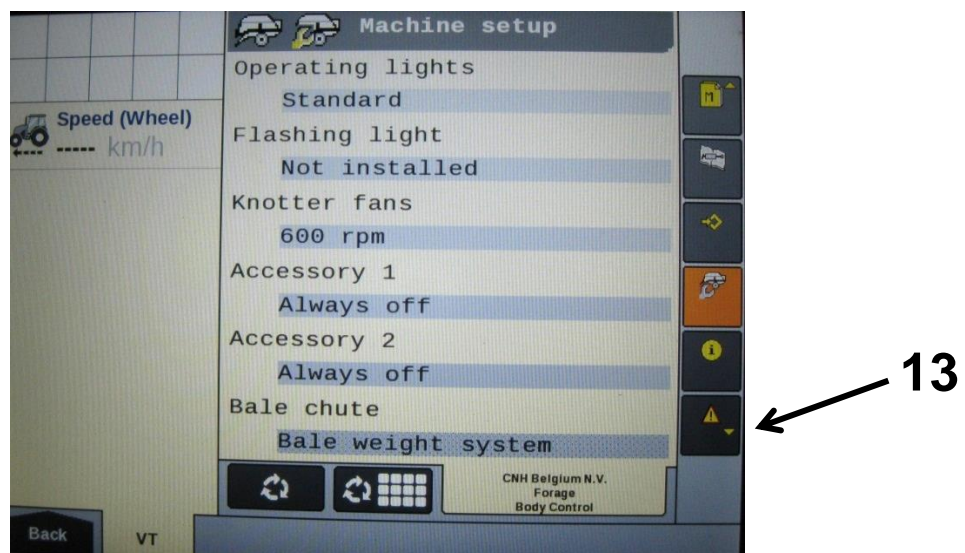

Select the icon for SCREEN SETUP 1 (14) so the Screen Setup 1 screen appears. Select how you would like to have the screen configured to show a combination of baler and 600 Series system information by selecting the boxes. When you select one of the boxes, a popup screen will appear that shows the selections available.

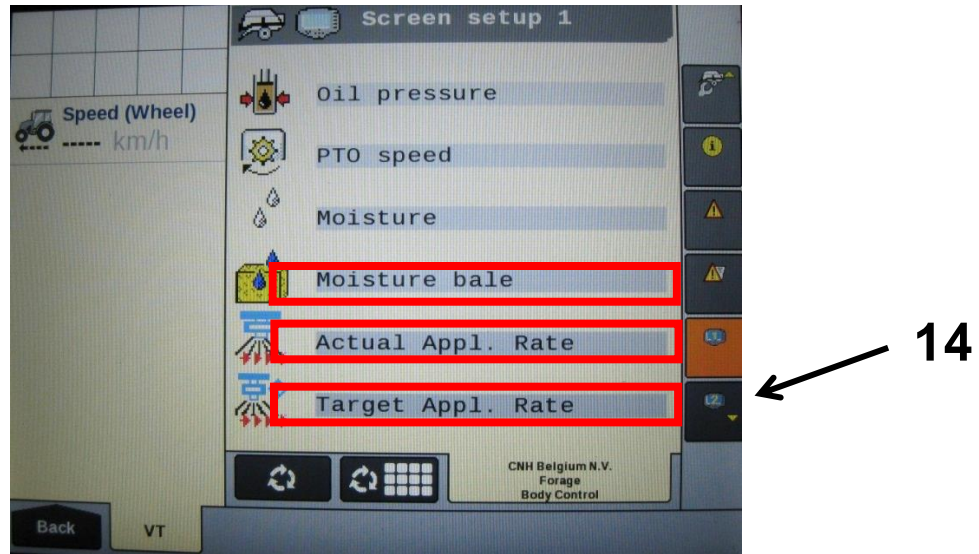

Selections related to the 600 Series system include Moisture, Moisture Bale, Target Application rate, and Actual Application Rate, and are highlighted by arrows above and in the next picture. Scroll to additional options in the popup window by pressing the down arrow on the side of the popup window (15).

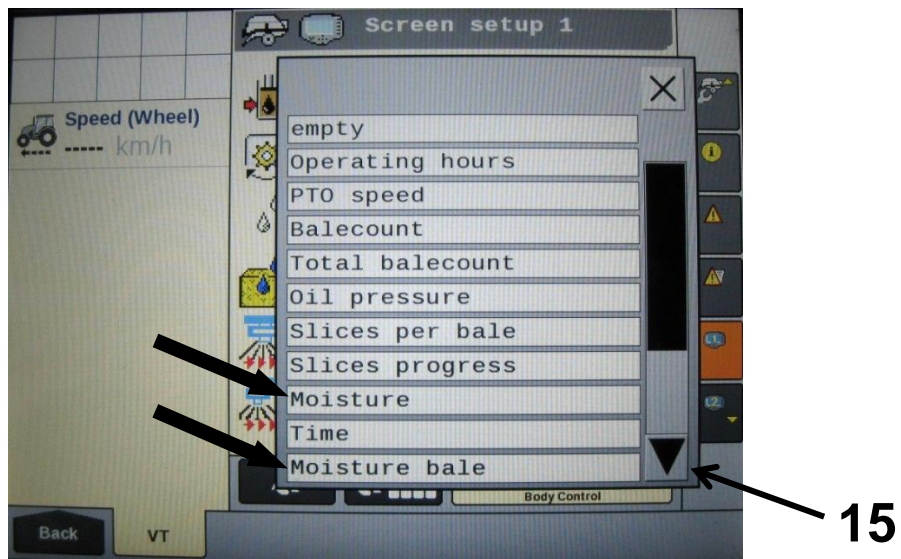

Once the Screen Setup pages have been configured, scroll back up to the top of the Menu Bar by pressing the top button in the Menu Bar with the up arrow (16).



Select the FIELD SETTING icon (17) and adjust the Moisture Alarm Settings in the Field Setting Screen. Note: low moisture alarm must be set lower than the high moisture alarm. The moisture alarms can be turned off by setting the low setting <9% and the high setting >70%. When the alarms are turned off, they will say OFF next to the values. Select the MAIN SCREEN 1 icon (18) from the Menu Bar.

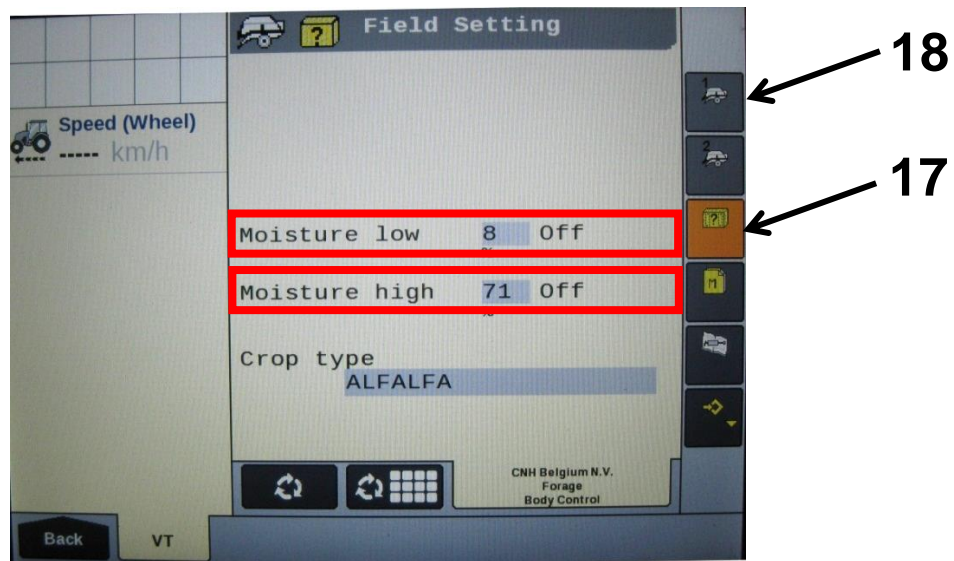

Verify that your MAIN SCREEN 1 and MAIN SCREEN 2 are configured as you would like them displaying the information you would like visible during operation. During operation, information for the 600 Series System that you have chosen to display will be displayed on the Baler Work Screen.

You can cycle back and forth between the Baler Work Screen and the 600 Series System Work Screen by pressing the NEXT IMPLEMENT button (19) during operation.

Harvest Tec Icons signified by arrows 19-25 are as follows:

- (19) Next Implement Button
- (20) Moisture Content %
- (21) Last Bale Average Moisture Content %
- (22) Actual Application Rate of Preservative
- (23) Target Application Rate of Preservative
- (24) DCP Status Icon
- (25) Tagger Status Icon

The DCP Status Icon (24) indicates the DCP is connected to the baler. An “X” over the DCP Status Icon indicates the DCP System is:

- A) Not in an application mode
- B) Paused through
 - a. Manual Pause
 - b. Hay Indicator Pause
 - c. Baler End Of Row (EOR) Pause (PTO speed < 600 rpm)

When the Tagger Status Icon (25) is visible the DCP System is indicating the Tagger is activated. When the DCP System is not in Application Mode or has been paused there will be an “X” over the Tagger Status Icon.

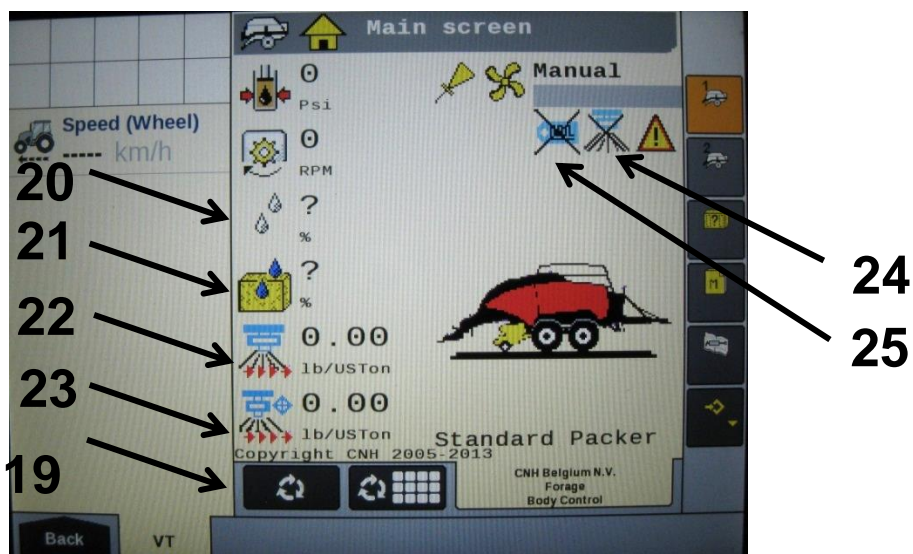

Operations of the ISOBUS Monitor

Description of Screens and Menus of the ISOBUS Monitor

All Buttons are color coded and labeled. Selections can be made by touching the actual screen choice or by touching the numbers down the right side menu which are color and numerically coded to correlate with the same selection.

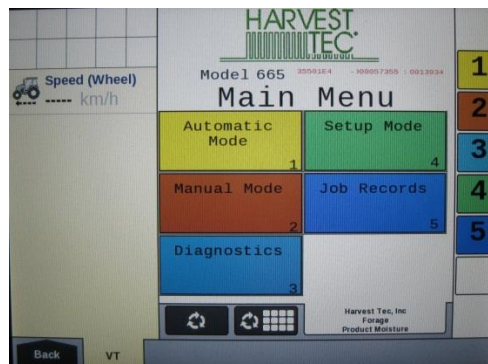

Main Menu of the Preservative Applicator Screen

Listed below are the Main Menu Options.

Automatic Mode (1) This operating mode automatically adjusts preservative application as you bale. The following items are displayed in the mode while baling: Moisture, Baling Rate, Application Rate (actual and target), Last Bale Average Moisture, Tons Baled, and Pounds of Product Used.

Manual Mode (2) This operating mode allows the three different pumps to be turned on at a fixed rate as you bale. The following items are displayed in the mode while baling: Moisture, Baling Rate, Application Rate (actual only), Last Bale Average Moisture, Tons Baled, and Pounds of Product Used. This mode can also be used to prime the pumps.

Diagnostics (3) Allows operator to set the date and time. The installed software versions can also be viewed here.

Setup Mode (4) This mode allows the operator to customize the applicators settings for their baler and baling needs. This mode allows changes to be made to the following areas: Application Rate, Baling Rate, Language, US or Metric units, and turn on/off the optional Hay Indicators.

Job Records (5) Keeps track of up to 300 jobs with total product used, average moisture content, highest moisture content, tons baled, date of baling, and total number of bales made. Individual bales are also able to be viewed and the records can also be downloaded to a USB drive in this mode.

Screen Menus

Use the below listed screen menus to navigate through all of the operation screens. Navigation through the screens is accomplished by using the touch screen of the controller and pressing.

Automatic Mode:

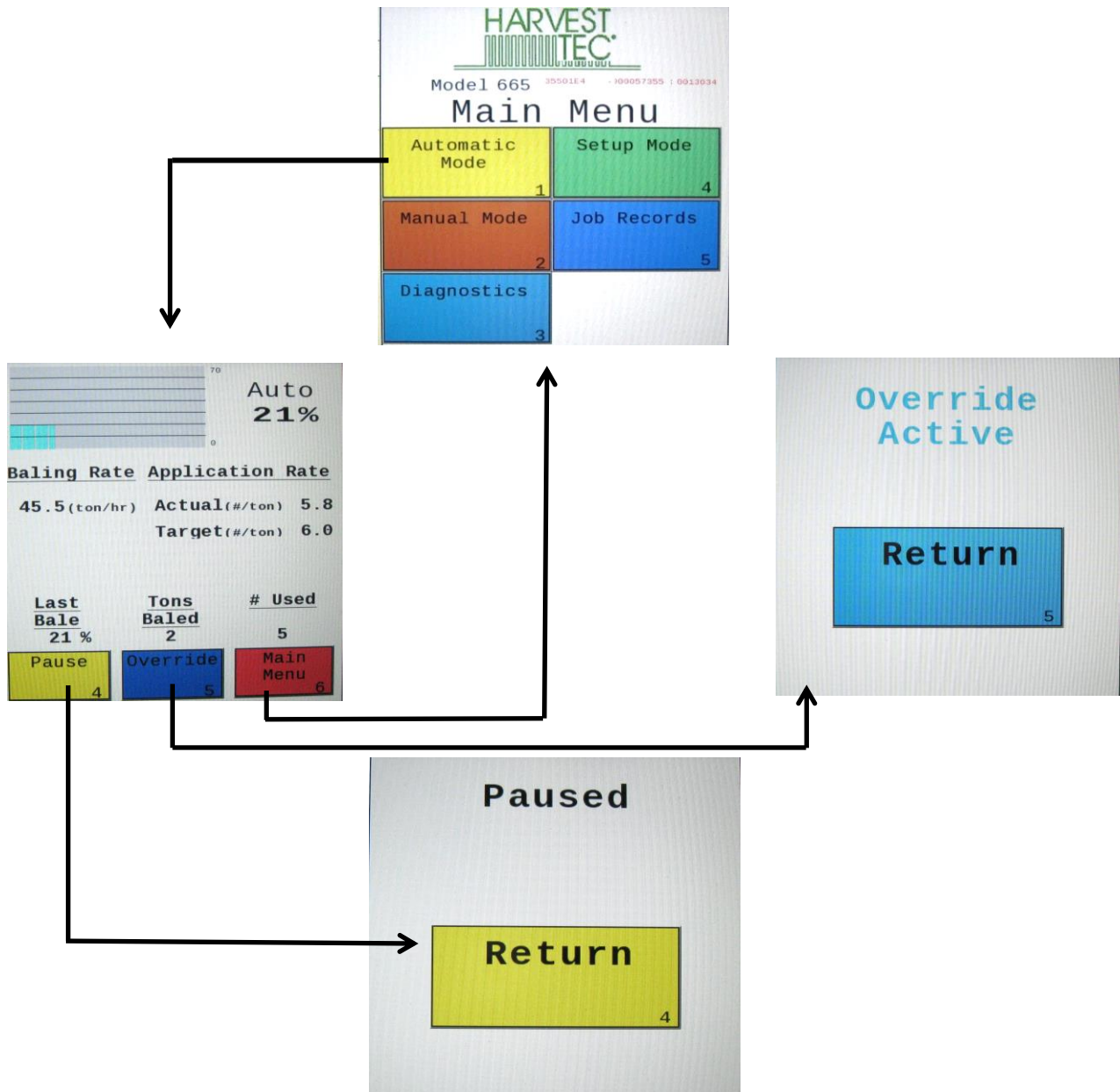

Manual Mode:

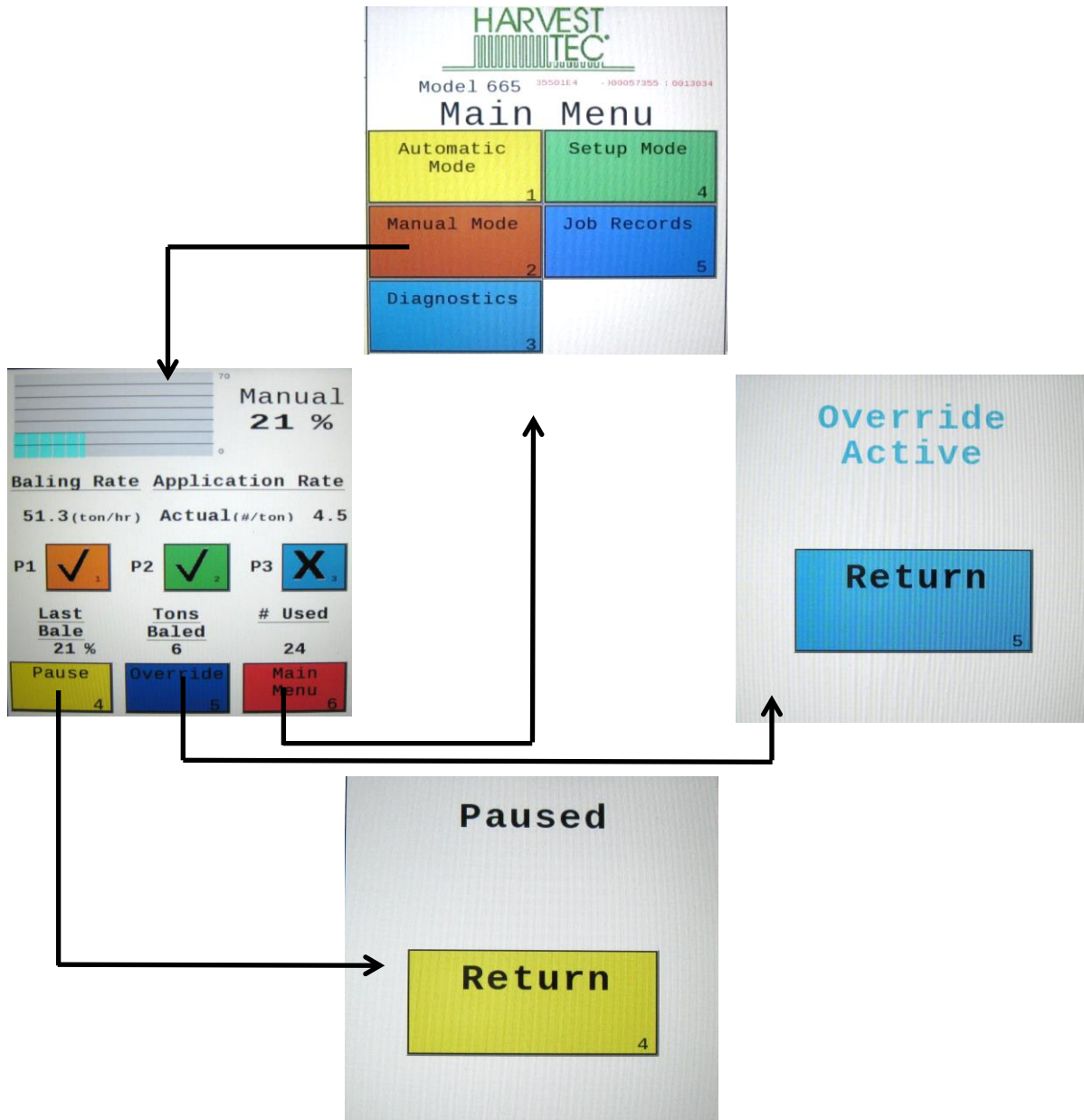

Diagnostics:

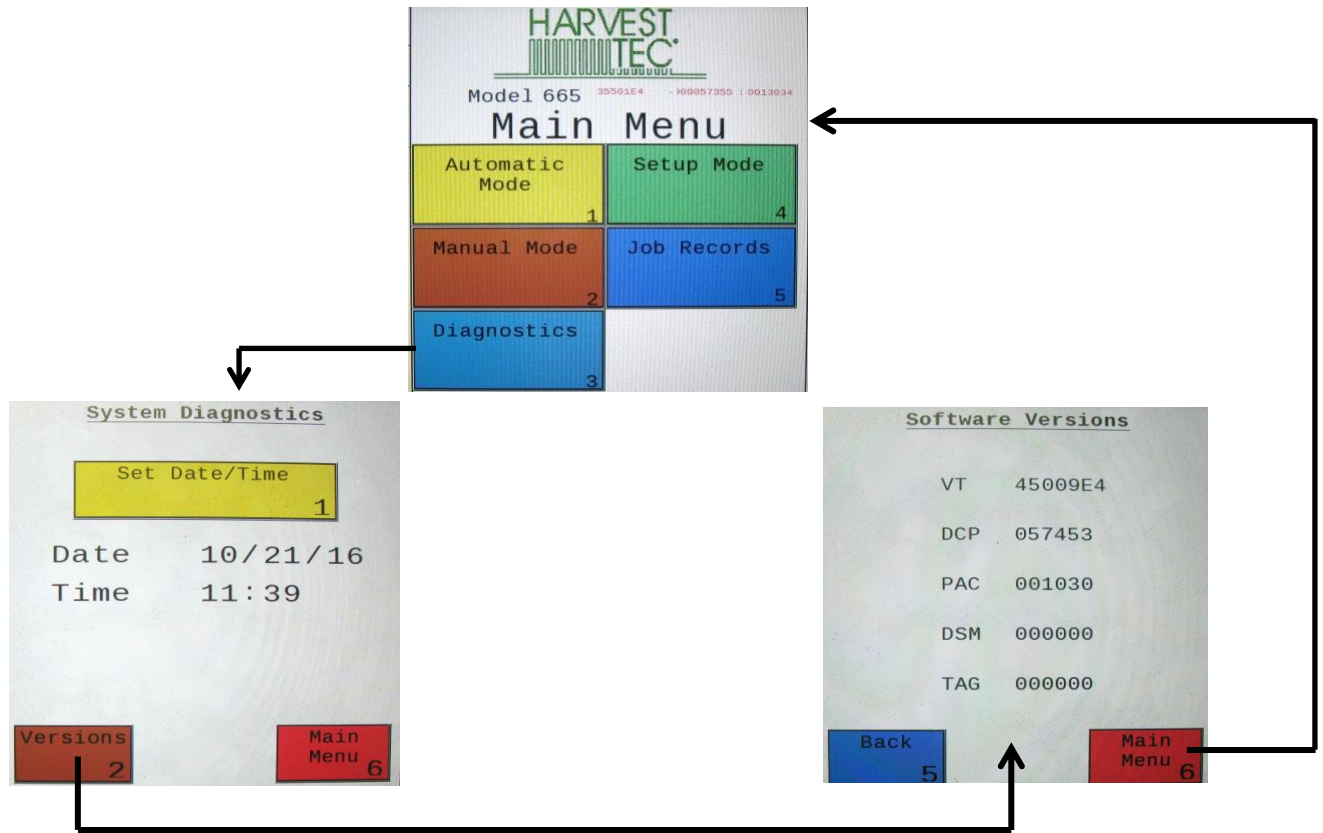

Setup Mode:

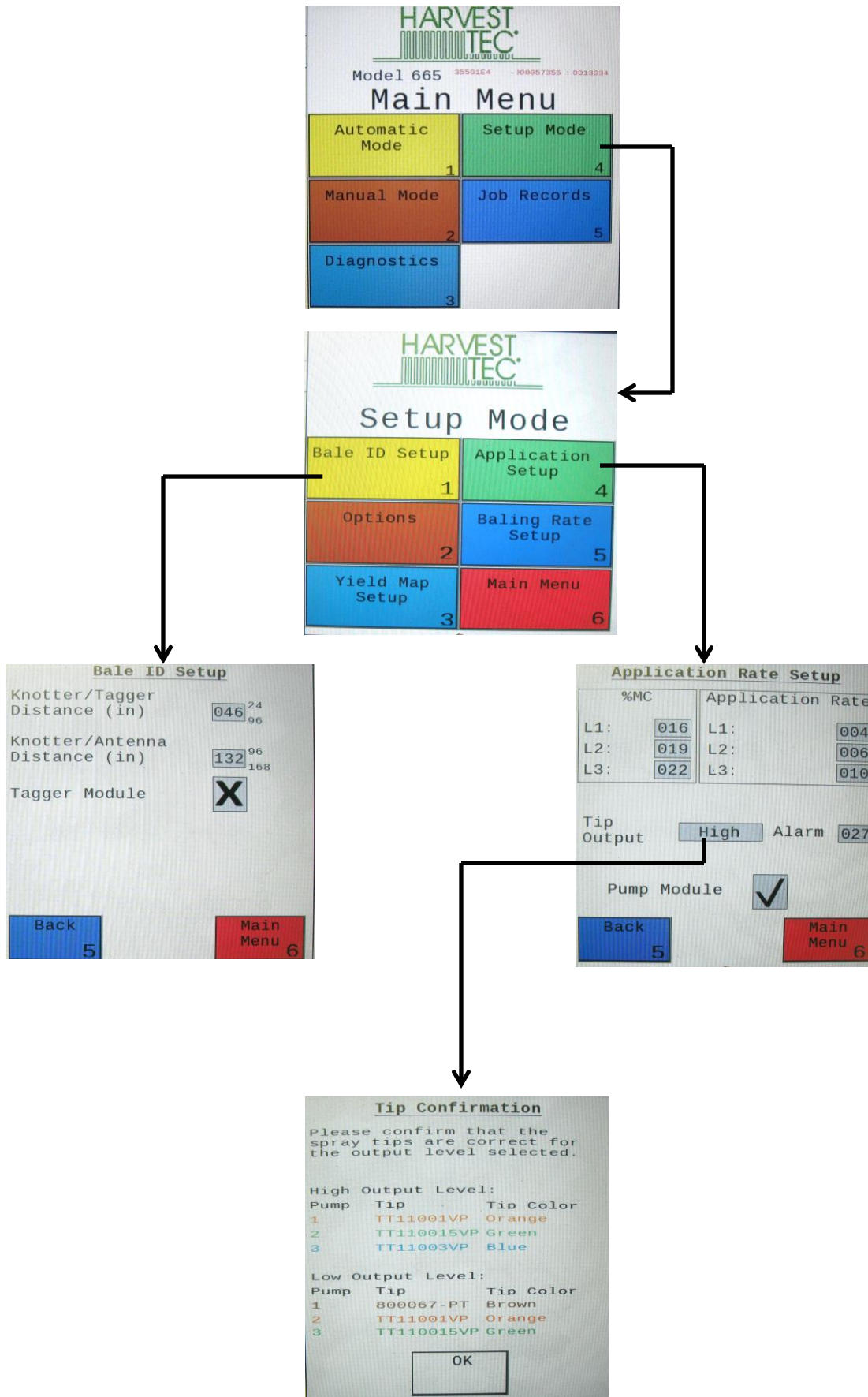

Setup Mode (continued):

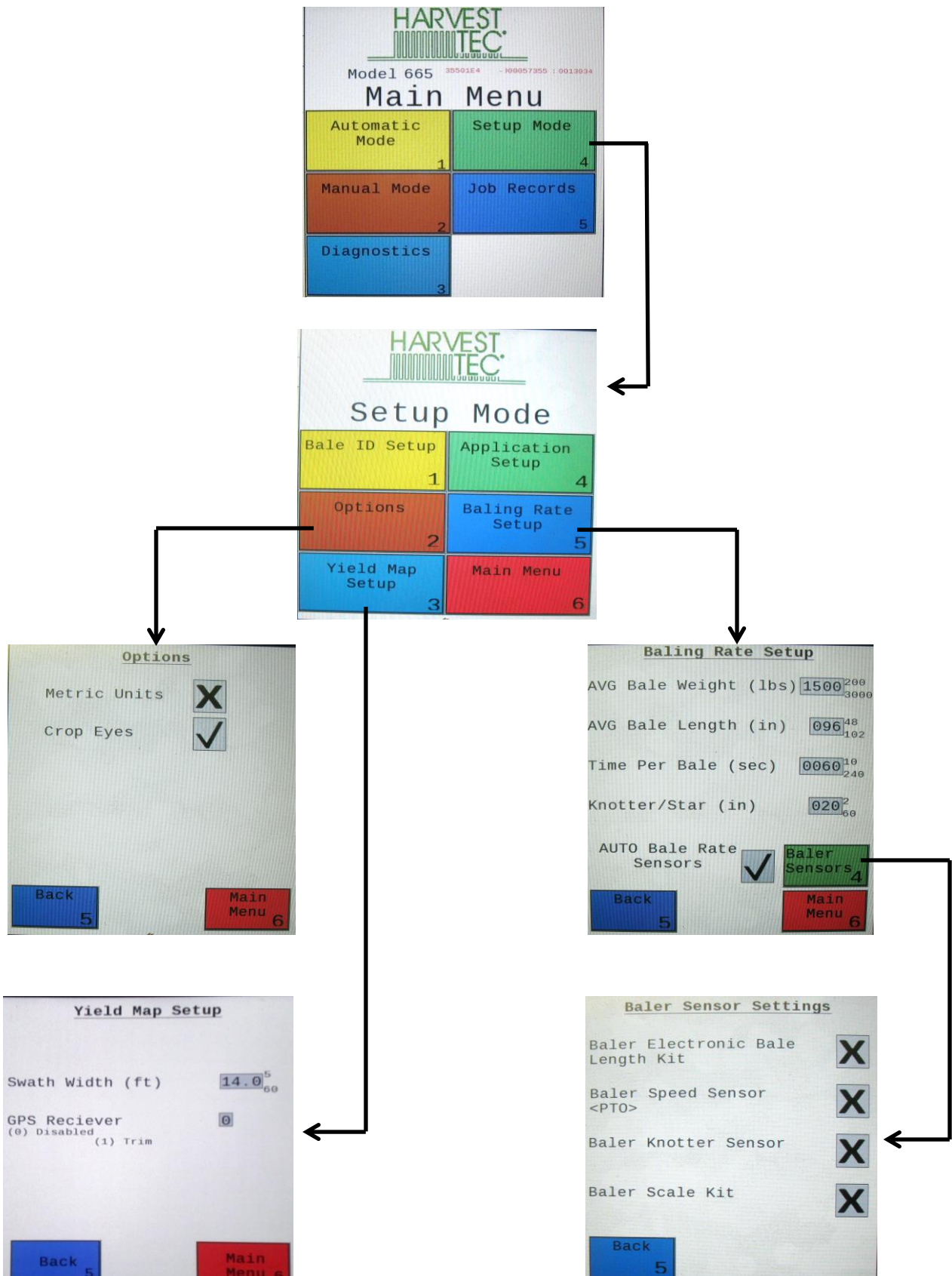

- All baler sensors need to be turned OFF.
- If a scale is being used, turn that sensor ON.

Job Records:

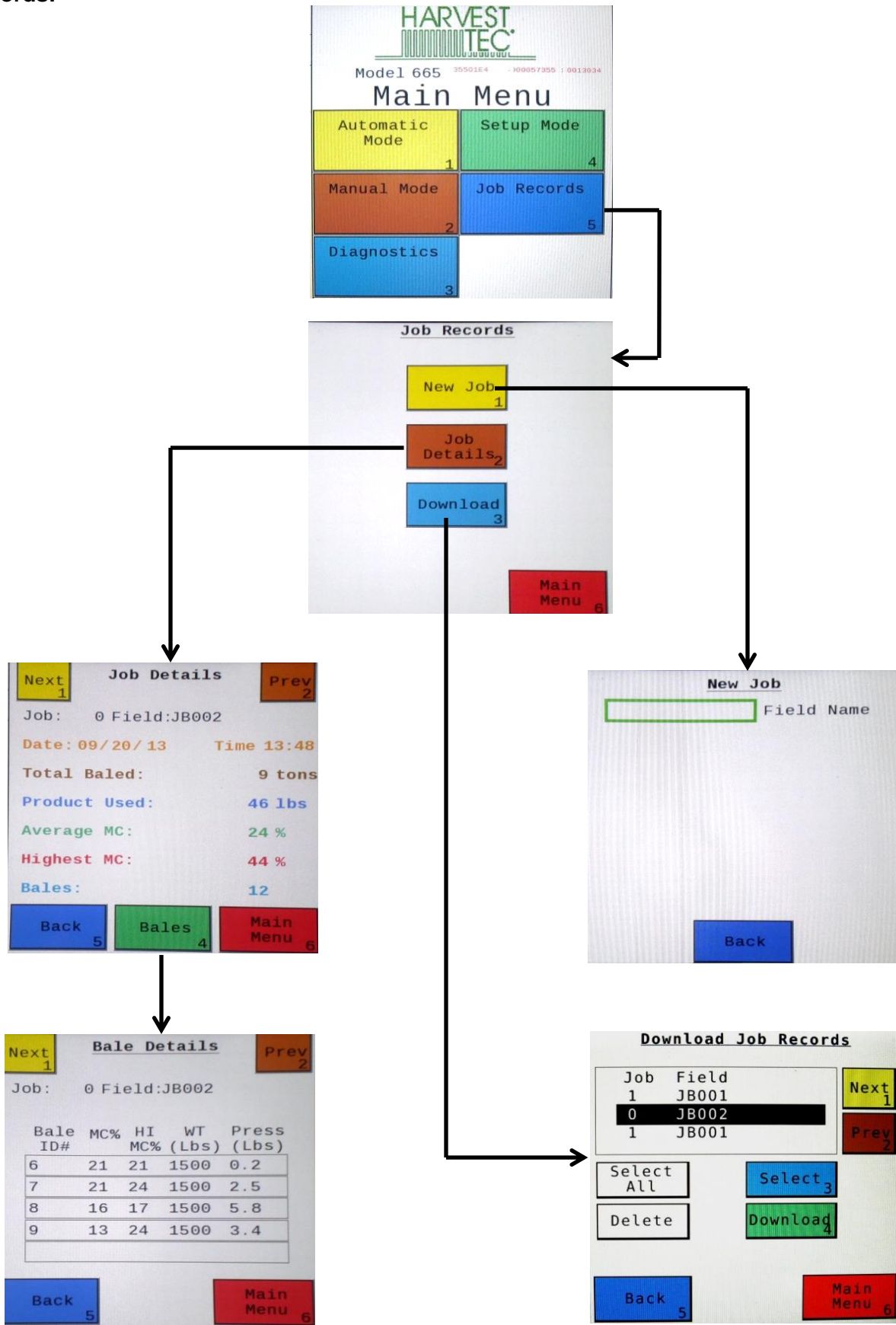

First Time and Annual Start Up Instructions

Checking and Priming the Pumps

1. Put 10 gal of water in tank and turn main ball valve on.
2. Inspect for any leaks or drips at this time. If any are found tighten or replace area or fitting.
3. Turn controller ON (turn key ON to the tractor).
4. Press the **SETUP MODE** key. Select **AUTO Baler Rate** sensors **OFF (A)** to disable bale rate sensors. Please **NOTE**: The DCP will reset each time the Auto Baling Rate Setting is changed. Make sure the **AVG Bale Weight** is 1500 lbs and the **AVG Baler Length** is 96 in. and **EST Baling Time** is 60 sec. Press the **MAIN MENU** key to return to the opening screen.
5. Press the **MANUAL MODE** key.
6. The screen shown below and to the right should appear.

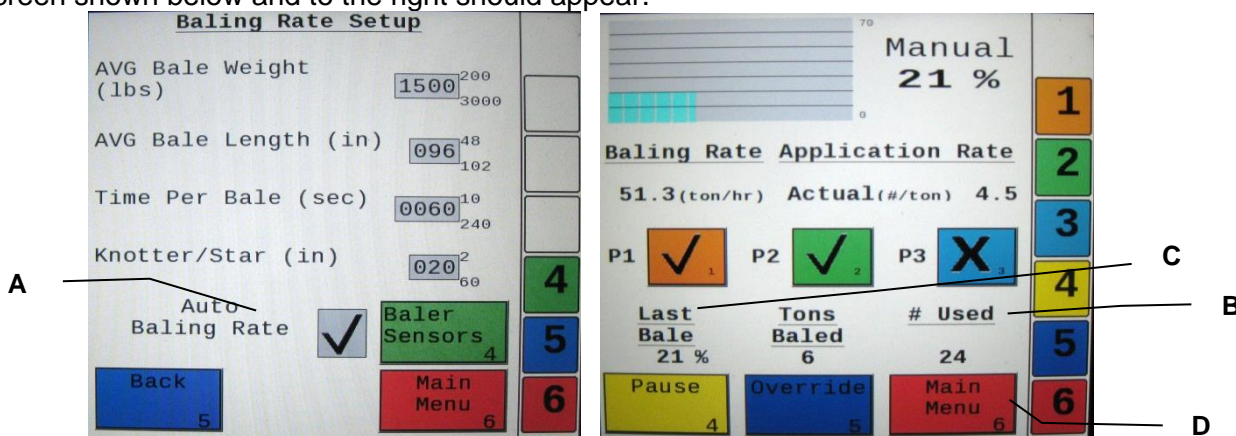

7. **NOTE: the system comes with the High tips already installed on the spray shield. Test the system with the tips you will use most often.** The rates listed below are for Harvest Tec buffered propionic acid. Other products will need to be collected and weighed to assure proper performance is achieved.
 - **With Low tips in:** Turn pump 1 on (P1). To do this press the underlined area on the screen which says **OFF**. The application rate should then read between 1.1 – 1.5 Lbs/Ton. Ideally, at 13.5 volts, the rate would read 1.3 Lbs/Ton.
 - Repeat the process for pumps 2 and 3 (P2 and P3). The application rate should read between 1.9 – 2.6 Lbs/Ton and 2.9 – 3.9 Lbs/Ton respectively. Ideally, at 13.5 volts, the rate for pump 2 would be 2.2 Lbs/Ton; pump 3 would be 3.4 Lbs/Ton.
 - **With High tips in:** Turn pump 1 on (P1). To do this press the underlined area on the screen which says **OFF**. The application rate should then read between 1.9 – 2.6 Lbs/Ton. Ideally, at 13.5 volts, the rate would read 2.2 Lbs/Ton.
 - Repeat the process for pumps 2 and 3 (P2 and P3). The application rate should read between 2.9 – 3.9 Lbs/Ton and 5.7– 7.7 Lbs/Ton respectively. Ideally, at 13.5 volts, the rate for pump 2 would be 3.4 Lbs/Ton; pump 3 would be 6.7 Lbs/Ton.
 - **With X-Hi tips in:** Turn pump 1 on (P1). To do this press the underlined area on the screen which says **OFF**. The application rate should then read between 3.0 – 4.0 Lbs/Ton.
 - Repeat the process for pumps 2 and 3 (P2 and P3). The application rate should read between 4.7 – 5.7 Lbs/Ton and 6.7 – 8.7 Lbs/Ton.
8. This process will also be used to prime the pumps whenever needed.
9. While running check for good spray pattern tips and verify that no parts of the system are leaking.
10. While doing these tests the **# Used** (B-Volume Used) near the bottom of the screen(B) should be counting up and verifies that the flow meter is functioning.
11. **Last Bale** (C) shows the average moisture content of the last bale made. This information will then be saved in your **Job Records**. Press the **MAIN MENU** (D) key to return to the initial start up screen.

NOTE: After completing First Time and Annual Start Up press the **SETUP MODE** key and turn the **AUTO Baler Rate** sensors back **ON** for normal operation. In normal operation it is recommended that the system be run with the **AUTO Baler Rate** sensors **ON**. (Also see Baling Rate to adjust bale weight, length, and time.)

Setting Up Application Rate and Bale Parameters for Initial Use

In the SETUP MODE you will set your initial application rate and baling rate.

Application Rate Setup

After pushing the **SETUP MODE** key in the **MAIN MENU** screen, the top left screen will show on the display:

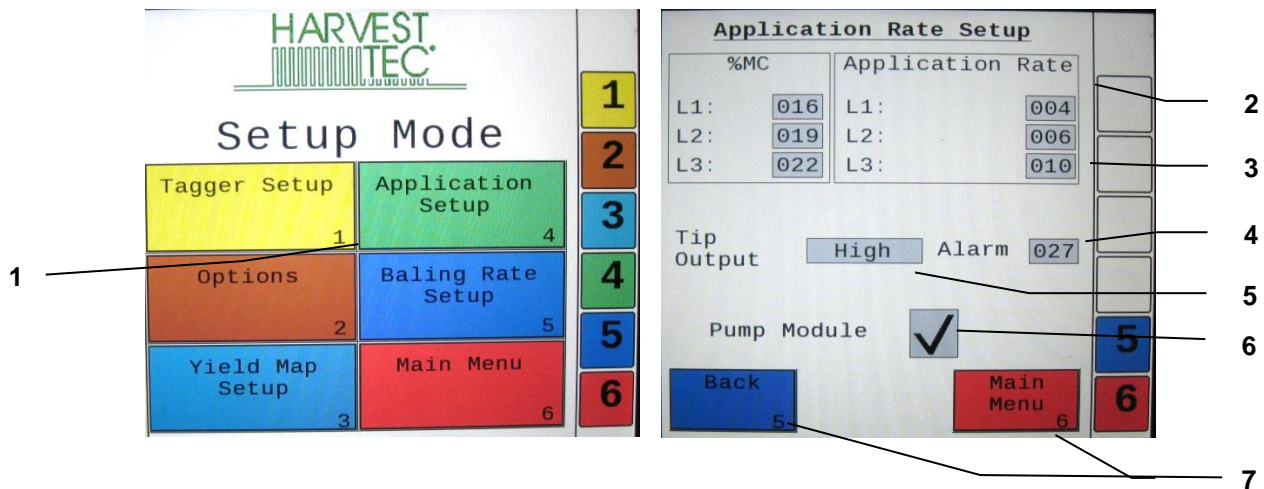

1. On this screen the operator will press the **APPLICATION SETUP** key.
2. Press any of the underlined numbers to the right of **%MC** to adjust their figures. Remember level 1 must be lower than level 2 and level 2 must be lower than level 3. Harvest Tec products recommend set points of 16, 19 and 22% MC levels. These are preset from the factory. Press **Back** to return to previous screen.
3. To change **Rate** of chemical application press any of the underlined numbers to the right of **RATE**. Remember level 1 must be lower than level 2 and level 2 must be lower than level 3. Harvest Tec products recommend rates of 4, 6, and 10 lbs/ton. These rates are preset from the factory. Press **Back** to return to previous screen. **IT IS THE OPERATORS RESPONSIBILITY TO FOLLOW THE RECOMMENDATIONS OF THE PRESERVATIVE. ONLY THE OPERATOR CAN APPLY THE PROPER RATE.**
4. To set the **Alarm** press on the underlined area and set the level at which you want the alarm to activate. **To turn the Alarm OFF, set level above 80.**
5. Press the underlined area next to **Tip Output** to cycle between the High and Low sets of tips. The High tips will cover outputs of 84-632 lbs/hr at approximately 21-63 tons/hr. The Low tips will cover outputs of 44-400 lbs/hr at approximately 11-40 tons/hr. Use the correct tip set for the field conditions.
6. The **Pump Module** needs to be turned **ON** for the pumps and flow meter to function.
7. Next press the **Back** key found on the bottom left hand side of the screen to return to **SETUP MODE** screen or press the **MAIN MENU** key on the bottom right hand side of the screen to return to the opening screen.

Baling Rate Setup

After pushing the **SETUP MODE** key in the **MAIN MENU** screen, the top screen should appear:

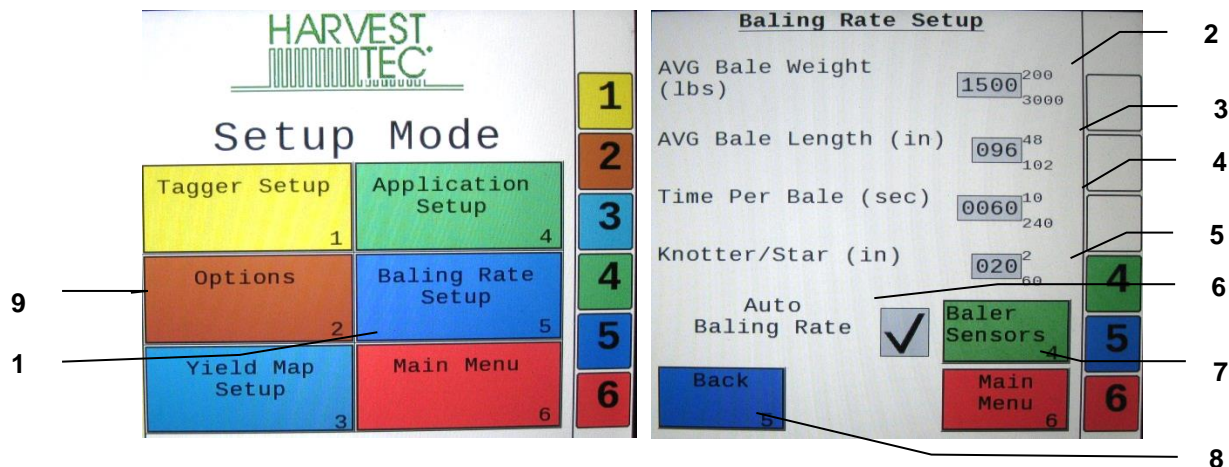

1. On this screen the operator will Select the **BALING RATE SETUP** key.
2. Select the number to the right of **AVG Bale Weight** (Lbs): to adjust the weight of your bales. The key pad shown will display. Select any number combination in this screen within the min/max limits. The information will remain until it is changed again.
3. Select the number to the right of **AVG Bale Length** (In): to adjust the length of your bales. Select any number combination in this screen within the min/max limits. The information will remain until it is changed again.
4. Select the number to the right of **Time Per Bale** (Sec): to adjust the time it takes to make a bale. Select any number combination in this screen within the min/max limits. The information will remain until it is changed again.
5. Select the number to the right of **Knotter/Star** to adjust the distance between the knotter and star wheel. To determine the distance, measure between the center of the starwheel and the center of the knotter. This is important so the job record correlates to the bale being made.
6. When the **AUTO Bale Rate** sensors are **ON** the applicator will calculate your tons per hour automatically. When the **AUTO Bale Rate** sensors are **OFF** a constant tons per hour (your inputed bale weight and time) will be used. Operating the unit with the AUTO Bale Rate sensors OFF will cause total tons per hour in Job Records to be left blank. Select the underlined word to toggle between ON or OFF. **First Time and Annual Setup is checking with AUTO Bale Rate sensors OFF.**
7. Selecting the **Baler Sensors** will allow you to use the Baler Sensor inputs in place of the standard applicator sensors if your baler is equipped with them from the factory. The sensors will come OFF as a default and the DCP will Reset to default when changed. If you choose to use the baler sensors be sure your baler is equipped with that option. For example, if you do not have an electronic bale length kit, turn that sensor OFF. The baler End of Row sensors are triggered once the PTO speed goes below 600RPM. The End of Bale sensor is triggered by the tie cycle alarm. The Bale Scale sensor is for the baler equipped with a Chute Scale. **Note: Baling on rough terrain or hills can cause the scale to give an inaccurate reading. Turn Bale Scale option OFF in the Baler Sensor Screen and use AVG Bale Weight (2) reading as weight of bale.**
8. Next select the **Back** key found on the bottom left hand of the screen to return to the **SETUP MODE** screen, or select the **MAIN MENU** key on the bottom right hand of the screen to return to the opening screen.
9. Select the **OPTIONS** key to adjust the system between metric and standard units. The **Crop Eyes** can also be turned **ON** or **OFF** in the **OPTIONS** screen. Select the ON/OFF next to Crop Eyes to change this setting. **Note: If you change languages you may need to reset the system from the MAIN MENU screen.**

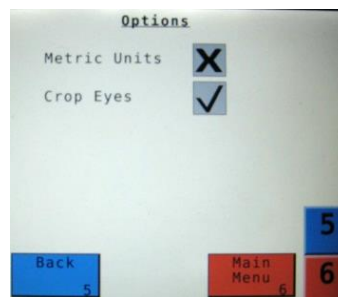

Operating Instructions

Automatic Mode will automatically apply product based on both hay moisture content sensed by the star wheels and the operator's preset parameters. (See **Setting Up System for Initial Use** to change any of these settings). **Manual Mode will apply preservative to the hay at a fixed rate regardless of the moisture content or baling rate.**

Automatic Mode

After pushing the **AUTOMATIC MODE** key in the **MAIN MENU** screen, the following screen should appear:

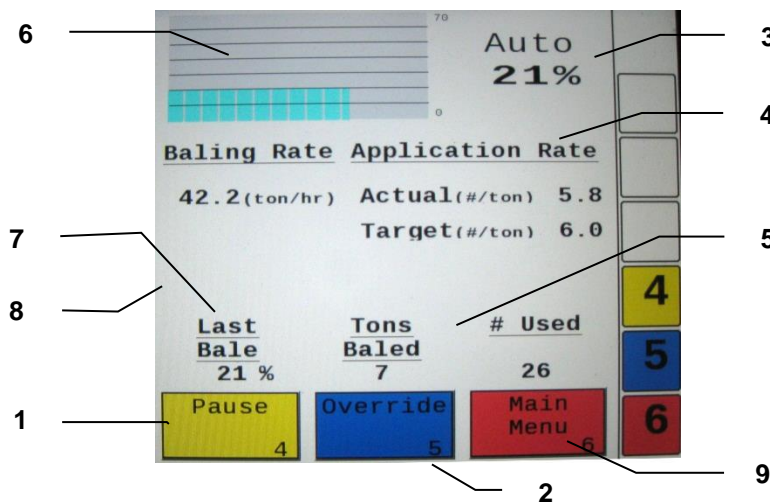

1. Push the **Pause** key (1) to stop application while in operation.
2. Push the **Override** key (2) to turn on all three pumps at the same time for full output of the system. Use this mode when going through a short area of wet crop.
3. The moisture content is shown in the upper right hand corner.
4. Baling Rate and Application Rate are shown in the middle. The operator sets the target application rate in the **SETUP MODE**. The ACTUAL rate should be within +/- one pound when running. The Baling Rate is also calculated in the **SETUP MODE**.
5. The totals on the bottom of the screen show the total **Tons Baled** and **# Used** (pounds of product used) for the current job. These numbers will reset to zero when a new Job Record is started. If operating with Bale Rate Sensors OFF total Tons Baled will be zero.
6. The **graph** shows the moisture trend from the past 90 seconds in 3 second intervals.
7. **Last Bale** shows the average moisture content for the last bale.
8. Any Status Alerts for the system will overlay the screen. Press the button to clear the Alert Message. See the Status Alerts section for information.
9. Press the **MAIN MENU** key to return to the opening screen.

Manual Mode

After pushing the **MANUAL MODE** key in the **MAIN MENU** screen, the following screen should appear:

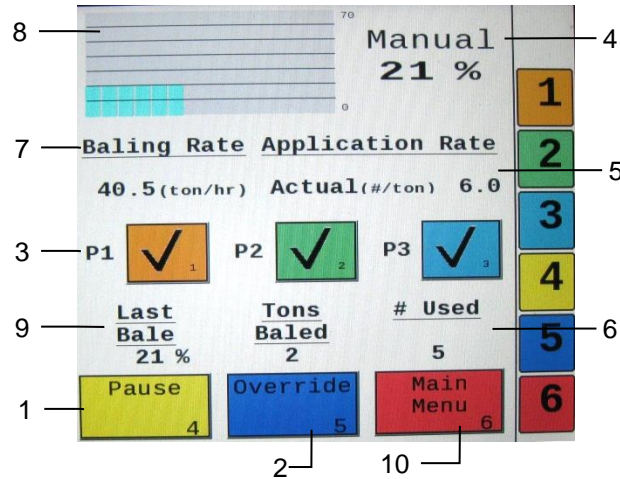

1. Push the **Pause** key (1) to stop application while in operation.
2. Push the **Override** key (2) to turn on all three pumps at the same time for full output of the system. Use this mode when going through a short area of wet crop.
3. In **MANUAL MODE** you can turn the pumps **ON** or **OFF** by pressing the underlined area next to the pump numbers. In **MANUAL MODE** (regardless of moisture, tons per hour or bale weight) the outputs of the pumps are fixed rates as follows:

Low output tips:

Pump 1 = 60 LBS/HR
Pump 2 = 100 LBS/HR
Pump 3 = 150 LBS/HR

High output tips:

Pump 1 = 100 LBS/HR
Pump 2 = 150 LBS/HR
Pump 3 = 300 LBS/HR

4. The moisture content is shown in the upper right hand corner.
5. Baling rate and Application rate are shown in the middle. The output of a pump can be checked by dividing the preset output (shown in step 3) by the baling rate. For example, if you have the high output tips in and are running all three pumps, your output is 550 lbs/hr. Given the **Baling Rate** shown on the above screen (40.5 tons/hr), the application rate should be about 13.5 lbs/ton (550lbs/hr divided by 40.5 tons/hr).
6. The Totals at the bottom of the screen show the total **Tons Baled** and **# Used** (pounds of product used) for the current job. These numbers will reset to zero when a new Job Record is started. If operating with AUTO Bale Rate sensors OFF total tons baled will be zero.
7. The **Baling Rate** is set in the **SETUP MODE** menu.
8. The graph shows the moisture trend from the last 90 seconds of baling (one reading every 3 seconds).
9. **Last Bale** shows the average moisture content for the last bale.
10. Press the **MAIN MENU** key to return to the opening screen.

Diagnostics

After pressing the **DIAGNOSTICS** key in the **MAIN MENU** screen, the screen on the left should appear:

1. To set date and time select the **Set Date/Time** (1) key. In the next screen enter the date (month, day, year format) followed by the time. When done select the **OK** key (2). NOTE: The clock uses military (or 24 hour) time.
2. Select the **Software Versions** key to check all software versions of modules attached to the Dual Channel Processor (DCP). The information will appear in the screen shown below right.

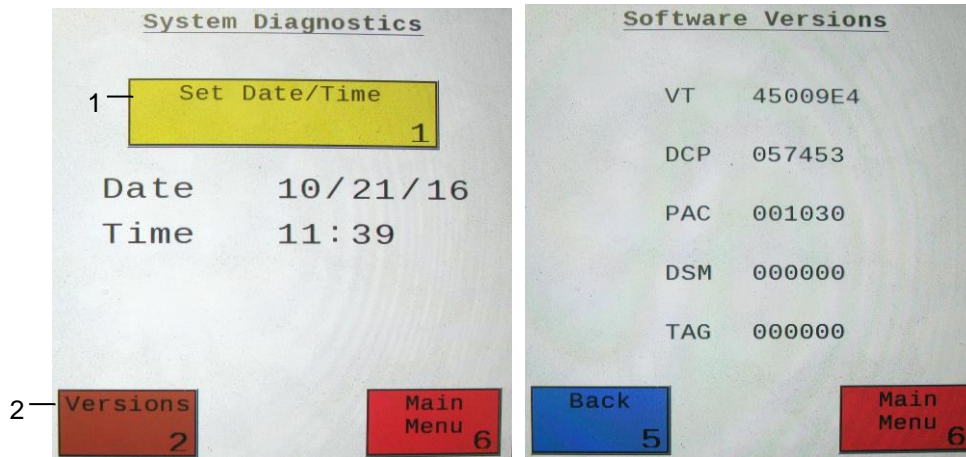

3. Press the **MAIN MENU** (4) key to return to the opening screen.

Job Records

After pushing the **JOB RECORDS** key in the **MAIN MENU** screen, the upper left screen below should appear:

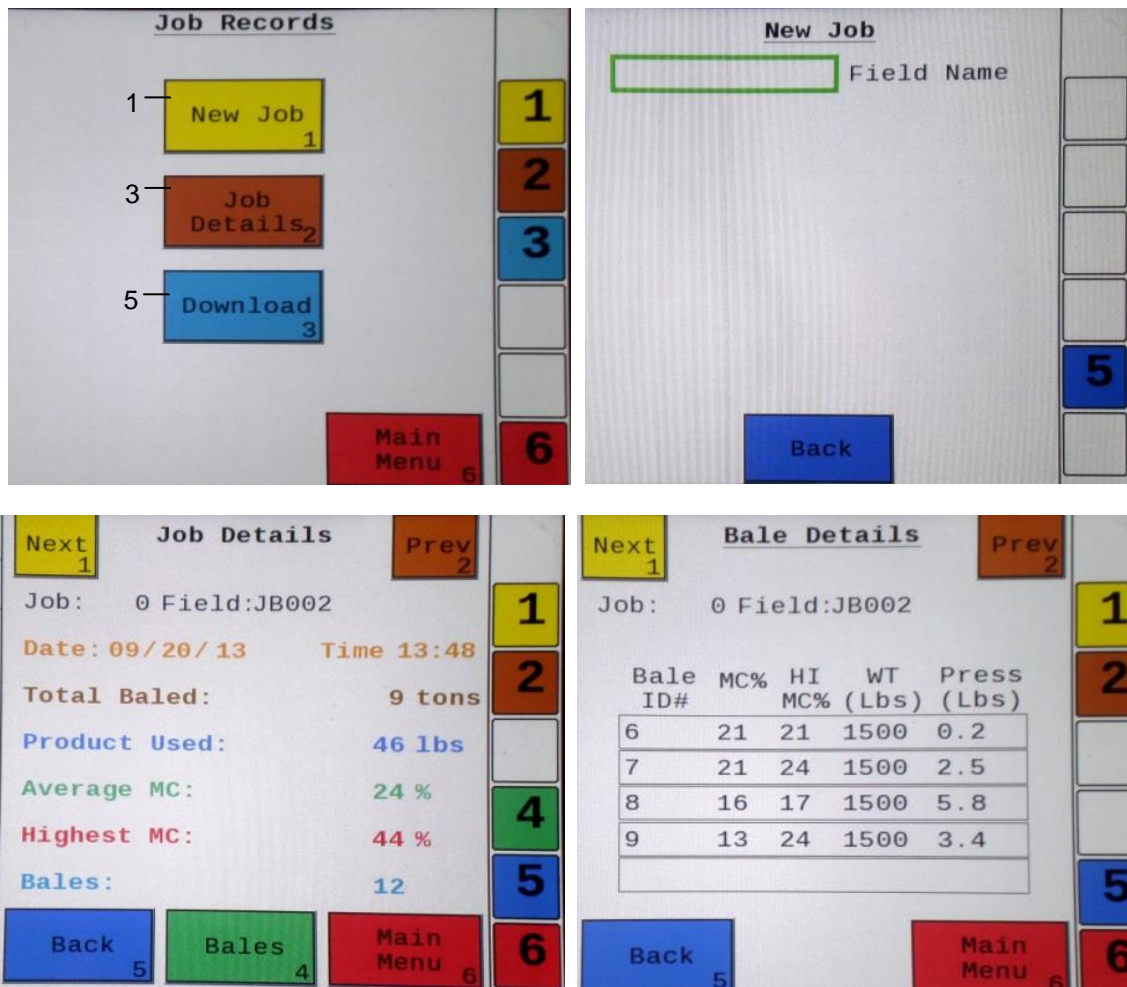

1. Selecting **New Job** will save all the previous bale records and open the **Field Name** screen.
2. Use the key pad in the Field Name screen to enter up to an eight character field name. Use the asterisk key to move on to the next letter or number if they are identical. Use the pound sign as a space between the characters. When you have completed the field name press enter.
3. Pressing **Job Details** will open the Job Details screen. Use the **Next** and **Prev** icons to view the different jobs. Job: 0 will always be your current and open job record. Press **Back** to go to the **Job Records** screen or **Main Menu** for the main screen.
4. Selecting **Bales** at the center bottom of the screen will open a **Bale Details** screen. This screen lets you look at the individual bale records for the first five bales made. Use the **Next** and **Prev** icons to scroll through five bales at a time. Select **Back** to go to the **Job Details** screen or **Main Menu** for the main screen.

Continued on the next page

Continued Job Records

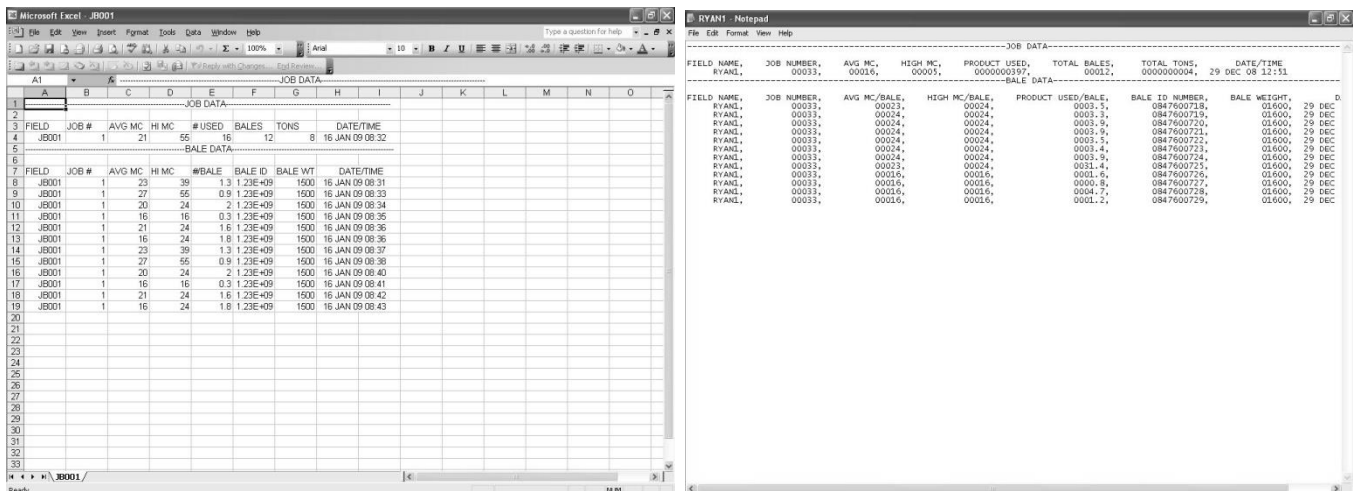

5. Selecting the **Download** key will open the Download Job Records screen. This screen lets you select jobs to download onto a USB drive. To download insert a USB drive into the port on the Dual Channel Processor. Select the job(s) you would like to download using the Next and Prev icons to highlight the job(s). Once the desired jobs are selected press the **Download** key. Press the **Download** key again to confirm. When the USB drive light goes off all the jobs selected will be saved. The jobs can then be opened on any computer with Excel or Notepad. To delete jobs highlight, select them and press **Delete** followed by pressing **Delete** again for confirmation. Press Back to go to the Job Records screen or Main Menu for the main screen.
6. Pressing the Select key will select or unselect the highlighted job.
7. Pressing the Select All key will select all jobs, except for the current job (0). To unselect press the Back key.
8. The job record in Excel will show as on the left above. The Bale ID column will need to be adjusted for proper viewing.
9. The job record in Notepad will show as on the right above. You will need to scroll right to see all the information.

iPad Integration Control Module

030-6672C

To operate the applicator, connect the iPad cord to the iPad Integration Control in the port indicated by:

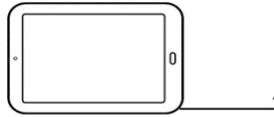

iPad Integration Control Light Signals

Green Slow Blink – Power supplied to the applicator system and the unit is going through its startup process. This will take approximately 25-35 seconds.



Green Double Blink – Indicating the iPad module recognizes the iPad but the app is not open or connected.

Green Solid Light – Module is connected to the app and is ready to operate.

*Recommended to use the USB cable included with the applicator kit (006-6672USBC)

Bluetooth Receiver Lights

Pre-2020 applicators equipped with Bluetooth receivers (030-6672B) are now equipped with lights to indicate both power and Hay App connection on the Apple iPad. Clean light regularly

Blinking Lights – System is waiting for the processor to connect, which could take up to 35 seconds.

Red Light – The Bluetooth receiver has power

Green Light – The Bluetooth receiver is connected to the Hay App.



****600 Series Applicators with serial number before DCP27000 will require the DCP to be sent to Harvest Tec for a required update in order to use the iPad Integration Module (030-6672C).**

Hay App version must be **at least 2.7.1 (or higher)** to operate with the iPad Integration Module

*Made for Apple iPad badge

Use of the Made for Apple iPad badge means that an accessory has been designed to connect specifically to the Apple product(s) identified in the badge and has been certified by the developer to meet Apple performance standards. Apple is not responsible for the operation of this device or its compliance with safety and regulatory standards.

Please note that the use of this accessory with an Apple product may affect wireless performance.

Maintenance

If you are unsure how to perform any of the maintenance steps have your local authorized dealer perform the tasks.

Maintenance Schedule

	Daily	10 hrs	400 hrs	Weekly	Monthly	Season
Diagnostics	X					X
Filter bowl cleaning		X				X
Tips & tip screen cleaning		X				X
Tank lid cleaning		X				X
Dielectric grease connections					X	X
Rebuild pumps			X			
Battery connections				X		X
Check valves			X			
Visually inspect hoses				X		X

Diagnostics: Follow the instructions in this manual to check Date and Version in the Diagnostics mode.

Filter Bowl Cleaning: The filter bowl is located in front of the applicators tank and is connected to the ball valve. Before cleaning the filter bowl all personal protective equipment must be worn (Face shield or goggles, chemically resistant apron, boots, and gloves).

Verify that the ball valve located next to the pump is turned off. Locate the filter bowl on the side of the pump manifold (A). Unscrew the bottom section of the filter bowl and remove the strainer. (B) Clean off any debris and soak in warm water with a mild soap if necessary. Once the screen is clean reinstall by following the directions in reverse.

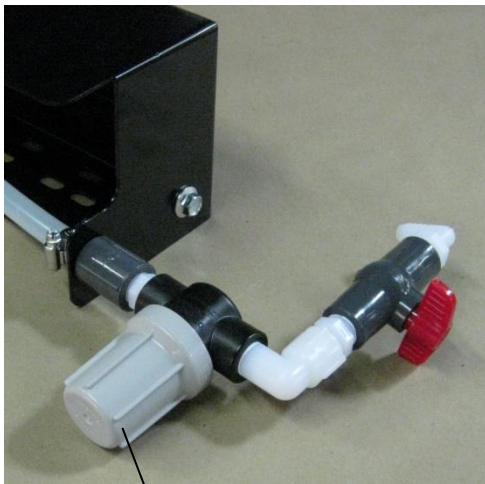

A

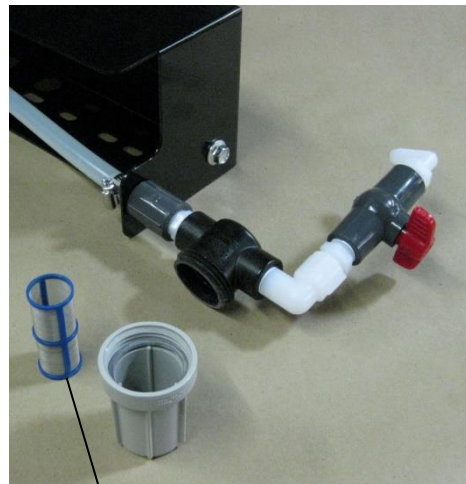

B

Tips and Tip Screen Cleaning: The spray shield assembly that holds the tips and tip screens is located above the pickup head.

Before cleaning the tips and screens all personal protective equipment must be worn (Face shield or goggles, chemically resistant apron, boots, and gloves).

Verify that the ball valve located next to the pump is turned off. Disconnect check valve nuts (A) and remove screens for cleaning (B).

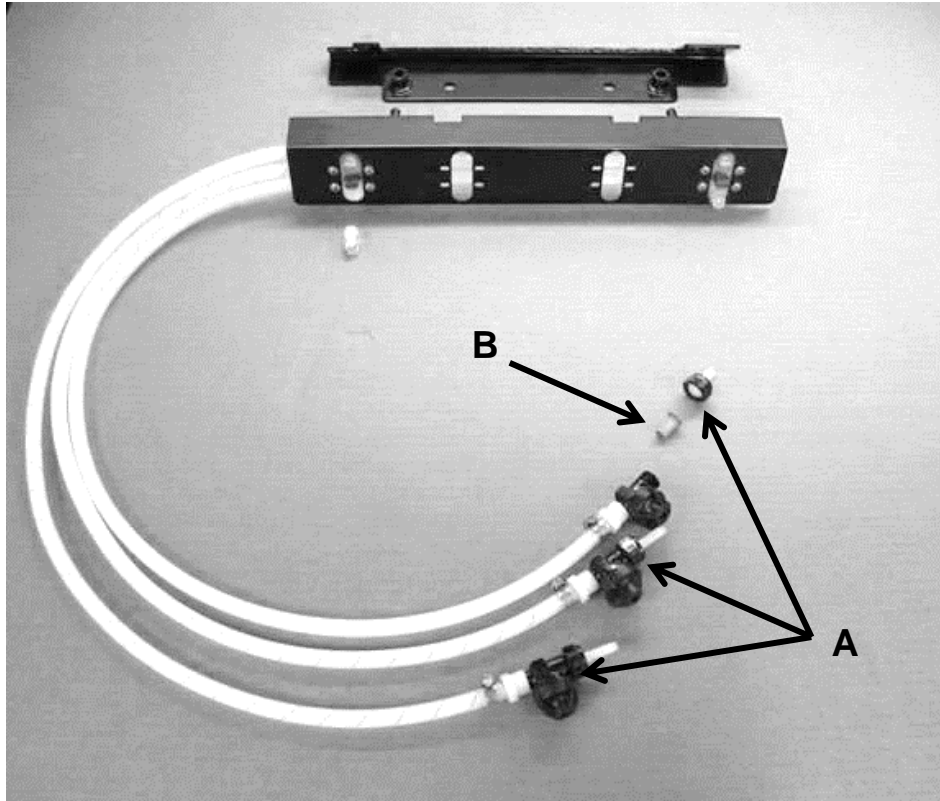

Tank Lid Cleaning: Before cleaning the tank lid all personal protective equipment must be worn (Face shield or goggles, chemically resistant apron, boots, and gloves).

The tank lid is located on the top of the tank. Use the supplied handle on the tank to secure your person and use the other hand to remove any debris from the top of the tank. Unscrew the tank lid and bring down ground level. Use compressed air clean out the tank breather (D). Once the breather is cleaned reinstall the cover.

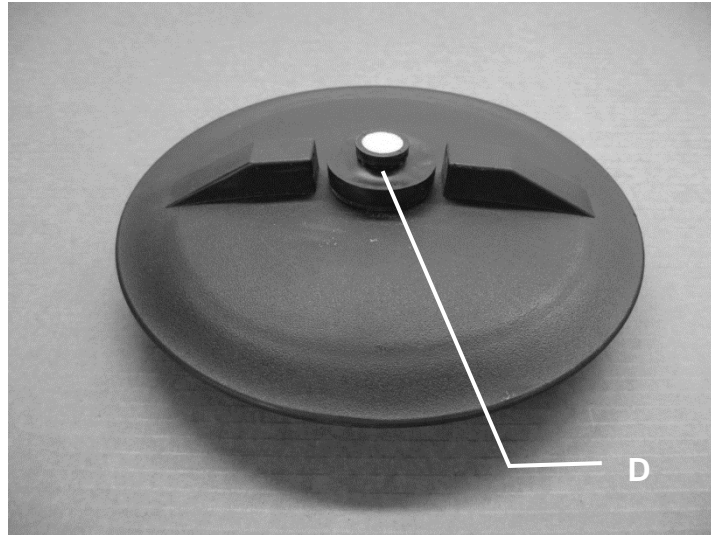

Dielectric Grease Connections: Disconnect all harnesses on the applicator, clean the connections, and repack with dielectric grease.

Rebuild Pumps: If Diagnostic or Manual mode show that the pumps are running lower than normal, a pump rebuild may be necessary. To do this rebuild the pump must be removed from the pump manifold. Pump rebuild is part no. 007-4581. A service pack that includes pump rebuilds and check valves is available from your local dealer.

Verify that the ball valve is turned off. Before working around the pumps all personal protective equipment must be worn (Face shield or goggles, chemically resistant apron, boots, and gloves). Remove pump from manifold. Follow rebuild instructions supplied with pump rebuild kit. Reinstall after rebuild is complete.

Battery Connections: Follow the batteries safety warnings and clean the battery connections. If the connections cannot be cleaned, replace harness.

Check Valves: Before servicing the check valves all personal protective equipment must be worn (Face shield or goggles, chemically resistant apron, boots, and gloves).

Verify the ball valve is turned off before service the check valves. Replace the intake check valves by the pumps (002-4566F) and the discharge check valves by the tip (004-1207VB).

Miscellaneous Maintenance:



1. Depending on the product being used, the system may need to be flushed with water at a regular interval (consult with manufacturer of the chemical.) If Harvest Tec product is being used, flushing is not necessary.
2. Although the pump can run dry, extended operation of a dry pump will increase wear. Watch the preservative level in the tank.
3. If you are using bacterial inoculants, flush your system daily after every use.

Winter Storage



1. Thoroughly flush the system with water.
2. Remove the filter bowl and run dry until the water has cleared out of the intake side.
3. Remove the red plug from the bottom of the pump, drain, and run the pump for 30 seconds or until it is dry.
4. Drain all lines on the outlet side.
5. Never use oils or alcohol based anti-freeze in the system.
6. For spring start-up, if the pump is frozen, turn off the power immediately to avoid burning the motor out or blowing a fuse. The pump head can be disassembled and freed or rebuilt in most cases. Check the fuses after the pump has been freed.
7. Disconnect power from the Precision Information Processor.
8. Remove display from tractor and store in a warm, dry place.

Tip Selection Guide

High Output Tips for Rates Requiring 84-632 lbs/hr. (Approximately 21-63 tons/hr)

	Red tips (Part #: 004-T8003-PT)	--Blue Hose	Pump 3
	Brown tips (Part #: 004-T80015-PT)	--Green Hose	Pump 2
	Pink tips (Part #: 004-T80001-PT)	--Clear Hose	Pump 1

Low Output Tips for Rates Requiring 44-400 lbs/hr. (Approximately 11-40 tons/hr)

	Brown tips (Part #: 004-T80015-PT)	--Blue Hose	Pump 3
	Pink tips (Part #: 004-T8001-PT)	--Green Hose	Pump 2
	Silver tips (Part #: 004-T800067-SS)	--Clear Hose	Pump 1

Wiring Diagram

- A. The Baler Power/Communication Harness (006-6650LS) will attach to the open port of the Tractor Harness (006-6650TM(E)) and run back to the Dual Channel Processor (006-6671LS). Connect the large plug of the Baler Power/Communication Harness (006-6650LS) to the bottom (shorter side) of the DCP.
 - B. Attach the Baler Interface Harness (006-6650VA) in between the short whip cable hardwired to the DCP and the main Power/Communication Harness (006-6650LS). Make sure Active Terminator removed from the top of the baler processor is attached to Baler Interface Harness (006-6650VA).
 - C. Install green terminator (006-5650Z) to the port labeled Modular Port on the Pump Controller (006-5672).
 - D. Attach moisture and bale rate harness (006-7303HX) as well as the end of bale harness (006-7400BBEXT) to the DCP (006-6671LS).
 - E. Attach the Pump Control Harness (006-5650F3M(E)) between the Pump Controller (006-5672) and the DCP (006-6671LS).
 - F. Connect Keyed Power Extension harness (006-5650K) to a keyed power source.
 - G. Connect the iPad Integration Control (030-6672C) to the Communication Harness (006-6650TM).
- Note: The Optional Port and the Data Transfer Port are not used in this application.

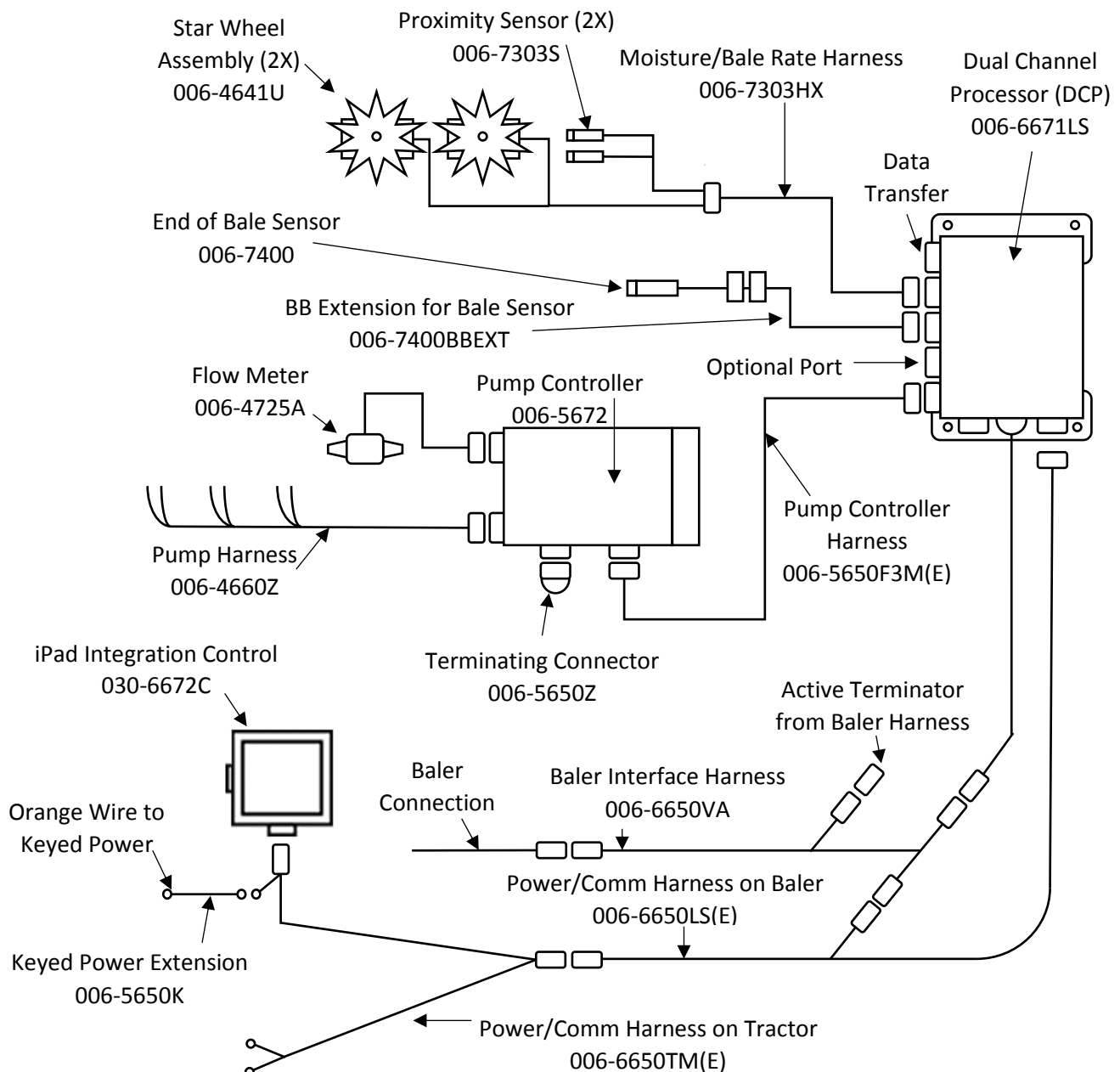

*Note: (E) indication is used for International Dealers

Pin Outs

Power/Comm Harness 006-6650TM at Hitch

Pin 1	Red	+12V Power to TSD
Pin 2	Red	+12V Power to DCP
Pin 3	Orange	Keyed Power
Pin 4	Gray	Shield
Pin 5	Green	HT Can Low
Pin 6	Yellow	HT Can Hi
Pin 7	Orange	Can1 Hi
Pin 8	Black	Ground from TSD
Pin 9	Black	Ground from DCP
Pin 10	Blue	Can1 Low



Power/Comm Harness 006-6650LS at Hitch

Pin 1	Red	+12V Power to TSD
Pin 2	Red	+12V Power to DCP
Pin 3	Orange	Keyed Power
Pin 4	Gray	Shield
Pin 5	Green	HT Can Low
Pin 6	Yellow	HT Can Hi
Pin 7	Orange	Can1 Hi
Pin 8	Black	Ground from TSD
Pin 9	Black	Ground from DCP
Pin 10	Blue	Can1 Low



iPad Integration Control / BLE on Harness 006-6650TM

Pin 1	Red	+12V Power from DCP
Pin 2	Black	Ground from TSD
Pin 3	Yellow	HT Can Low
Pin 4	Gray	Shield
Pin 5	Green	HT Can Hi
Pin 6	Orange	Can1 Hi
Pin 7	Blue	Can1 Low



006-6650VA to DCP Whip

Pin 1	Red	Can Power
Pin 2	Black	Can Ground
Pin 3	Yellow	HT Can Hi
Pin 4	Gray	Shield
Pin 5	Green	HT Can Low
Pin 6	Orange	Can1 Hi
Pin 7	Blue	Can1 Low



Pin Outs (continued)

006-6650VA to 006-6650 LS

Pin 1	Red	Can Power
Pin 2	Black	Can Ground
Pin 3	Yellow	HT Can Hi
Pin 4	Gray	Shield
Pin 5	Green	HT Can Low
Pin 6	N/A	
Pin 7	N/A	



006-6650VA Harness to Baler Plug

Pin A	N/A	
Pin B	Red	TBC Power
Pin C	N/A	
Pin D	Gray	TBC Ground
Pin E	Orange	Can1 Hi
Pin F	Blue	Can1 Low

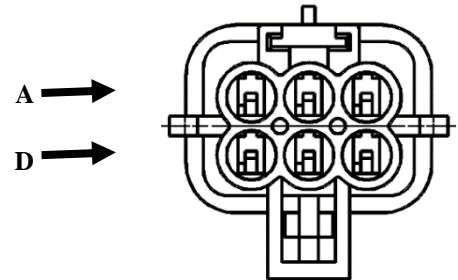

Main Power Connector on DCP

Pin 1	Red	+12V Power from tractor
Pin 2	Black	Ground from tractor
Pin 3	Orange	Keyed power

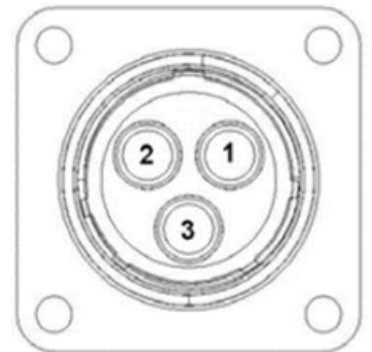

Star Wheel and Bale Rate Sensor Connector on DCP

Pin 1	Blue	+12V Power
Pin 2	Orange	Ground
Pin 3	Black	Signal for sensor 1
Pin 4	White	Signal for sensor 2
Pin 5	N/A	
Pin 6	N/A	
Pin 7	N/A	
Pin 8	Violet	Star wheel input 1
Pin 9	Brown	Star wheel input 2



End of Bale Sensor on DCP

Pin 1	Brown	Sensor Power
Pin 2	Blue	Sensor Ground
Pin 3	N/A	
Pin 4	Black	Signal from Sensor

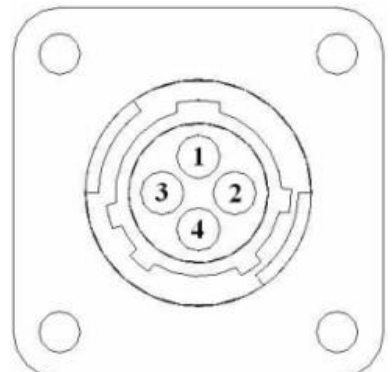

Pin Outs (continued)

Pump Communication Plug on DCP

Pin 1	Red	+12V Can
Pin 2	Red	+12V Power
Pin 3	Gray	Shield
Pin 4	Green	Comm Channel OH
Pin 5	Yellow	Comm Channel OL
Pin 6	Blue	Comm Channel IH
Pin 7	Orange	Comm Channel IL
Pin 8	Black	Can Ground
Pin 9	Black	Power Ground
Pin 10	N/A	

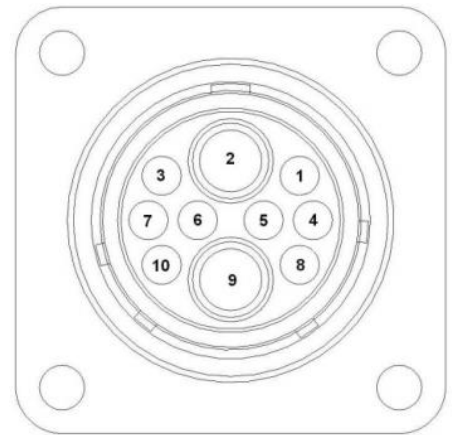

Pump Connection Colors

Pin 1	Black with Orange Stripe	Pump 1 Ground
Pin 2	Black with Green Stripe	Pump 2 Ground
Pin 3	Black with Yellow Stripe	Pump3 Ground
Pin 4	N/A	
Pin 5	Orange with Black Stripe	Pump 1 Positive
Pin 6	Green with Black Stripe	Pump 2 Positive
Pin 7	Yellow with Black Stripe	Pump 3 Positive

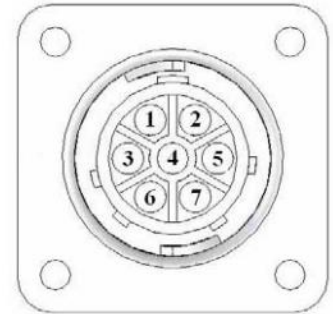

Flow Meter Connection on Pump Controller

Pin 1	White	+5-12V Power
Pin 2	Green	Ground
Pin 3	Brown	Signal
Pin 4	Black	Shield

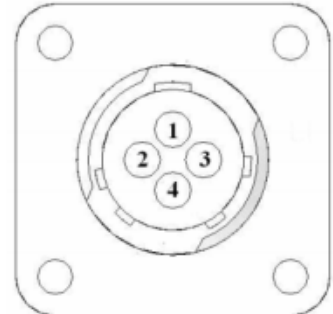

Connector for Crop Eyes on DCP

Pin 1	Red	+12V Power
Pin 2	Black	Ground
Pin 3	White	Signal
Pin 4	N/A	

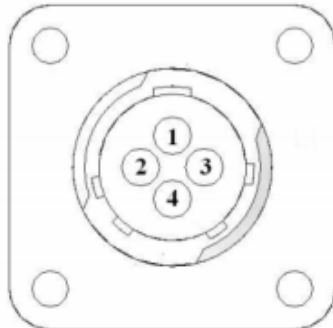

Common Questions

1. How do I turn the system on/off?

Turn the key in the tractor to the on position.

2. How to get in the LBS/TON, MC%, and TONS/HR menus?

In the **Main Menu** press the **Setup Mode** option. From this screen you can change your application rates and how much product is applied. See the section on **Setting Up For Initial Use** for a detailed explanation of this process.

3. The unit is stuck in the MC% screen.

In the MC% screen, level 1 must be less than level 2, and level 2 must be less than level 3. For example, if level 1 is set at 16, level 2 must be set at 17 or higher, and level 3 must be set higher than level 2.

4. How does Override work?

Override turns on all three pumps at full output. The pumps will remain at full output until the operator turns these pumps off by pressing the **Override** key again.

5. The flow meter reading is more or less than the programmed level set in the box.

Some variation in flow meter readings compared to the programmed set point is normal due to factory tolerances on the pump motors as well as varying tractor voltages inputted to the control box. The flow meter reading is an accurate measure of how much product is actually being applied. The set points then will need to be adjusted if you want to attain a different flow meter reading.

6. Why don't all the pumps turn on even at higher application rates?

The selections of what pumps turn on when are automatically controlled by the control box's flow rate look up chart. Thus, not all the pumps turn on at once and the combination of what pumps turn on when is automatically controlled by the software.

7. The moisture content displays "LO" or "HI" all the time.

When the moisture content display does not change frequently while baling, there is likely a faulty star wheel connection. One of the first places to check is inside the white star wheel block. Check to see if the electronic swivel is in the star wheel shaft and check to see that the star wheel shaft is not working out of the block. Also, check all star wheel wires and connectors to see if there is a continuity or grounding problem.

8. Should the battery connections be removed before jump starting or charging a battery?

Yes. Anytime the tractor will have voltage going up rapidly the connections should be removed.

9. How can I turn the optional hay indicators Crop Eyes On/Off from the cab?

From the **Setup Mode** screen press **Options**. Press the **On/Off** underlined area next to **Crop Eyes**.

10. Bale scale does not give a consistent reading.

Baling on rough terrain or hills can cause the scale to give an inaccurate reading. Turn Bale Scale option OFF in the Baler Sensors Screen and use AVG Bale Weight reading as weight of bale.

11. What do the lights on the 030-6672B indicate?

Pre-2020 applicators were equipped Bluetooth receivers (030-6672B) and are now equipped with lights to indicate both power and Hay App connection on the Apple iPad. Red Light – The Bluetooth receiver has power. Green Light – The Bluetooth receiver is connected to the Hay App.

Troubleshooting

Problem	Possible cause	Solution
Pump will not run.	1. No voltage to DCP or Pump controller.	1. Check for short, low voltage, and replace fuse(s) if necessary.
	2. Pump locked up.	2. Clean or rebuild pump if motor is OK.
	3. Damaged wire.	3. Repair damaged wire.
	4. Fuse blown on Pump controller.	4. Replace fuse and check pump for short in wire or locked motor.
Pump runs but will not prime.	1. Air leak in intake.	1. Tighten fittings on intake side.
	2. Clogged intake.	2. Clean.
	3. Restricted outlet.	3. Check and clean tips.
	4. Check valve on the outlet is stuck closed.	4. Clean or repair check valve.
	5. Dirt inside pump.	5. Replace pump check valve.
Pump does not develop enough output.	1. Air leaks or clogs on inlet side.	1. Tighten or clean filter bowl assembly.
	2. Pump worn or dirty.	2. Rebuild pump.
Moisture reading errors (high or low)	1. Wire disconnected or bad connection between star wheels and DCP	1. Reconnect wire.
	2. Low power supply to DCP	2. Check voltage at box. (Min of 12 volts required.) See Diagnostics section of manual.
	3. Wet hay over 75% moisture	
	4. Ground contact with one or both star wheels and BMP	4. Reconnect.
	5. Short in wire between star wheels and DCP.	5. Replace wire.
	6. Check hay w/ hand tester, verify	6. Contact Harvest Tec if conditions
Moisture readings erratic.	1. Test bales with hand tester to verify that cab monitor has more variation than hand tester.	
	2. Check all wiring connections for corrosion or poor contact.	2. Apply dielectric grease to all connections.
	3. Check power supply at tractor. Voltage should be constant between 12 and 14 volts.	3. Install voltage surge protection on tractors alternator.
Flow meter readings do not match up with product usage.		
Product is less than actual product used.	1. Voltage supplied to meter is less than 6 volts.	1. Check for a min of 6 volts supplied at Pump controller.
	2. Wiring short in signal to baler mounted processor.	2. Inspect wire and replace if necessary.
	3. Clog in meter.	3. Back flush with water. DO NOT USE AIR.
	4. Using product other than Harvest Tec	4. Catch and weigh product to check outputs.
Product shown is more than actual product used.	1. High voltage supplied to the meter.	1. Check voltage at Pump controller. Max of 18 volts.
	2. Light interference with meter.	2. Reflection into meter can cause a high reading. Move meter or protect from sunlight.
	3. Air leak in intake.	3. Look for air bubbles in line. Replace line or other defective area that is allowing air into the system.
	4. Using product other than Harvest Tec	4. Catch / weigh product to check outputs.
System leaks product out of tips after shut down.	1. Dirty or defective check valves.	1. Clean or Replace.

Troubleshooting (continued)

Terminal reads under or over power.	1. Verify with multi-meter actual voltage. Voltage range 12-14V	1. Clean connections and make sure applicator is hooked to battery.
System does not pause at end of row when using 474A crop eyes.	1. Short in cable. 2. Damaged sensor. 3. Bad alignment of sensors	1. Replace cable. 2. Replace sensor 3. Check 474 manual for alignment instructions
Bale rate displays zero.	1. Bale rate sensors are reversed. 2. Short in cable. 3. Damaged sensor.	1. Switch the sensors next to the star wheel. 2. Replace cable. 3. Replace sensor.
Display says PAC error	1. The DCP and Pump controller are not communicating. 2. Broke connection between the display and DCP or PAC and DCP.	1. Check all connections at DCP and Pump controller including terminating resistors. 2. Check, clean, and tighten connections
Bale scale not giving accurate reading	Load cell calibration is off	1. Refer to your scale owner's manual for instructions on recalibrating.
Can't select moisture / preservative information on baler run screen	DCP not selected in baler software	Select DCP for the moisture option in machine setup. See Communicating through ISOBUS Monitor section in operation manual
Blue Tag / Nozzle icon flashing on baler run screen	CNH ECU is set to communicate with DCP, but DCP is not communicating correctly with baler	DCP has to be reconfigured. Contact your dealership to send back to Harvest Tec for repair.
Warning: HT system type conflicts with machine setup	CNH Baler ECU recognizes that a Harvest Tec system is installed, but system is not configured correctly.	DCP has to be reconfigured. Contact your dealership to send back to Harvest Tec for repair.
'?' or '---' for moisture values are being shown on baler run screen	CNH software must see a stuffer cycle before it will update the moisture values	Simulate a stuffer cycle on baler, or wait until baling in the field and the moisture will update
Job records are showing as symbols or incorrect values	The job file is corrupted on SD card	Write down all job record information the operator wishes to keep. Update the DCP software to the most current version available on the Harvest Tec website. Delete all existing jobs by selecting all in the download screen and pressing delete. Be sure to start a new job and verify it is saved by checking job details screen.
Values in auto / manual mode are obscure	The job file is corrupted on SD card	
Can't download job records, stuck at "Saving to USB Stick"	One of more jobs are corrupted on SD card. If "saving to USB" is displayed, some jobs have been downloaded correctly.	
Can't download job records, stuck at "Searching"	If searching is displayed then the first job is corrupted and download will not work.	
No green baler sensors button in bale rate setup screen	DCP is not configured to communicate with baler	If baler is compatible, Harvest Tec can reconfigure DCP to correct setting. Contact your dealership to send back to Harvest Tec for repair.
Bale rate goes to zero and prox sensors/star wheels check out fine	DCP is set to use "Bale Rate Sensor" from baler in calculation and baler does not have this install	Turn off Bale Rate Sensor in baler sensors screen, make sure Auto baling rate is turned on in baling rate screen
"Cannot open USB" message when trying to download	DCP does not see a USB stick in the Data Transfer port	Make sure the operator has the USB in the DCP with good connect and not the VT port in the cab of the tractor.
Bluetooth Receiver lights will not illuminate	1. Bluetooth receiver not connected 2. Harness disconnected	1. Check connections and voltage. Minimum 12.5V needed.
	<p>Blinking Lights – System is waiting for the processor to connect, which could take up to 35 seconds.</p> <p><i>Red Light</i> – The Bluetooth receiver has power</p> <p><i>Green Light</i> – When the proper active connection is selected in the Hay App menu, the green light will indicate connection with the iPad.</p>	

Parts Breakdown

Tank and Saddle Legs



<u>Ref</u>	<u>Description</u>	<u>Part Number</u>	<u>Qty</u>	<u>Ref</u>	<u>Description</u>	<u>Part Number</u>	<u>Qty</u>
1	Tank	005-9218	1	7	Tank Leg Mount	001-6707MHD1	2
2	Elbow	003-EL1212	2	8	Cross Beam	001-6707MHD2	1
3	1/2" tank fitting	005-9104	2	9	1/2" hose	002-9001	2
4	Tank straps	001-6707P	2	NP	Elbow	003-EL3434	1
6	Handrail	001-6707HR	1	NP	Elbow	003-EL3412	1
5	Tank lid	005-9022H	1	NP	3/4" tank fitting	005-9100	2

Pump Manifold

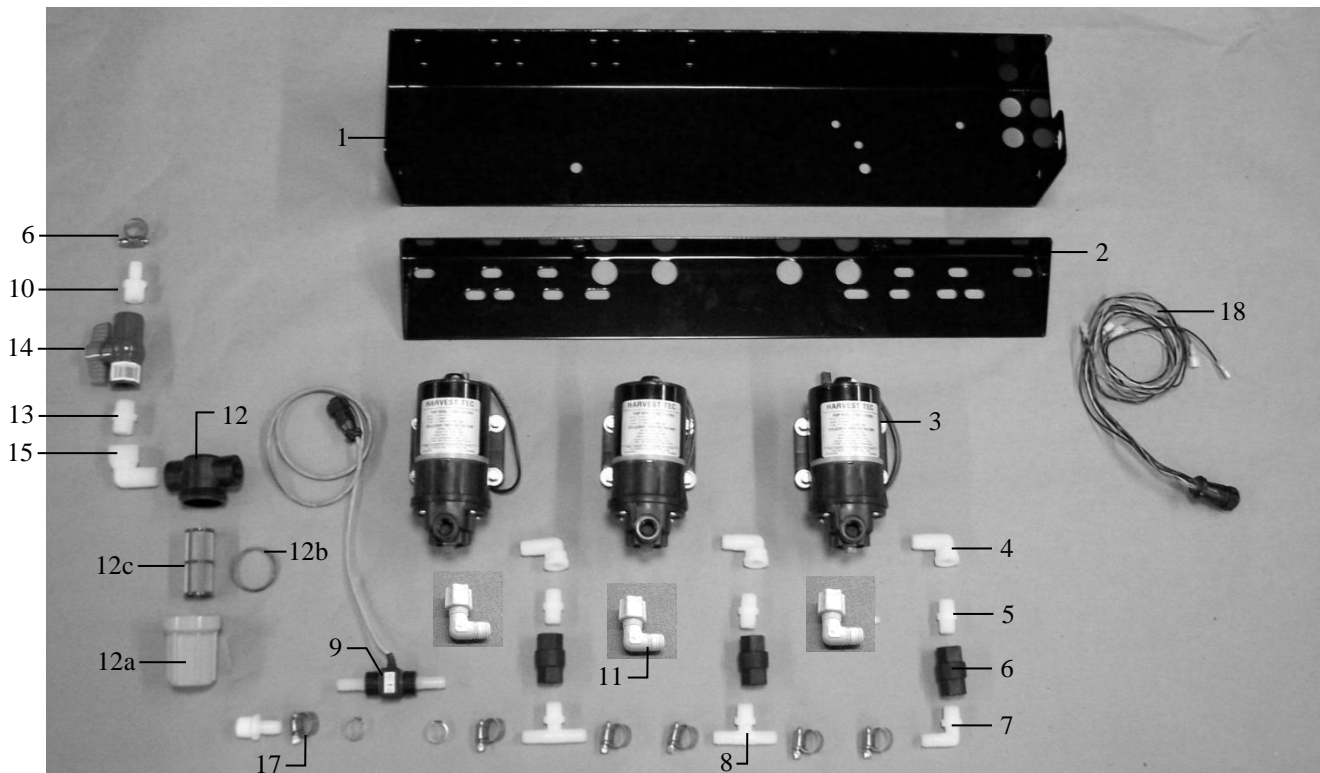

<u>Ref#</u>	<u>Description</u>	<u>Part#</u>	<u>Qty</u>
1	Pump plate	001-4646D	1
2	Mounting Bracket	001-4646C	1
3	Pump	007-4120H	3
4	Street elbow fitting	003-SE38	3
5	Nipple fitting	003-M3838	3
6	Check valve	002-4566F	3
7	Elbow fitting	003-EL3812	1
8	Tee fitting	003-T3812HB	2
9	Flow meter assembly	006-4725A	1
10	Straight fitting	003-A1212	2
11	Jaco fitting	003-JEL1238	3
12	Filter bowl assembly	002-4315-100	1
12a	Filter bowl only	002-4315F	1
12b	Filter bowl gasket	002-4315D	1
12c	Filter bowl screen	002-4315A	1
13	Nipple fitting	003-M1212	1
14	Ball valve	002-2212	1
15	Street elbow fitting	003-SE12	1
16	Hose clamp	003-9003	7
17	Hose clamp (Flow Meter)	003-9005	2
18	Pump Cable	006-4660Z	1
NP	Elbow	003-EL1212	1
NP	Pump rebuild kit (1 per pump)	007-4581	1
	Complete Pump Assembly	030-4646	

695BBHD Star Wheels

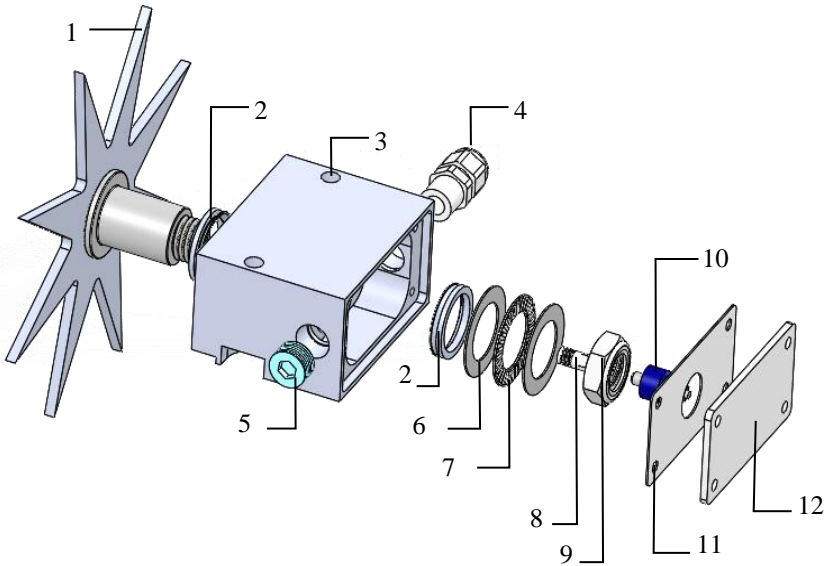

<u>Ref</u>	<u>Description</u>	<u>Part#</u>	<u>Qty</u>
1	Univ Star Wheel	006-4641S	1
2	Dust Seal	006-4641DSL	2
3	Univ Star Block	006-4641Q	1
4	3/8" NPT Cable Grip	008-0821A	1
5	3/8" NPT Plug	003-F38	1
6	Thrust Washer	006-4641TA	2
7	Thrust Bearing	006-4641TB	1
8	Swivel Insert	006-4642B	1
9	3/4" Short Nut	006-4641U	1
10	Rotary Swivel	006-4642A	1
11	Cover Gasket	006-4641RG	1
12	Univ Block Cover	006-4641R	1
NP	Prox Sensor Holder	006-4644SS	1
NP	SW Reinforcement	001-4644BBHD	1
Star Wheel Assembly (Ref 1-12)		030-4641U	

Bale Rate Sensors

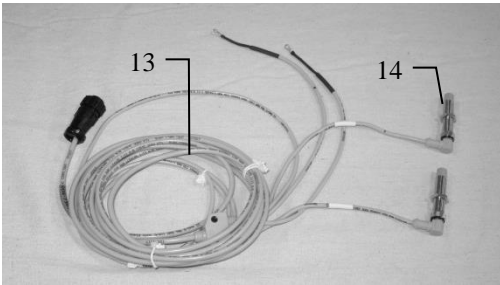

<u>Ref</u>	<u>Description</u>	<u>Part Number</u>	<u>Qty</u>
13	Moisture & Bale Rate Harness	006-7303 HL(E)	2
14	Bale Rate Sensor	006-7303S	1
NP	Moisture & Bale Rate Harness (600BBHD)	006-7303HX	1

Hose and Drain Fill Line

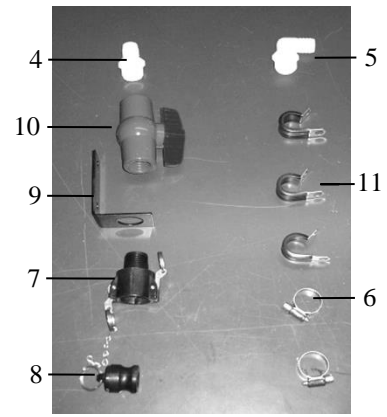
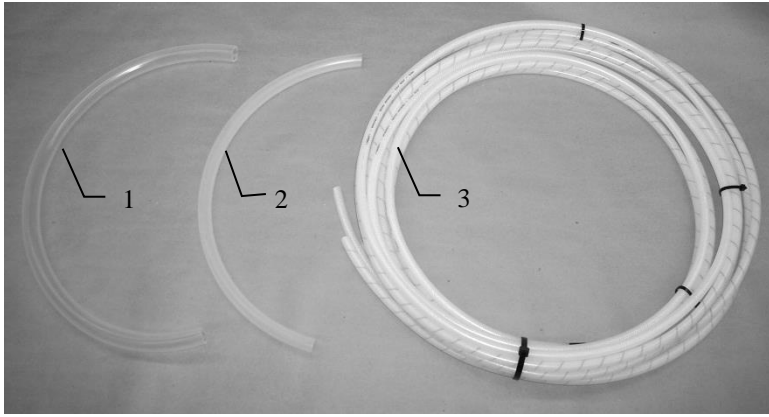

<u>Ref</u>	<u>Description</u>	<u>Part Number</u>	<u>Qty</u>	<u>Ref</u>	<u>Description</u>	<u>Part Number</u>	<u>Qty</u>
1	3/4" Hose (tank to drain/fill valve)	002-9002	10ft	7	Female Coupler	002-2204A	1
2	1/2" Hose (tank to filter)	002-9001	6ft	8	Male Coupler	002-2205G	1
3	Triple weld hose (pumps to tips)	002-9016	25ft	9	Valve Holder	001-6702H	1
		002-9016B	25ft				
		002-9016G	25ft				
	Three hose assembly	030-9016LS	1	10	Ball valve	002-2200	1
4	Straight Fitting	003-A3434	1	11	Jiffy Clip	008-9010	3
5	Elbow	003-EL3434	1				
6	Hose Clamps	003-9004	2				

695BBDHD Controls and Harnesses

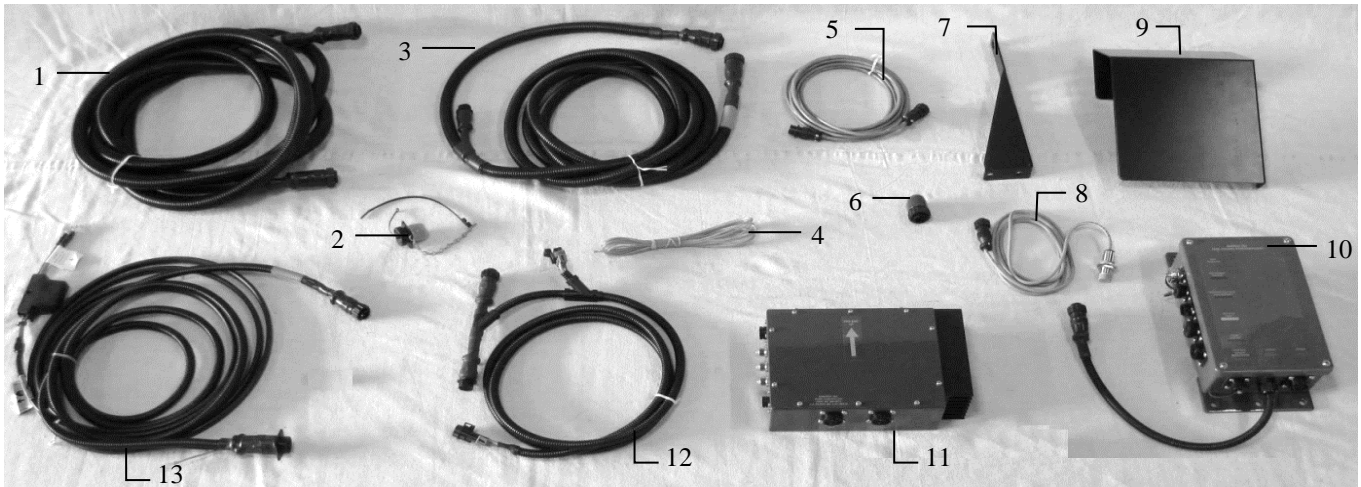

<u>Ref</u>	<u>Description</u>	<u>Part Number</u>	<u>Qty</u>
1	Modular Power/Comm Harness 20'	006-5650F3M(E)	1
2	Dust Plugs	006-5651PLUGS	1
3	DCP Baler Harness 15'	006-6650LS	1
4	Key Switch Wire	006-5650K	1
5	EOB Extension for CNH BB Series	006-7400BBEXT	1
6	Terminating Connector 600 Series	006-5650Z	1
7	End of Bale Sensor Bracket	001-4648	1
8	End of Bale Sensor 600 Series	006-7400	1
9	DCP Shield/Cover	001-5650X	1
10	DCP Main Control LS 600 AUTO	006-6671LS	1
11	Pump Controller	006-5672	1
12	DCP Baler ISO/VT Harness	006-6650VA	1
13	DCP Tractor Harness	006-6650TM(E)	1
NP	USB Cable	006-6672USBC	

*Note: (E) indication is used for International Dealers



Part #: 030-6672C

Harvest Tec Model 4636B Installation Kit (Includes 4536B & 6707WG4 Kits)

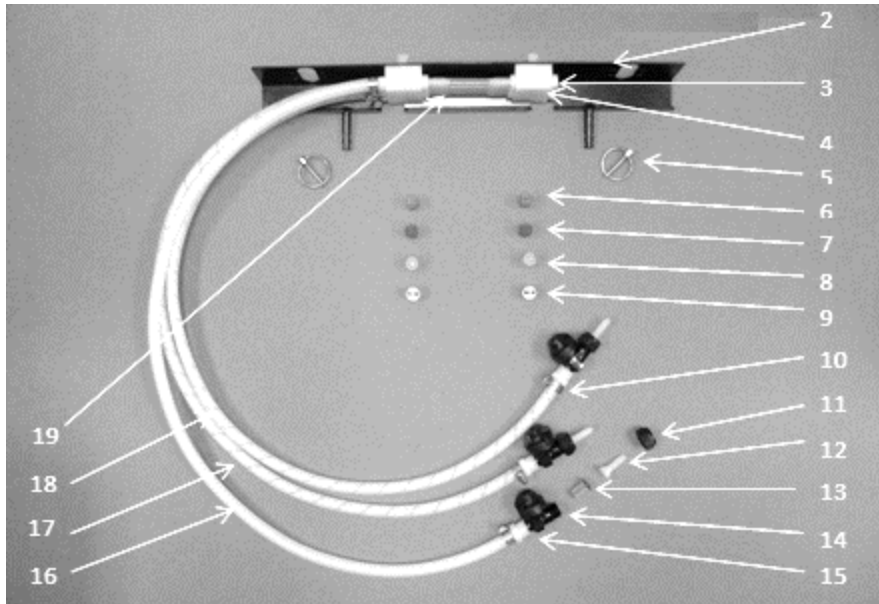
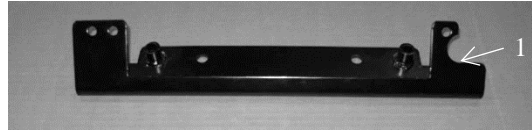

<u>Ref</u>	<u>Description</u>	<u>Part Number</u>	<u>Qty</u>	<u>Ref</u>	<u>Description</u>	<u>Part Number</u>	<u>Qty</u>
1	Holder	001-4435NC	1	11	Cap	004-4723	3
2	Shield	001-4435NSX	1	12	Fitting	003-A1414VB	3
3	Fitting	003-F14	3	13	Strainer	004-1203-100	3
4	Manifold Blk	001-4435NSB	2	14	Check Valve	004-1207VB	3
5	Lynch Pin	008-4576	2	15	Fitting	003-A1414F	3
6	Tip-Red	004-T8003-PT	2	16	Clear Tubing-1/4"	002-9016	3 ft
7	Tip-Brown	004-T80015-PT	2	17	Blue Stripe Tubing	002-9016B	3 ft
8	Tip-Pink	004-T8001-PT	2	18	Green Stripe Tubing	002-9016G	3 ft
9	Tip-Stainless	004-T800067-SS	2	19	EVA-1/4"	002-9006	3 ft
10	Hose Clamp	003-9002	15		Shield Assembly (Ref 1-19)	030-4636B	

Wind Guard Assembly (4ft Baler)

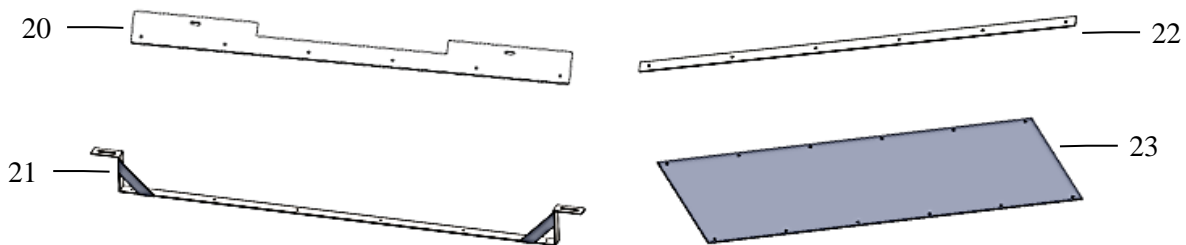

<u>Ref</u>	<u>Description</u>	<u>Part Number</u>	<u>Qty</u>	<u>Ref</u>	<u>Description</u>	<u>Part Number</u>
20	Wind Guard Top Bkt	001-6707MA	1		Wind Guard Kit (Ref 20-23)	030-6707WG4
21	Wind Guard Bottom Bkt	001-6707MC	1			
22	4' Wind Guard Flap	001-6707GM4	1			
23	Backing Plate	001-6707B	2			
					Complete 4636B Assembly (Ref 1-23)	030-4636B

Rear Light / Camera Brackets

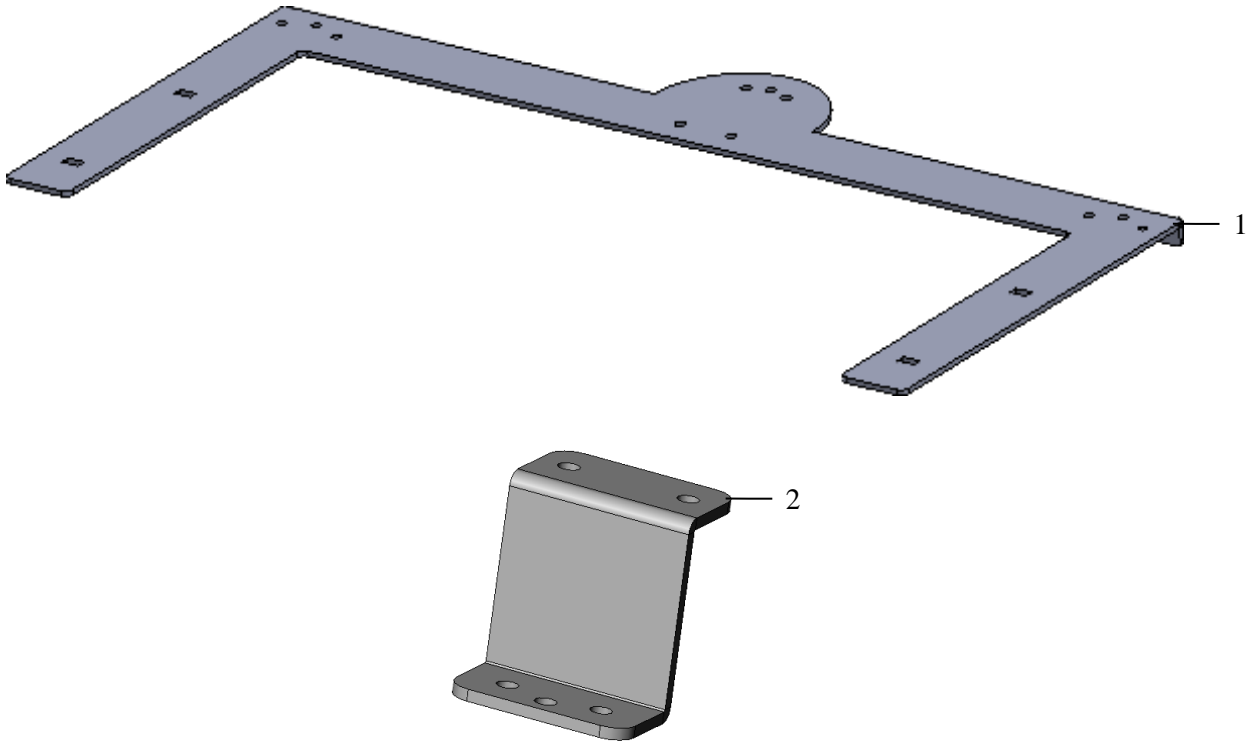

<u>Ref</u>	<u>Description</u>	<u>Part #</u>	<u>Qty</u>
1	Rear Mounting Handrail	001-6707PM	1
2	Camera Mount Bracket	001-6707PMZ	1
NP	Light Extension Harness	006-7303LTX	1

Optional iPad Mini Mounting Kit (030-2014MK)

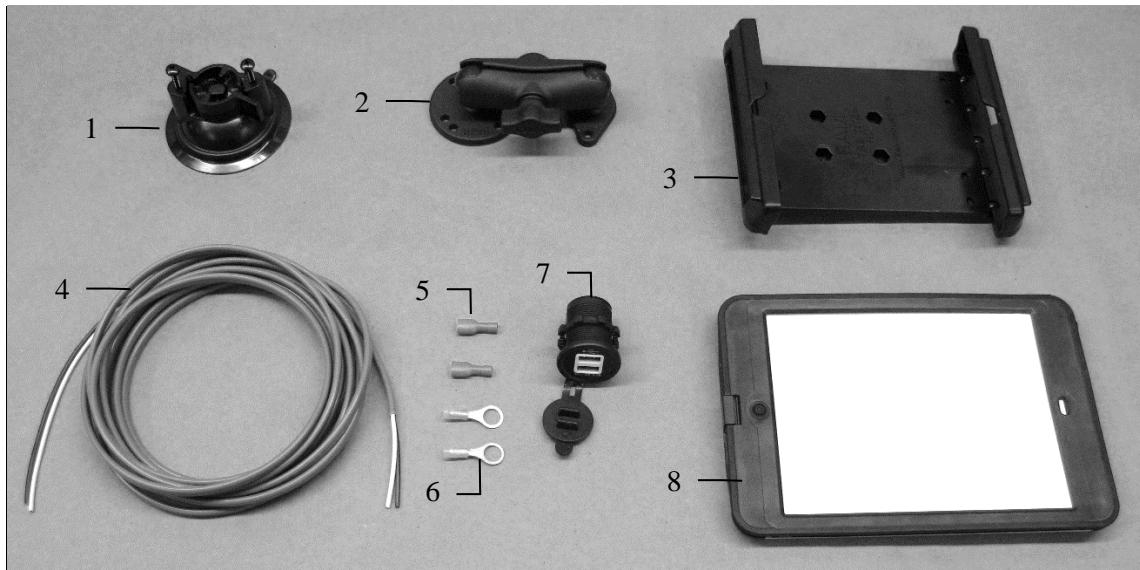

<u>Ref</u>	<u>Description</u>	<u>Part #</u>	<u>Qty</u>
1	Suction cup mount	001-2012SCM	1
2	Ram mount	001-2012H	1
3	iPad Mini® spring load cradle (Mini 4)	001-2012SLC	1
4	16 gauge power wire	006-4723P	1
5	Female spade connector	Hardware	2
6	Eye loop connector	Hardware	2
7	iPad Mini Charger 12V	001-2012P	1
8	iPad Mini 4 case	001-2012C4	1
NP	4 amp fuse	Hardware	1

Mounting Kit Assembly

030-2014MK
(Includes All Parts)

Installation Instructions

1. Identify 12V power source for wires to connect.
 - a. Eye loops included if wiring directly to the battery is desired.
 - b. Test for key power source if preferred to have power to the USB shut off with the key.
2. Once power source is identified, cut wires to desired length.
3. Crimp the two supplied quick connectors onto each the white and black wire.
4. Remove the round locking plastic nut from USB plug before connecting the wires. Black (+) White (-).
5. The wires will then be hooked to the designated terminals on the bottom of the USB plug
6. Drill a 1 1/8" hole in the preferred mounting location. Be sure to clean any sharp edges after drilling.
7. Feed the wires through the mounting hole.
8. If using the round plastic nut to secure plug in place, slide the nut back over the wiring before connecting the wires to powered source.
9. Connect the wires to the identified power source if easier to do so before tightening the plug into place.
10. Tighten plug using either the round plastic nut or mounting plate and two screws, both options supplied.
11. Once connected, hook a USB charging cord into the plug and connect a mobile device/tablet to ensure the plug is operating as you wish (key power working properly if necessary).

NOTE: This plug is not designed to charge two iPads. System damage could occur if this is attempted.
System will charge a mobile phone and iPad simultaneously without problem.

*iPad mini is a trademark of Apple Inc., registered in the U.S. and other countries.

Optional iPad Display Kit (030-4670DK)

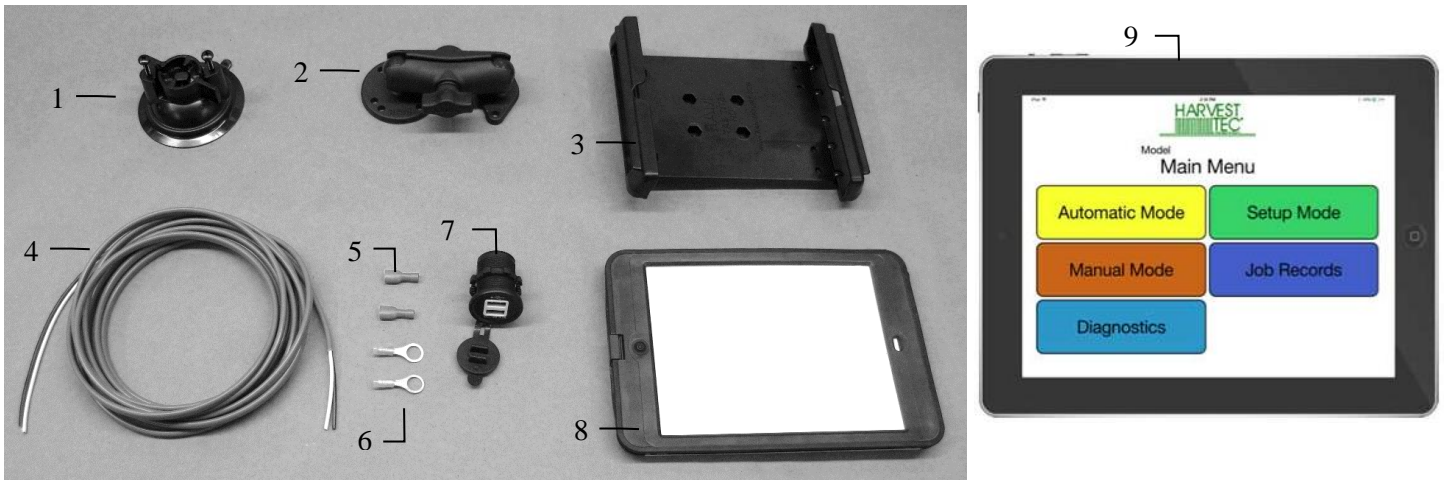

<u>Ref</u>	<u>Description</u>	<u>Part #</u>	<u>Qty</u>	<u>Ref</u>	<u>Description</u>	<u>Part #</u>	<u>Qty</u>
1	Suction cup mount	001-2012SCM	1	7	iPad Mini Charger 12V	001-2012P	1
2	Ram mount	001-2012H	1	8	iPad Mini 4 case	001-2012C4	1
3	iPad Mini® spring load cradle (Mini 4)	001-2012SLC	1	9	iPad Mini 4	006-4670IP	1
4	16 gauge power wire	006-4723P	1	NP	4 amp fuse	Hardware	1
5	Female spade connector	Hardware	2				
6	Eye loop connector	Hardware	2		Mounting Kit Assembly	030-4670DK	
						(Includes All Parts)	

Installation Instructions

1. Identify 12V power source for wires to connect.
 - a. Eye loops included if wiring directly to the battery is desired.
 - b. Test for key power source if preferred to have power to the USB shut off with the key.
2. Once power source is identified, cut wires to desired length.
3. Crimp the two supplied quick connectors onto the white and black wire.
4. Remove the round locking plastic nut from USB plug before connecting the wires. Black (+) White (-).
5. The wires will then be hooked to the designated terminals on the bottom of the USB plug
6. Drill a 1 1/8" hole in the preferred mounting location. Be sure to clean any sharp edges after drilling.
7. Feed the wires through the mounting hole.
8. If using the round plastic nut to secure plug in place, slide the nut back over the wiring before connecting the wires to powered source.
9. Connect the wires to the identified power source if easier to do so before tightening the plug into place.
10. Tighten plug using either the round plastic nut or mounting plate and two screws, both options supplied.
11. Once connected, hook a USB charging cord into the plug and connect a mobile device/tablet to ensure the plug is operating as you wish (key power working properly if necessary).

NOTE: This plug is not designed to charge two iPads. System damage could occur if this is attempted. System will charge a mobile phone and iPad simultaneously without problem.

*iPad mini is a trademark of Apple Inc., registered in the U.S. and other countries.

Optional Rear Light/Camera Brackets

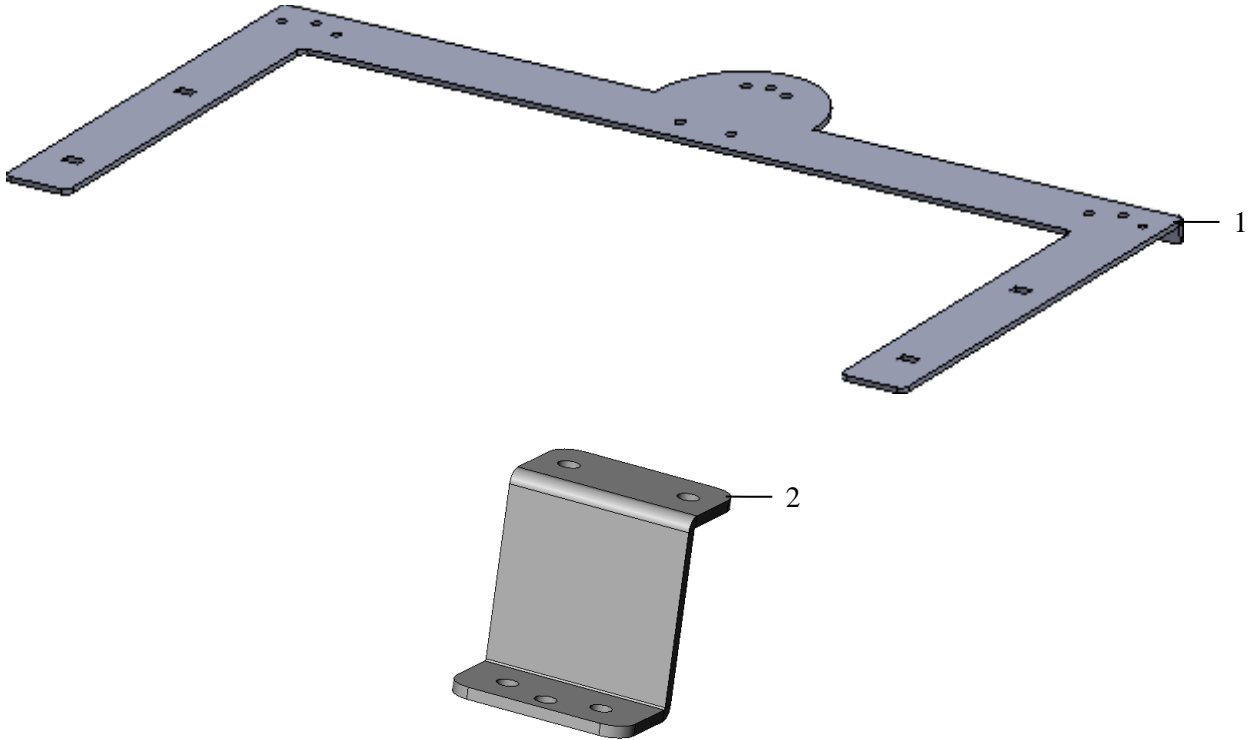

<u>Ref</u>	<u>Description</u>	<u>Part #</u>	<u>Qty</u>
1	Rear Mounting Handrail	001-6707PM	1
2	Camera Mount Bracket	001-6707PMZ	1
NP	Light Extension Harness	006-7303LTX	1

Notes

Harvest Tec Inc. Warranty and Liability Agreement

Harvest Tec, Inc. will repair or replace components that are found to be defective within 12 months from the date of manufacture. Under no circumstances does this warranty cover any components which in the opinion of Harvest Tec, Inc. have been subjected to negligent use, misuse, alteration, accident, or if repairs have been made with parts other than those manufactured and obtainable from Harvest Tec, Inc.

Our obligation under this warranty is limited to repairing or replacing free of charge to the original purchaser any part that in our judgment shows evidence of defective or improper workmanship, provided the part is returned to Harvest Tec, Inc. within 30 days of the failure. If it is determined that a non-Harvest Tec branded hay preservative has been used inside the Harvest Tec applicator system where the failure occurred, then Harvest Tec reserves the right to deny the warranty request at their discretion. Parts must be returned through the selling dealer and distributor, transportation charges prepaid.

This warranty shall not be interpreted to render Harvest Tec, Inc. liable for injury or damages of any kind, direct, consequential, or contingent, to persons or property. Furthermore, this warranty does not extend to loss of crop, losses caused by delays or any expense prospective profits or for any other reason. Harvest Tec, Inc. shall not be liable for any recovery greater in amount than the cost or repair of defects in workmanship.

There are no warranties, either expressed or implied, of merchantability or fitness for particular purpose intended or fitness for any other reason.

This warranty cannot guarantee that existing conditions beyond the control of Harvest Tec, Inc. will not affect our ability to obtain materials or manufacture necessary replacement parts.

Harvest Tec, Inc. reserves the right to make design changes, improve design, or change specifications, at any time without any contingent obligation to purchasers of machines and parts previously sold.

Revised 4/17

HARVEST TEC, INC.
P.O. BOX 63
2821 HARVEY STREET
HUDSON, WI 54016
PHONE: 715-386-9100
1-800-635-7468
FAX: 715-381-1792
Email: info@harvesttec.com