

Owner's Manual

***H₂O Sensor - Model 201LS, 201LSHD
& 200DM
Large Square Baler Precision Moisture Sensing Kit***

HARVEST *Equipment and Products*
 **TEC** *for Quality Hay.™*

P.O. Box 63 • 2821 Harvey Street • Hudson, WI 54016
800-635-7468 • www.harvesttec.com

DECLARATION OF INCORPORATION



MANUFACTURER:

Harvest Tec Inc.
2821 Harvey St.
P.O. Box 63
Hudson, WI 54016, U.S.A.

REPRESENTATIVE ESTABLISHED IN COMMUNITY: Profitable Farming Company
Middle Barlington, Roborough
Winkleigh, Devon, EX19 8AG
ENGLAND

The person above certifies and declares that:

VIRTUAL MACHINE: Equipment mounted on a farm press to monitor moisture.

MODEL: H₂O Sensor-Owners-201LS, 201LSHD-19-Imp&Metric

BRAND: Harvest Tec

SERIAL NUMBER:

This Harvest Tec moisture system meets the Directive 2006/42/EC of the European Parliament and the Council of 17 May 2006 and other applicable European Directives including Directive 2014/53/EU on the Radio Equipment Directive and 2014/30/EU.

The Harvest Tec moisture system will be turned on after being installed on a farm press which has been declared in conformity with the Machinery Directive.

Person in the community authorized to provide information on the partly completed machinery and making this statement:

Richard Snell, President, Profitable Farming Company
Signed on May 21, 2011: Middle Barlington, Roborough
Winkleigh, Devon, EX19 8AG
ENGLAND

H₂O Moisture Owner's Manual Table of Contents

	<u>Page</u>
Introduction	3
Installation of Star Wheels	4-7
AGCO Balers – Non-UHD Models	4
AGCO Balers – UHD Models	4
Claas Balers	5
CNH BB & LB Balers	5
John Deere L330-L341 Balers	6
Balers Not Listed	7
Alternative Star Wheel Mounting Location	7
Control Box Installation	8
End of Bale Sensor Installation - 200FCA (Optional)	8
Dye Marker Installation - 200DM (Optional)	9
Wiring Diagram	10
Downloading H₂O App	11
Screen Definitions	11
Operation	12-13
Reading Moisture	12
Moisture Range	12
Dye Marker System	13
Dye Sprayer Override	13
H₂O Firmware Update through App	14
Pin Outs	15
Parts Breakdown	16-18
Star Wheels	16
Control Box & Harnesses	17
Fixed Chamber End of Bale Sensor Kit	17
H ₂ O Dye Marker	18
Warranty Statement	19

Introduction

Congratulations and thank you for purchasing a Harvest Tec H₂O Moisture Sensing Kit Model 201LS system. Please read this manual carefully to ensure correct steps are taken to attach the system to the baler. This system is designed to read moisture at levels of 5-60%.

Requirements

The app will support operation of the current operating system and one previous version for both Apple and Android devices.

*** It is recommended for proper communication that the original phone/tablet power cable is used. Many lower cost power cables do not meet requirements to properly charge and communicate to the Harvest Tec H₂O module.*

Tools Needed

SAE wrench set	Hammer	Drill bit set
Standard screw driver	Measuring tape	Center punch
Side cutter	SAE socket set	

Installation of Star Wheels

AGCO Balers - Non-UHD Models

The star wheels are to be mounted on top of the baler, just behind the knotters and under the walkway on both sides. The notch and holes for the star wheel are precut. If the star wheels are cutting the twine the sensors and notch must be moved out an additional 1/2" (13mm).

Place the spacer plate (001-6707E) over the precut holes. Attach with 5/16" x 1/2" Allen head bolts and internal star washers from inside the bale chamber. Center the star wheels over the top of the spacer plate, place the twine diverters on top of the star wheel and attach with 5/16 x 2-1/4" hex bolt and lock washers.

Remaining two holes per star wheel attach with 5/16" x 2 1/4" hex bolt, lock washer, and one 5/16" thick flat washers per bolt. Verify that star wheels align with bale chamber before tightening down all hardware. The twine guard containing the bale rate sensors will be placed on the right side of the baler.

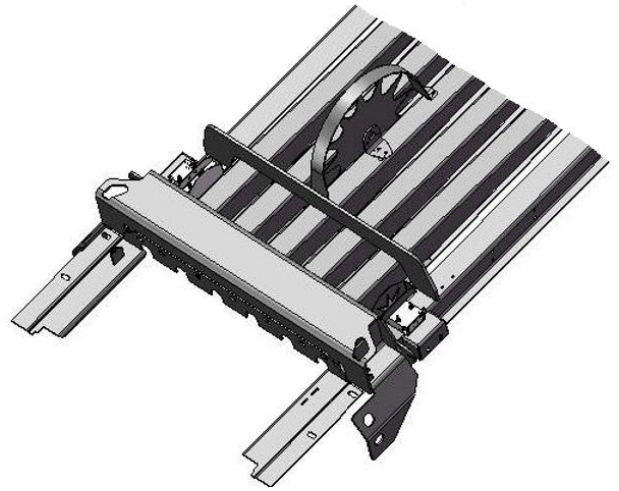

AGCO Balers - UHD Models

The star wheels are to be mounted on top of the baler, just behind the knotters and under the walkway on both sides. The holes for the star wheel are precut. Remove the plate on top of the catwalk covering the triangle shaped access cutout. Place star wheel over the predrilled holes on both sides of the bale chamber, (right).

Secure the star wheels with 5/16" x 3-1/4" BHCS (x2 each side) from the bottom side and are secured with 5/16" lock washer and nuts. Blocks are dropped down on the bolts and secured in place with the star wheel twine guards (001-4645H, 001-4644H). The twine guard containing the bale rate sensors will be placed on the right side of the baler.

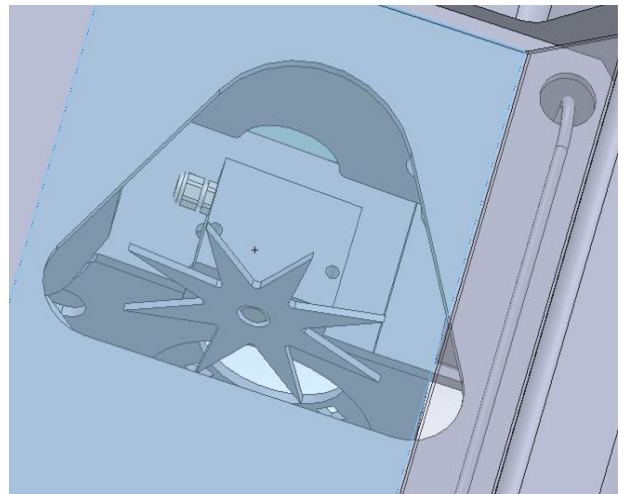

Installation of Star Wheels (continued)

Claas Balers

Use the picture below as a guide for drilling the mounting holes for the star wheels. The star wheels are to be mounted on the side of the bale chamber, between the top and middle channel. Measure 10" back from the hinge between the top and middle channel. Cut 1" x 9" (25mm x 23cm) slot for the star wheel. Make sure the wheel is square.

Mark the location of the two 5/16" (8mm) holes for the star wheel base. After drilling the holes, insert the 5/16" x 3 1/4" allen head bolts through the chute and use nuts to hold the bolts in place. Place the star wheel block over the nuts and install the prox sensor holder (001-4644H) on the star wheel located on the right side of the baler. Note: Thicker side of block goes to baler side.

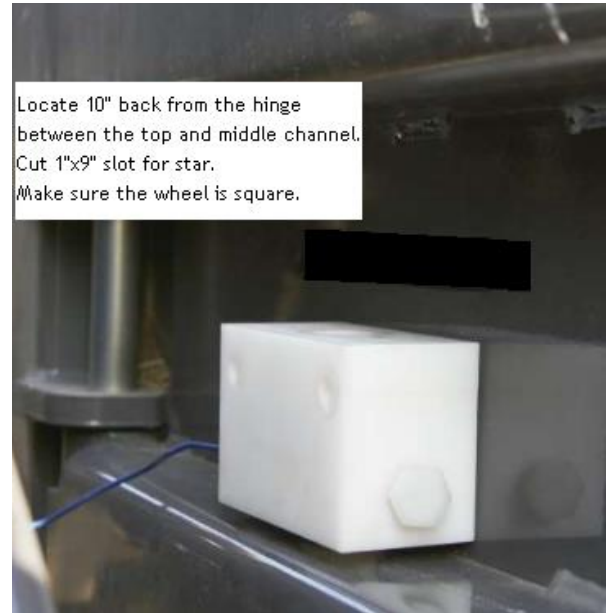

CNH BB & LB Balers

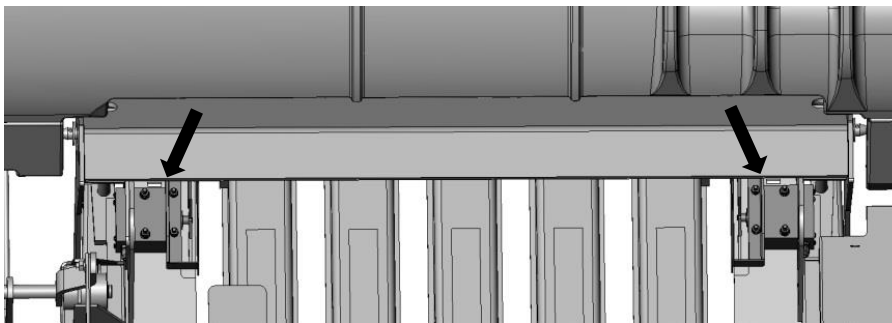

Use the pictures above a guide to mounting the star wheels. Locate the two star wheel moisture sensors (030-4641) and twine diverters (001-4644 & 001-4645). Directly behind the knotters, locate the four predrilled holes per side shown at the arrows. This location is also beneath the lift points on top of the baler.

Install the eight (four per side) 5/16" x 3" Allen head cap screws. Make sure the Allen heads are in the bale chamber. Secure using eight 5/16" hex nuts (right). Install the star wheels below the lift points on the baler. Install the twine diverters over the star wheel sensor. The twine diverter with two extra sensors will be installed on the right star wheel.

Secure the star wheels and twine diverters with four 5/16" hex nuts, lock washers, and two flat washers.

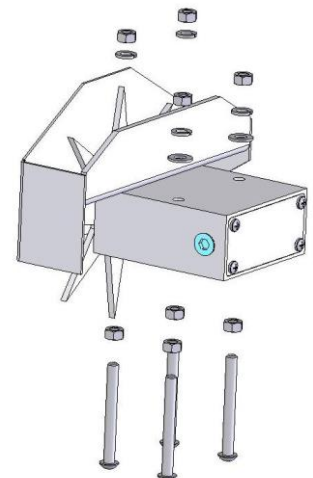

Installation of Star Wheels (continued)

John Deere L330-L341 Balers

Remove any material from the bale chute. The star wheels are to be mounted on the transition bracket on both sides of the bale chute located after knotters shown above. Holes have been installed at the factory, however you need to remove bracket and cut 3/4" (19mm) off the bracket as indicated below to allow proper spacing for star wheel assembly.

Once complete, touch up with spray paint to prevent rusting and place the carriage bolts that mount the transition bracket back in original bracket mounting holes (A) before mounting star wheel assembly (C). Insert the 5/16" x 3 1/4" Allen head bolts up through the transition bracket and use nuts to hold the bolts in place (B). Place the star wheel block over the nuts. Place twine guard on top of star wheel (D), the guard containing bale rate sensors will be placed on the right side.

Note: Thicker part of star wheel block should be on baler side.

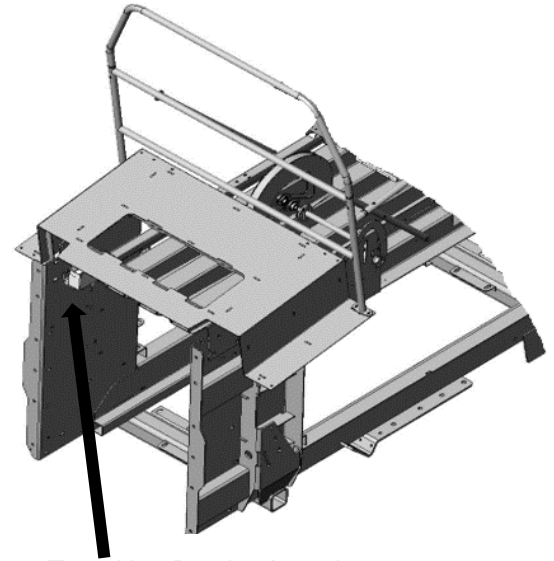

Transition Bracket Location

Cut 3/4" Off Bracket

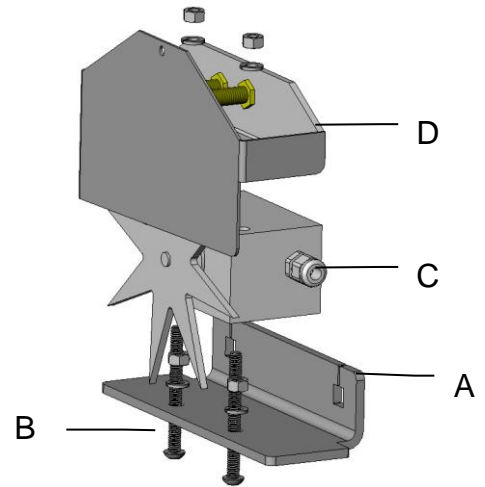
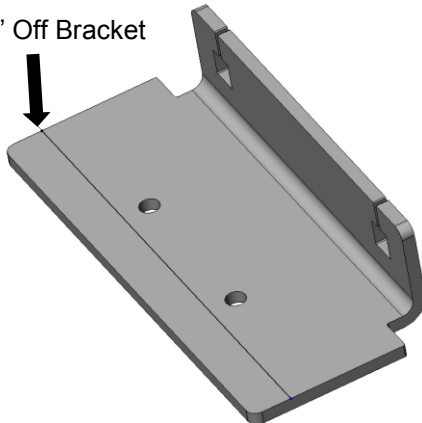

Star wheel assembly

Installation of Star Wheels (continued)

Balers Not Listed

The star wheels are mounted under the walkway on top of the baler behind the knotters. Remove the bale from the chute and tip the walkway up. Locate the star wheel template on the outside corner angles of the bale chute on the left and right side of the baler.

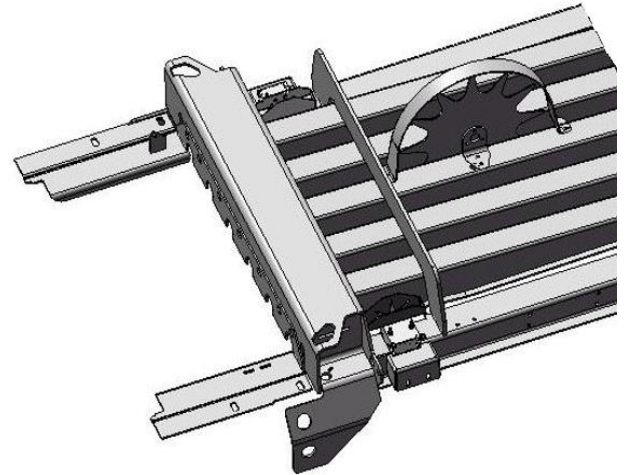

The center of the wheel shaft will be approximately 5-1/2" (13cm) in front of the walkway support or about halfway between the walkway support and the cross frame almost directly in front of it. The notch will start just in front of the walkway support.

Two parts of the baler frame will have to be trimmed off on both sides to mount each star wheel. The first is the outside corner angles of the chute. Use the template to mark the location of the star wheel notch as well as the location of the four holes for the star wheel base. The notch will be 5/8" by 9" (16mm x 23cm) long and will help keep the wheel away from the twine. Spray the ground off areas with touch up paint to prevent rusting.

The second portion of the baler to trim off is the end of the gusset that may interfere with the star wheel's plastic base support. Center the star wheel in the slots that was just notched and check for interference with the gusset.

Drill 5/16" (8mm) holes for the star wheel block. Insert the 5/16" x 3" bolts up through the chute and use nuts to hold the bolts in place. Place the star wheel block over the nuts and install the twine guards using the two inner holes of the star wheel block. The twine guard containing the bale rate sensors will be placed on the right side of the baler.

Alternative Star Wheel Mounting Location

If steam is being added to the bales prior to the crop entering the chamber, positioning the star wheels at the rear of the bale chamber will allow the star wheels to accurately read the moisture.



Two parts of the baler frame will have to be trimmed off on both sides to mount each star wheel. The first is the outside corner angles of the chute. Use the template to mark the location of the star wheel notch as well as the location of the four holes for the star wheel base. The notch will be 5/8" by 9" (16mm x 23cm) long and will help keep the wheel away from the twine. Spray the ground off areas with touch up paint to prevent rusting.

The second portion of the baler to trim off is the end of the gusset that may interfere with the star wheel's plastic base support. Center the star wheel in the slots that was just notched and check for interference with the gusset.

Drill 5/16" (8mm) holes for the star wheel block. Insert the 5/16" x 3" bolts up through the chute and use nuts to hold the bolts in place. Place the star wheel block over the nuts and install the twine guards using the two inner holes of the star wheel block. The twine guard containing the bale rate sensors will be placed on the right side of the baler.

Control Box Installation

Locate a safe location in the cab of the tractor to place the control box (006-2473SB). Recommended location is as close to the tablet or phone being used to control the system.

Connect the Power Harness (006-2470P) and the Baler Power Communication Harness (006-2470LS).

The control box (006-2473SB) is equipped with a green light to indicate both power and connection.

Plug the tablet/phone cord into the communication port (closest to light) and indicated by:

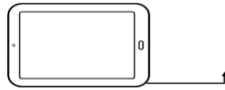

006-2473SB

Slow Blink – System has power but not connected to phone or tablet.

Solid Green – Device is connected.

*** It is recommended for proper communication that the original phone/tablet power cable is used. Many lower cost power cables do not meet requirements to properly charge and communicate to the Harvest Tec H2O module.*

End of Bale Sensor Installation – 200FCA (Optional)

The end of bale sensor is used to determine when the baler needle arm moves. With this information the system is able to show the average moisture of the previous bale. Part number for kit is 200FCA.

Mount the 006-7400 sensor to the mounting bracket 001-4648RB as shown below. Mount the assembly on the right side of the baler chamber. The face of the sensor needs to be parallel to the arm attached to the needles.

*Note: The bracket may need to be slightly bent for the proper positioning.

Mark and drill two 3/8" (10mm) holes. Install the sensor using two 5/16" x 1" allen head bolts, locks, and nuts. The end of the sensor needs to be no greater than 1/4" (7mm) away from the needle arm. Tighten nuts on sensor after adjustment.

The harness will need to be routed toward the harness at the tongue of the baler. Secure with cable ties and take care to avoid pinch points. The harness extension (006-7400EXT) may need to be used.

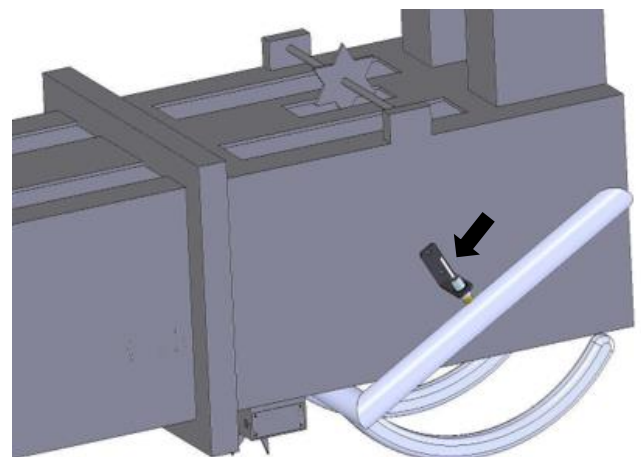
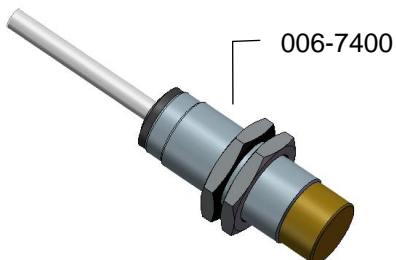
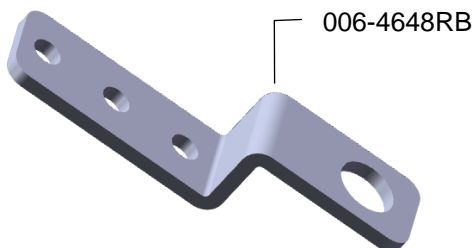

Dye Marker Installation – 200DM (Optional)

Locate the dye marking kit tank and pump assembly (005-9015). Identify a suitable mounting location for the tank away from moving parts and hydraulic lines on the baler. Be sure to mount the tank within 10' of the connection on the Baler Pwr/Comm Harness (006-2470SS), wiring details in the wiring diagram.

Note: The mounting location will potentially be different for the tank on each baler model. Due to various baler designs and modifications, Harvest Tec does not offer a specific mounting location for each baler model.

Once a mounting location has been identified, mount the tank vertically as shown (right) with the tank lid on the top using the included hardware.

Next locate the dye marking spray assemblies shown (below).



***Small square and Large square balers must use the brass tip (004-TX-5)**

Nozzle straps should be placed directly below the star wheels so spray will be applied on the side of the bale.

Mount the second tip assembly on the left side of the baler in a similar position (below).

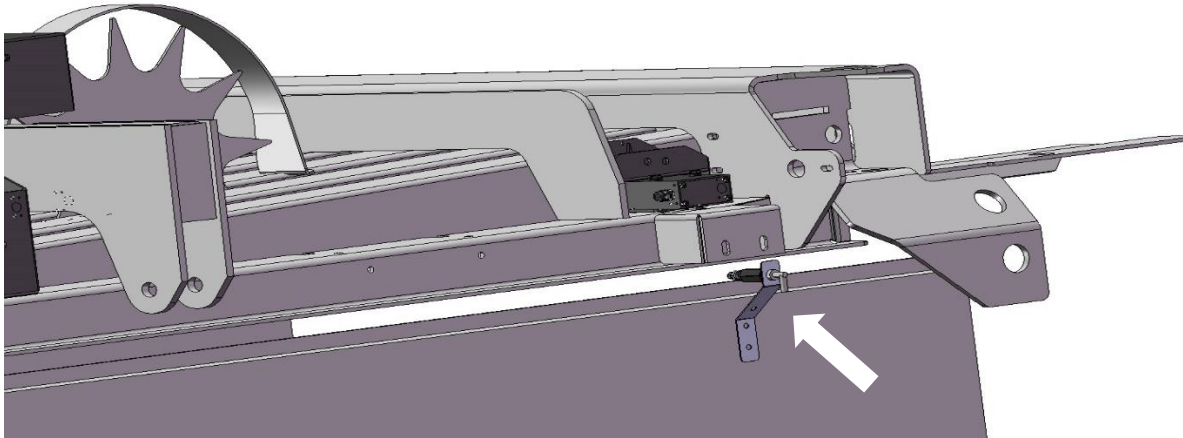

Alternative Dye Marking Nozzle Mounting Location



When using the alternative star wheel mounting location at the end of the bale chamber, the dye marking nozzles can be located at the rear of the bale chamber as shown (left).

Routing the Hose

Using the supplied 1/4" hose (002-9006) connect to the pump and secure with the hose clamps (003-9002). Route the hose to each tip assembly by using the 1/4" barbed tee (003-T1414) to go to each side of the baler. Be sure to avoid moving parts.

Wiring Diagram

1. Connect the power harness (006-2470P) to the tractor convenience outlet keyed power switch using the red wire with fuse to the positive side and the black wire to the negative.
 - a. Any modifications of the power harness will void the warranty. Contact Harvest Tec before modifications are made.
2. The power harness (006-2470P) will mount on the tractor connected to the control box (006-2473SB) with the 12 pin male deutsch connection and the opposite end down to the draw bar.
3. Connect the Baler Pwr/Comm Harness (006-2470SB) to the power harness (006-2470P).
4. Route the Pwr/Comm Harness (006-2470LS) on the baler to each moisture sensor on both sides of bale chamber, sensors are pn 030-4641.
5. Connect the USB charging/comm cord for the phone or tablet being used, to that device and the 201 control box (006-2473SB).
6. When using a Dye Marker the End of Bale Sensor kit will need to be added to the system in order to see when needle arm cycles. Part number (200FCA). Connect the sensor to the End of Bale (EOB) connection on the Baler Pwr/Comm Harness (006-2470LS).
7. When using the optional Dye Marker (200DM) connect 4 pin round end of the H2O harness (006-2470C) to the Dye Marker (DM) connection on the (006-2470LS) harness. Then connect the two straight spade connections with only the white wire to the push switch (006-2850). The remaining two connections with 90 degree female spades will connect to the pump.

System wiring diagram

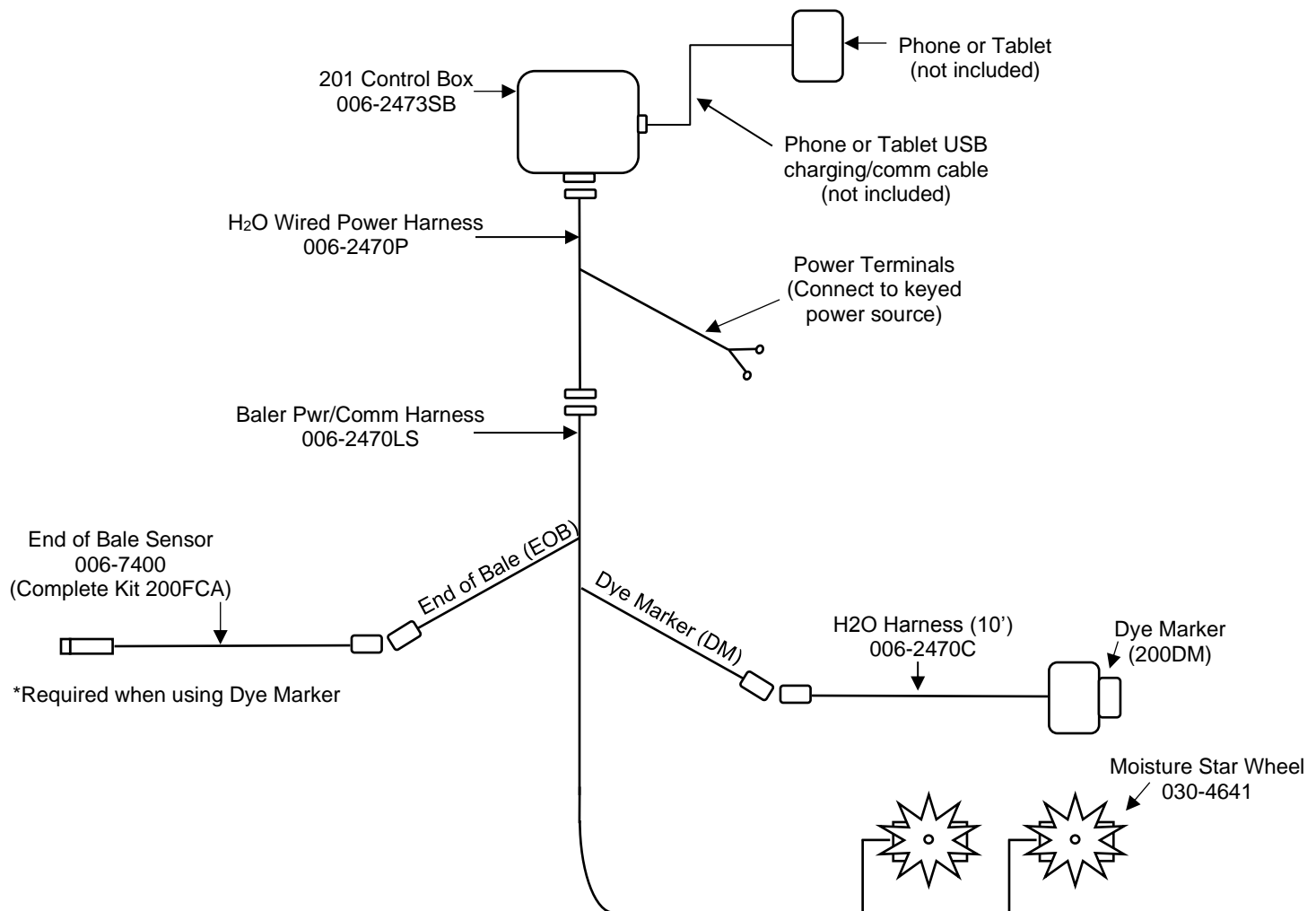

*If needed an optional 8' Pwr/Comm harness extension is available (not included), part number 006-2470BL.

Downloading H₂O App

The H₂O App is available on any Apple or Android device running with the current operating system software and one previous version. Download the app by searching for H₂O Sensor. App icon shown right.



Screen Definitions

Main Screen

Brightness Adjustment – Tap to switch between day and night time brightness

Current Moisture Reading – Information will display once hay enters the bale chamber

Current App Version (example)

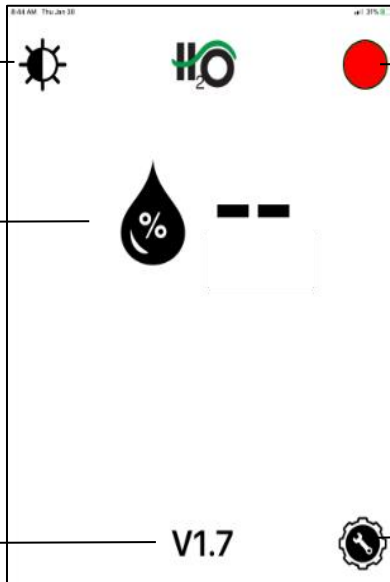

Connection Signal - When connection is made with the control box light will turn Green

Red – Not Connected
Green - Connected

Settings Tab – Select to switch to Settings Screen

Settings Screen

Dye Marker System

Home Tab – Select to change to Home Screen

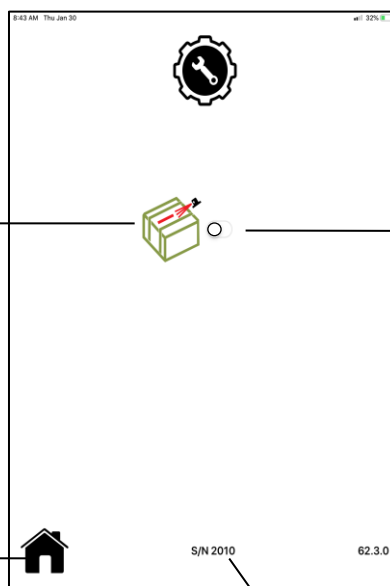

On / Off Slide – Slide to the right to turn On Setting. The bar will turn red or green (dependent on device)

App Version

Serial Number of System

Operation

After installation of the H₂O app, turn the system on by turning the key in the tractor on. When the connection is made the green light on the control box will illuminate.

Reading Moisture

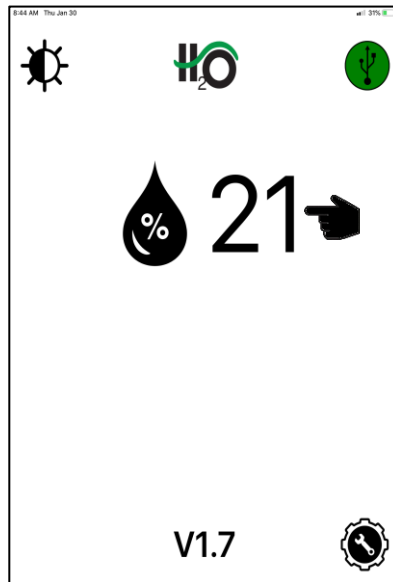

When hay begins to enter the bale chamber,
current moisture will be displayed

Moisture Range 5-60%

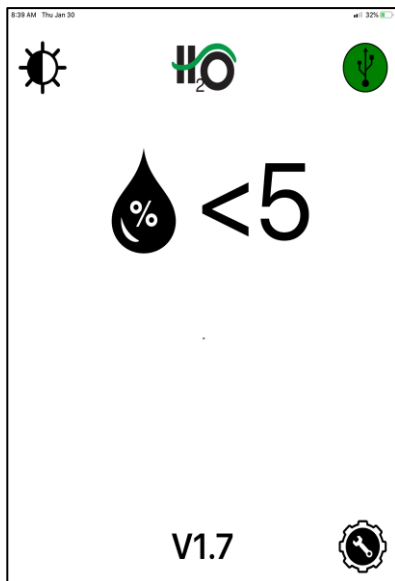

If the moisture being read is Less Than 5% the
reading will appear as shown above

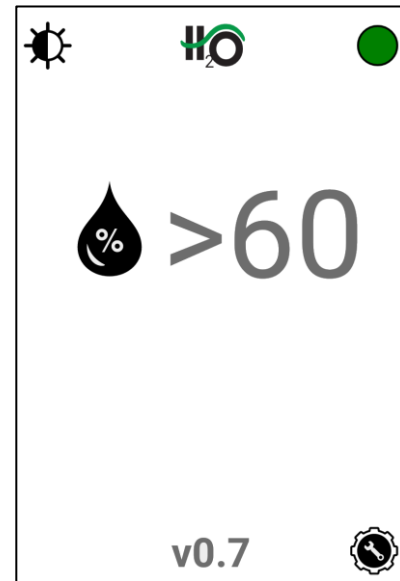

If the moisture being read is Greater Than 60%
the reading will appear as shown above

Operation (continued)

Dye Marker System

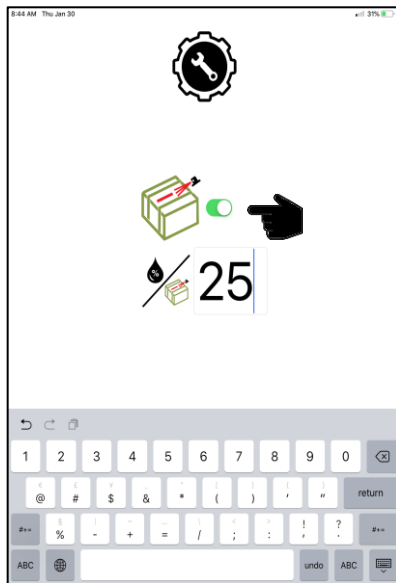

When using the dye marker turn on the setting as shown and select the desired moisture to mark a bale.
*Bales at or above this moisture level will be marked.

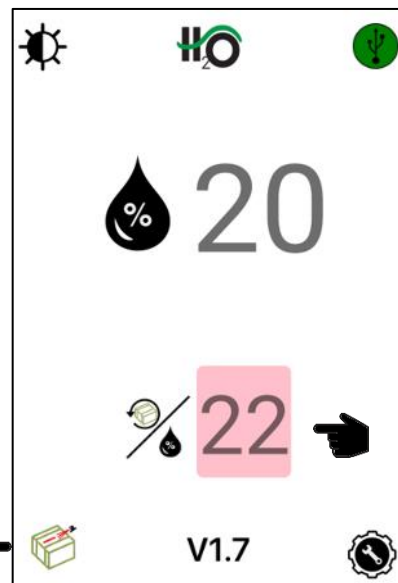

Dye Marker icon will now appear on the home screen. The last bale moisture will be highlighted in red and the bale will be marked at or above the set moisture.

Dye Marker Notes

- When the Dye Marker is activated by the moisture setting it will spray 3 seconds once per End of Bale (EOB) cycle. After an EOB signal the dye marker is then reset to be able to spray again for 3 seconds once on the next bale.
- A full tank of dye is estimated to mark 50-60 bales.

Dye Marker Override

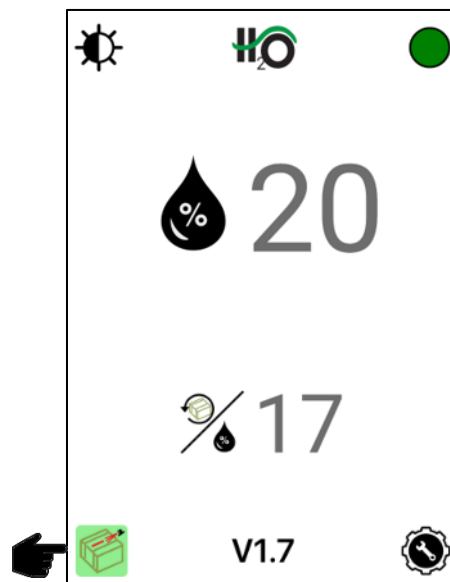

If you want to mark a bale for any reason, press the bale icon to activate the sprayer. The icon will turn green.
*When the manual override is used, the last bale moisture will not highlight in red.

The manual spray function can be used on a bale as many times as preferred in 3 second intervals.

H₂O Firmware Update through App

When there is an update available for the H₂O system the following information will appear and the steps listed will need to be followed.

Once an operator downloads the app update (internet connection required) the “update available” symbol will appear along with the version number of the available update once connected to the system.

At this point the system can run without updating if the operator chooses. The icon will simply remain on the screen.

Once the operator decides to perform the software update, they will press the version number or upload arrow to begin. Internet connection is not required to perform the update to the module once the app is downloaded

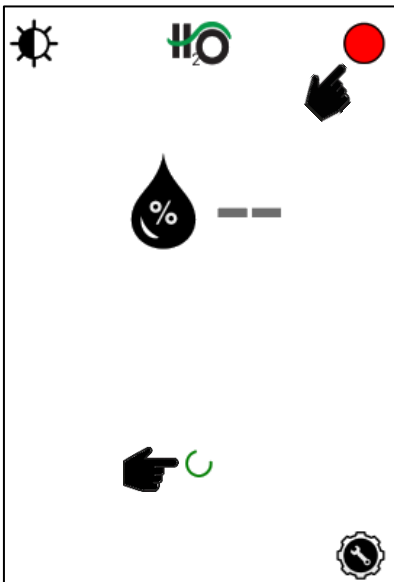

Once the update is initiated, the system will enter update mode

The status light will turn red

A green loading symbol will begin to circulate on the screen

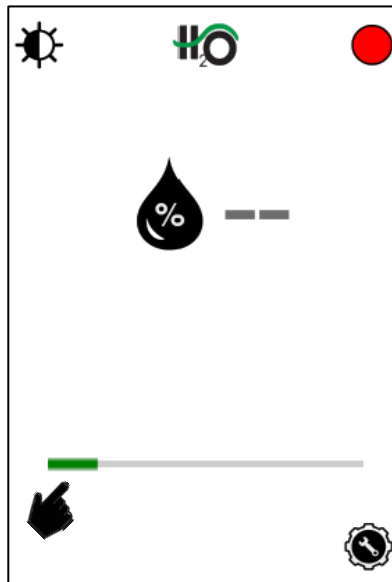

A status bar with then appear to show the update progress

This can take 3-5 minutes to load software

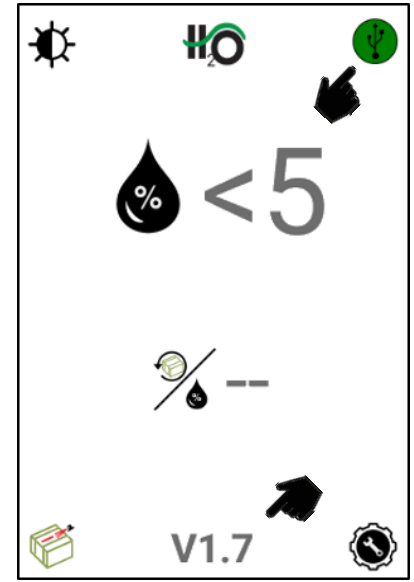

Once the status bar load completely, the system will boot back up

The status light will again turn green

The updated version number will be shown at the bottom of the screen

Pin Outs

H2O Wired Moisture Control 006-2473SB

Pin 1	Red	Module Power
Pin 2	Red/Black	EOB +
Pin 3	Black	EOB -
Pin 4	Grey	Left Moisture Sensor
Pin 5	Brown	Right Moisture Sensor
Pin 6	Purple	EOB Signal
Pin 7	Yellow	CAN +
Pin 8	Green	CAN -
Pin 9	Red/White	Dye Marker 12V +
Pin 10	Black/White	Dye Marker 12V -
Pin 11	Blue	Dye Marker Prime
Pin 12	Black	Ground

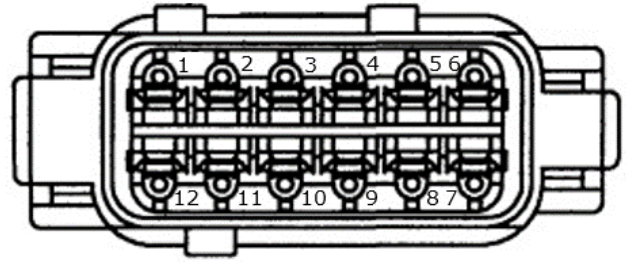

H2O Wired Power Harness 006-2470P

Pin 1	Red	Module Power
Pin 2	Red/Black	EOB +
Pin 3	Black	EOB -
Pin 4	Grey	Left Moisture Sensor
Pin 5	Brown	Right Moisture Sensor
Pin 6	Purple	EOB Signal
Pin 7	Yellow	Not Used
Pin 8	Green	Not Used
Pin 9	Red/White	Dye Marker 12V +
Pin 10	Black/White	Dye Marker 12V -
Pin 11	Blue	Dye Marker Prime
Pin 12	Black	Ground

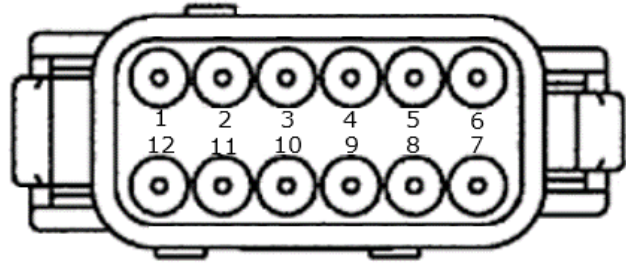

Baler Communication Harness 006-2470LS

Pin 1	Red/Black	EOB +
Pin 2	Black	EOB -
Pin 3	Purple	Left Moisture Sensor
Pin 4	Grey	Right Moisture Sensor
Pin 5	Brown	EOB Signal
Pin 6	Red/White	Dye Marker 12V +
Pin 7	Black/White	Dye Marker 12V -
Pin 8	Blue	Dye Marker Prime

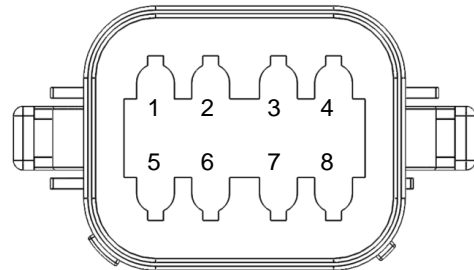

End of Bale Sensor (EOB) 006-2471B

Pin 1	Brown	EOB +
Pin 2	Blue	EOB -
Pin 3	N/A	Not Used
Pin 4	Black	EOB Signal

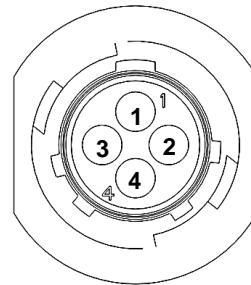

Dye Marker H2O Harness 006-2470C

Pin 1	Red	DS +
Pin 2	Black	DS -
Pin 3	White	DS Prime
Pin 4	N/A	Not Used

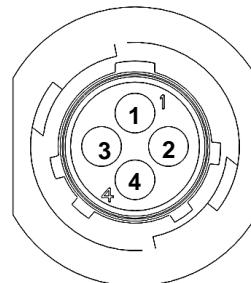

Star Wheels

Large Square Balers

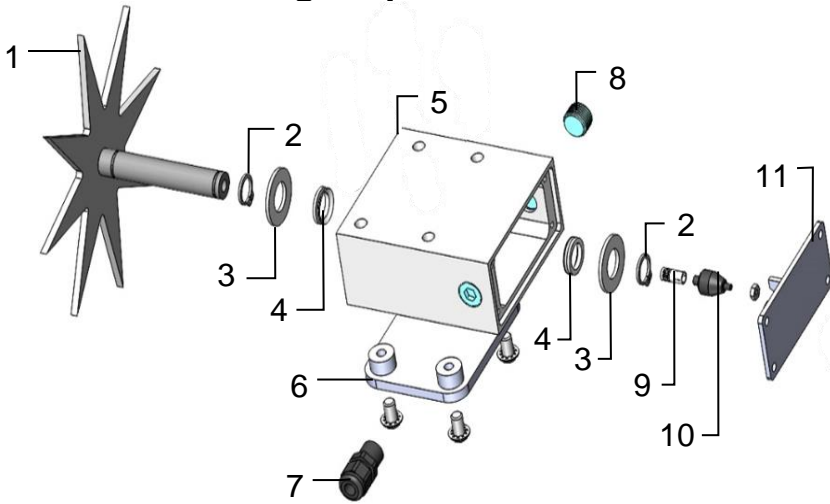

Ref	Description	Part#	Qty
1	Star wheel sensor	030-4641C	1
2	Snap ring (per side)	006-4641K	2
3	Washer (per side)	w/006-4641K	2
4	Dust seal (per side)	w/006-4641K	2
5	Star wheel block	006-4641A	1
6	Star wheel spacer	001-6707E	1
7	Wiring grommet	008-0821A	1
8	Plug fitting	003-F38	2
9	Swivel insert	w/ Ref # 1	2
10	Electronic swivel	006-4642A	2
11	Block cover	006-4641B	2
	*Optional Twine guard-left	001-4645	1
	*Optional Twine guard-right	001-4644	1

Star wheel Assembly 030-4641
(Ref 1-11)

JD, Vicon, Kuhn, Krone, Claas 3200-3400

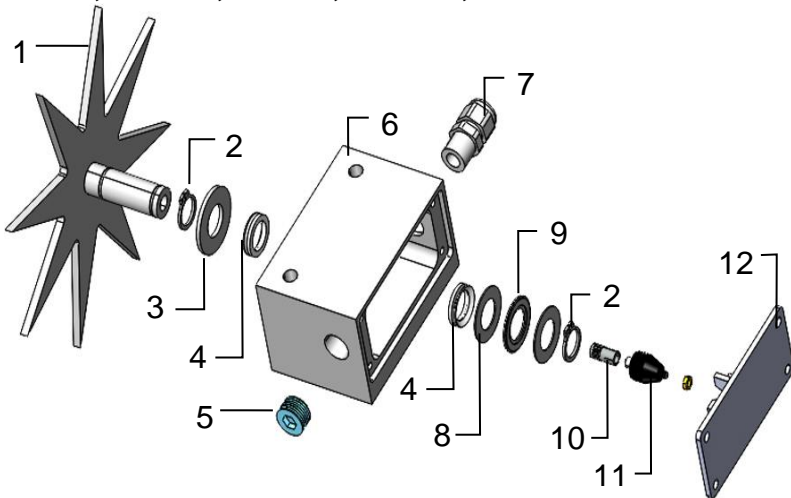

Ref	Description	Part#	Qty
1	Star wheel	006-4641E	1
2	Snap ring (per side)	w/006-4642K	2
3	Washer 1-1/4"	Hardware	1
4	Dust seal (per side)	w/006-4642K	1
5	Plug fitting	003-F38	1
6	Star wheel block	006-4641D	1
7	Wiring grommet	008-0821A	1
8	Washer 5/8"	w/006-4642K	2
9	Bearing	w/006-4642K	1
10	Insert w/ Ref #1	006-4642B	1
11	Swivel	006-4642A	1
12	Block Cover	006-4641B	1
	*Optional Twine guard-left	001-4644	1
	*Optional Twine guard-right	001-4645	1

Star Wheel Assembly 030-4642
(Ref 1-12)

AGCO UHD Baler

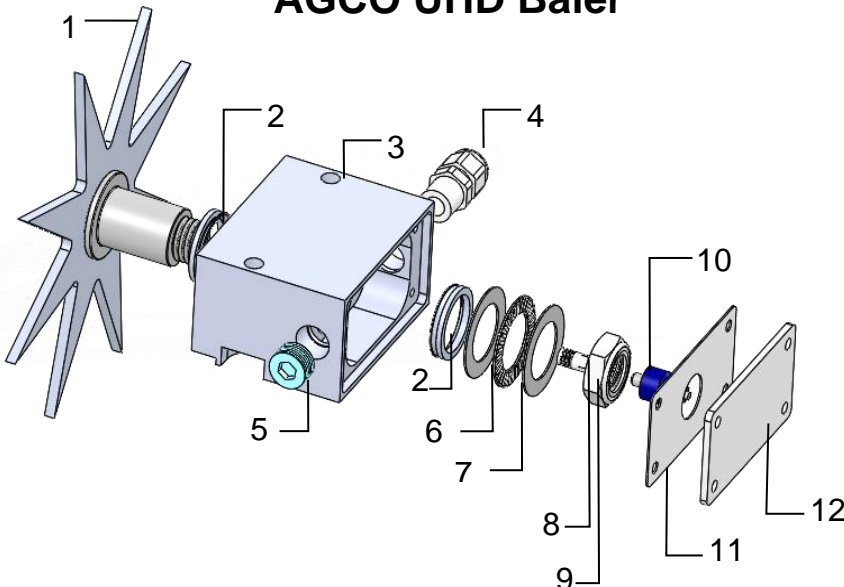

Ref	Description	Part#	Qty
1	Univ Star Wheel	006-4641S	1
2	Dust Seal	006-4641DSL	2
3	Univ Star Block	006-4641Q	1
4	3/8" NPT Cable Grip	008-0821A	1
5	3/8" NPT Plug	003-F38	1
6	Thrust Washer	006-4641TA	2
7	Thrust Bearing	006-4641TB	1
8	Swivel Insert	006-4642B	1
9	3/4" Short Nut	006-4641U	1
10	Rotary Swivel	006-4642A	1
11	Cover Gasket	006-4641RG	1
12	Univ Block Cover	006-4641R	1
	*Optional Twine guard-left	001-4644	1
	*Optional Twine guard-right	001-4645	1

Star Wheel Assembly 030-4641U
(Ref 1-12)

**Can be added if twine excessively makes contact with star wheels.*

Control Box & Harnesses

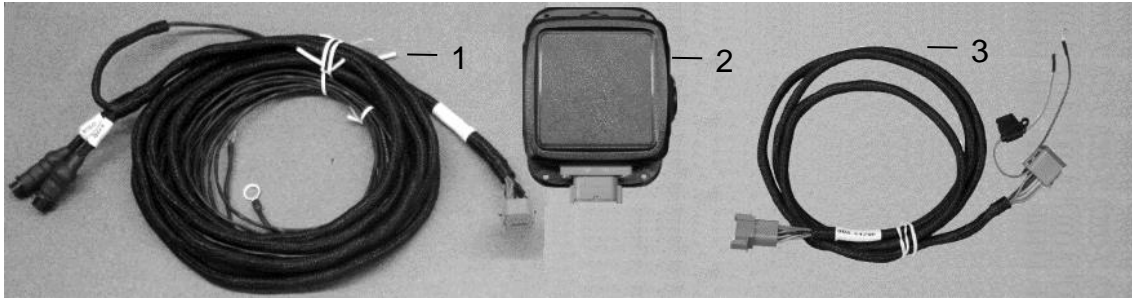

<u>Ref</u>	<u>Description</u>	<u>Part #</u>	<u>Qty</u>
1	Baler Pwr/Comm Harness	006-2470LS	1
2	201 Series Control Box	006-2473SB	1
3	Tractor Power Harness	006-2470P	1
	Optional 8' power/comm harness extension	006-2470BL2	

Fixed Chamber End of Bale Sensor Kit

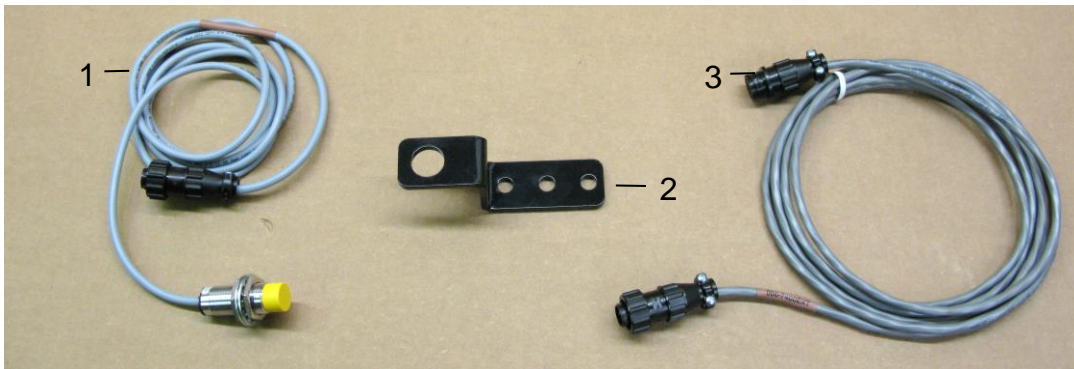

<u>Ref</u>	<u>Description</u>	<u>Part #</u>	<u>Qty</u>	<u>Ref</u>	<u>Description</u>	<u>Part #</u>	<u>Qty</u>
1	End of Bale Sensor	006-7400	1	3	EOB Extension Complete Kit	006-7400EXT 200FCA	1
2	End of Bale Bracket	001-4648RB	1				

H₂O Dye Marker

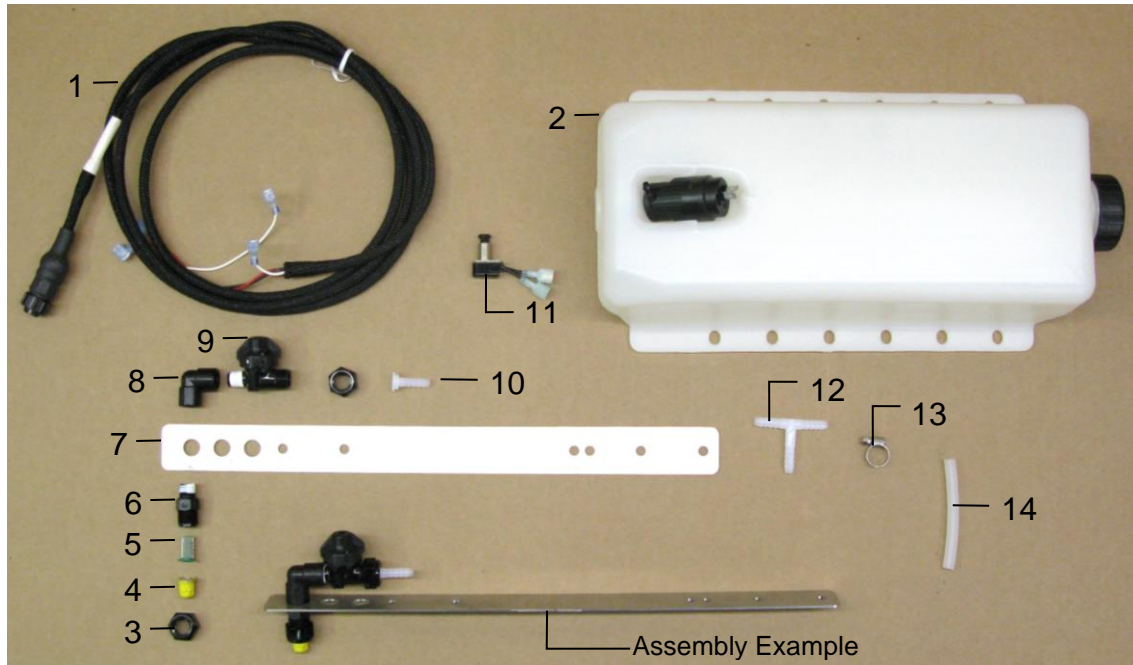

<u>Ref</u>	<u>Description</u>	<u>Part #</u>	<u>Qty</u>	<u>Ref</u>	<u>Description</u>	<u>Part #</u>	<u>Qty</u>
1	H2O Harness (10')	006-2470C	1	8	1/4" Street Elbow	003-SE14F	2
2	Tank & Pump	005-9015	1	9	Check Valve	007-1207VB	2
3	Nozzle Cap	004-4723	4	10	1/4" Straight Fitting	003-A1414VB	2
4	Tip - Brass	004-TX-5	2	11	Push Switch	006-2850	1
5	Tip Strainer (Green)	004-1203-100	2	12	1/4" All Barb Tee	003-T1414	1
6	Nozzle Body	004-4722	2	13	Mini Hose Clamp	003-9002	6
7	Nozzle Holder	001-4215	2	14	1/4" Hose	002-9006	40
				NP	Red Dye	009-0800	1
				NP	End of Bale Sensor Kit	200FCA	1
					Complete Assembly	030-200DM	

Harvest Tec Inc. Warranty and Liability Agreement

Harvest Tec, Inc. will repair or replace components that are found to be defective within 12 months from the date of manufacture. Under no circumstances does this warranty cover any components which in the opinion of Harvest Tec, Inc. have been subjected to negligent use, misuse, alteration, accident, or if repairs have been made with parts other than those manufactured and obtainable from Harvest Tec, Inc.

Our obligation under this warranty is limited to repairing or replacing free of charge to the original purchaser any part that in our judgment shows evidence of defective or improper workmanship, provided the part is returned to Harvest Tec, Inc. within 30 days of the failure. If it is determined that a non-Harvest Tec branded hay preservative has been used inside the Harvest Tec applicator system where the failure occurred, then Harvest Tec reserves the right to deny the warranty request at their discretion. Parts must be returned through the selling dealer and distributor, transportation charges prepaid.

This warranty shall not be interpreted to render Harvest Tec, Inc. liable for injury or damages of any kind, direct, consequential, or contingent, to persons or property. Furthermore, this warranty does not extend to loss of crop, losses caused by delays or any expense prospective profits or for any other reason. Harvest Tec, Inc. shall not be liable for any recovery greater in amount than the cost or repair of defects in workmanship.

There are no warranties, either expressed or implied, of merchantability or fitness for particular purpose intended or fitness for any other reason.

This warranty cannot guarantee that existing conditions beyond the control of Harvest Tec, Inc. will not affect our ability to obtain materials or manufacture necessary replacement parts.

Harvest Tec, Inc. reserves the right to make design changes, improve design, or change specifications, at any time without any contingent obligation to purchasers of machines and parts previously sold.

Revised 4/17

HARVEST TEC, INC.
P.O. BOX 63
2821 HARVEY STREET
HUDSON, WI 54016 USA
PHONE: 715-386-9100
FAX: 715-381-1792
Email: info@harvesttec.com