

Installation Manual

Model 796

100 & 110 Gallon Preservative Applicator



*Equipment and Products
for Quality Hay.™*

P.O. Box 63 • 2821 Harvey Street • Hudson, WI 54016
800-635-7468 • www.harvesttec.com

DECLARATION OF INCORPORATION



MANUFACTURER: Harvest Tec Inc.
2821 Harvey St.
P.O. Box 63
Hudson, WI 54016, U.S.A.

REPRESENTATIVE ESTABLISHED IN COMMUNITY: Profitable Farming Company
Middle Barlington, Roborough
Winkleigh, Devon, EX19 8AG
ENGLAND

The person above certifies and declares that:

VIRTUAL MACHINE: Equipment mounted on a farm press and for the application of inoculants onto forage crops.
MODEL: 796-INST-21-Imp&Metric
BRAND: Harvest Tec
SERIAL NUMBER:

This application preservatives for hay Harvest Tec system meets the Directive 2006/42/EC of the European Parliament and the Council of 17 May 2006 and other applicable European Directives including Directive 2004/108/EC on the Electromagnetic compatibility.

The application of preservatives for hay Harvest Tec system will be turned on after being installed on a farm press has been declared in conformity with the Machinery Directive.

Person in the community authorized to provide information on the partly completed machinery and making this statement:

Richard Snell, President, Profitable Farming Company
Signed on May 21, 2011: Middle Barlington, Roborough
Winkleigh, Devon, EX19 8AG
ENGLAND

Table of Contents

	<u>PAGE</u>
Introduction	5
Tools Needed	5
System Overview	6
Installation of Applicator	7-46
Installation of Tank Saddle, and Pump	7-15
Hesston, New Idea, Challenger, Massey Ferguson & CASE IH 8575-8590	7
Claas, John Deere 100, & Krone Balers	8
Krone 12130 and HDP Balers	9
Claas 3200 – 3400 Large Square Balers	10
Kuhn, Vicon, & Taarup balers	11
Case IH & New Holland	12
Claas 5300 Large Square Baler	13
Attach Pump Plate to Tank (with pump plate holders)	14
Attach Pump Plate to Tank (without pump plate holders)	15
Installation of Drain/Fill Line	16
Installation of Spray Shield	17-28
4490C & 4491C	17
4492C & 4494C	18
4495C, 4528C, 4497C & 4529C	19
4498C & 4499C	20
4500C & 4501C	21
4509C & 4510C	22
4511C & 4514C	23
4515C & 4525C	24
4537C & 4539C	25
4540C	26
4541C	27
Installation of Solenoids	28
Installation of Main Wire Harness	29
Identifications of Plugs	29
Installation of Star Wheel Moisture Sensors	29-36
New Holland 590-BB960, BB9060-BB9080 & Case IH LBX 331-431, LB333-LB433	30
Challenger LB33, LB34, Hesston 7430, 4750, 4755, 4760, 4790, Massey Ferguson 2050, New Idea 7233, 7333, 7234	31
Hesston 4900, 4910, Challenger LB44 & New Idea 7244	32
Claas 2100 & 2200	33
Claas 3200 – 3400, 5300	34
Krone Large Square Balers	35
Kuhn, Vicon and Taarup Balers	36
Installation of End of Bale Sensor	37-45
Hesston 4760 – 4790 and equivalents, Case IH LBX 331 – LB 433, Class 2100, John Deere 100, New Holland 590 – BB 9080, Hesston 4750 – 4755 & 4900 – 4910	37
Krone 890-12130, Kuhn, Vicon and Taarup Balers	38
End of Bale Sensor Bracket Installation	39-45
Hesston 4750-4755 and 4900-4910	39
Hesston 4760 and 4790	40
Claas 2100, 3200-3400 and 5300	41
John Deere 100	42
Krone 890-1290	43
Krone 12130	44
Kuhn, Vicon and Taarup Balers	45

Table of Contents (continued)

	<u>PAGE</u>
Tractor Setup	46
Display Options	47
Optional Harvest Tec Display	47
Optional Tablet Display	47
Wiring Diagram	48
Pin Outs	49-51
Parts Breakdown	52-83
Tank, Saddle and Saddle Legs – 100 Gal Tanks	52-54
Pump Assembly	55
Star Wheel Sensors & Moisture Harness	56
Control Box and Wiring Harnesses	57
End of Bale Sensor Kit	57
700 Series Solenoid Package	58
Hoses and Drain / Fill Line	59
Optional iPad Mini Mounting Kit	60
Optional iPad Display Kit	61
Optional Android Display Kit	62
Optional Harvest Tec Display Kit (Virtual Terminal)	63
Model Specific Installation Kits	63-84
Installation kit 4490C	64
Installation kit 4491C	65
Installation kit 4492C	66
Installation kit 4494C	67
Installation kit 4495C	68
Installation kit 4497C	69
Installation kit 4498C	70
Installation kit 4499C	71
Installation kit 4500C	72
Installation kit 4501C	73
Installation kit 4509C	74
Installation kit 4510C	75
Installation kit 4511C	76
Installation kit 4514C	77
Installation kit 4515C	78
Installation kit 4525C	79
Installation Kit 4529C	80
Installation kit 4537C	81
Installation Kit 4539C	82
Installation Kit 4540C	83
Installation Kit 4541C	84
Vicon Star Wheel Install Template	85
Star Wheel Install Template	86
Warranty Statement	87

Introduction

Thank you for purchasing the 700 series hay preservative applicator system. This applicator system has been designed to be operated through an optional Harvest Tec display, an iOS/Android tablet (not included) using the Precision Baling App, or to plug directly into an ISOBUS display.

The 700 Series Preservative Applicator System is designed to apply buffered propionic acid to the forage crop as it is baled. Failure to follow instructions can result in personal injury or equipment malfunction. If you need parts for the system, please view the Parts Breakdown toward the back of this manual and contact your local authorized dealer to order the parts. This applicator is designed to apply Harvest Tec buffered propionic acid.

Right and Left sides are determined by facing in the direction of forward travel.

System Requirements



Made for Harvest Tec Display, Baler Integration, or Tablet
For best performance ensure all displays are running the latest operating system.



Tools Needed:

- Standard wrench set
- Electric drill and bits
- Side cutter
- Crescent wrench
- Standard screwdriver
- Center punch
- Standard nut driver set
- Standard socket set
- Hammer
- Metal cutting tools
- Hose cutter

System Overview

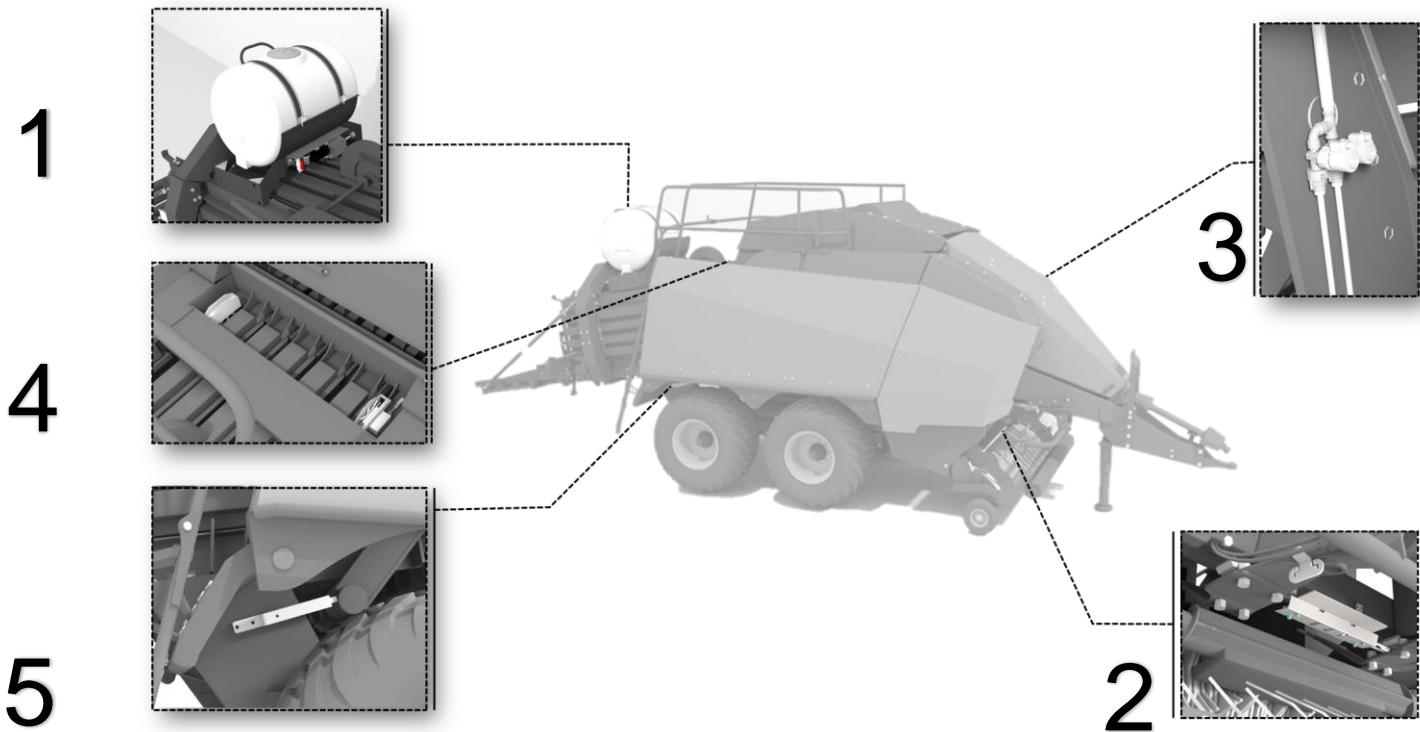

The 700 series applicator system consists of five main areas of installation, these include:

- 1) Tank Mounting Installation
- 2) Spray Shield Installation
- 3) Solenoid Installation
- 4) Star Wheel Installation
- 5) End of Bale Installation

Tank, Saddle, and Pump, Installation

This will mount on the bale chute towards the rear of the baler. All mounting and parts should be verified prior to beginning installation. Follow *Installation of Tank, Saddle, and Pump* section for step-by-step instruction.

Spray Shield Installation

The spray shield assembly is designed to spray the hay evenly as the baler picks it up. This holds the tips and is connected to plumbing to apply preservative as precisely as possible. Follow the *Installation of Spray Shield* section for sketches of the spray shield nozzle holders and step-by-step instruction.

Solenoid Installation

The dual solenoid setup is to be mounted as close to the spray shield as possible. This will provide the best result to ensure the proper output of preservative is applied through the nozzles. Follow *Installation of Solenoids and hose routing* section for step-by-step instructions.

Star Wheel Installation

This is the moisture setup for the applicator system, installation will be done on top of the bale chamber so the star wheels can make sufficient contact with the bale. Follow *Installation of Star Wheel Moisture Sensor* sections for step-by-step instruction.

End of Bale Installation

The end of bale sensor determines the position of the needles on the baler. When the needles cycle the sensor communicates this information to the 700 series. Installation of this sensor is required for use with the Harvest Tec Virtual Terminal. Follow *Installation of End of Bale Sensor* section for step-by-step guide.

Installation of Tank, Saddle and Pump

Hesston, New Idea, Challenger, and Case 8575-8590 Balers:

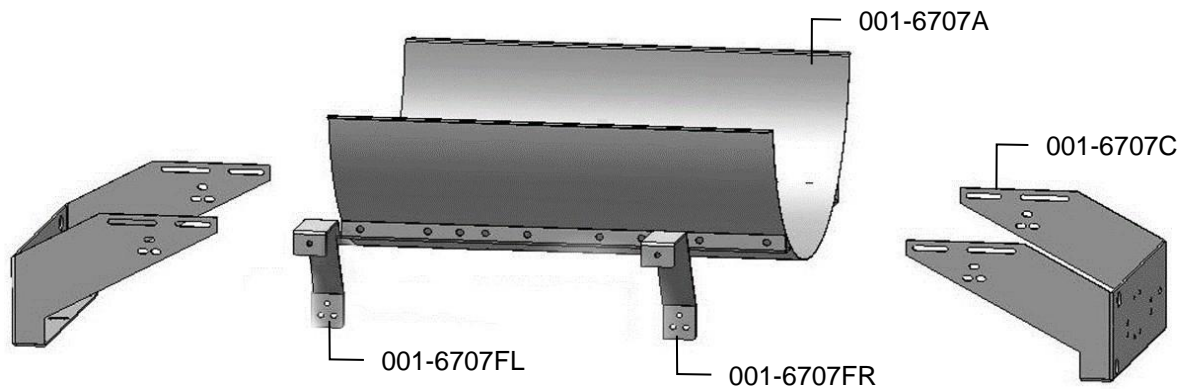

1. Locate parts bag 2. Install both saddle legs (001-6707C) onto the saddle (001-6707A) with eight 3/8" x 1-1/4" bolts, locks, and flat washers. Note: For 3 x 3 balers the slots in the legs will attach to the second and fourth weld nuts in from each end, of the saddle, on both sides. For 3 x 4 or 4 x 4 balers the slots in the legs will attach to the first and second weld nuts in from each end, of the saddle, on both sides.
2. Once legs and saddle are loosely attached measure the distance from the top outside corners of the bale chamber where the saddle will be attached. Move legs in or out so the outside edges will match this dimension. Also try to center the saddle within these dimensions. Do not fully tighten bolts until mounted on the baler.
3. Locate parts bag 6. Mount the pump plate support legs (001-6707FL & 001-6707FR) to the saddle legs using six 3/8" x 1" bolts, locks, flats, and nuts. Note: This will be the same side as the handrail on the tank.
4. Mount the tank legs and saddle on the baler just behind the compression arm. If holes are not present, mark holes and drill with a 9/16" drill bit. The tank legs bolt to the baler with six 1/2" x 1 3/4" carriage head bolts, locks, flat washers, and hex nuts. Note: handrail is pointing toward front of baler. Tank cap should be parallel to ground.

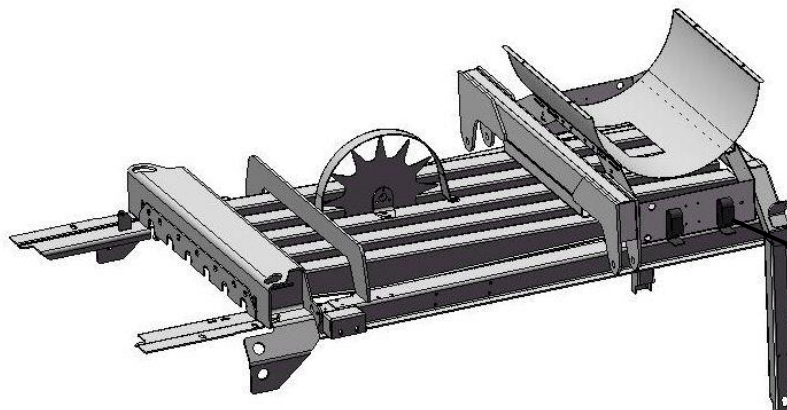

For Hesston 4900, 4910 and Case 8590 Attach 001-6707H here.

Claas, John Deere 100, and Krone Balers

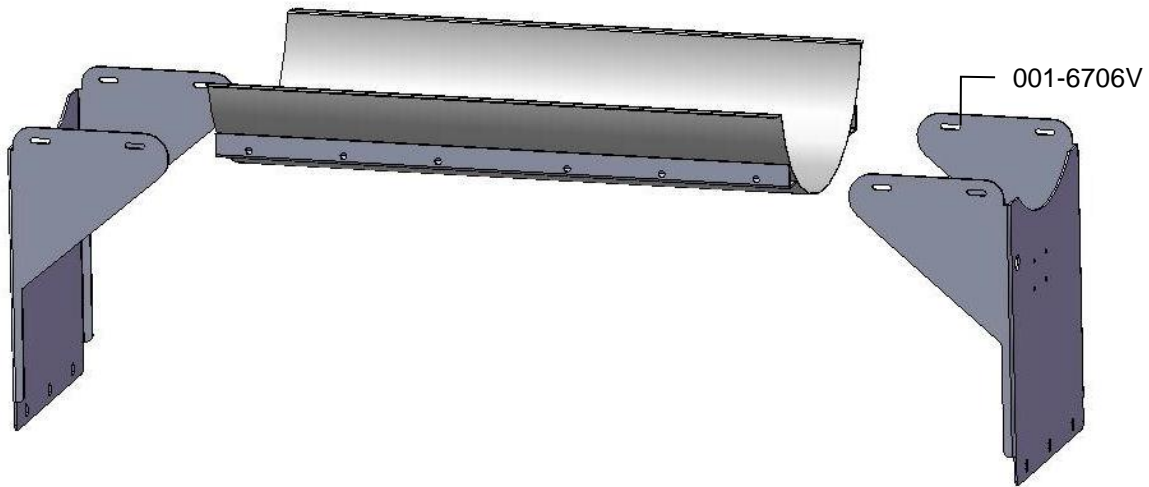

1. Locate parts bag 3. Install both saddle legs (001-6706V) onto the saddle (001-6706A) with eight 3/8" x 1-1/4" bolts, locks, and flat washers. Note: For 3 x 3 balers the slots in the legs will attach to the second and fourth weld nuts in from each end, of the saddle, on both sides. For 3 x 4 or 4 x 4 balers the slots in the legs will attach to the first and second weld nuts in from each end, of the saddle, on both sides.
2. Once legs and saddle are loosely attached measure the distance from the top outside corners of the bale chamber where the saddle will be attached. Move legs in or out so the outside edges will match this dimension. Also try to center the saddle within these dimensions. Do not fully tighten bolts until mounted on the baler.
3. Depending on your baler, mount the tank legs and saddle on the baler just in front of or behind the compression arm. If holes are not present, mark holes and drill with a 9/16" drill bit. The tank legs bolt to the baler with six 1/2" x 1 3/4" button head allen bolts, locks, flat washers, and hex nuts. Note: handrail is pointing toward front of baler. On some Krone balers you will need to switch the handrail to the back of the baler. Tank cap should be parallel to the ground.

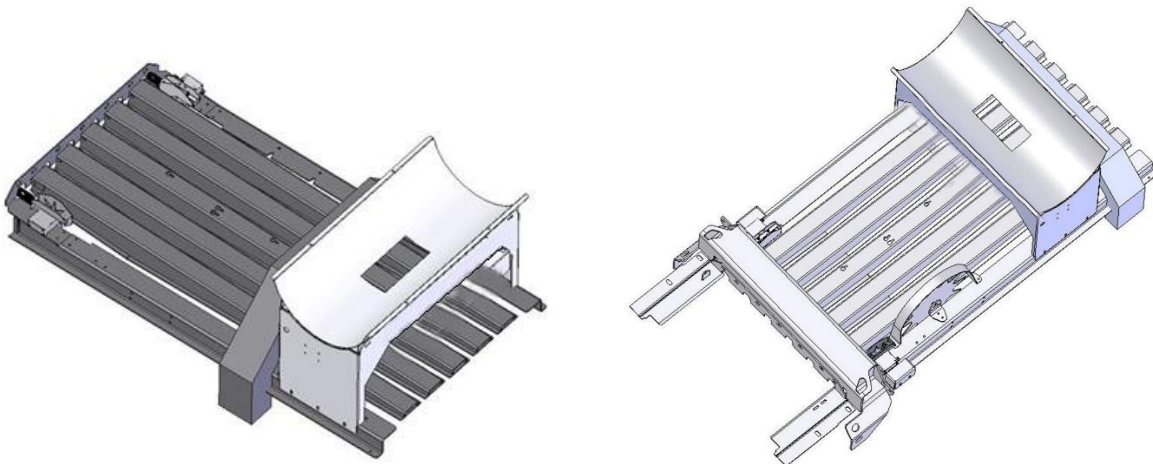

*If the applicator is being mounted onto a **Krone 870 HDP, 1270, or 1290 HighSpeed** baler, two leg adapter brackets will be needed for proper tank leg installation. Part number 001-6707KV as seen in the image to the right.

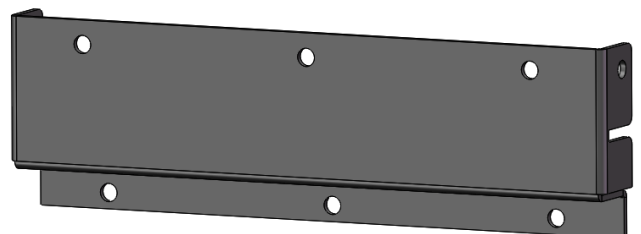

Contact your dealership for details.

Krone 12130 & HDP Balers
(excluding 870 HDP – refer to previous install)

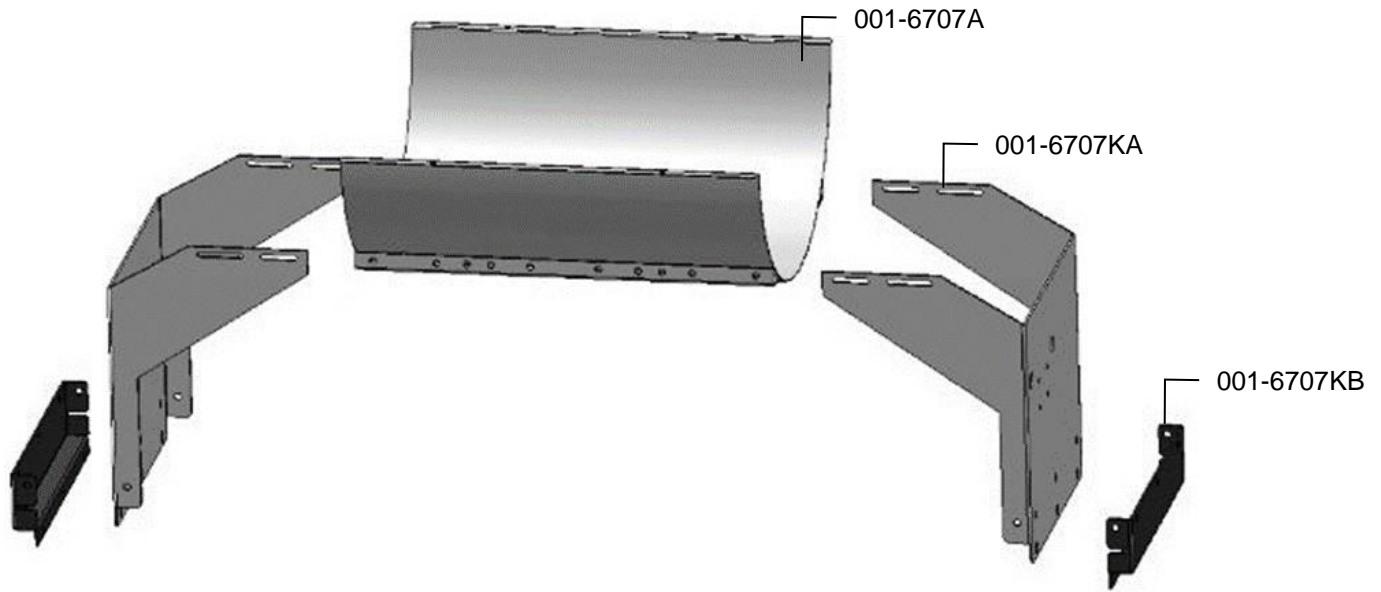

1. Locate parts bag 3. Install both saddle legs (001-6707KA) onto the saddle (001-6707A) with eight 3/8 x 1 1/4" Bolts, locks and flat washers. The mounting slots in the legs will attach to the first and second weld nuts in from each end, of the saddle, on both sides. *Install leg extensions 001-6707KB if the baler was manufactured after 2010. Pre-2010 models do not need the extensions.
2. Once legs and saddle are loosely attached measure the distance from the top outside corners of the bale chamber where the saddle will be attached. Move legs in or out so the inside edges will match this dimension. Also try to center the saddle within these dimensions. Do not fully tighten down bolts until unit is mounted on the baler
3. Mount the tank legs and saddle on the baler just behind the compression arm. If holes are not present, mark holes and drill with a 9/16" drill bit. The tank legs bolt to the baler with six 1/2" x 1 3/4" button head allen bolts, locks, flat washers, and hex nuts. Note: handrail is pointing toward front of baler. Tank cap should be parallel to the ground.

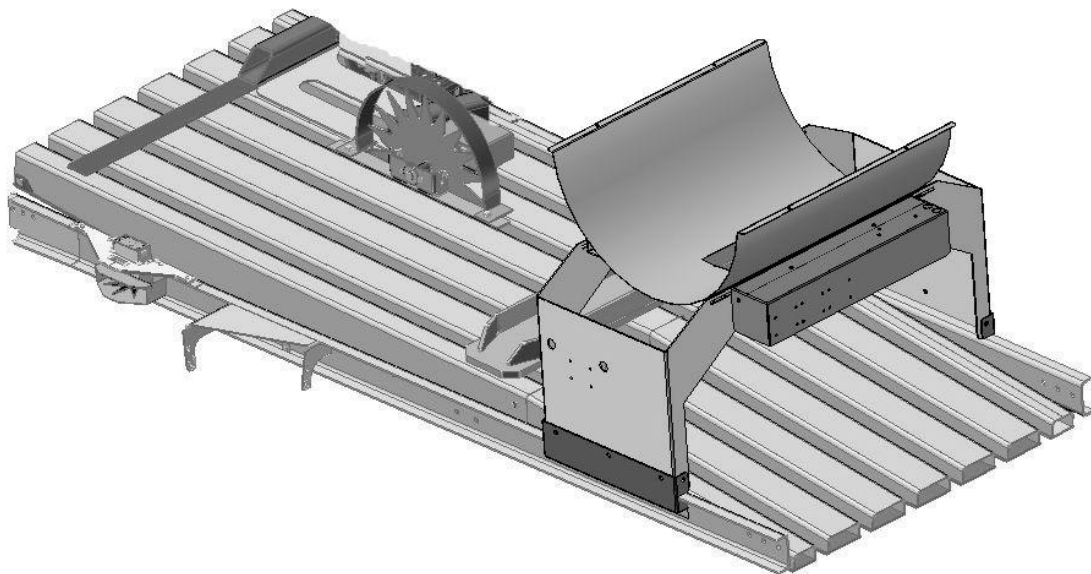

Claas 3200-3400 Large Square Balers

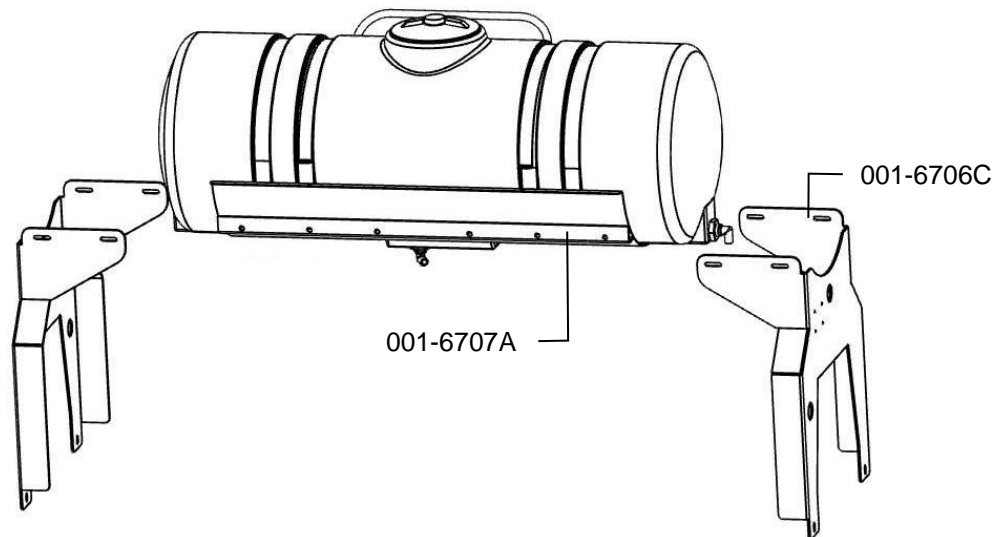

1. Prior to the installation of the tank assembly on the baler, the factory handrail support that connects the handrail to the rear tension beam must be removed. The hardware used to mount the support to the railing is reused when securing the handrail.
2. Fasten the legs (001-6706C) to the saddle (001-6706A) with eight $\frac{3}{8}$ " x $1\frac{1}{4}$ " bolts, lock washers, and flat washers. The inside distance of the legs should be approximately 48" (1.2M). Note that the tank fitting on the side of the tank should be towards the right side of the baler, opposite the ladder. Install the supplied rail support (001-6706CC) to the front side of the tank saddle using two $\frac{3}{8}$ " x $1\frac{1}{4}$ " bolts, lock washers, and flat washers.
3. Lift the tank assembly into place so it straddles the rear tension beam on top of the baler, near the end of the bale chamber. The tank legs should rest on the top corners of the bale chamber. Slide the tank as far forward as possible. With the tank slid as far forward as possible, attach the handrail to the rail support (001-6706CC) using the factory hardware. Clamp the legs to the sides of the bale chamber and drill two $\frac{9}{16}$ " (14mm) diameter holes per leg on each side of the bale chamber. Secure the legs to the chamber with (x4) $\frac{1}{2}$ " x $1\frac{1}{2}$ " allen head bolts, flat washer, lock washer, and hex nut. Tank cap should be parallel to the ground.

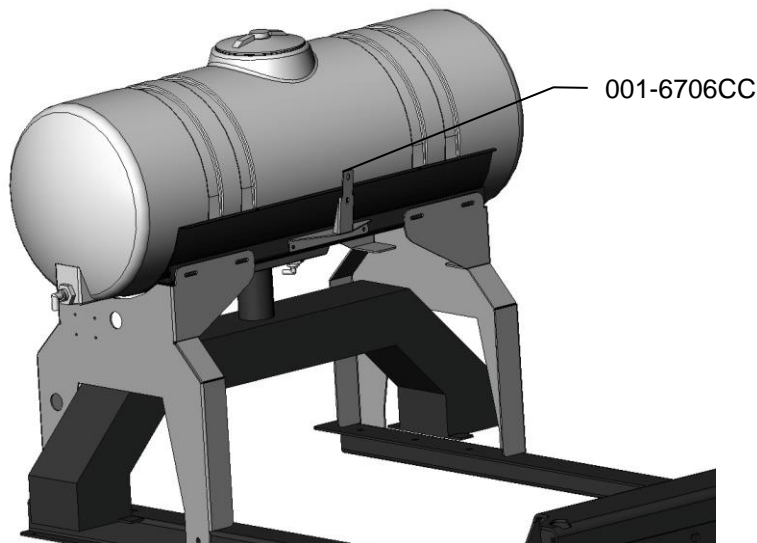

Kuhn, Vicon & Taarup Balers

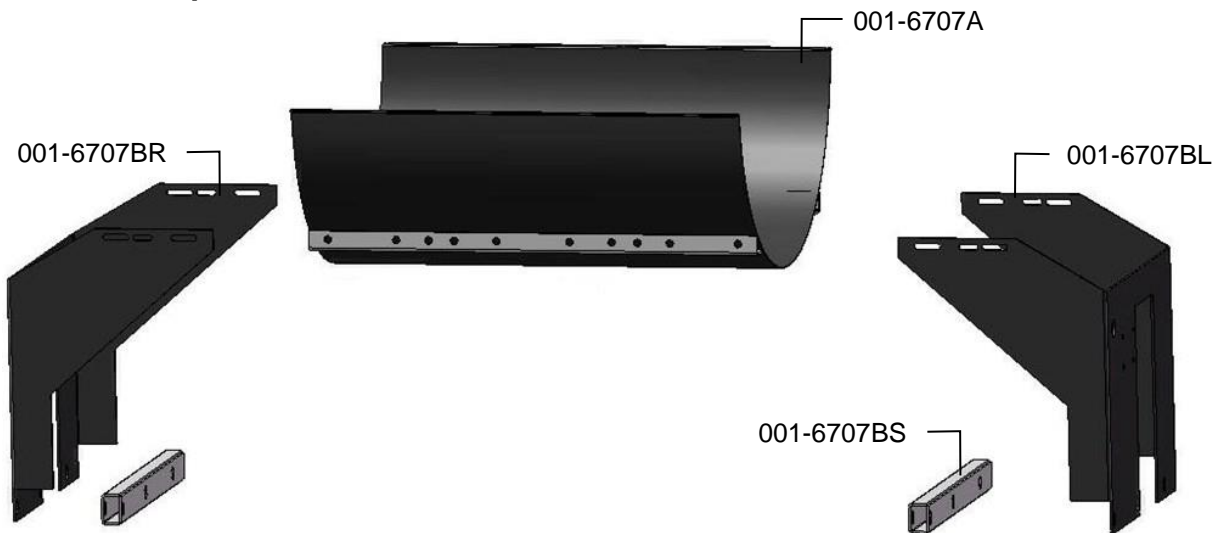

1. Locate parts bag 4. Install both saddle legs (001-6707BL & 001-6707BR) onto the saddle (001-6707A) with eight 3/8" x 1-1/4" Bolts, locks, and flat washers. Note: For 3 x 3 balers the mounting slots in the legs will attach to the second and fourth weld nuts in from each end, of the saddle, on both sides. For 3 x 4 balers the mounting slots in the legs will attach to the first and second weld nuts in from each end, of the saddle, on both sides Note: There is a "V" shape cut out in the sump area of the saddle. This side of the saddle should be attached to the side of the legs that have a narrower profile.
2. Once legs and saddle are loosely attached measure the distance from the top outside corners of the bale chamber where the saddle will be attached. Move legs in or out so the inside edges will match this dimension. Also try to center the saddle within these dimensions. The spacers (001-6707BS) will be needed between the saddle legs and frame of the baler. Do not fully tighten down bolts until unit is mounted on the baler.
3. Depending on the baler, mount the tank legs and saddle on the baler just in front of or behind the compression arm. If holes are not present, mark holes and drill with a 9/16" drill bit. The tank legs bolt to the baler with six 1/2" x 3 1/2 carriage head bolts, locks, flat washers, and hex nuts. Note: handrail is pointing toward front of baler. Tank cap should be parallel to the ground.

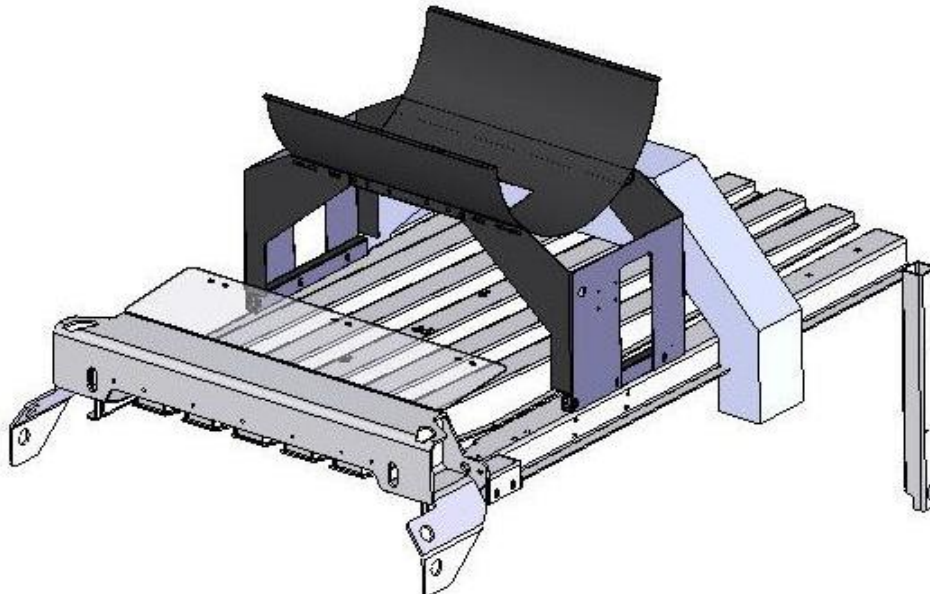

Case IH and New Holland Balers

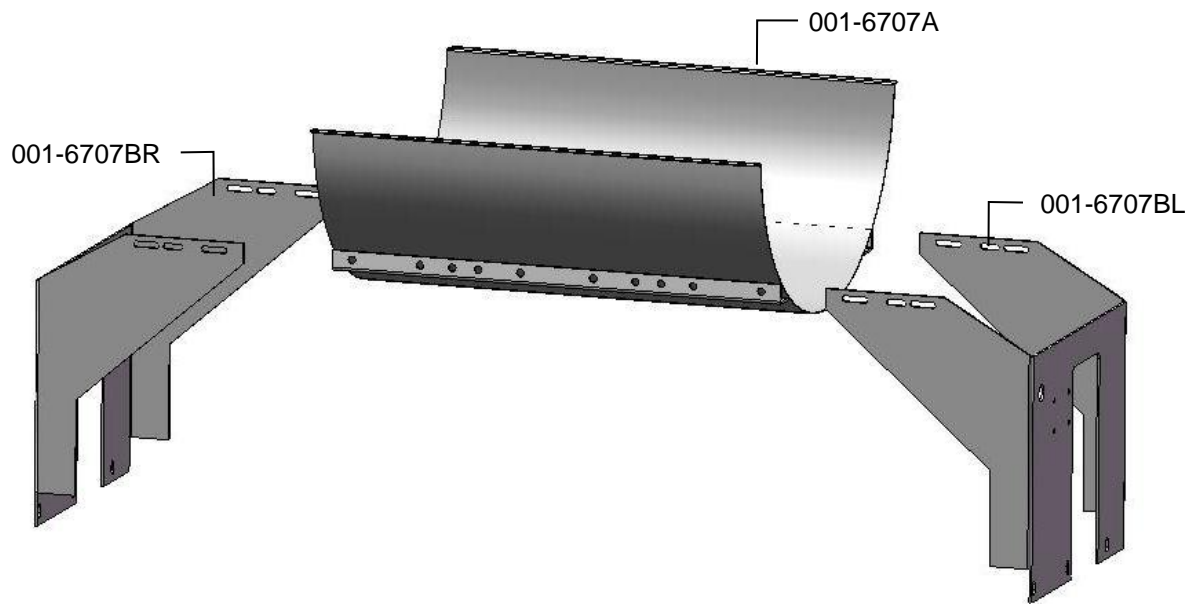

1. Locate parts bag 2. Install both saddle legs (001-6707BL & BR for 3 ft wide or 001-6707DL & DR for 4 ft wide balers) onto the saddle (001-6707A) with eight $\frac{3}{8}$ " x 1- $\frac{1}{4}$ " Bolts, locks, and flat washers. Note: 3 x 3 balers the mounting slots in the legs will attach to the second and fourth weld nuts in from each end, of the saddle, on both sides. For 3 x 4 balers the mounting slots in the legs will attach to the first and second weld nuts in from each end, of the saddle, on both sides. There is a "V" shape cut out in the sump area of the saddle. This side of the saddle should be attached to the side of the legs that have a narrower profile.
2. Once legs and saddle are loosely attached, measure the distance from the top outside corners of the bale chamber where the saddle will be attached. Move legs in or out so the inside edges will match this dimension. Also try to center the saddle within these dimensions. Do not fully tighten down bolts until unit is mounted on the baler.
3. Mount the tank legs and saddle on the baler over the compression arm. If holes are not present, mark holes and drill with a $\frac{9}{16}$ " drill bit. The tank legs bolt to the baler with six $\frac{1}{2}$ " x 1 $\frac{3}{4}$ " carriage head bolts, locks, flat washers, and hex nuts. Note: handrail is pointing toward front of baler. Tank cap should be parallel to the ground

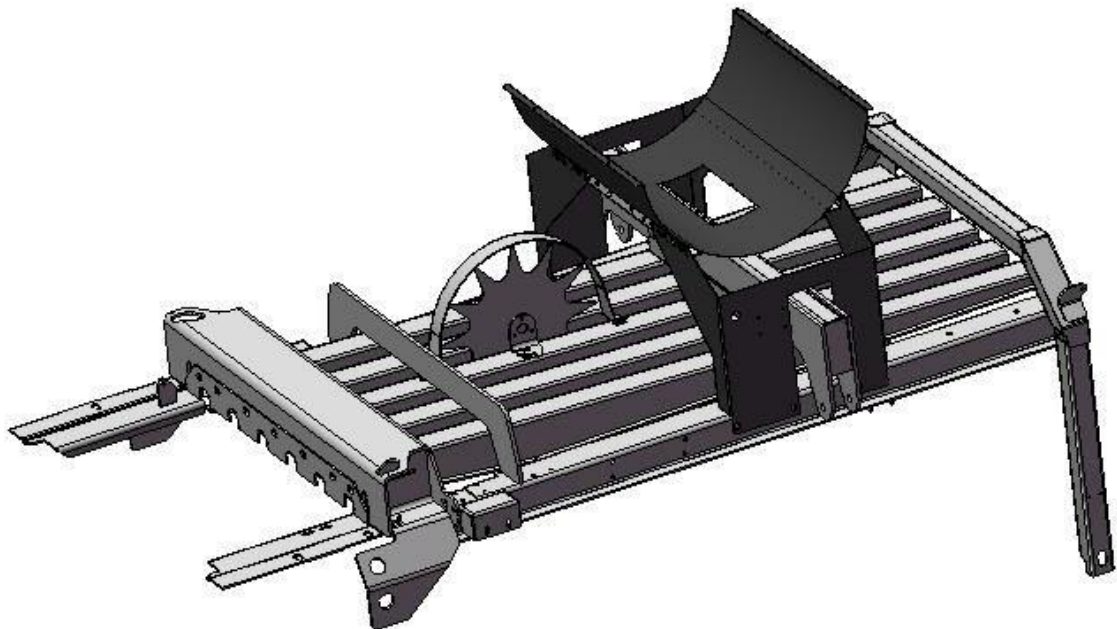

Claas 5300 Baler

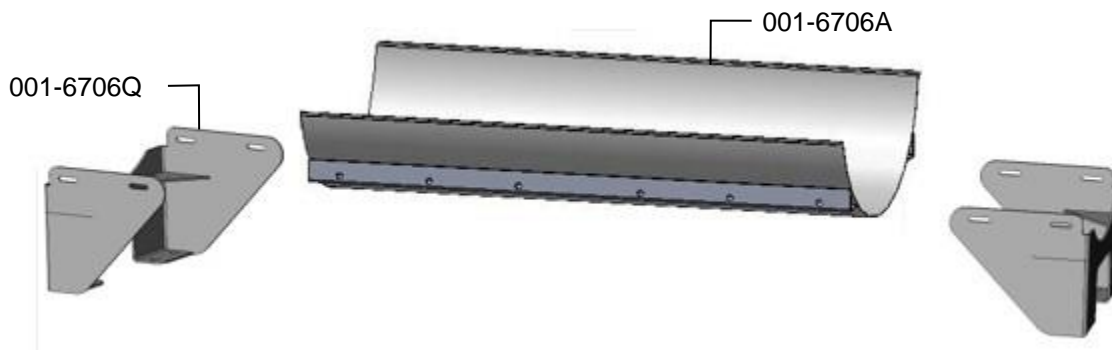

1. Locate parts bag 21. Install both saddle legs (001-6706Q) onto the saddle (001-6706A) with six 3/8" x 1-1/4" bolts, locks and flat washers. The mounting slots in the legs will attach to the second and third weld nuts in from each end, of the saddle, on both sides.
2. Once legs and saddle are loosely attached measure the distance from the top outside corners of the bale chamber where the saddle will be attached. Move legs in or out so the inside edges will match this dimension. Also try to center the saddle within these dimensions. Do not fully tighten down bolts until unit is mounted on the baler.
3. Four M10 weld nuts should be on the top of the baler on each side in location shown below. Line up saddle legs over these holes. Place two 10mm washers into the mounting holes of saddle legs. Secure legs to baler with M10 x 40mm bolts, lock washer, and two fender washers per hole.



Attach Pump Plate to Tank Saddle (with pump plate holders)

1. Attach (001-4648XB) Bracket to pump plate brackets (001-6707FL/FR) with remaining hardware from #6 parts bag.
2. Connect control (006-7671LS) to pump plate (PMP-7636P) with four 10/32" x 5/8" Philips flat head screws and nylock nuts.
3. Attach triangle plug from flow meter to controls and rubber molded plug from pump to mating plug from control.
4. Attach pump plate assembly (PMP-7636P) to bracket (001-4648XB) with two 3/8" x 3/4" flange bolts and nuts.
5. Locate parts bag 16. Locate elbow (003-EL3412) and thread into bottom of tank.
6. Locate parts bag that was with pump plate assembly and choose fitting to place in valve next to filter.
7. Run 1/2" hose from bottom of tank to valve on pump plate and secure with hose clamps.
8. Chose and thread fitting into pump discharge.

Note: Pressure washing the pump plate can lead to water damage internally of the ISO Pump Module (IPM).

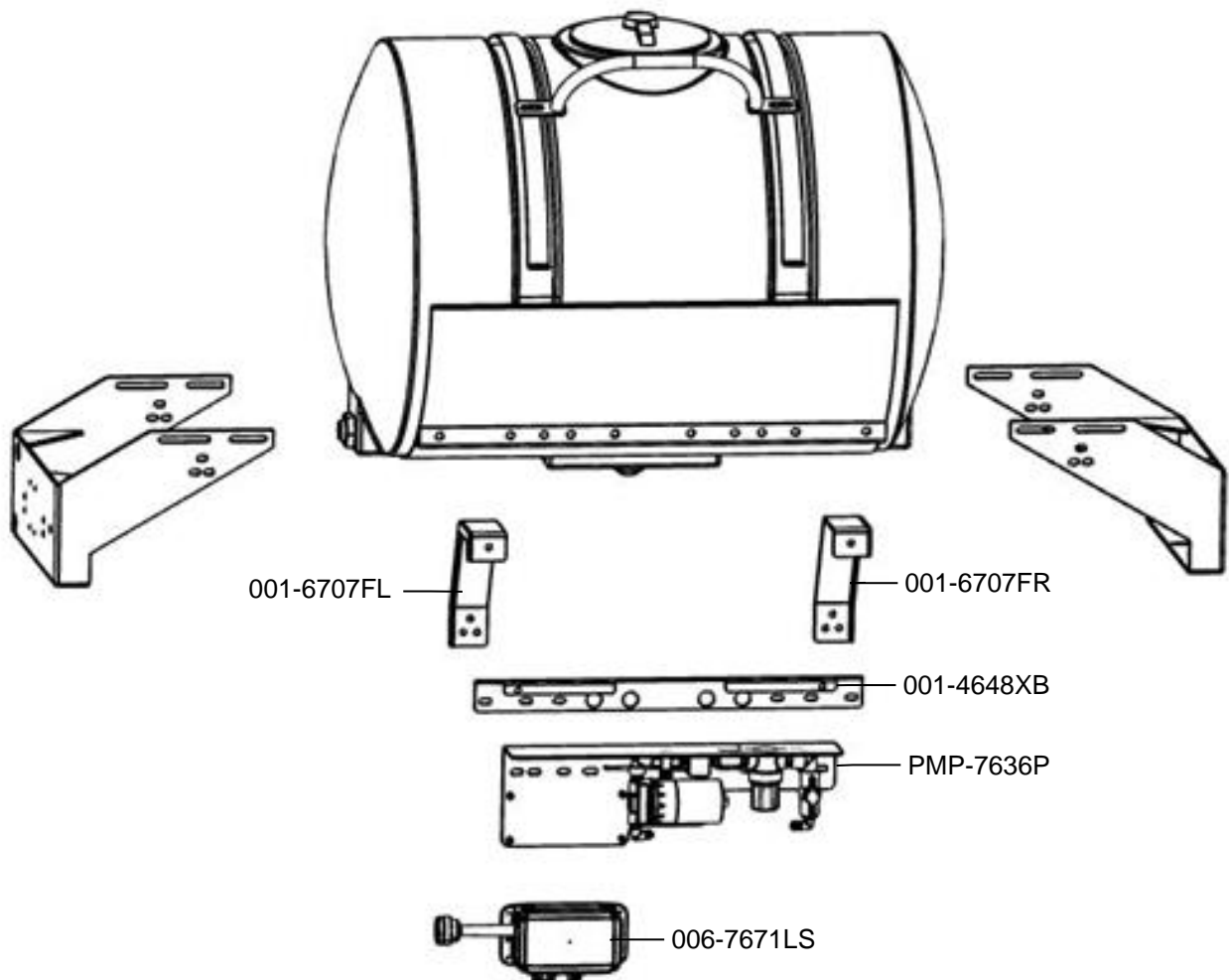

Attach Pump Plate to Tank Saddle (without pump plate holders)

1. Attach (001-4648XB) Bracket to main saddle. Holes in bracket will line up with holes in main saddle. You may need to remove two of the bolts used to attach saddle to legs for bracket to fit. Reuse bolts to secure bracket to saddle and legs. Note some Krone and Claas balers will require you to mount the pump assembly facing the rear of the baler due to interference with balers compression ring. However, most models will be facing the knotters.
2. Connect control (006-7671LS) to pump plate (PMP-7636P) with four 10/32" x 5/8" Philips flat head screws and nylock nuts.
3. Attach triangle plug from flow meter to controls and rubber molded plug from pump to mating plug from control
4. Attach pump plate assembly (PMP-7636P) to bracket (001-4648XB) with two 3/8" x 3/4" flange bolts and nuts.
5. Locate parts bag 16. Locate elbow (003-EL3412) and thread into bottom of tank.
6. Locate parts bag that was with pump plate assembly and choose fitting to place in valve next to filter.
7. Run 1/2" hose from bottom of tank to valve on pump plate and secure with hose clamps.
8. Chose and thread fitting into pump discharge.

Note: Pressure washing the pump plate can lead to water damage internally of the ISO Pump Module (IPM).

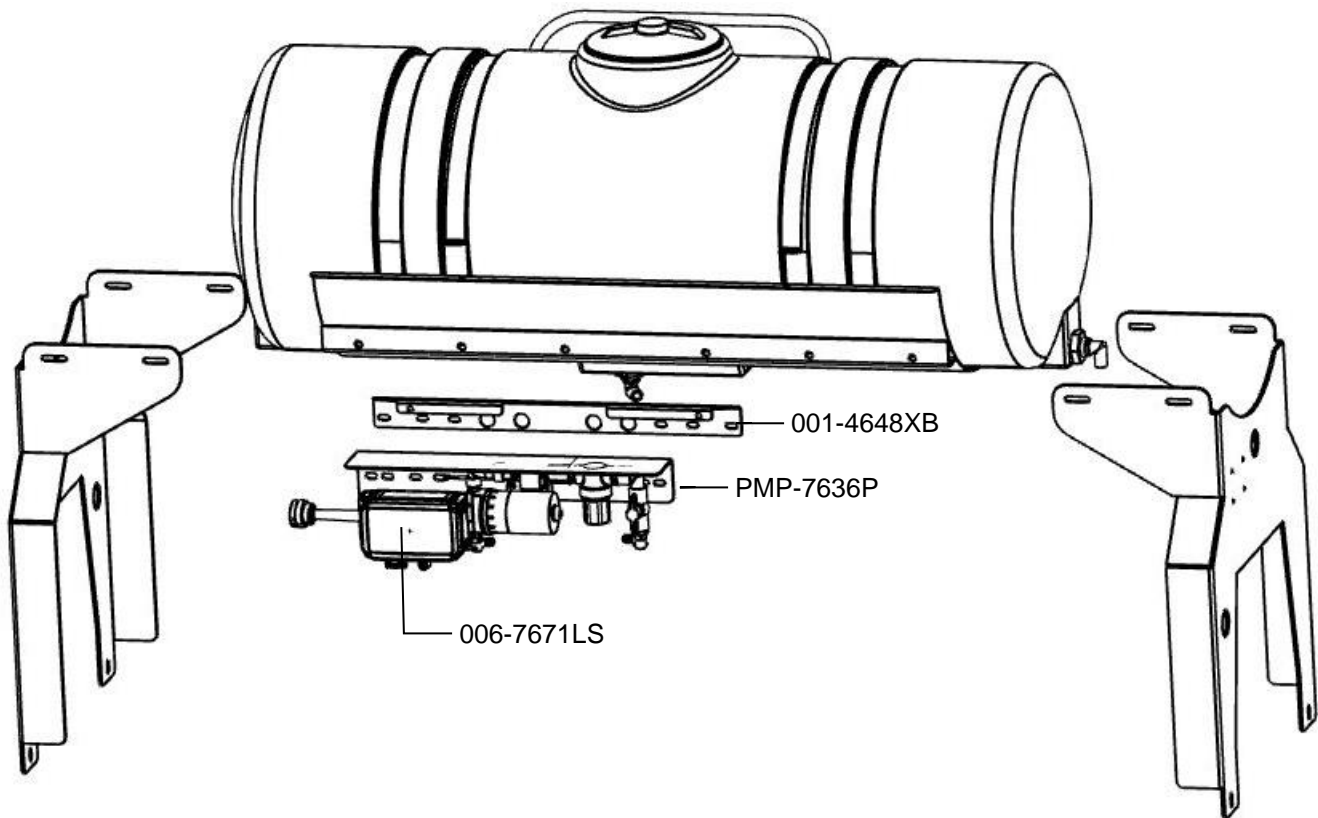

Installation of the Drain/Fill Line

1. Locate parts bag 1.
2. Thread 3/4" elbow fitting into end of tank.
3. Run hose from the elbow down the frame to the bottom of the baler.
4. Drill 1/4" (7mm) holes to accept the valve holder bracket and use 5/16" x 1" self-tapping screws.
5. Connect valve assembly to other end of hose. Place hose clamps on both ends.
6. Secure hose to frame using cable locks.
7. Install supplied safety decals (DCL-8001 & DCL-8005) next to the ball valve assembly.

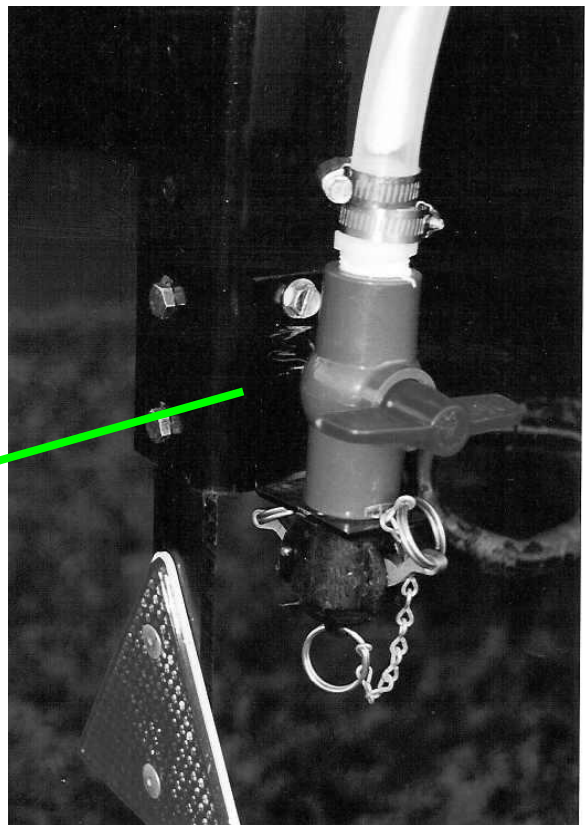
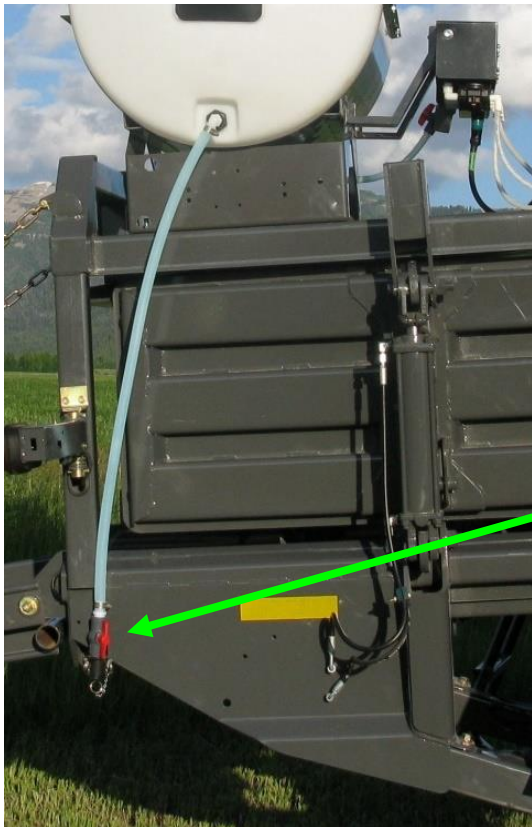

Installation of the Spray Shield

The spray shield assembly is designed to spray the hay evenly as the baler picks it up. A sketch of the spray shield nozzle holder and installation instructions are shown below.

Installation Kit 4490C

The spray shield holder will be installed underneath the baler's tongue. Bolt the right side up using the existing hole on the bottom lip of the baler. Use the clamp on the left-hand side to tighten the shield against the underside of the tongue. Tighten the clamp with the two bolts provided. A parts breakdown of the 4490C is located in the back of this manual.

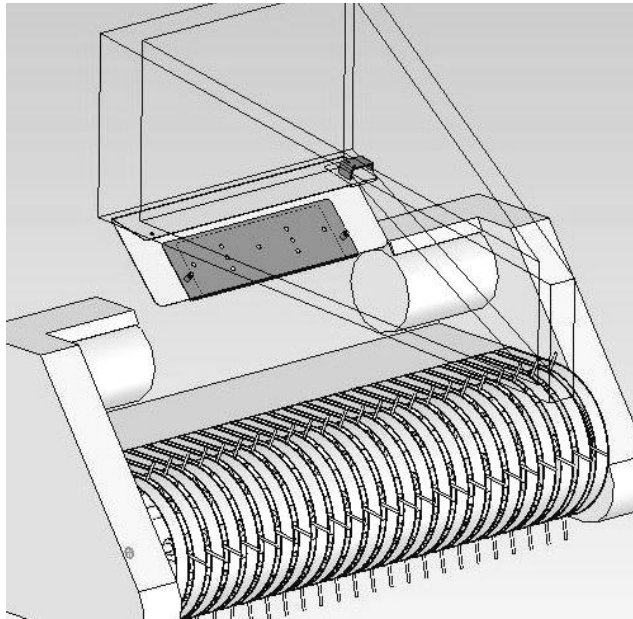

Installation Kit 4491C

Install the spray shield behind the baler's cross channel, which is located on the bottom side of the tongue behind the flywheel. Note the position of the bevel on the spray shield. Clamp the spray shield around the channel using the backing plates and the 1/4" x 7" (7mm x 18cm) bolts provided. A parts breakdown of the 4491C install kit is shown in the back of this manual.

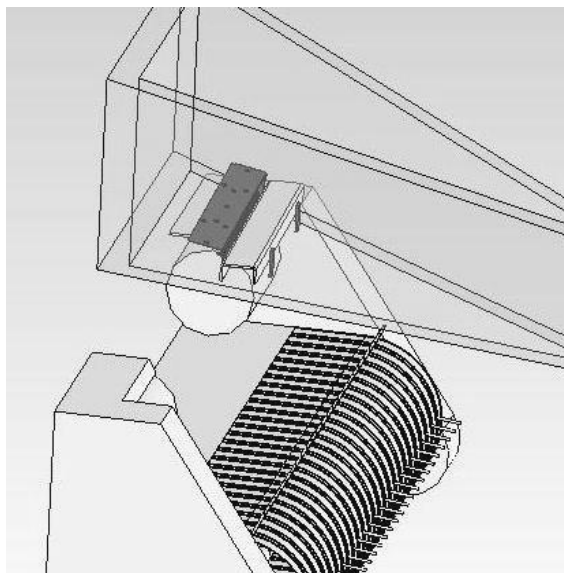

Installation Kit 4492C

Remove the two 3/8" carriage bolts that connect the wrapper extension to the angle support on each side. Place the brackets 001-4436DL and 001-4436DR between the angle support and the wrapper extension. Replace the bolts with 3/8" x 1-1/4" carriage bolts, nuts, locks, and flat washers. Before tightening pull down on wrapper extensions so when tightened the bolts are in the top of the wrapper extension slot. Install the wind guard stops 001-4436S as shown below. Two holes will need to be drilled per side. Mount using four 1/4" x 1" bolts, locks and nuts. A parts breakdown of the 4492C install kit is shown in the back of this manual.

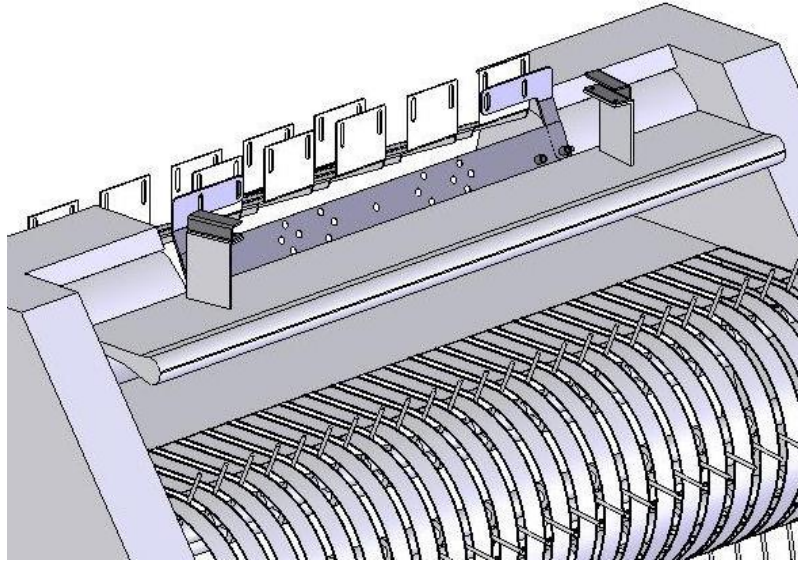

Installation Kit 4494C

Remove the two 3/8" carriage bolts that connect the wrapper extension to the angle support on each side. Place the brackets 001-4436DL and 001-4436DR between the angle support and the wrapper extension. Replace the bolts with 3/8" x 1-1/4" carriage bolts, nuts, locks, and flat washers. Before tightening pull down on wrapper extensions so when tightened the bolts are in the top of the wrapper extension slot. Install the wind guard stops 001-4436S as shown below. Two holes will need to be drilled per side. Mount using four 1/4" x 1" bolts, locks and nuts. A parts breakdown of the 4494C install kit is shown in the back of this manual.

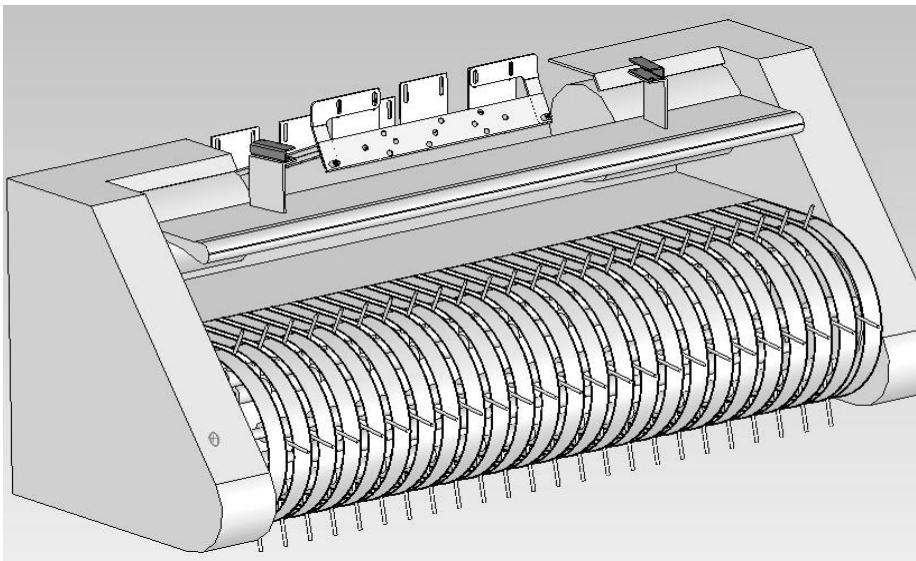

Installation Kit 4495C & 4528C

New Holland and Case: Install the spray shield under the tongue of the baler, behind the flywheel. There are two existing bolt holes 6" - 12" (15cm-30cm) above the gathering fork guards, connect the spray shield using these holes. The tips should be pointing to the throat of the baler chamber. Install the wind guard stop as shown below 2" (51mm) behind the bend in the baler frame. A parts breakdown of the 4495C, 4528C install kit is located in the back of the manual.

Krone: Install the spray shield under the tongue of the baler in front of the flywheel. You will need to drill two holes directly in front of the flywheel to secure the shield on the baler. The tips should be pointing to the throat of the baler chamber. A parts breakdown of the 4495C, 4528C install kit is located in the back of the manual.

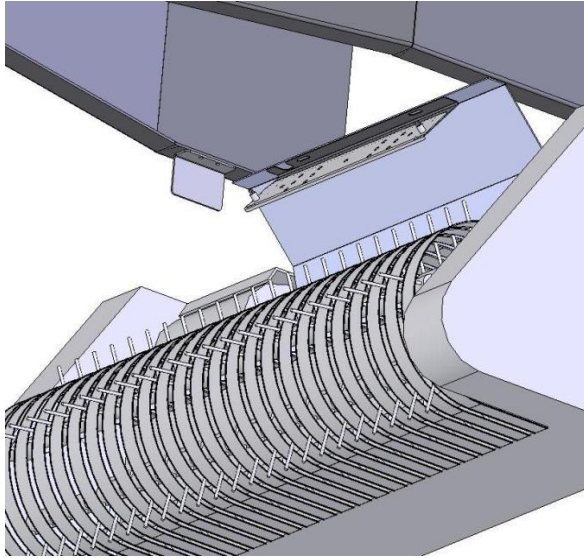

New Holland and Case

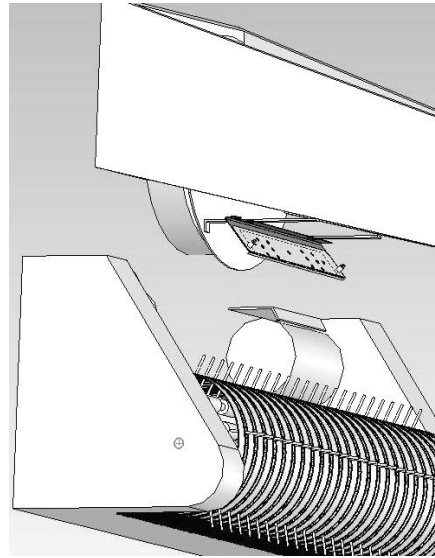

Krone

Installation Kit 4497C & 4529C

Attach shield to cross member as shown in picture below. Center the shield above the rotor. Four holes will need to be marked and drilled. Use supplied 3/8" x 1-1/4" inch bolts, nuts, and lock washers to attach the shield holders (001-4435E) to the metal cross member directly above the rotor. Attach the spray shield (001-4435ES) to the holders and secure with lynch pins. **The shield is set up for 3X4 balers. Use the inside holes on the shield for 3X3 balers and the outside holes for 3X4 balers.** A parts breakdown of the 4497C, 4529C install kit is located in the back of the manual.

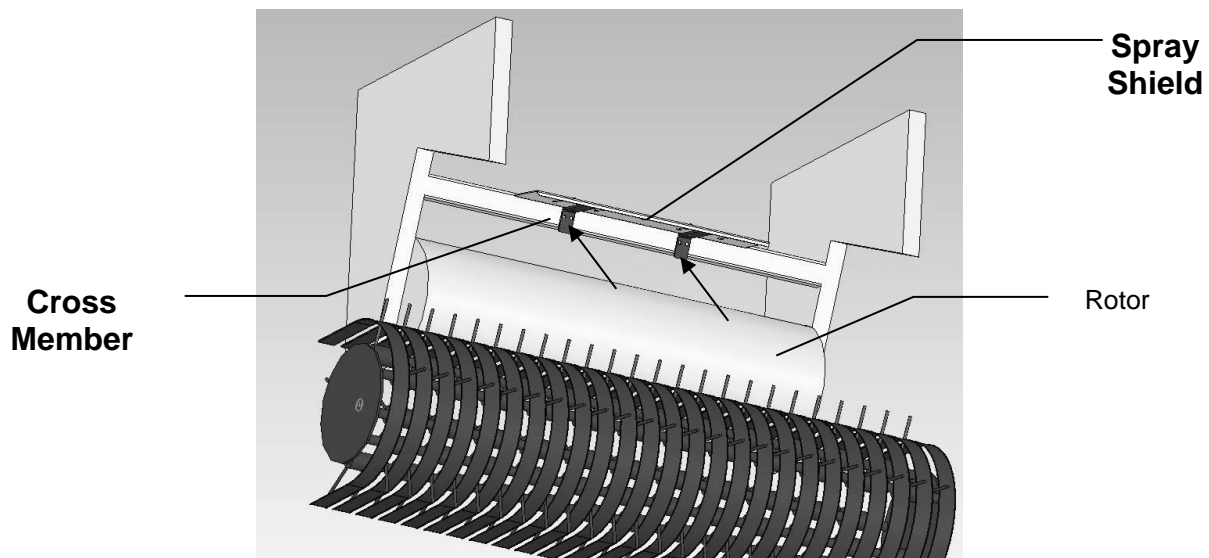

Installation Kit 4498C

Lower the wind guard of the baler to maximize the installation working space. Locate the guards between the hay intake fingers. Hold the spray shield up so it straddles the top of the guards. Locate the holes on the baler that line up with the spray shield holders. Connect the spray shield to the baler using the existing bolts. Adjust the spray shield so it can be removed and reinstalled freely once the lynch pins are removed. A parts breakdown of the 4498C install kit is shown in the back of this manual.

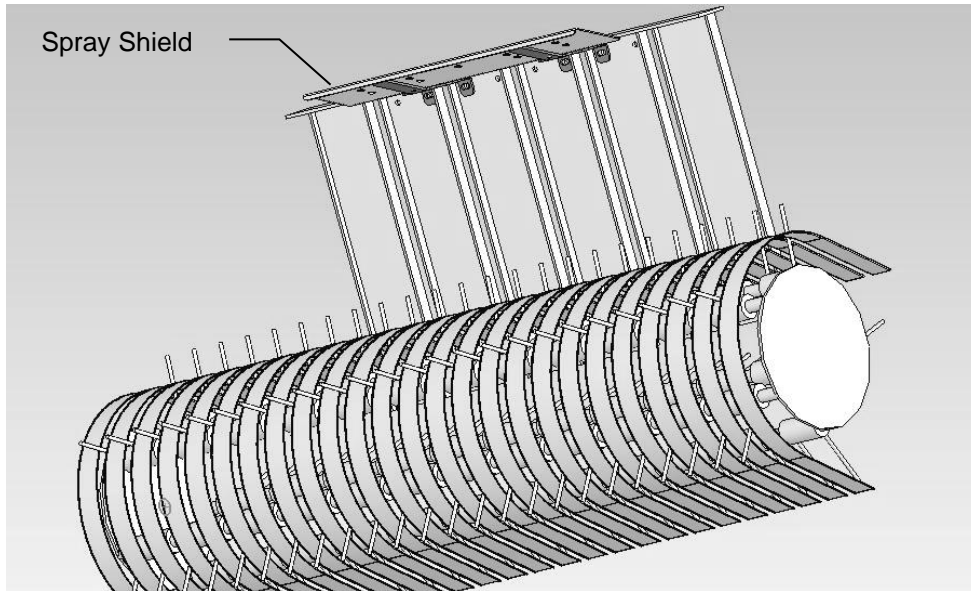

Installation Kit 4499C

Install the spray shield-mounting bracket between the two flat vertical plates above the rotor as indicated in the picture below. Use the existing bolt holes with the hardware from the applicator kit to mount the spray shield bracket to the baler. Fasten the spray shield onto the spray shield bracket already mounted. Route hoses along the spray shield bracket towards the right side of the baler, and then back to the tank. When routing the hose avoid moving parts. A parts breakdown of the 4499C install kit is shown in the back of this manual.

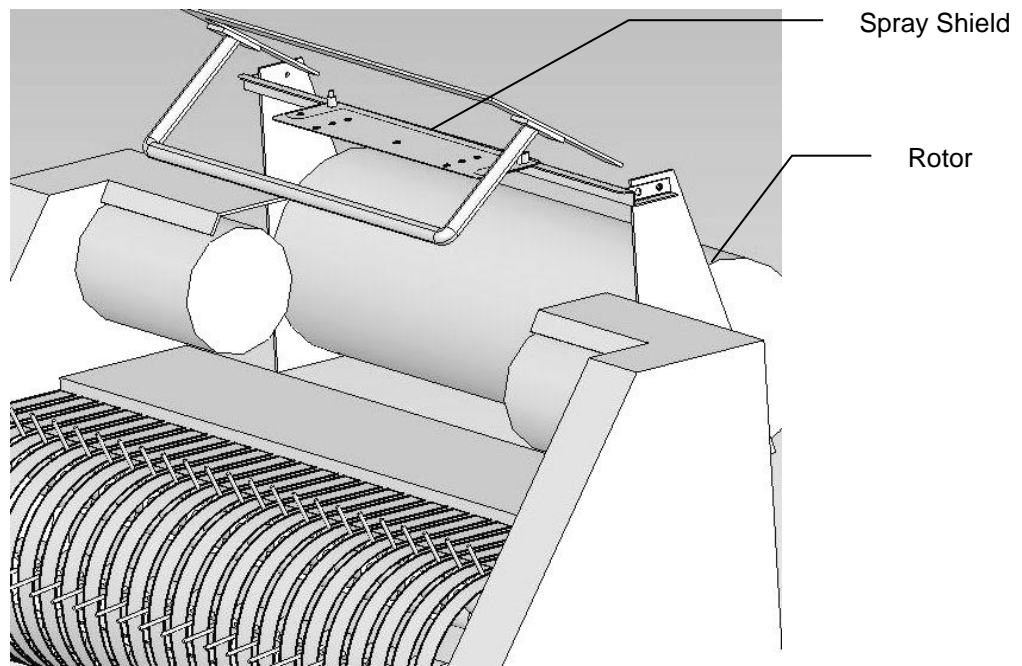

Installation Kit 4500C

Locate the sheet metal above the top auger. Locate the two holes through the sheet metal nearest the center of the pickup head. Place two 3/8" x 1-1/4" bolts through the sheet metal with the bolt heads on the bottom side. Place 001-4436CR over the bolts and fasten with 3/8" nuts, locks, and flat washers. Repeat for 001-4436CL on left side of machine. Place spray shield between brackets and tighten hardware. A parts breakdown of the 4500C install kit is shown in the back of this manual.

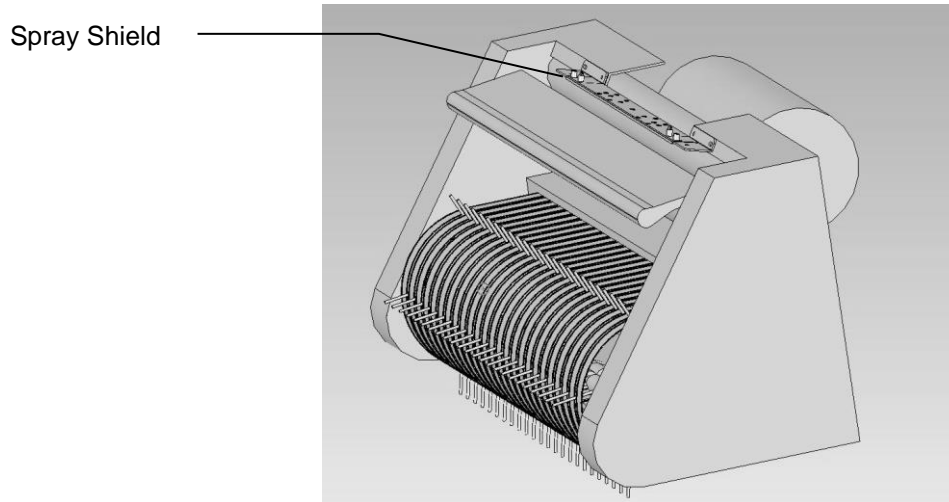

Installation Kit 4501C

4790 cutter balers with top auger. (Figure 1)

Locate the sheet metal above the top auger. Locate the two holes through the sheet metal nearest the center of the pickup head. Place two 3/8" x 1-1/4" bolts through the sheet metal with the bolt heads on the bottom side. Place 001-4436CR over the bolts and fasten with 3/8" nuts, locks, and flat washers. Repeat for 001-4436CL on left side of machine. Place spray shield between brackets and tighten hardware. A parts breakdown of the 4501C install kit is shown in the back of this manual.

4790 cutter balers without top auger. (Figure 2)

Connect spray shield to 001-4436CR and 001-4436CL brackets. Place the assembly across the top of the pickup head so the spray shield is horizontal. Center the shield over the throat of the baler directly above and centered over the bottom augers. Mark the holes on both sides and drill two 7/16" (12mm) holes on each side. Place two 3/8" x 1-1/4" through the sheet metal bolt heads down. Secure the assembly with 3/8" nut, locks, and flat washers. A parts breakdown of the 4501C install kit is shown in the back of this manual.

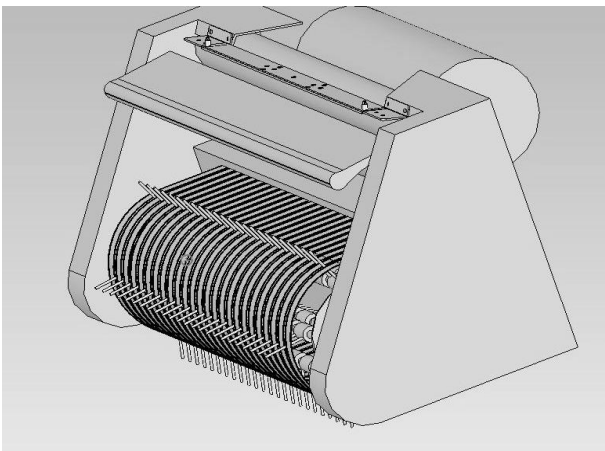

Figure 1

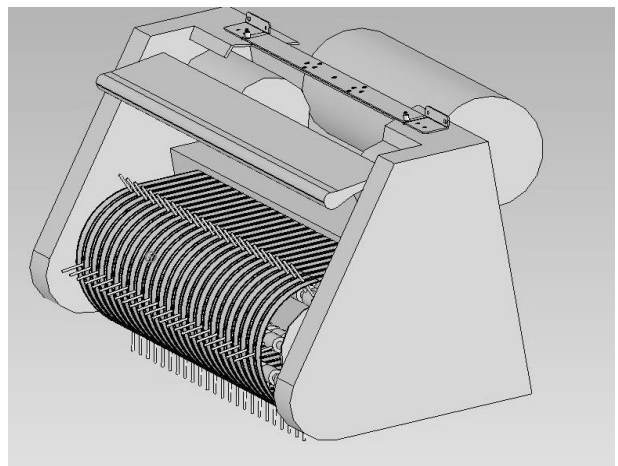
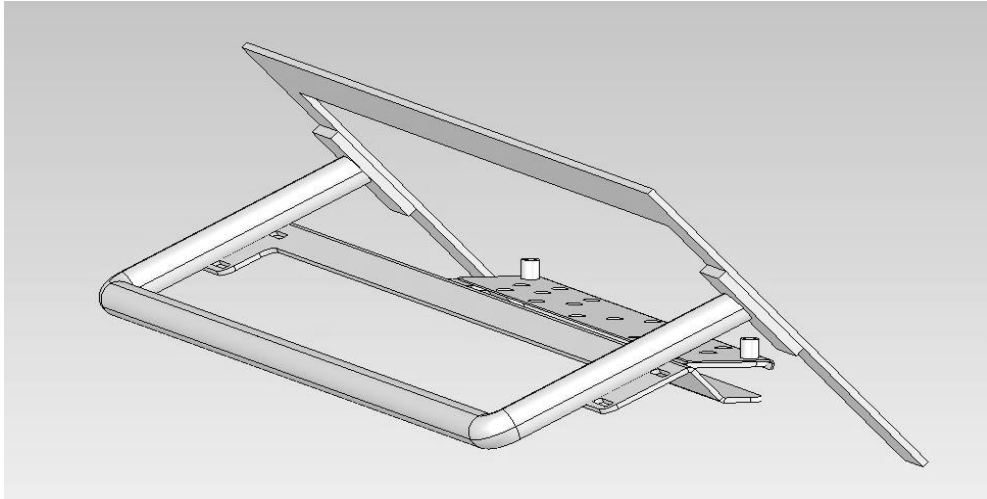

Figure 2

Installation Kit 4509C



Locate the curved tube above the auger and rotary cutting system. Attach Shield holder (001-4440A) using the four supplied U-bolts, nuts, flat and lock washers. Slide shield back as far as the baler will allow and tighten down all mounting hardware. Install spray shield (001-4810) and use the two lynch pins (008-4576) to secure. A parts breakdown of the 4509C install kit is shown in the back of this manual.

Installation Kit 4510C

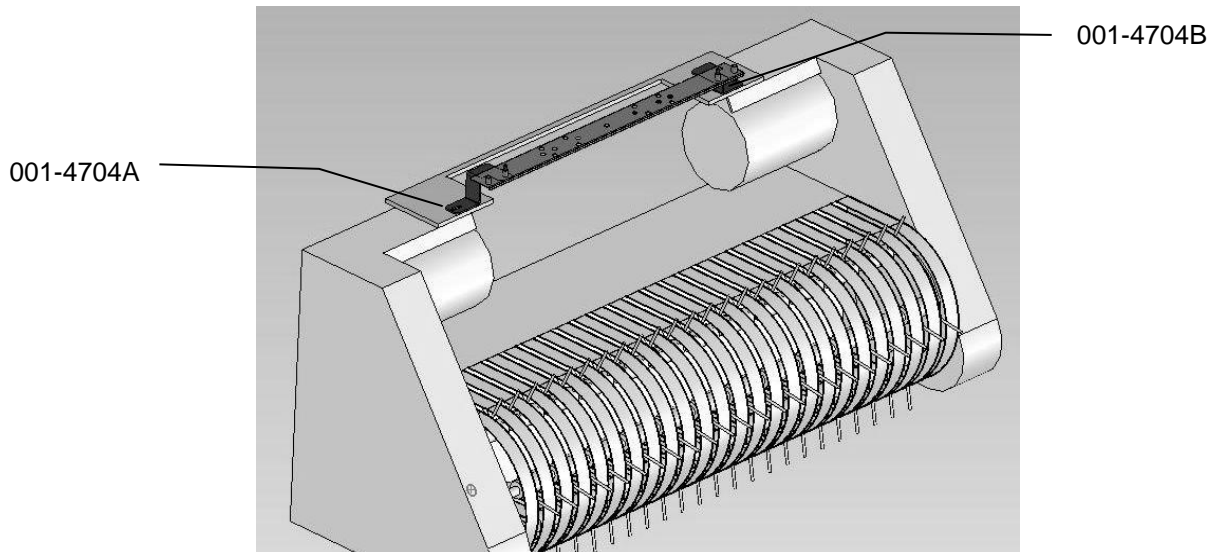

Locate the sheet metal above the pickup head. Connect spray shield to 001-4704A and 001-4704B brackets. Place the assembly across the top of the pickup head so the spray shield is horizontal. Center the shield over the throat of the baler directly above and centered over the bottom augers. Mark the holes on both sides and drill two 7/16" (12mm) holes on each side. Place two 3/8" x 1-1/4" through the sheet metal bolt heads down. Secure the assembly with 3/8" nut, locks, and flat washers. A parts breakdown of the 4510C install kit is shown in the back of this manual.

Installation Kit 4511C

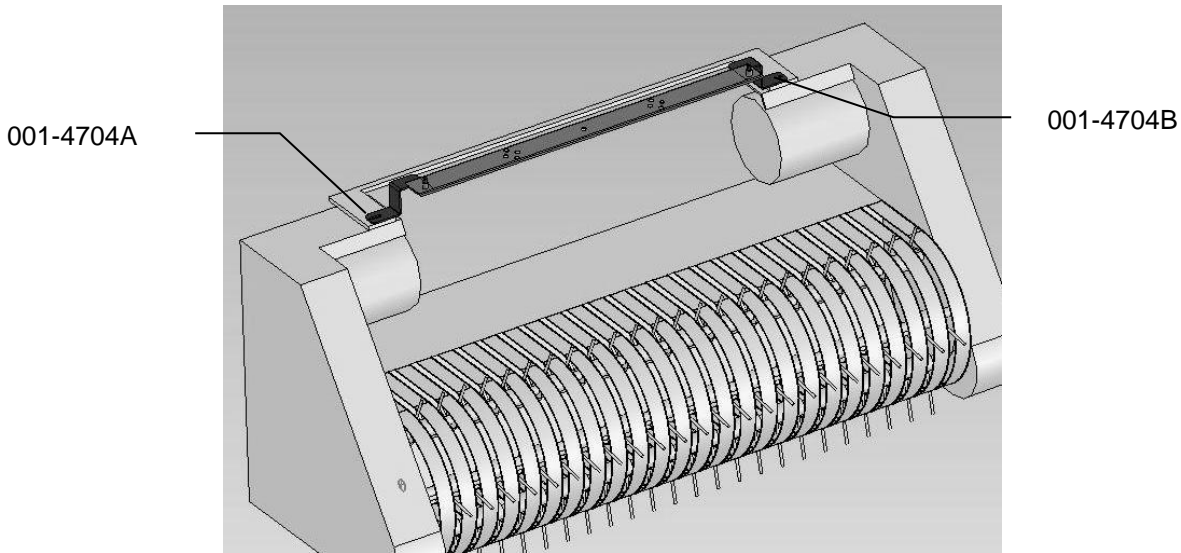

Locate the sheet metal above the pickup head. Connect spray shield to 001-4704A and 001-4704B brackets. Place the assembly across the top of the pickup head so the spray shield is horizontal. Center the shield over the throat of the baler directly above and centered over the bottom augers. Mark the holes on both sides and drill two 7/16" (12mm) holes on each side. Place two 3/8" x 1-1/4" through the sheet metal bolt heads down. Secure the assembly with 3/8" nut, locks, and flat washers. A parts break down of the 4511C install kit is shown in the back of this manual.

Installation Kit 4514C

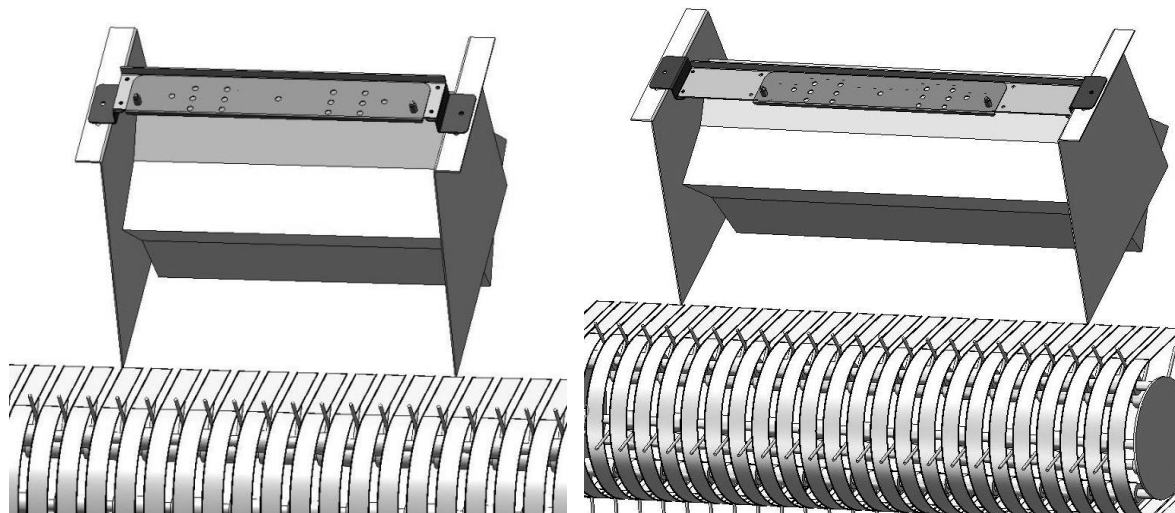

3 Foot Baler

4 Foot Baler

Locate the two mounting brackets (001-4431KB). In the 4' baler, these brackets are positioned so the spray shield is dropped down from the flywheel. On the 3' baler, these brackets are positioned using the top hole on each side to raise the spray shield up from the rotor. Use the top hole on the baler for mounting the brackets. These brackets will be secured with two 3/8" x 1" bolt and flats, locks, and nuts. Then the spray shield holder (001-4431KA) spans across the throat of the baler and bolts to mounting brackets so the pins are on the top side. The holder has a formed flange on the backside that should be flush with the back of the mounting brackets. The shield holder will be fastened to the mounting brackets with four 5/16x1" bolts with flats, locks and nuts (2 on each side). In the case of the 3' (1M) balers, there are additional holes for mounting the holder to the brackets. For 3' (1M) wide balers 7-1/2" (19cm) will need to be cut off the ends the shield holder. Place the spray shield assembly on top of the shield holder and secure with lynch pins.

Installation Kit 4515C

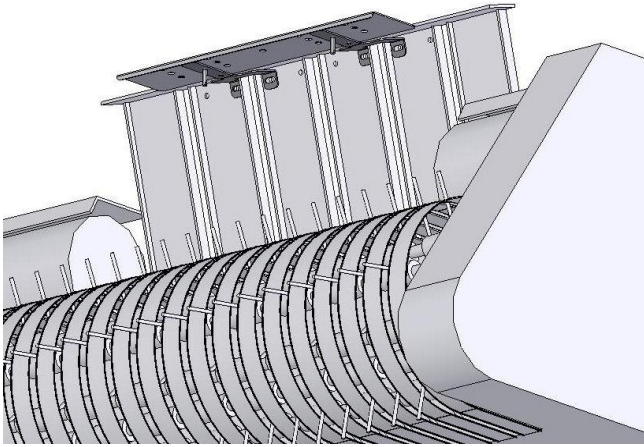

Non-HDP balers

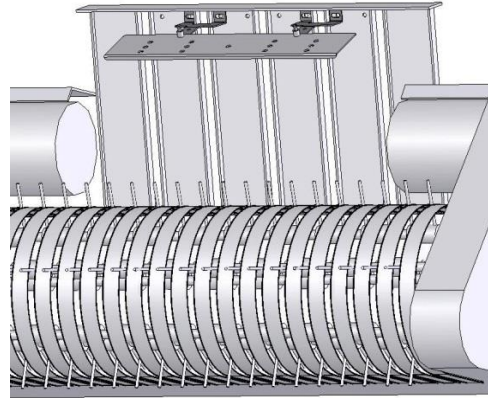

All HDP balers

Locate the four center stuffer guards (on narrower models of baler, there may be only four stuffer guards). Remove the nuts and bolts indicated above that fasten the stuffer guards to the cross member above the baler throat. Replace the hardware that you removed with the hardware included in the parts bag (M10x30 bolts, M10 lock washers, and M10 nuts) and bolt the spray shield holder (001-4435KS in place as shown above. Use the above pictures to determine the position of the spray shield holder depending on baler type. Position the spray shield (001-4435AS) on top of the spray shield holders with the pins from the spray shield holder extending through the pipes welded to the spray shield. Adjust the spray tips so they point towards the throat of the baler. Adjust the spacing of the spray shield holder as needed and tighten the hardware.

Installation Kit 4525C

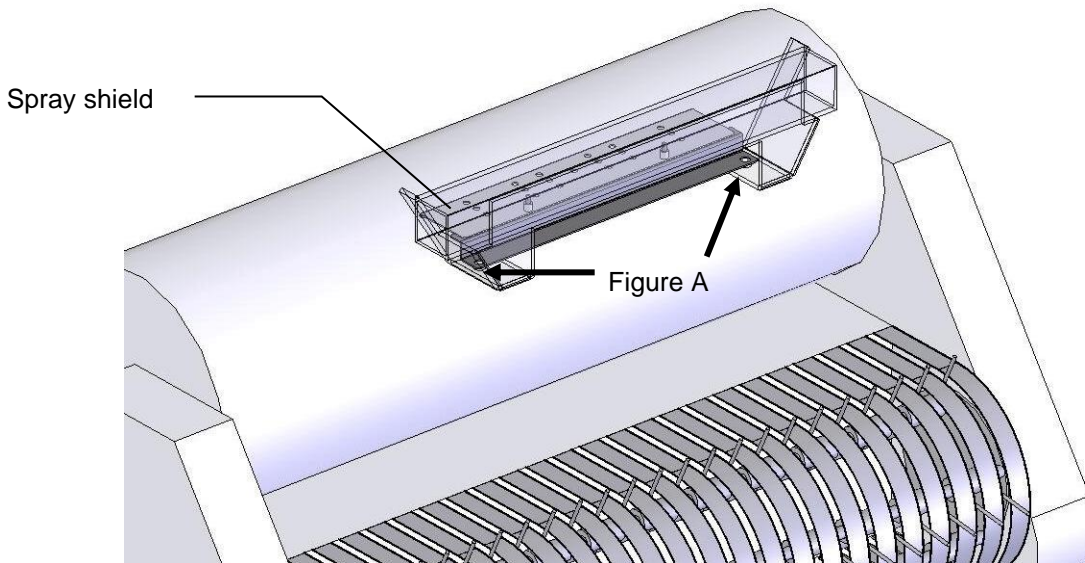

Locate the two bolts show in Figure A. Remove bolts and install spray shield holder (001-4435EK). Install bolts and tighten. Install spray shield assembly (001-4435ES) and secure with two supplied lynch pins. Use the inside slots on 3x3 balers and the outside slots on 3x4 balers.

Installation Kit 4537C

The spray shield holder (001-4435L) is centered on the L-shaped bracket above the rotor and secured with 3/8"x1-1/4" hex bolts, 3/8" lock washers, and 3/8" nuts (x3). The spray shield is then pinned in place with the lynch pins. Route hoses so they do not interfere with moving parts, and do not fasten hoses to hydraulic lines.

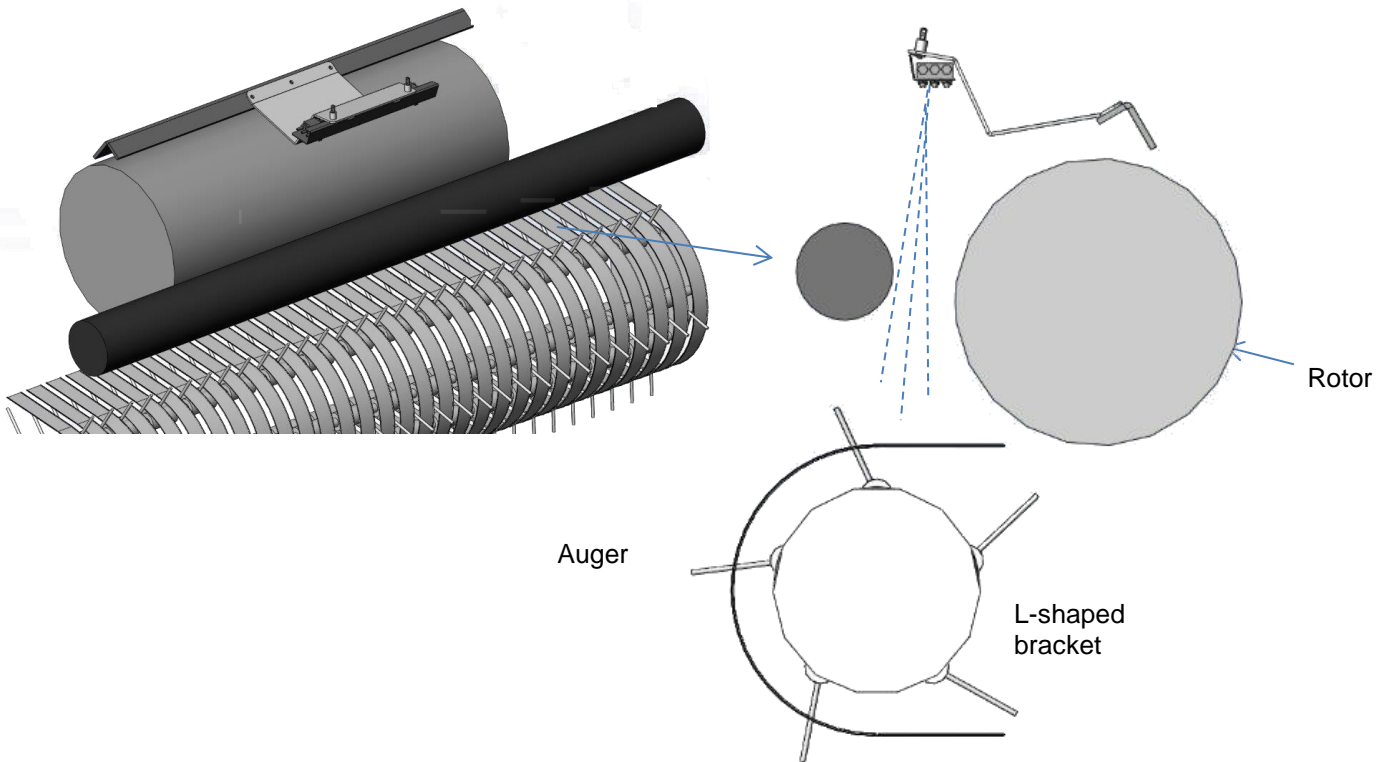

Installation Kit 4539C

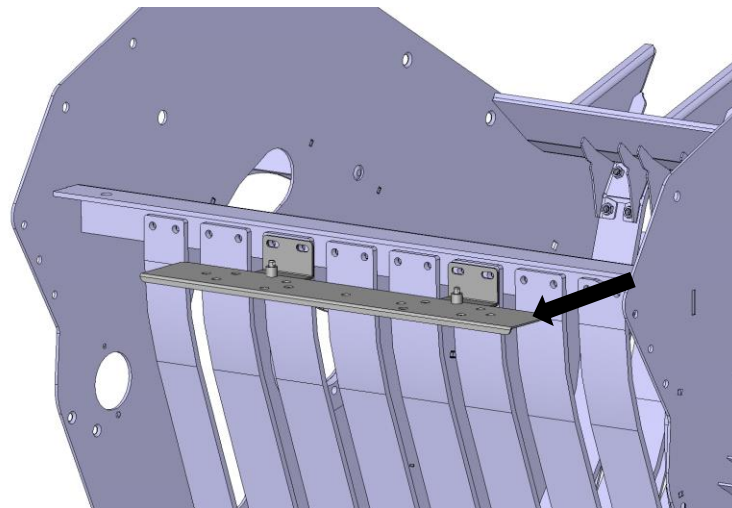

Locate the center stuffer guards and remove the nuts and bolts indicated above that fasten the stuffer guards to the cross member above the baler throat. Replace the hardware that you removed with the hardware included in the parts bag (M10x30 bolts, M10 lock washers, and M10 nuts) and bolt the spray shield holder (001-4435KX) in place as shown above. Use the above pictures to determine the position of the spray shield holder depending on baler type. Position the spray shield (001-4435AS) on top of the spray shield holders with the pins from the spray shield holder extending through the pipes welded to the spray shield. Adjust the spray tips so they point towards the throat of the baler

Installation Kit 4540C – Krone 3' HDP, HS, XC Balers

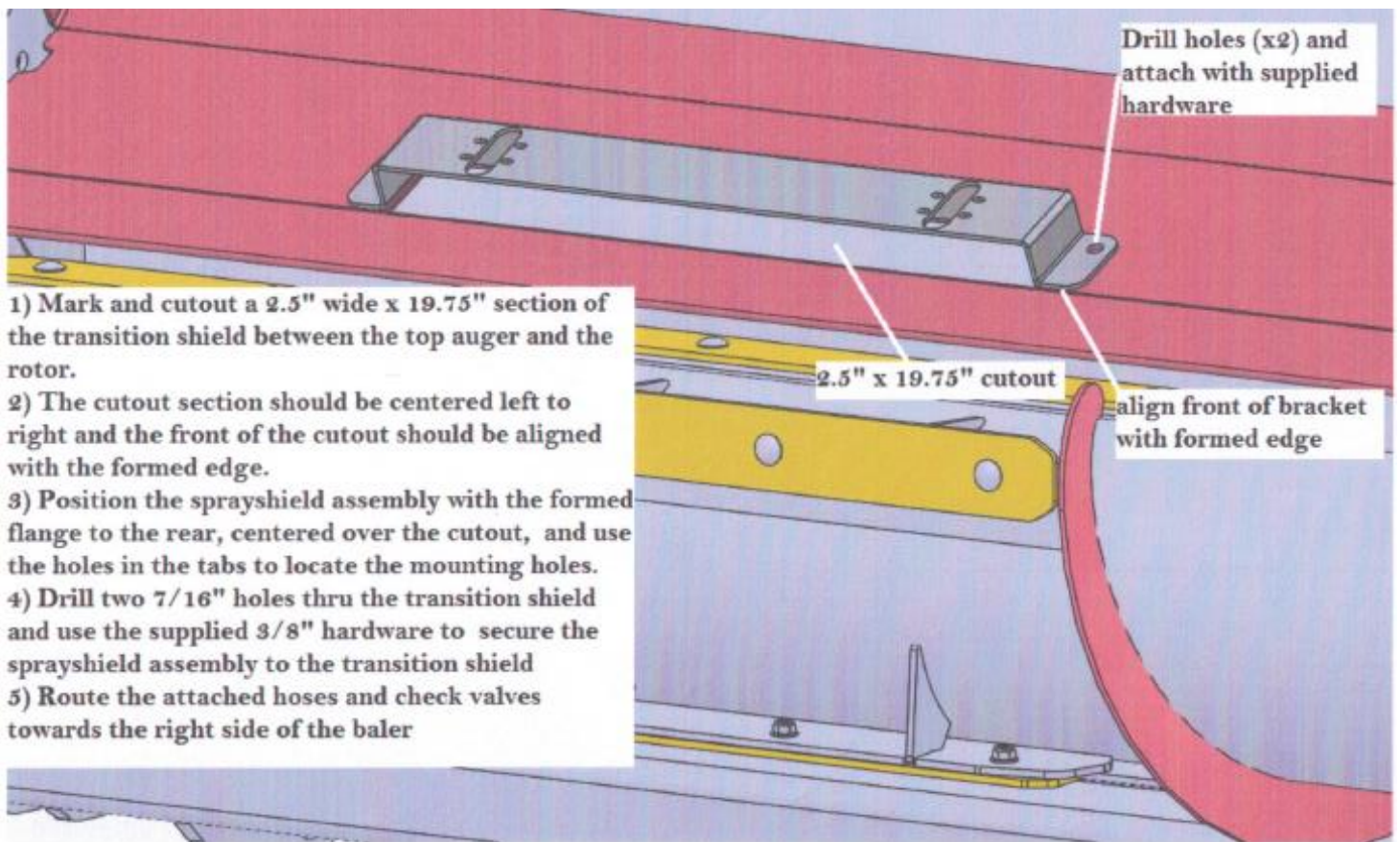

Locate nozzle bracket 001-4435NKS. Center the bracket on the top of the rotor shield and aligned with formed edge. Mark and cut out a 2 1/2" x 19 3/4" (64mm x 47cm) section of the transition shield between the top auger and the rotor. The cutout section should be centered left to right and the front of the cutout should be aligned with the formed edge.

Position the spray shield assembly with the formed flanged to the rear, centered over the cutout, and use the holes in the tabs to locate the mounting holes. Drill two 7/16" (11mm) holes through the transition shield and use the supplied 3/8" (10mm) hardware to secure the spray shield assembly to the transition shield. Route the attached hoses and check valves towards the right side of the baler.

Installation Kit 4541C – Krone 4' HDP, HS, XC Balers

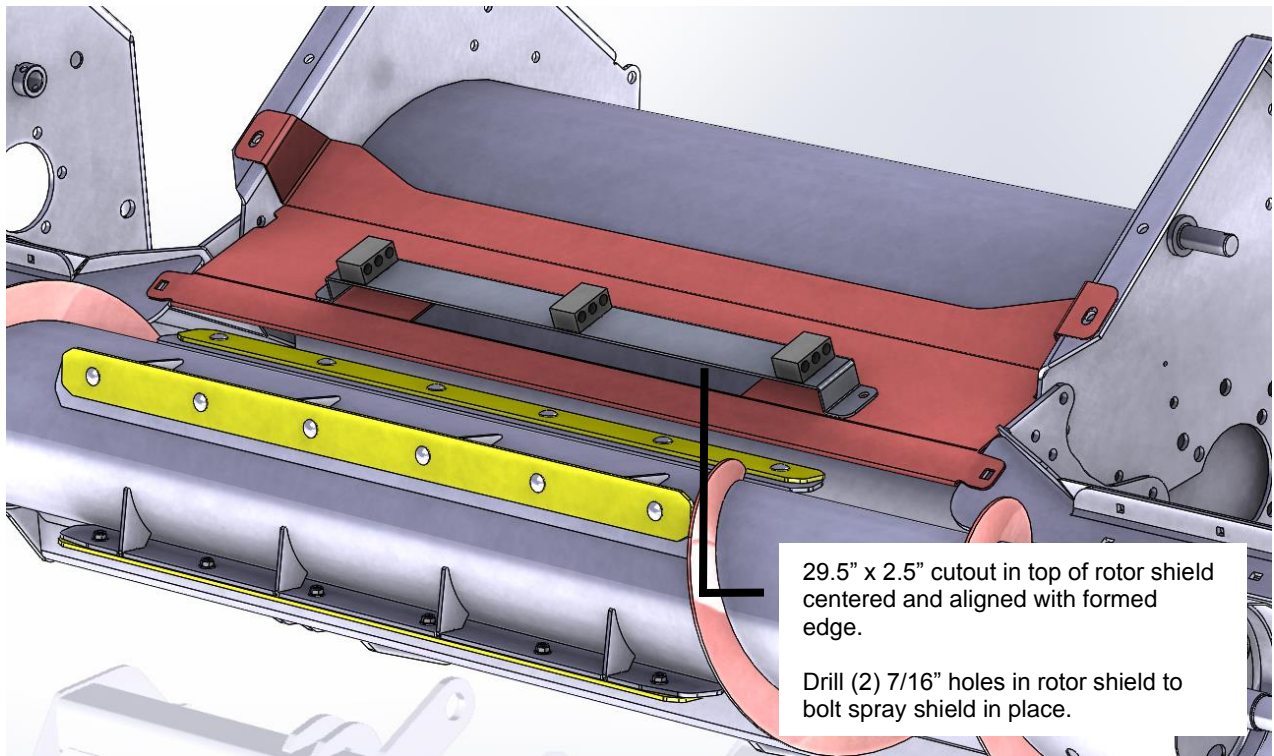

Locate nozzle bracket 001-4435NK. Center the bracket on the top of the rotor shield and aligned with formed edge. Mark and cut out a 2 1/2" x 19 3/4" (64mm x 47cm) section of the transition shield between the top auger and the rotor. The cutout section should be centered left to right and the front of the cutout should be aligned with the formed edge.

Position the spray shield assembly with the formed flanged to the rear, centered over the cutout, and use the holes in the tabs to locate the mounting holes. Drill two 7/16" (11mm) holes through the transition shield and use the supplied 3/8" (10mm) hardware to secure the spray shield assembly to the transition shield. Route the attached hoses and check valves towards the right side of the baler.

Installation of Solenoids and hose routing



- A. Once spray shield is mounted, ensure solenoids 002-2203F are mounted using the solenoid mount plate 001-4648DSH as close as possible (max distance 3ft) to the spray shield. This will ensure the most precise application of the preservative.

Solenoids
002-2203F



Solenoid Harness
006-3650-S1



Solenoid Mount
001-4648DSH

- B. Once solenoids are mounted, streamline solenoid harness 006-3650-S1 along baler back to connection on main baler harness 006-765B or 006-765B2 once installed. Solenoid with white dot attaches to SOL 1 and Solenoid with blue dot attaches to SOL 2. Connect harnesses and ensure they are secure.
- C. Route $\frac{1}{2}$ " hose along the path or similar, inside of the baler from the pump plate to the solenoid plate, as shown in picture above. Keep hoses away from moving parts and hydraulic hoses. When all hose connections are made to the tank, pump, solenoids, and spray shield secure with existing cable clamps or use cable ties.
- D. Connect $\frac{1}{4}$ " reinforced hoses from spray shield to solenoids. Note: Make sure solenoid with white dot attaches to spray shield with white dot. Follow same procedure for Blue dot.

Installation of Main Wire Harness Routing and Connections



Route harness 006-765B or 006-765B2 along this path or similar on top of or inside of the baler from the pump plate to the hitch of the baler. Note: the end of the harness that has the large plug with sockets and the white heat shrink label, will be at the hitch of the baler. The other end attaches to plug on pump plate. Keep harnesses away from moving parts and hydraulic hoses.

Identification on plugs on (006-765B or 006-765B2)

Sol 1 and Sol 2. Plugs. These attach to the solenoids with two 006-3650-S1 harness. Sol 1 attaches to the solenoid with a white dot. Sol 2 attaches to the solenoid with a blue dot.

EOR Plug (end of row) is for the “Optional” crop eye kit. (474C)

CAN/IDM Plugs are for use with “Optional” Moisture Dye Marking kit. (740DM), ISOBUS integration with compatible balers, future expansion, or CAN termination.

EOB Plug is for the (end of bale) sensor that is attached by the needle arm.

Secure with existing cable clamps or use cable ties when all connections are made.

Installation of Star Wheel Moisture Sensors

1. Locate the two-star wheel moisture sensors (030-4642U / UE) and twine diverters (001-4644 / 4645)
2. The star wheels will be placed as close to the knotter as possible. Refer to the following pages for your exact make and model installation instructions.
3. Install the four (two per side) 5/16” x 3” Allen head cap screws. Make sure the Allen heads are in the bale chamber.
4. The star wheel with the 6-position plug will need to be placed on the right side of the baler along with the twine diverter with two extra holes.
5. The star wheel with the 2-position plug will need to be placed on the left, or ladder side of the baler
6. Secure the star wheels and twine diverters to baler with four 5/16” hex nuts and lock washers.
7. Connect moisture harness (006-7307EM2 or 006-7307EM3) to both star wheels.
8. Run other end of (006-7303EM2 or 006-7307EM3) along top of baler back to the pump module located on the tank saddle.
9. Attach rectangle plug to bottom of pump module.

The following pages will contain detailed instructions for specific baler makes and models.

New Holland 590 through BB9080 and Case IH LBX331 through LB433 Balers

Star Wheel Mounting - The star wheels are to be mounted on top of the baler, just behind the knotters and under the walkway on both sides. Remove the bale from the chute, tip the walkway up and locate the wheels on the top outside corner angles of the bale chute, one on each side. Some balers may already have the notch cut and square holes.

If so, the holes will need to be drilled round with a 5/16" drill bit, if not use the template located in the back of the manual as a guide for cutting the notch and mounting holes for the star wheels. Mark the location of the notch 5/8" wide and 9" long (16mm x 23cm) and the location of the two 5/16" (8mm) holes for the star wheel base. After cutting the notch and drilling the holes, insert the 5/16" x 3" x black allen head bolts up through the chute.

Place the star wheel block over the bolts and install the twine guards. Secure with 5/16" lock washers and nuts. The twine guard containing the extra two holes will be placed on the right side.

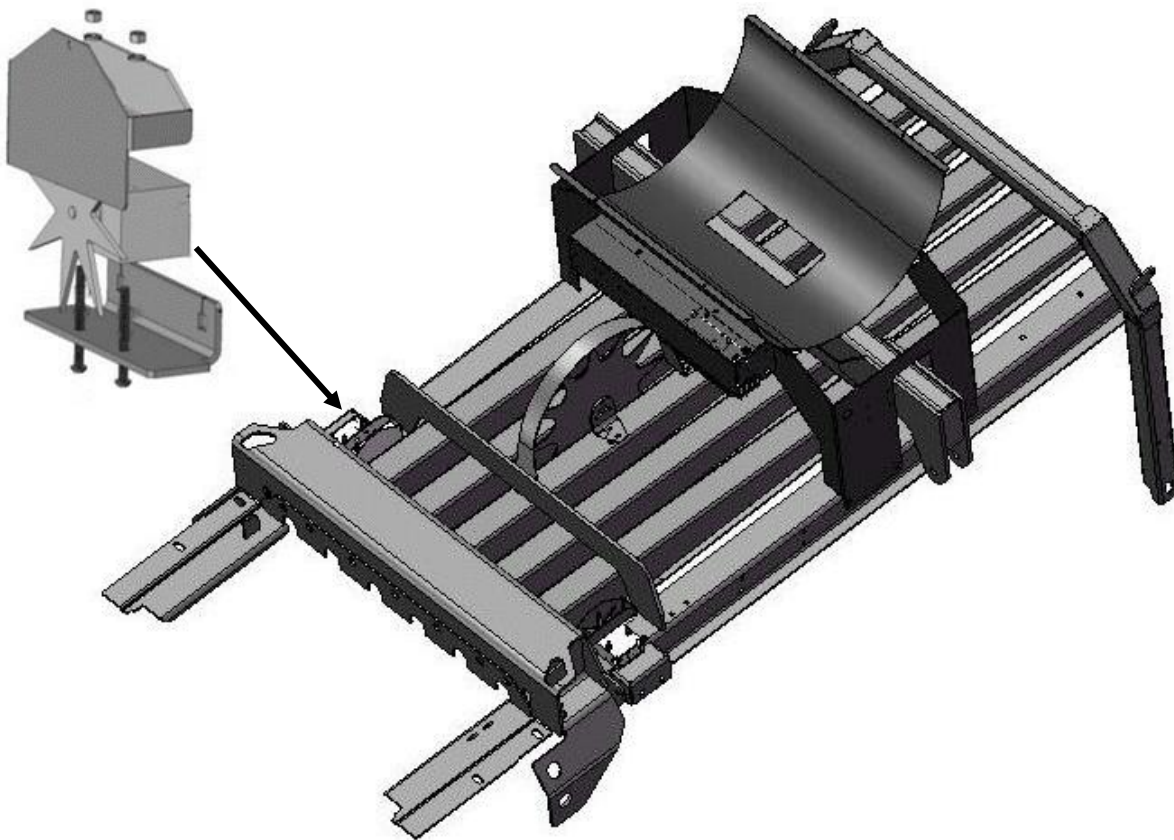

**Challenger LB33, LB34, Hesston 7430, 4750, 4755, 4760, 4790,
Massey Ferguson 2050, New Idea 7233, 7333, 7234**

Star Wheel Mounting – The star wheels are mounted under the walkway on top of the baler behind the knotters. Remove the bale from the chute and tip the walkway up. Locate the outside corner angles of the bale chute on the left and right side of the baler. The center of the wheel shaft will be approximately 5-1/2” (13cm) in front of the walkway support or about halfway between the walkway support and the cross frame almost directly in front of it. The notch will start just in front of the walkway support.

Two parts of the baler frame will have to be trimmed off on both sides to mount each star wheel. The first is the outside corner angles of the chute. Use the template to mark the location of the star wheel notch as well as the location of the two holes for the star wheel base. The notch will be 5/8” by 9” (16mm x 23cm) long and will help keep the wheel away from the twine. Spray the ground off areas with touch up paint to prevent rusting. The second portion of the baler to trim off is the end of the gusset that may interfere with the star wheel’s plastic base support. Center the star wheel in the slots that was just notched and check for interference with the gusset.

Drill 5/16” (8mm) holes for the star wheel block. Insert the 5/16” x 3” bolts up through the chute. Place the star wheel block over the nuts and install the twine guards. Secure with 5/16” Lock washers and nuts. **The twine guard containing the two extra holes will be placed on the right side of the baler.**

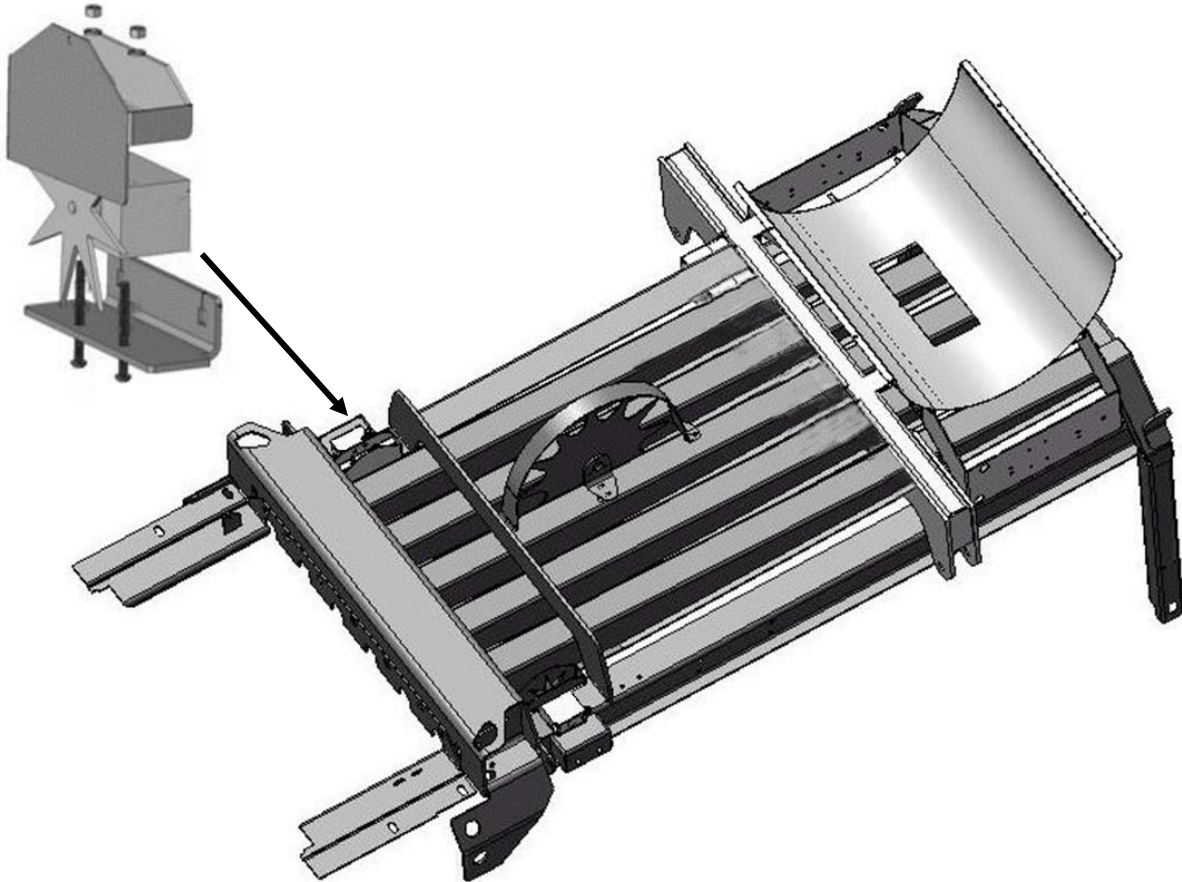

Hesston 4900, 4910, Challenger LB44, and New Idea 7244

Star Wheel Mounting –The star wheels are mounted on top of the baler, just behind the knotters under the walkway on both sides. Use the template at the back of the manual to mark the location and dimension of the notch and holes. Remove the bale from the chute. Tip the walkway up and locate the wheels on the top outside corner angles of the bale chute, one on each side. The star wheel block is located just in front of the horizontal channels holding the twine boxes. Using the template, mark the location of the notch (5/8" wide and 9" long) and the location of the two 5/16" (8mm) holes for the star wheelbase using a center punch. Any bare metal edge of the angle should be sprayed with touch up paint to prevent corrosion.

Once the above modification to the baler is made on both sides of the chute, the wheels can be mounted. Insert the 5/16" x 3" bolts up through the chute and use nuts to hold the bolts in place. Place the star wheel block over bolts and install the twine guards on the star wheel block. **The twine guard containing the two extra holes will be on the right side of the baler.**

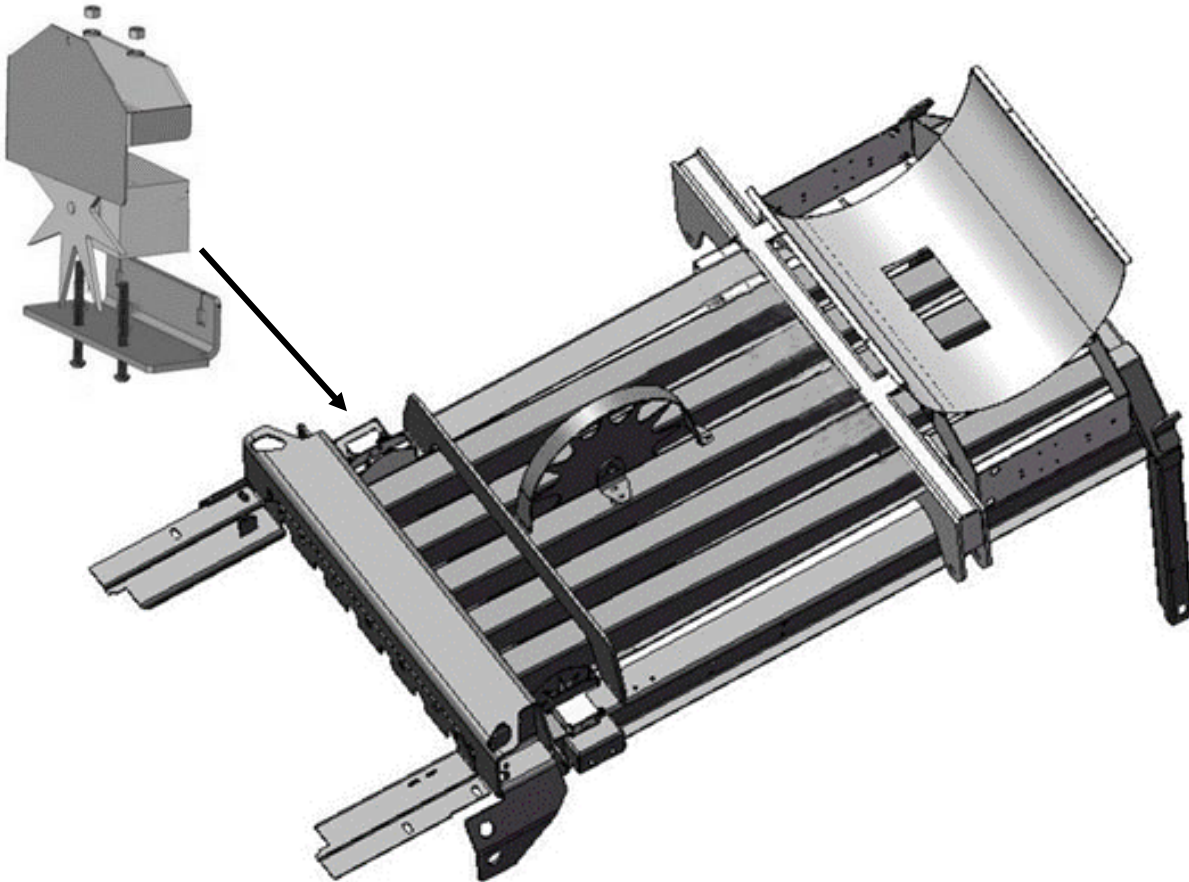

Claas 2100 and 2200

Star Wheel Mounting – The star wheels are to be mounted on top of the baler, just behind the knotters and as far forward as possible. Remove the bale from the chute. Locate the wheels on the top outside corner angles of the bale chute, one on each side. Use the template located in the back of the manual as a guide for cutting the notch and mounting holes for the star wheels.

Mark the location of the notch 5/8" wide and 9" long (16mm x 23cm) and the location of the two 5/16" (8mm) holes for the star wheel base. After cutting the notch and drilling the hole, insert the 5/16" x 3" black Allen head bolts up through the chute. Place the star wheel block over the bolts and install the twine guards. Secure with 5/16" lock washers and nuts. **The twine guard containing the extra two holes will be placed on the right side.**

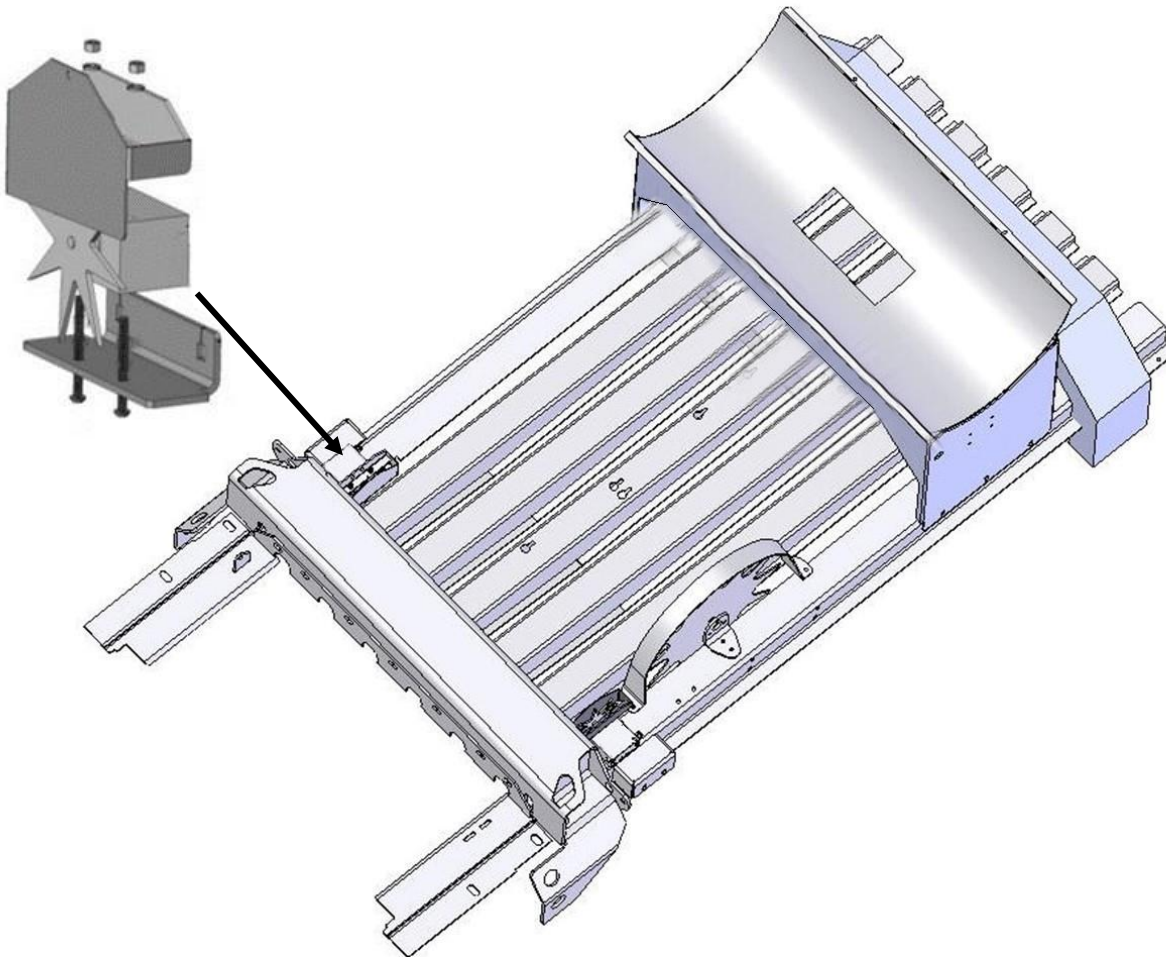

Claas 3200-3400, 5300 Large Square Balers continued

Star Wheel Mounting – Use the picture below as a guide for drilling the mounting holes for the star wheels. The star wheels are to be mounted on the side of the bale chamber, between the top and middle channel. Measure 10" back from the hinge between the top and middle channel. Use the template located in the back of the manual as a guide for cutting the notch and mounting holes for the star wheels. Cut 1" x 9" (25mm x 23cm) slot for the star wheel. Make sure the wheel is square.

Mark the location of the two 5/16" holes for the star wheel base. After drilling the holes, insert the 5/16" x 3" allen head bolts through the chute. Place the star wheel block over the bolts and install twine guards on the star wheel. Secure with 5/16" lock washers and nuts. **The twine guard containing the extra two holes will be placed on the right side.**



Krone Large Square

Star Wheel Mounting-non-HDP models remove the bale for the bale chute. The star wheels are to be mounted on top of the baler, just behind the knotters and as far forward as possible. Use the table and diagram below to mark the two bolt hole locations on the bale chamber (D,E,F). Use the template in the back of the manual to mark the location of the notch to be cut. When cutting the notch both the vertical brace and the bale chamber will need to be cut.

Before cutting verify the notch measurement with the below diagram using marks A & B. After cutting the notch and drilling the holes, insert the 5/16" x 3" black Allen head bolts up through the chute. Place the star wheel block over the bolts and install the twine guards. Secure with 5/16" lock washers and nuts. **The twine guard containing the two extra holes will be placed on the right side.**

For 2010 Krone HDP part number 20 073 194 0 must be ordered. This kit will include mounting instructions for the star wheels.

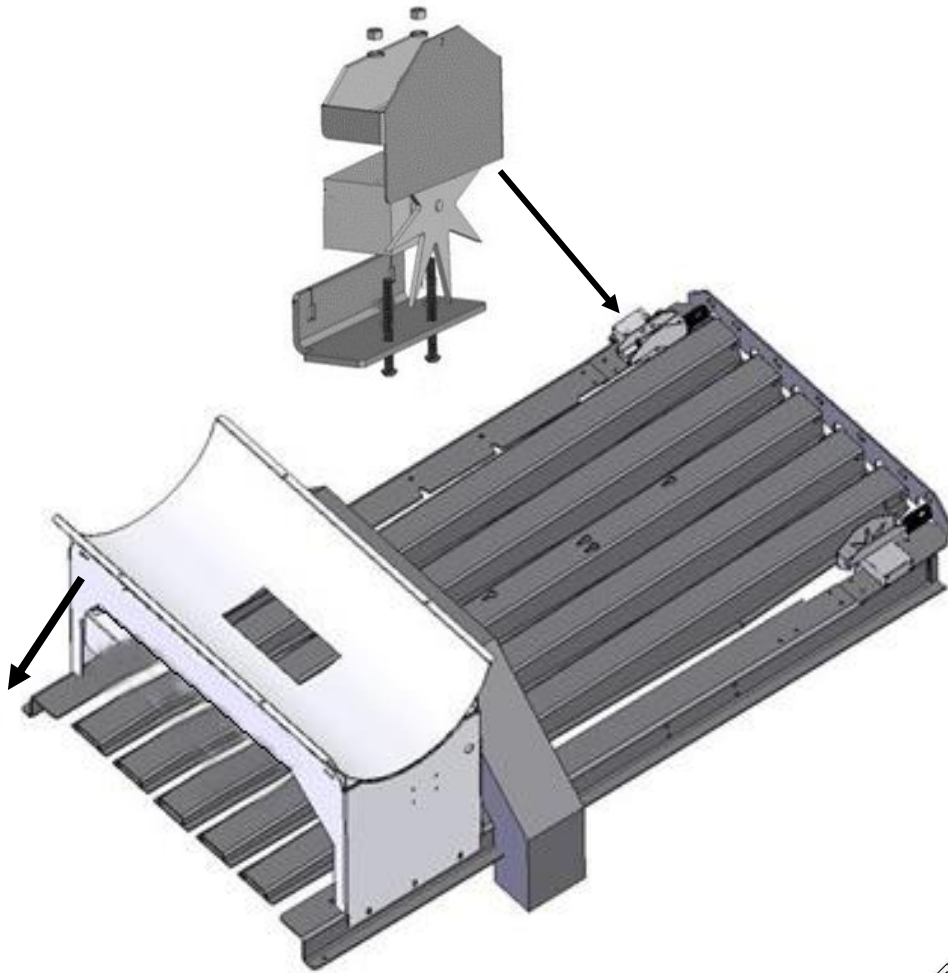

Krone balers 890 – 12130

A= 2-3/4" (69mm) from edge of notch

B= 3-1/2" (89mm)

D= 3" (76mm)

E= 5-3/4" (77mm) from edge of notch

F= 8-3/4" (22cm) from edge of notch

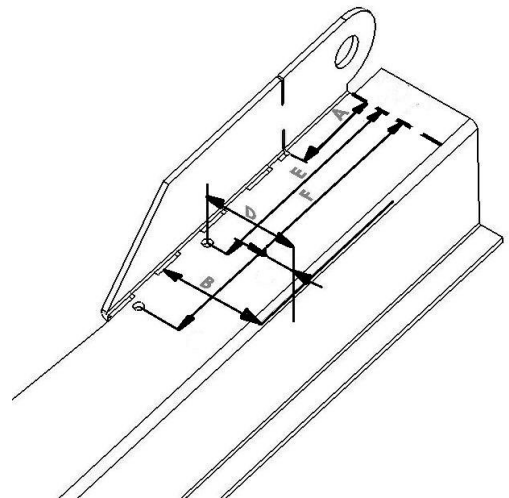

Kuhn LSB 870 – 1290, Vicon LB 8200 and LB 12200, Taarup 6570 – 6690 OC

Star Wheel Mounting- The star wheels are to be mounted on top of the baler, just behind the knotters and under the walkway on both sides. Remove the bale from the chute, mount the star wheels flush with the back of the walkway with one star wheel on each side.

Use the template in the back of the manual labeled Vicon large square balers for this installation. Mark the holes inside the chamber, and drill the two holes per side, for mounting from inside the chamber. Insert the 5/16" x 3" black Allen head bolts up through the chute. Place the star wheel block over the bolts and install the twine guards. Secure with 5/16" lock washers and nuts. **The twine guard containing the two extra holes will be placed on the right side.**

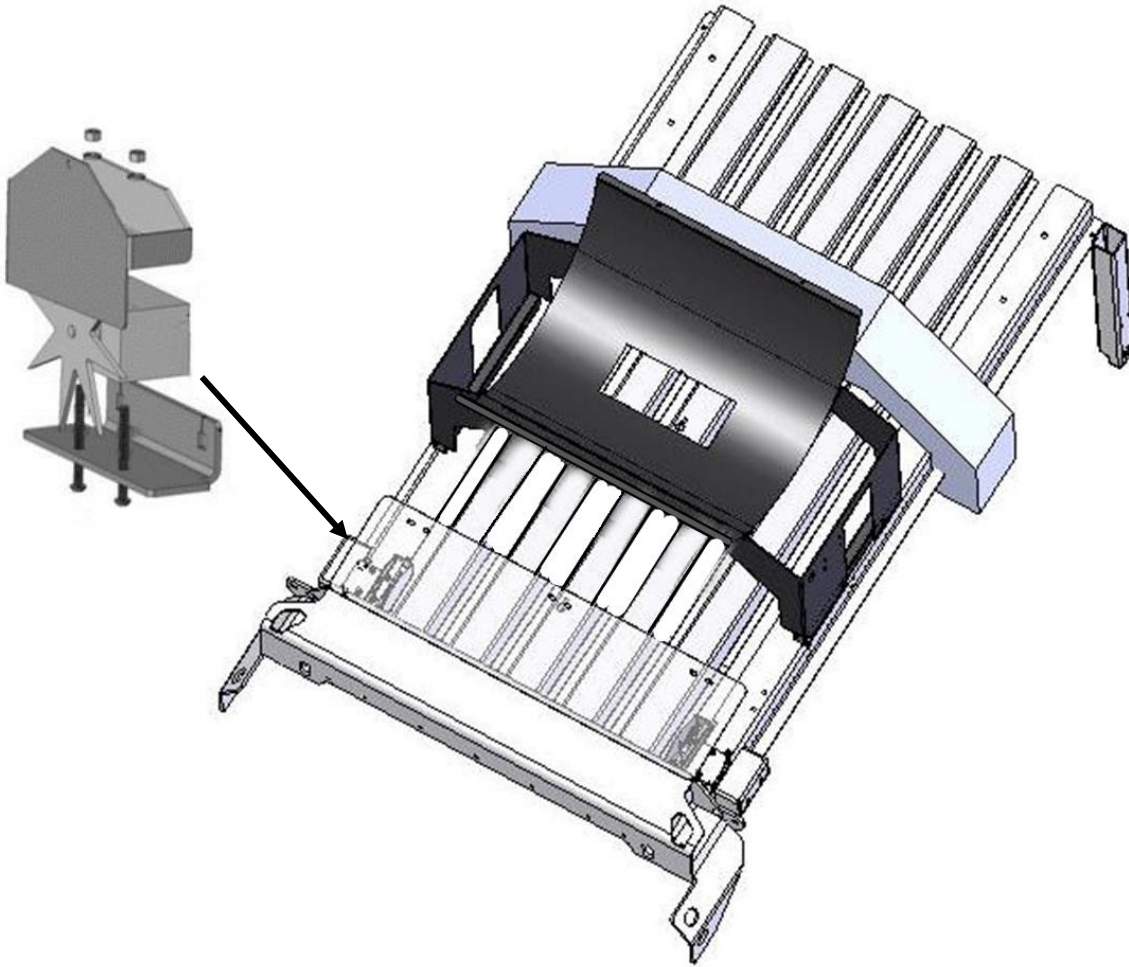

Installation of End of Bale Sensor

The end of bale sensor determines the position of the needles on the baler. When the needles cycle the sensor communicates this information to the controls. This information is used for job records and will be used by the optional Bale Identification System. Follow the steps below for your baler to mount the sensor.

All AGCO Hesston 4760 – 4790 and equivalents, Case IH LBX 331 – LB 433, Class 2100, John Deere 100, New Holland 590 – BB 9080

End of bale sensor bracket (001-4648) will be used. Cutoff excess metal not used during installation.

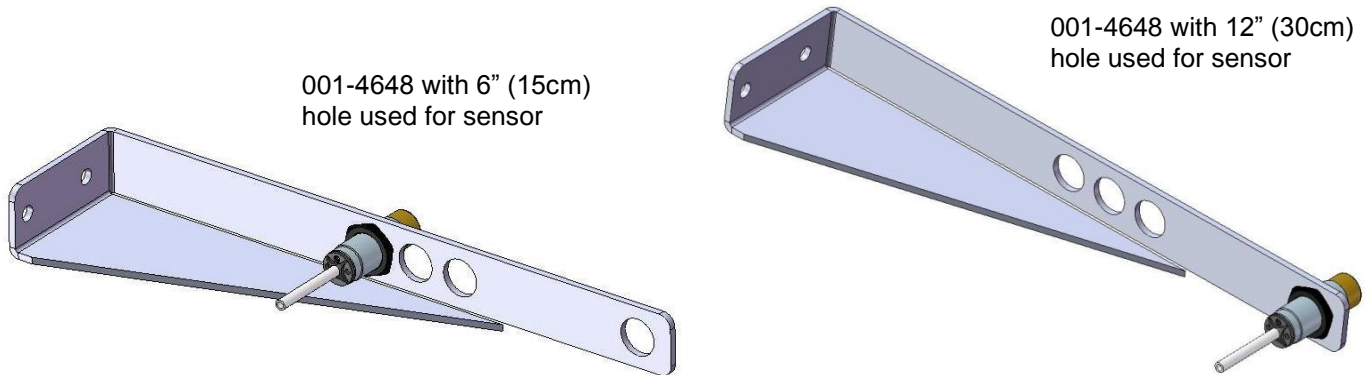

All Hesston 4750 – 4755 & 4900 – 4910

End of bale sensor bracket (001-4648) and Hesston end of bale mount (001-4648H) will be used. The Hesston end of bale mount will be found in the installation kit box. Cutoff excess metal not used during installation.

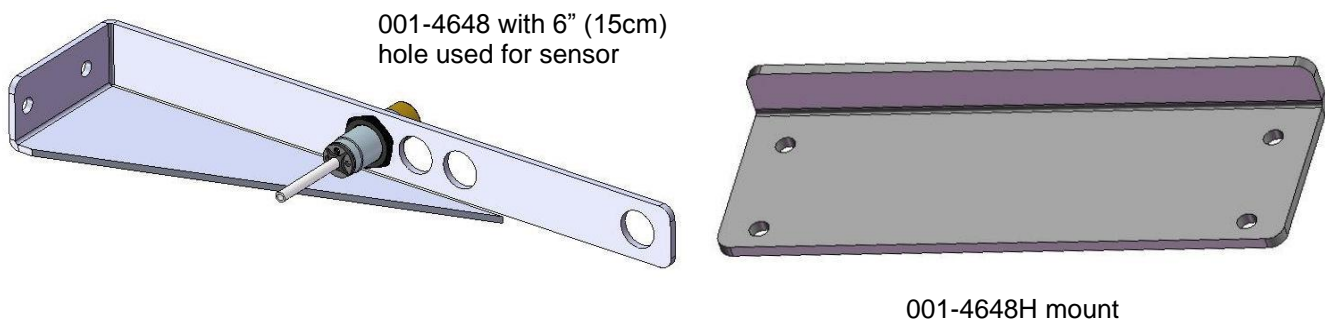

All Krone 890 – 12130

Krone end of bale sensor bracket (001-4648K or 001-4648K2) be used. The Krone end of bale mount will be found in the installation kit box. The 001-4648K will be used with balers 890 – 1290. The 001-4648K2 will be used with the 12130 balers.

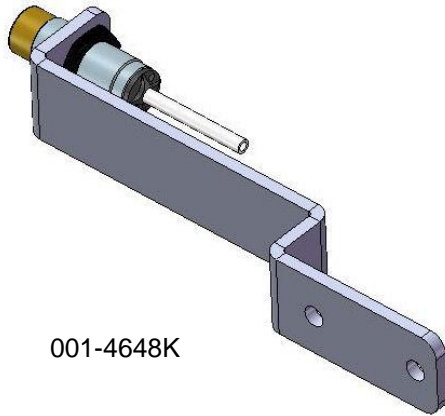

001-4648K

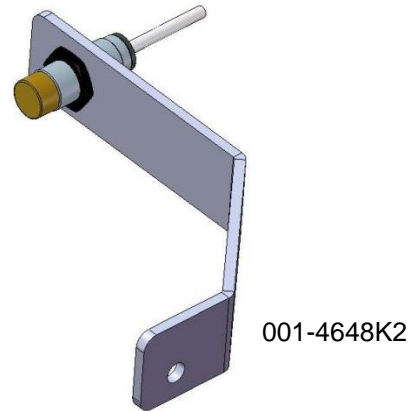

001-4648K2

All Kuhn, Vicon and Taarup Balers

End of bale sensor bracket (001-4648) will be used. Cutoff excess metal not used during installation.

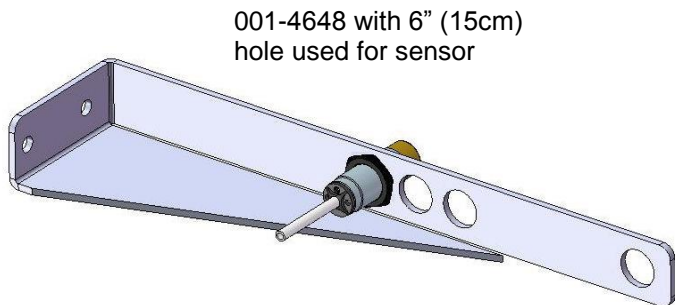

001-4648 with 6" (15cm)
hole used for sensor

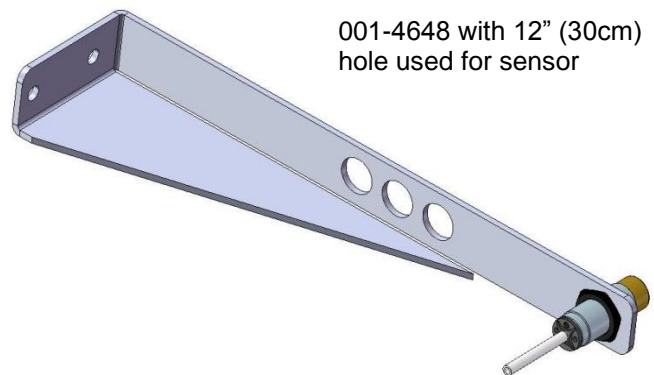

001-4648 with 12" (30cm)
hole used for sensor

End of Bale Sensor Bracket Installation

Hesston 4750-4755 and 4900 – 4910

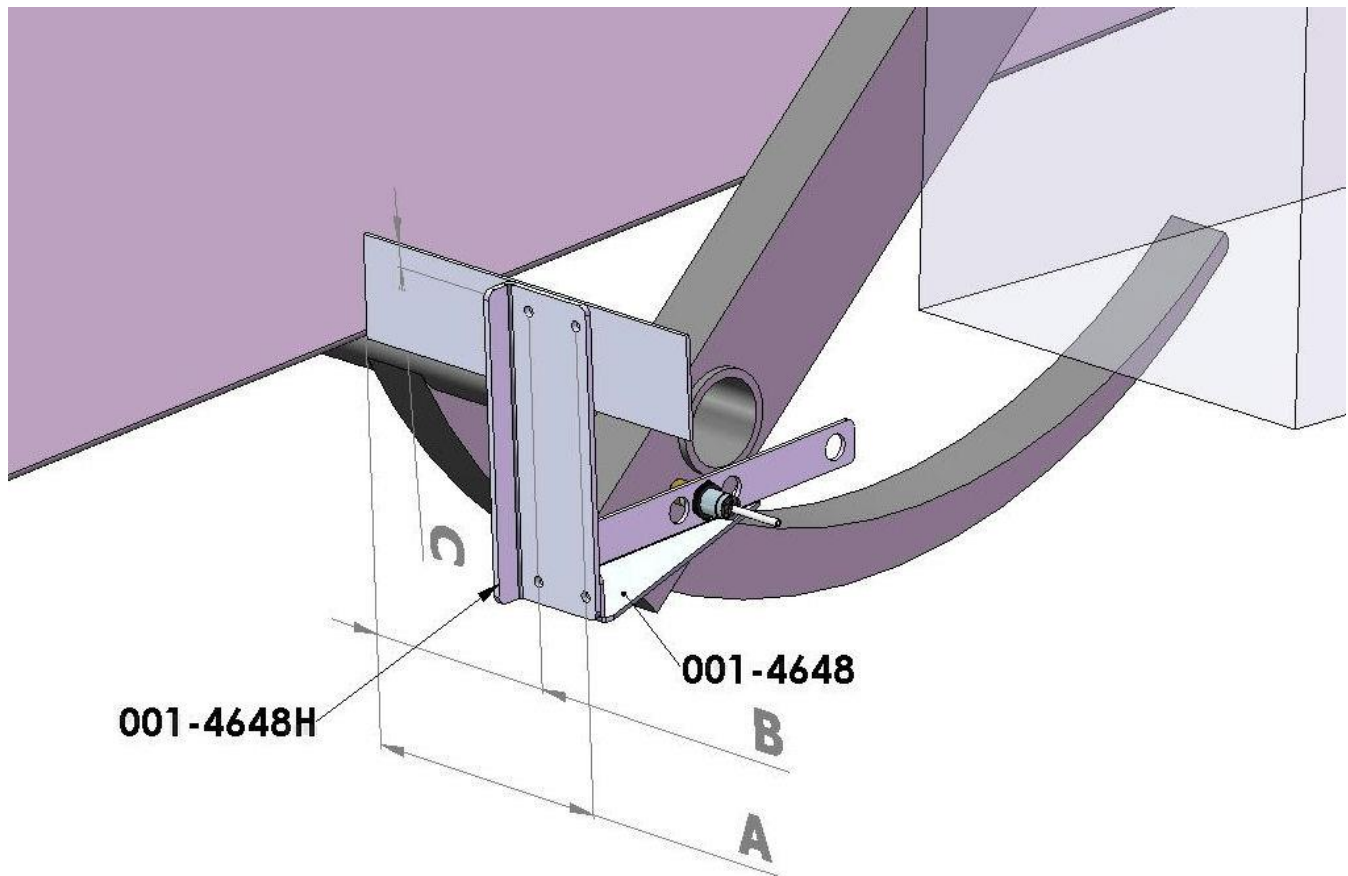

Sensor hole location	A	B	C
7" (18cm)	7-7/8" (20cm)	9-5/8" (25cm)	5/8" (16mm)

Attach the Hesston end of bale mount (001-4648H) as shown. Attach the end of bale sensor bracket (001-4648) to the Hesston end of bale mount (001-4648H) using two 1/4" x 1" bolts, locks & flat washers, and hex nuts. Align the brackets and mark the two 3/8" (10mm) holes to be drilled. Attach the brackets to the baler using two 5/16" x 1 self-tapping screws, and flange nuts.

Mount the sensor in the 7" (18cm) hole location, keep the sensor 1/4" (7mm) from the needle and tighten both nuts. Cut off excess metal past the sensor. Run the sensor cable up to the main harness (006-765B) and attach to port labeled EOB.

Hesston 4760 and 4790

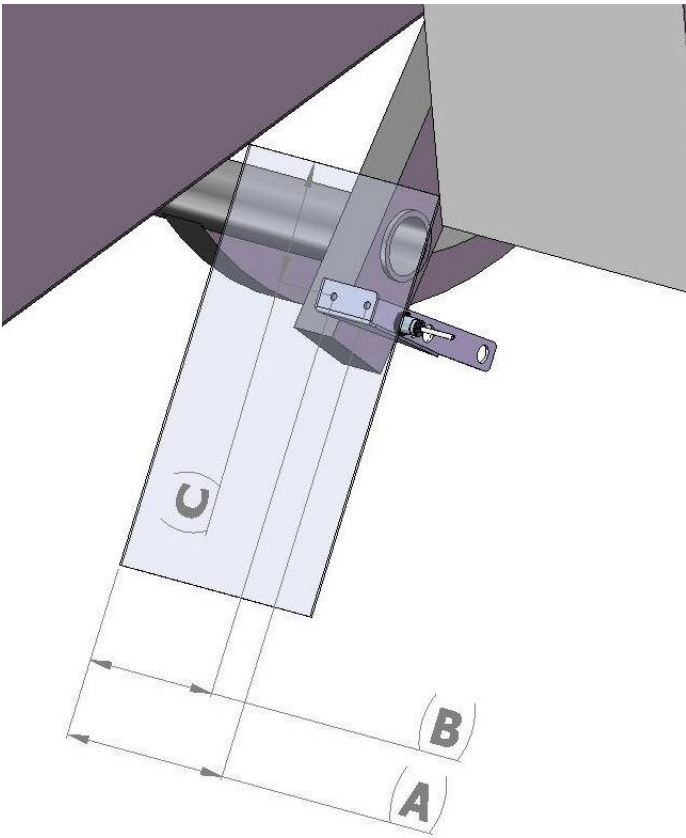

Hesston 4760

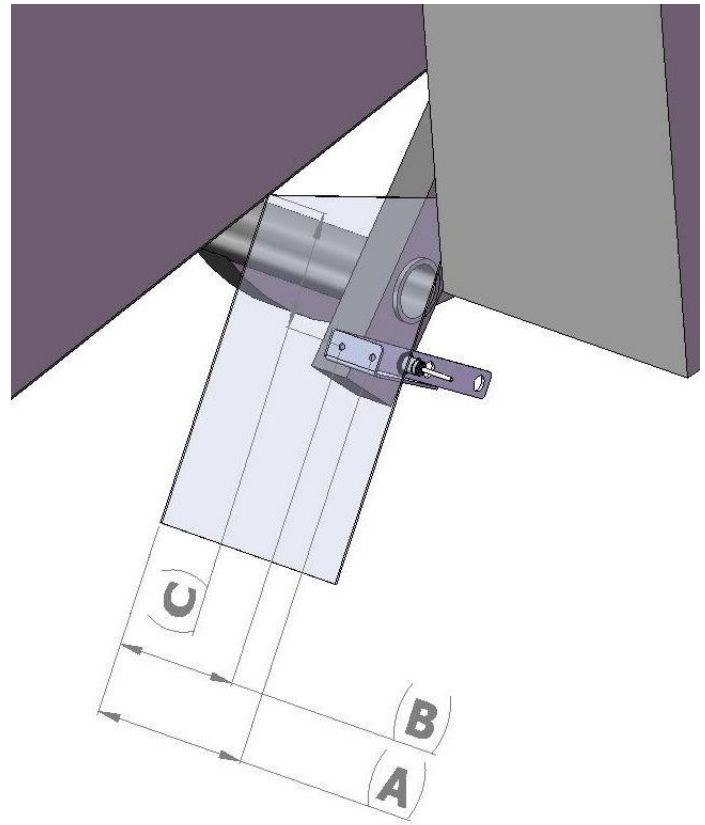

Hesston 4790

Baler	Sensor hole location	A	B	C
4760	6"	6-5/8"	4-7/8"	4"
4790	6"	4-5/8"	2-7/8"	3"

Mount the end of bale sensor bracket (001-4648) as shown. Mark and drill two 3/8" holes and attach the bracket using two 5/16" x 1" self-tapping screws, and 5/16" flange nuts. Mount the sensor in the 6" (15cm) hole location, keep the sensor 1/4" (7mm) from the needle and tighten both nuts. Cut off excess metal past the sensor. Run the sensor cable up to the main harness (006-765B) and attach to port labeled EOB.

Claas 2100

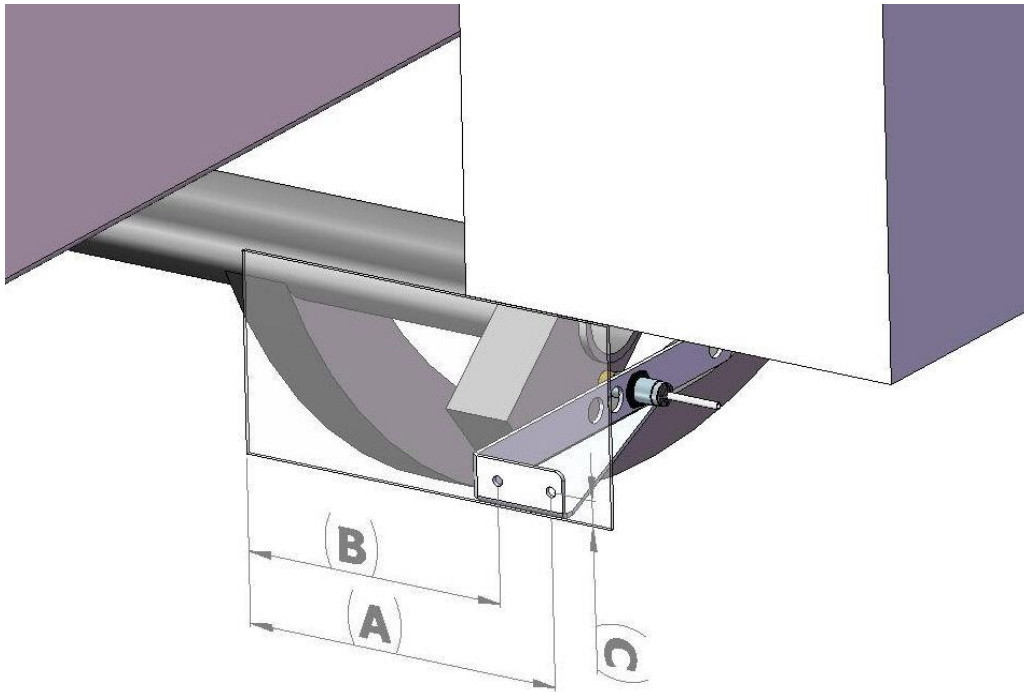

Sensor hole location	A	B	C
8" (20cm)	5-3/4" (13cm)	4" (10cm)	5/8" (16mm)

Mount the end of bale sensor bracket (001-4648) as shown. Mark and drill two 3/8" (10mm) holes and attach the bracket using two 5/16" x 1" self-tapping screws, and 5/16" flange nuts. Mount the sensor in the 8" (20cm) hole location, keep the sensor 1/4" (7mm) from the needle and tighten both nuts. Cut off excess metal past the sensor. Run the sensor cable up to the main harness (006-765B) and attach to port labeled EOB.

Claas 3200-3400, 5300

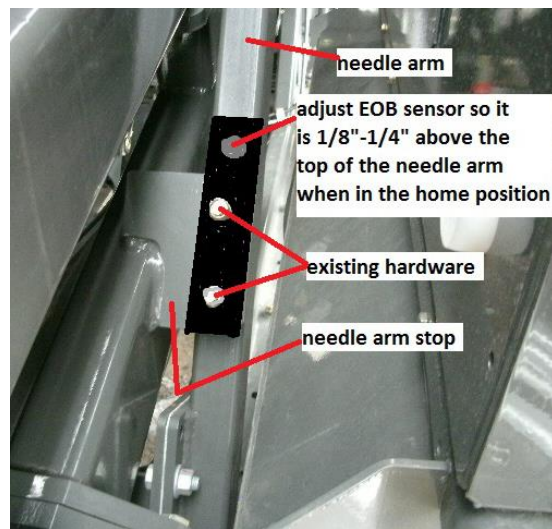
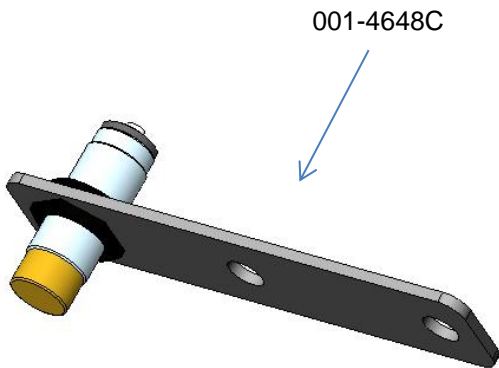

The end of bale (EOB) sensor mounts in the EOB bracket (001-4648C) as shown in the picture. The EOB bracket is mounted to the top side of the needle arm stop using the existing hardware that secures the bumper to the stop.

John Deere 100

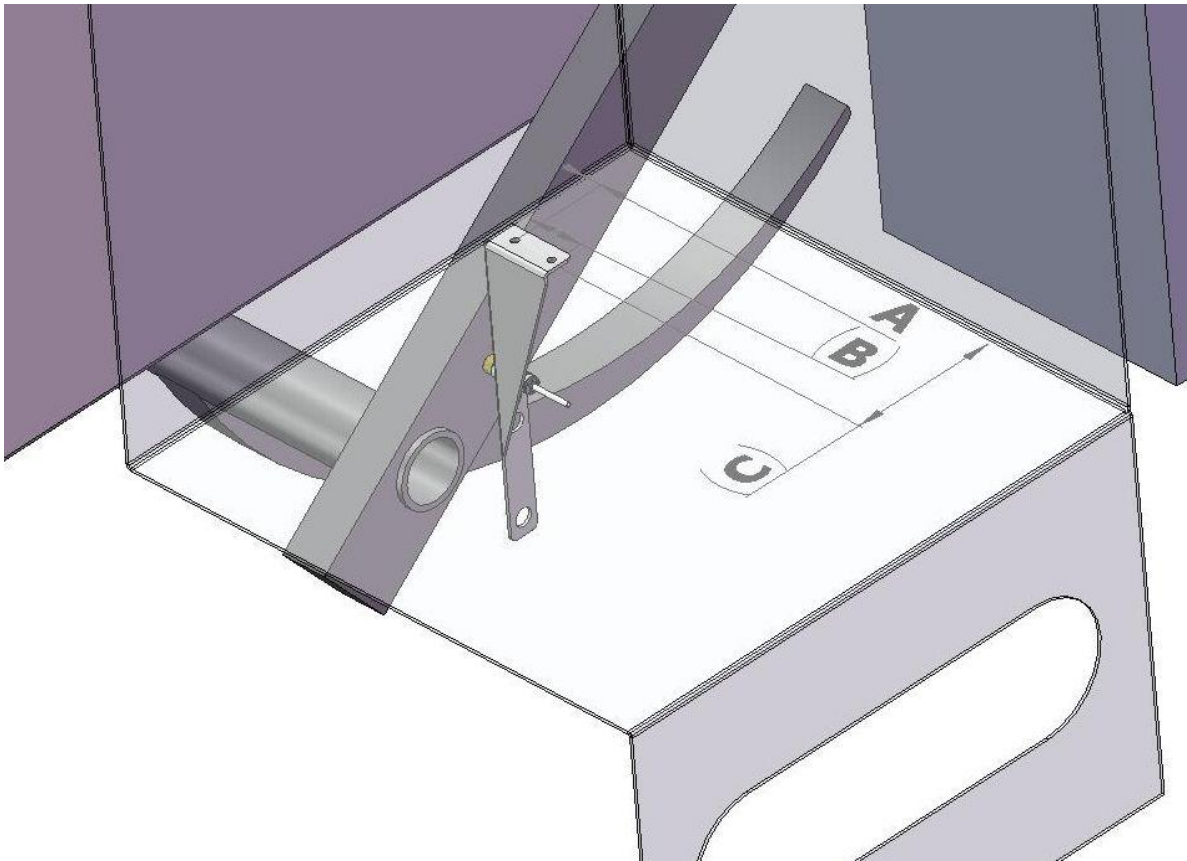

Sensor hole location	A	B	C
6" (15cm)	2-5/8" (70mm)	7/8" (22mm)	7" (18cm)

Mount the end of bale sensor bracket (001-4648) as shown. Mark and drill two 3/8" (10mm) holes and attach the bracket using two 5/16" x 1" self-tapping screws, and 5/16" flange nuts. Mount the sensor in the 6" (15cm) hole location, keep the sensor 1/4" (7mm) from the needle and tighten both nuts. Cut off excess metal past the sensor. Run the sensor cable up to the main harness (006-765B) and attach to port labeled EOB.

Krone 890 – 1290

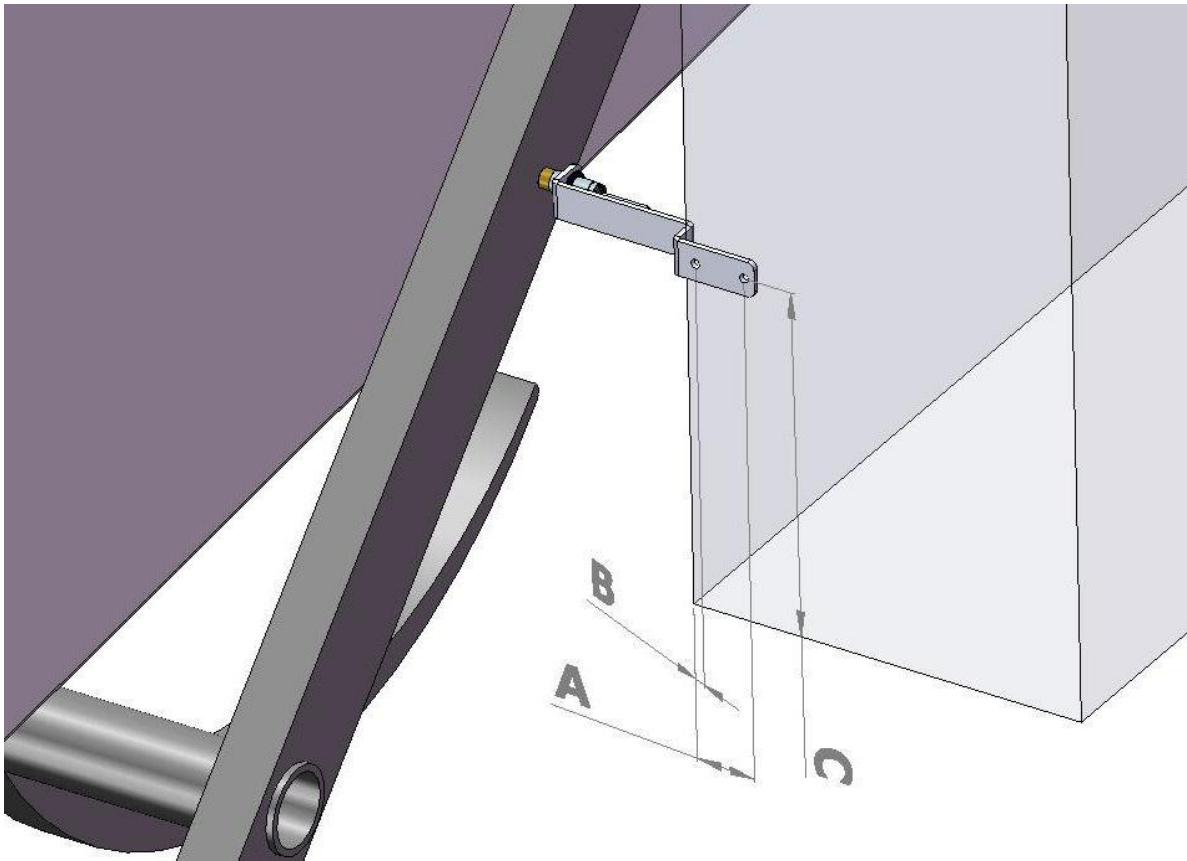

Sensor hole location	A	B	C
N/A	2-1/4" (65mm)	1/2" (13mm)	8" (20cm)

Mount the Krone end of bale sensor bracket (001-4648K) as shown. The Krone mounting bracket can be found in the installation kit box. Mark and drill two 3/8" (10mm) holes and attach the bracket using two 5/16" x 1" self-tapping screws, and 5/16" flange nuts. Mount the sensor at the end of the bracket, keep the sensor 1/4" (7mm) from the needle and tighten both nuts. Run the sensor cable up to the main harness (006-765B) and attach to port labeled EOB.

Krone 12130

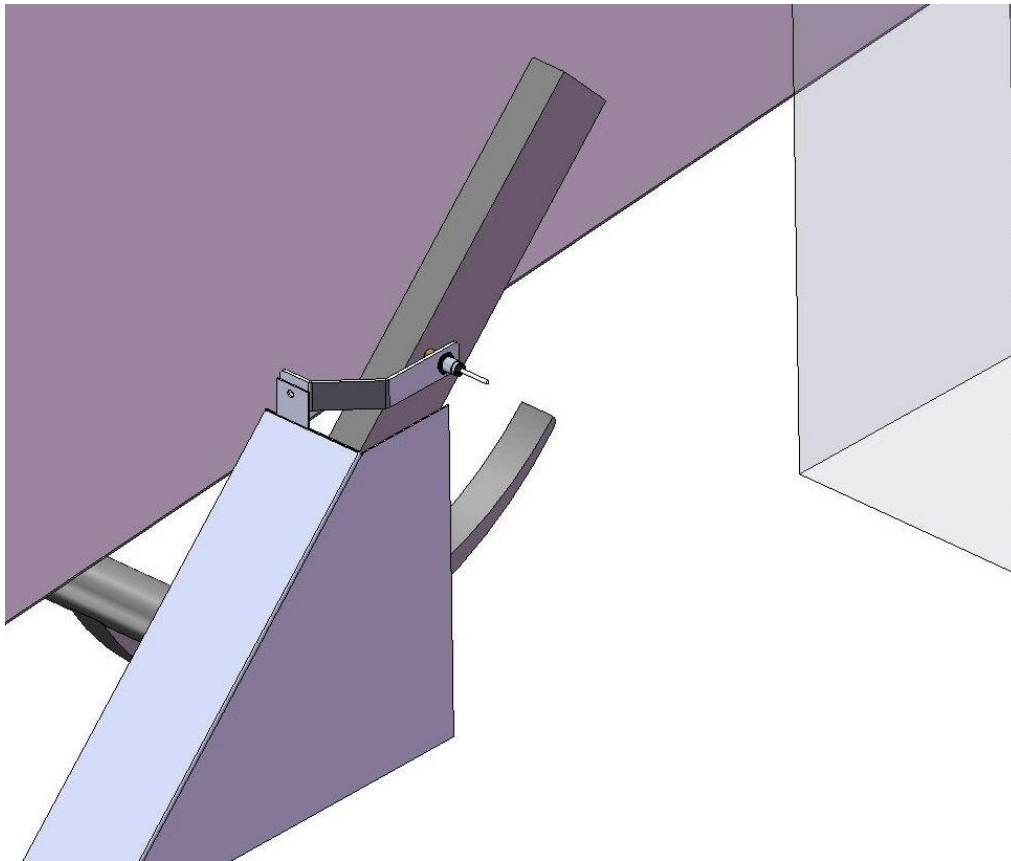

Mount the Krone end of bale sensor bracket (001-4648K2) as shown. The Krone mounting bracket can be found in the installation kit box. Directly behind the twine box on the right side of the baler remove the bolt and nut that secures the fiberglass baler shield to the baler. Mount the sensor bracket using the 3/8 x 1 bolt, lock and nut. Mount the sensor at the end of the bracket, keep the sensor 1/4" (7mm) from the needle and tighten both nuts. Run the sensor cable up to the main harness (006-765B) and attach to port labeled EOB.

Kuhn, Vicon and Taarup Balers

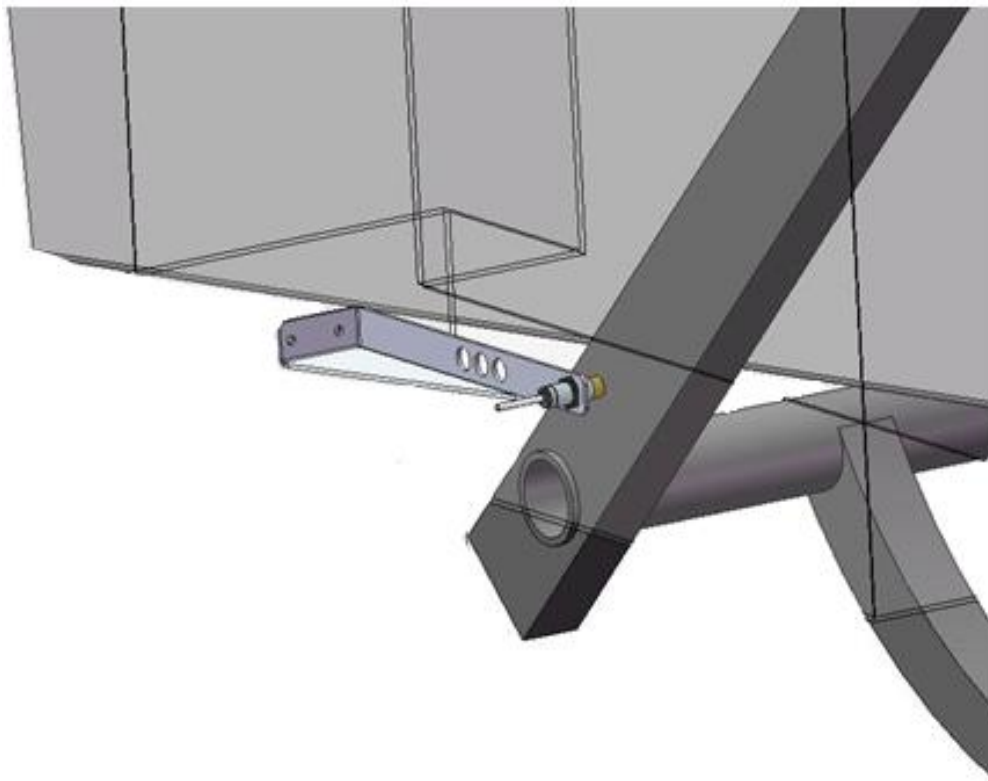

Mount the end of bale sensor bracket (001-4648) as shown. Mark and drill two 3/8" holes and attach the bracket using two 5/16" x 1" self-tapping screws, and 5/16" flange nuts. Mount the sensor in a hole location centered over the needle arm, keep the sensor 1/4" (7mm) from the needle and tighten both nuts. Run the sensor cable up to the main harness (006-765B) and attach to port labeled EOB.

Tractor Setup

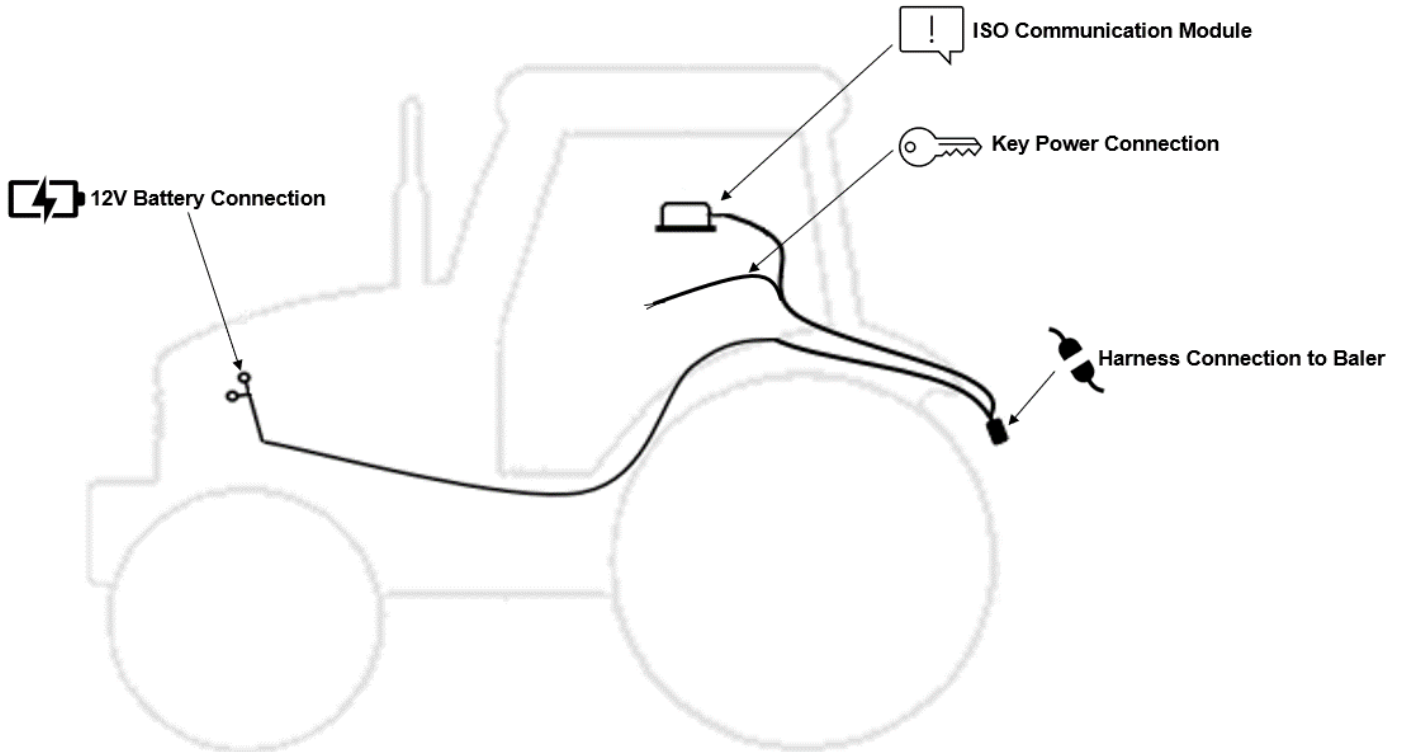

The general tractor setup of the 700 Series applicator can be seen above. The main harness of interest is the tractor power/communication harness (006-7651C). This harness will connect at the tractor battery, to the ISO Communication Module (ICM) mounted in the cab, a keyed power connection point, and connect at the hitch area to the baler power/communication harness (006-765B). View below to see highlighted installation instruction:



12V Battery Connection

The 12V battery connection must be at the tractor battery. Connection to alternative locations such as an accessory port can cause problems with applicator system.

MUST BE CONNECTED DIRECT TO TRACTOR BATTERY TERMINALS



ISO Communication Module

The ISO communication module is to be mounted inside the cab. Other mounting locations can lead to issues with weathering and operation. Once installed and the system is powered, a green light will turn on with the ICM module.



Key Power Connection

Ensure a solid keyed connection is found inside the cab and wired into. Poor keyed power connection can result in applicator system issues.



Harness Connection to Baler

The tractor harness connects at the hitch to baler power/communication harness (006-765B). This will allow the system components to communicate with one another. Ensure connections are debris and corrosion free.

Display Options

Optional Harvest Tec Display



The 700 series Harvest Tec Display will allow you to set your real time baling parameters to ensure the most precise application to every bale. This is done by utilizing the improved touch technology to select objects, enter data, and swipe through operational screens.

The Harvest Tec Display offers easy integration by connecting to the additional CAN plug on the 006-765IC harness. Once, connected the Harvest Tec display will power up with applicator system.

Note: The Harvest Tec Display must be used as a standalone display, the baler cannot run both integrated and on the Harvest Tec Display. Must be one or the other. Removal of the 006-765VA or integration harness is required when equipped.

Optional Tablet Display



The iOS or Android Tablet displays offer the ability to communicate with the 700 series applicator system via hard-wired connection to the ISO Communication Module (ICM). Through the free Precision Baling App, the operator can set real time baling parameters to ensure the most precise application to every bale.

This provides a multi-use option while utilizing the improved app to select objects, enter data, and easily switch through operational screens. The Tablet Display offers easy integration by connecting a charging cable to the USB port on the ICM module. Once connected the Harvest Tec applicator will display upon opening the app and powering up the applicator system. Tablets can be used in addition to integrated baler VT display.

***Made for iPad® (3rd generation minimum) or Android Tablet (Does not work with Amazon Fire).
Required to be running the most current operating system or one version previous.**

*iPad is a trademark of Apple Inc., registered in the U.S. and other countries.

Wiring Diagram – 700 Series

1. Connect the power harness (006-7651C) to the tractor battery (12 volt) using the red wire with fuse to the positive side and the black wire to the negative.



A. The power harness must be connected to the battery!

CONTACT HARVEST TEC BEFORE MODIFICATIONS.

The unit will draw more amps than convenience outlets can handle. Any modifications of the power harness will void systems warranty

B. This unit will not function on positive ground tractors.

C. If the unit loses power while operating it will not keep track of accumulated pounds of product used.

2. The power harness on the tractor (006-7651C) will run from the tractor battery to the hitch. The power harness on the baler (006-765B) will connect to the tractor power harness (006-7651C) at the hitch.
3. Connect the keyed power wire (006-765CPH) to a keyed power source on the tractor.

The keyed power wire must connect to a keyed source or the unit will not power up correctly.

4. Attached the ISO Communication Module (006-6673) to the tractor power harness (006-7651C).
5. Attach the End of Bale (EOB) connection on baler harness (006-765B) to the EOB Sensor (006-7401).
6. Attach the Solenoids (SOL 1 & 2) connections on the baler harness (006-765B) and to the solenoids (002-2203F).
7. Attach the Flowmeter (006-4724A) to the Pump Module connection on pump plate assembly.
8. Attach the rubber molded connector on pump plate to the Pump (007-4120DE).
9. Attach star wheel (030-442U/UE) connection to the pump module

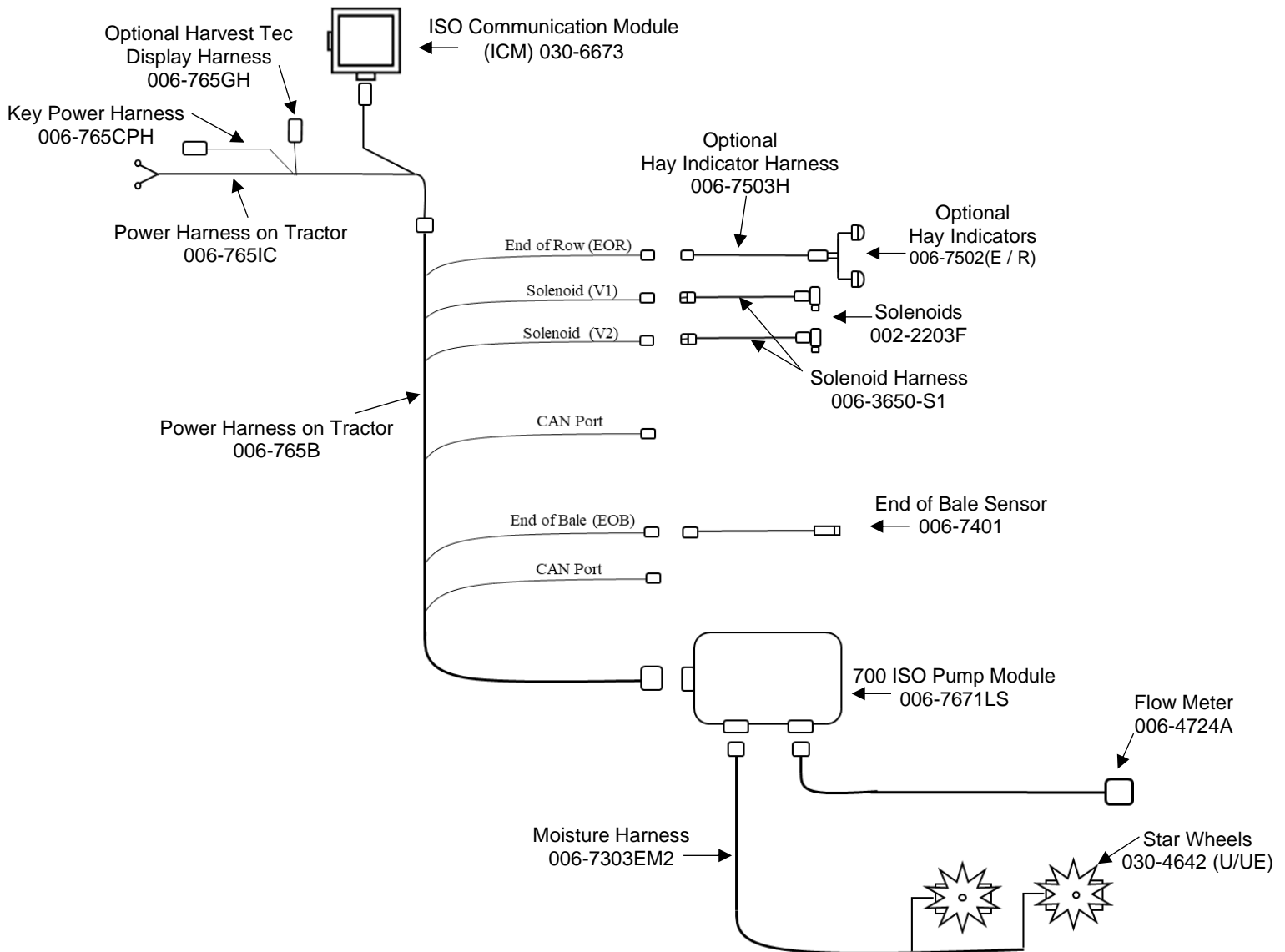

Pin Outs

Integrated Control Module (ICM) on harness 006-765IC

(Deutsch Plug Number: DTM06-12SA)

Pin 1	Red	+12V from ECU
Pin 2	Purple	Signal Wire
Pin 3	Red/White	+12V CAN X
Pin 4	Black/White	Ground CAN X
Pin 5	Orange	CAN X Hi
Pin 6	Blue	CAN X Lo
Pin 7	Green	ISO CAN Lo
Pin 8	Yellow	ISO CAN Hi
Pin 9	White	GPS Expansion 1
Pin 10	Gray	GPS Expansion 2
Pin 11	Brown	GPS Expansion 3
Pin 12	Black	Ground from ECU

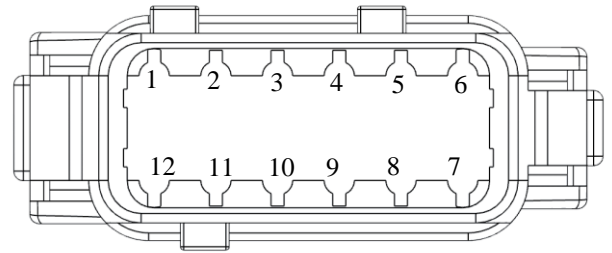

ISOBUS Plug on harness 006-765IC

(Deutsch Plug Number: DT04-4P)

Pin 1	Red	+12V from ECU
Pin 2	Yellow	ISO CAN Hi
Pin 3	Green	ISO CAN Lo
Pin 4	Black	Ground from ECU

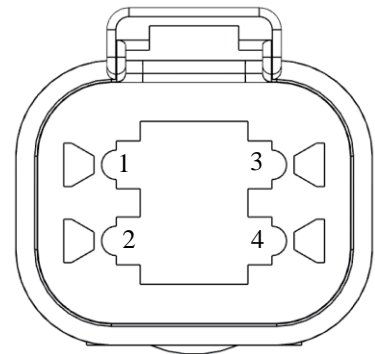

Power / Communication Harness 006-765IC at Baler Hitch

(Deutsch Plug Number: HDP24-24-18PN)

Pin 1	Not Used	----
Pin 2	Yellow	ISO CAN Hi
Pin 3	Green	ISO CAN Lo
Pin 4	Red	+12V Power to ECU
Pin 5	Black	Ground to ECU
Pin 6	Red	+12V From Battery
Pin 7	Not Used	----
Pin 8	Black	Ground From Battery
Pin 9	Not Used	----
Pin 10	Purple	Signal Wire
Pin 11	Red/White	+12V CAN X
Pin 12	Black/White	Ground CAN X
Pin 13	Orange	CAN X Hi
Pin 14	Blue	CAN X Lo
Pin 15	White	GPS Expansion 1
Pin 16	Gray	GPS Expansion 2
Pin 17	Brown	GPS Expansion 3
Pin 18	Not Used	----

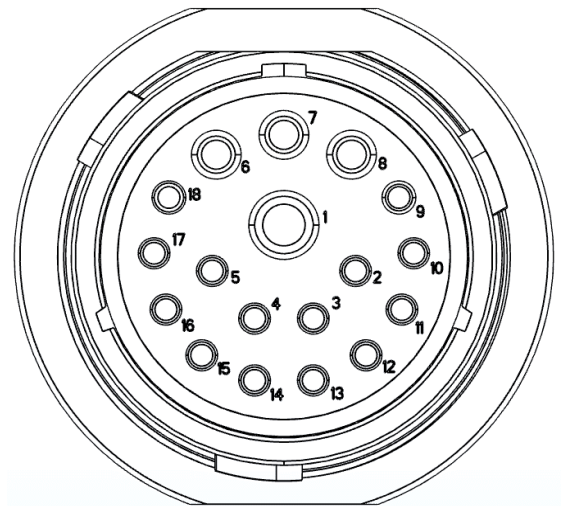

Pin Outs (continued)

Power / Communication Harness 006-765B at Baler Hitch IPM

(Deutsch Plug Number: HDP26-24-18SN)

Pin 1	Not Used	----
Pin 2	Yellow	ISO CAN Hi
Pin 3	Green	ISO CAN Lo
Pin 4	Red	+12V Power to ECU
Pin 5	Black	Ground to ECU
Pin 6	Red	+12V From Battery
Pin 7	Not Used	----
Pin 8	Black	Ground From Battery
Pin 9	Not Used	----
Pin 10	Orange/White	+12V Power to EOR
Pin 11	Not Used	----
Pin 12	Not Used	----
Pin 13	Not Used	----
Pin 14	Not Used	----
Pin 15	Not Used	----
Pin 16	Not Used	----
Pin 17	Not Used	----
Pin 18	Not Used	----

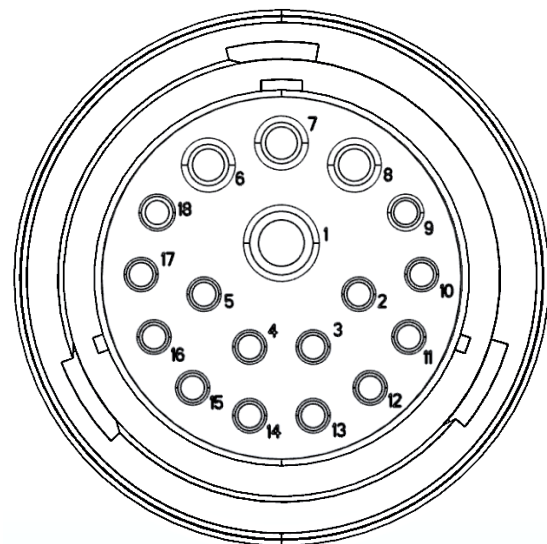

Power / Communication Harness 006-765B at IPM Module

(Deutsch Plug Number: HDP24-24-18SN)

Pin 1	Not Used	----
Pin 2	Yellow	ISO CAN Hi
Pin 3	Green	ISO CAN Lo
Pin 4	Red	+12V Power to ECU
Pin 5	Black	Ground to ECU
Pin 6	Red	+12V From Battery
Pin 7	Not Used	----
Pin 8	Black	Ground From Battery
Pin 9	Not Used	----
Pin 10	Orange/White	+12V Power to EOR
Pin 11	Orange/Black	Ground to EOR
Pin 12	Purple/Green	EOR Signal
Pin 13	Blue/White	EOB Signal
Pin 14	Gray/Red	+12V Power to Solenoid 1
Pin 15	White/Black	Ground to Solenoid 1
Pin 16	Orange/Red	+12V Power to Solenoid 2
Pin 17	White/Black	Ground to Solenoid 2
Pin 18	Not Used	----

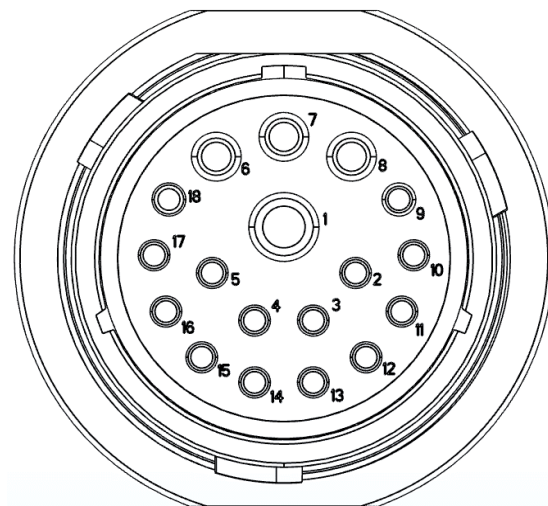

Solenoid 1 Plug on Baler Harness 006-765B

(Deutsch Plug Number: APTIV 12052641)

Pin B	Gray/Red	+12V to Solenoid 1
Pin A	White/Black	Ground to Solenoid 1

Solenoid 2 Plug on Baler Harness 006-765B

(Deutsch Plug Number: APTIV 12052641)

Pin B	Orange/Red	+12V to Solenoid 2
Pin A	White/Black	Ground to Solenoid 2

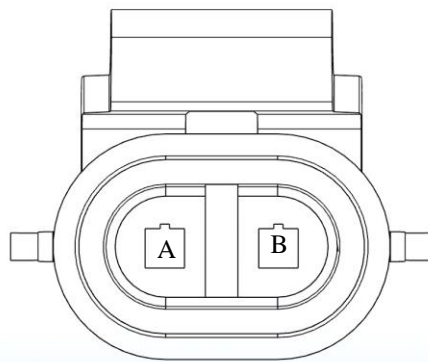

Pin Outs (continued)

CAN / IDM on Baler Harness 006-765B

(Deutsch Plug Number: DT06-4S)

Pin 1	Red	+12V to Solenoid 2
Pin 2	Yellow	ISO CAN Hi
Pin 3	Green	ISO CAN Lo
Pin 4	Black	Ground to Solenoid 2

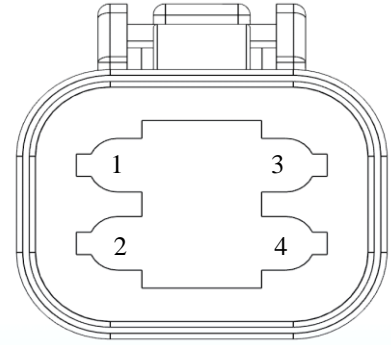

End of Bale Sensor Plug on Baler Harness 006-765B

(Deutsch Plug Number: DT06-3S)

Pin 1	Orange/White	+12V to End of Bale Sensors
Pin 2	Orange/Black	Ground to End of Bale Sensors
Pin 3	Blue/White	Signal

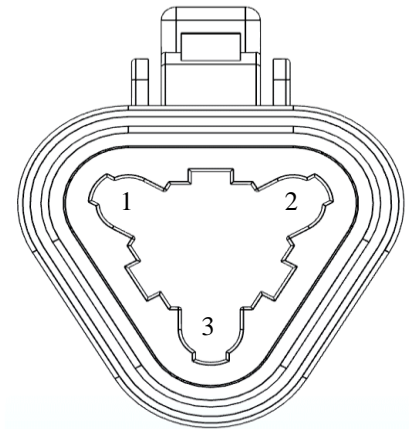

End of Row Sensors Plug on Baler Harness 006-765B

(Deutsch Plug Number: DT06-3S)

Pin 1	Orange/White	+12V to End of Bale Sensors
Pin 2	Orange/Black	Ground to End of Bale Sensors
Pin 3	Blue/White	Signal

Integration Harness Plug on Baler Harness 006-765B

(Plug: APTIV 12052848)

Pin A	Not Used	----
Pin B	Red	+12V Power
Pin C	Not Used	----
Pin D	Gray	Ground
Pin E	Orange	CAN Hi
Pin F	Blue	CAN Lo

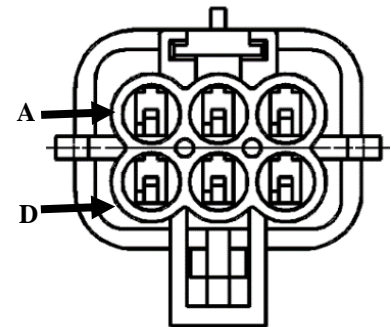

Pump Connection on 700 Controller Harness

(16 AWG Two-Wire Plug)

Pin 1	Red	Power to Pump
Pin 2	Black	Ground to Pump

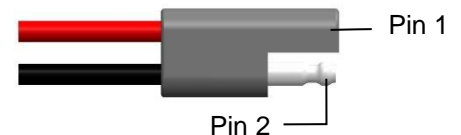

Parts Breakdown Tank, Saddle & Legs 100 Gallon

Vermeer, Claas, and Krone Balers with 100 Gallon Tank



Vermeer, Claas and Krone Balers Saddle Legs

Part#: 001-6706V

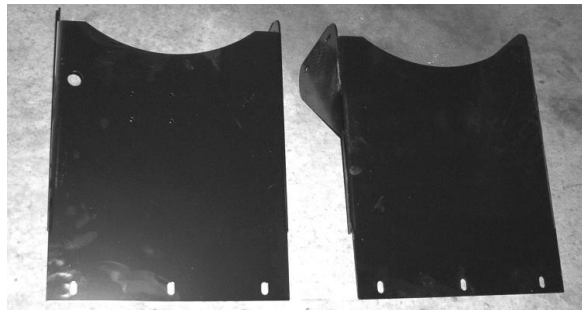

*If the applicator is being mounted on a **Krone 870 HDP** baler, two leg adapter brackets will be needed for proper tank leg installation (below). Part number 001-6707KV.

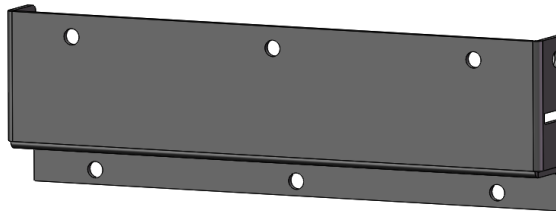

Claas 3300 Saddle Legs

Part #: 001-6706C



Tank, Saddle and Legs 110 Gallon



- Tank Lid**
Part#: 005-9022H
(8" Dia)
- Tank-110 gallon**
Part#: 005-9208
- Hand Rail**
Part#: 001-6707HR
- Tank Straps**
Part#: 001-4402B
- Tank Saddle**
Part#: 001-6707A
- Tank Fitting**
Part#: 005-9100

Not Pictured: Elbow
Part#:003-EL3412

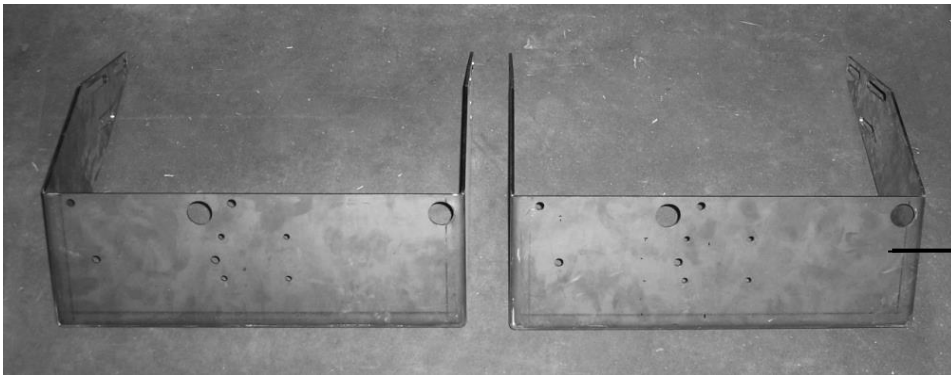

Agco, Hesston, Massey & Challenger Saddle Legs

Part#: 001-6707C

**New Holland BB940A, BB960A,
Case IH LBX 332, LBX 432 Series
Saddle Legs**

Not Pictured:
Vicon Leg Spacers:
Part#: 001-6707BS (x2)

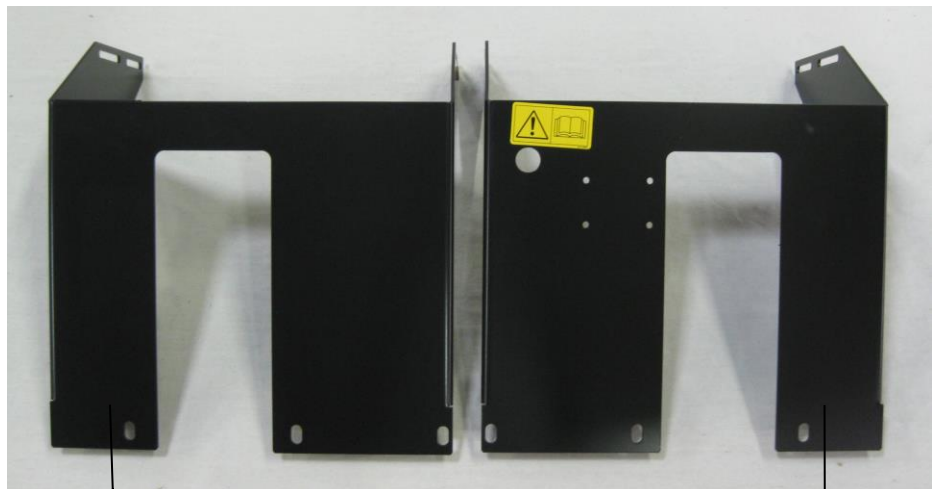

Left Leg Part#:001-6707BL
(2010 and older 4 ft wide)

Right Leg Part #:001-6707BR
(2010 and older 4 ft wide)

Tank, Saddle and Legs 110 Gallon (continued)

New Holland BB940A, BB960A,
Case IH LBX 332, LBX 432 Series
Saddle Legs



Left Leg Part#: 001-6707DL
(2011 and newer 4 ft wide)

Right Leg Part #: 001-6707DR
(2011 and newer 4 ft wide)

Krone Balers

Part#: 001-6707KA



*If the applicator is being mounted on a **Krone 12130 & 2010** baler, two leg adapter brackets will be needed for proper tank leg installation (below). Part number 001-6707KB.

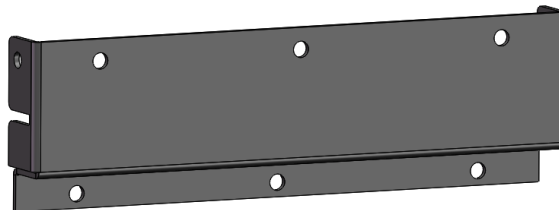

Pump Assembly

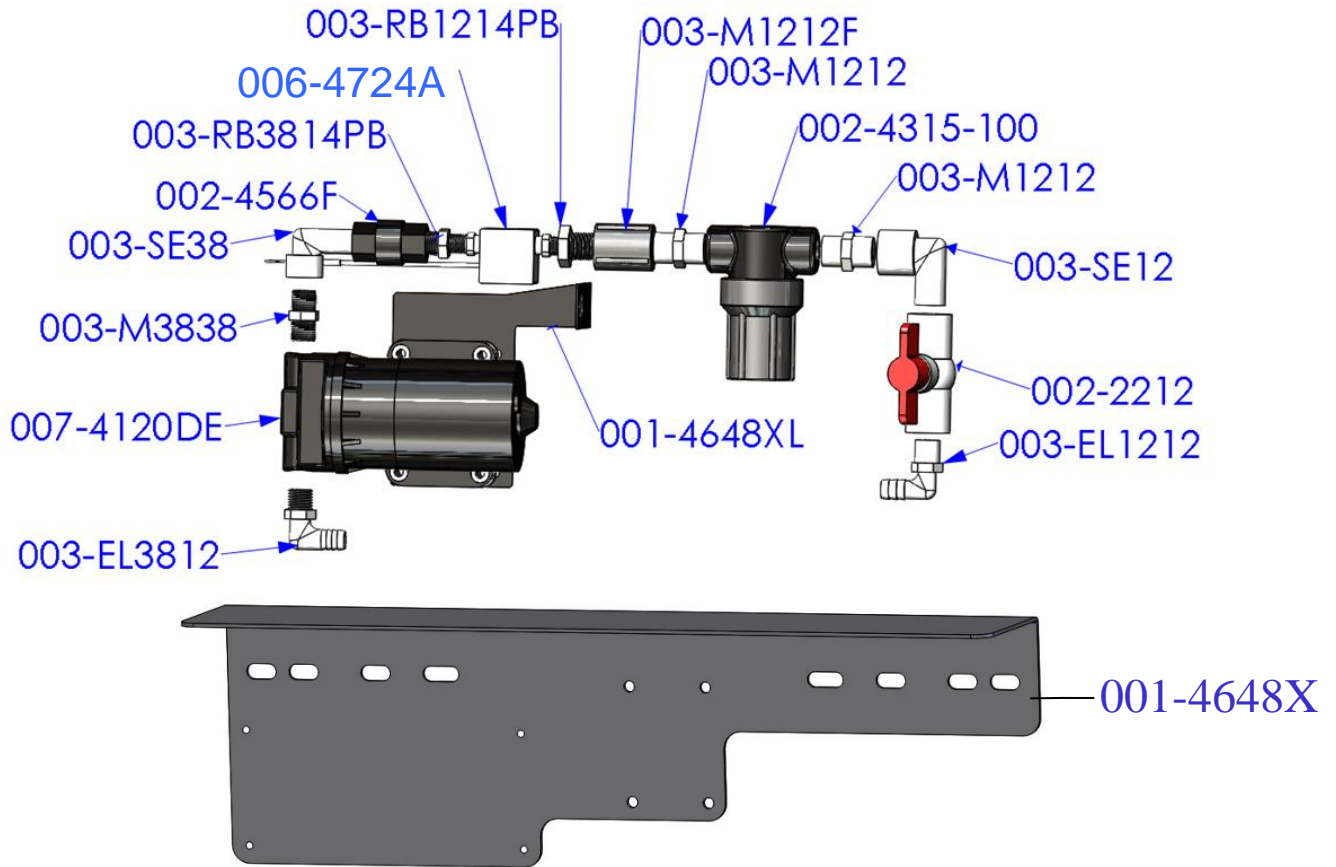

<u>Part#</u>	<u>Description</u>	<u>Qty</u>	<u>Part#</u>	<u>Description</u>	<u>Qty</u>
003-EL3812	3/8" MPT X 1/2" HB Elbow	1	003-M1212	1/2" Union	2
007-4120DE	700 Series Pump	1	002-4315-100	1/2" Line Strainer-100 Mesh	1
003-M3838	3/8" x 3/8" Union	1	003-SE12	1/2" Street Elbow	1
003-SE38	3/8" Street Elbow	1	002-2212	1/2" Ball Valve	1
002-4566F	3/8" Check Valve	1	003-EL1212	1/2" MPT x 1/2" HB	1
003-RB3814PB	RB 3/8" x 1/4" Reducer	1	001-4648XL	700 Pump Support	1
006-4724A	Flow Meter	1	001-4648X	Pump Plate Mount	1
003-RB1214PB	RB 1/2" x 1/4" Reducer	1	003-A1212	Not Pictured	1
003-M1212F	1/2" Coupler	1	003-A3812	Not Pictured	1

Completed Assembly

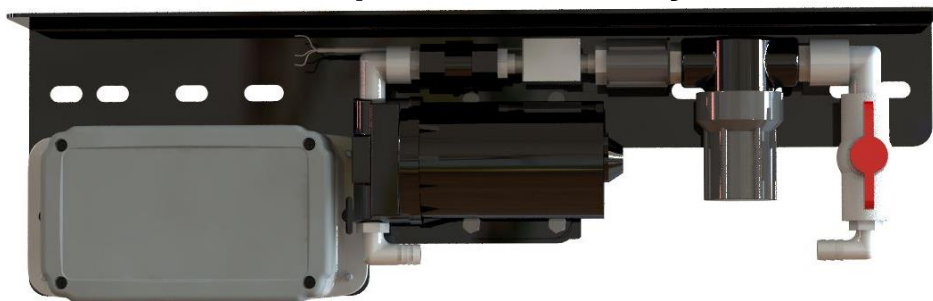

Note: Due to alternative baler designs, elbow 003-EL3812 can be replaced by straight fitting 003-A3812. As well as elbow 003-EL1212 can be replaced by straight fitting 003-A1212. Both straight fittings are included.

Star Wheel Sensors

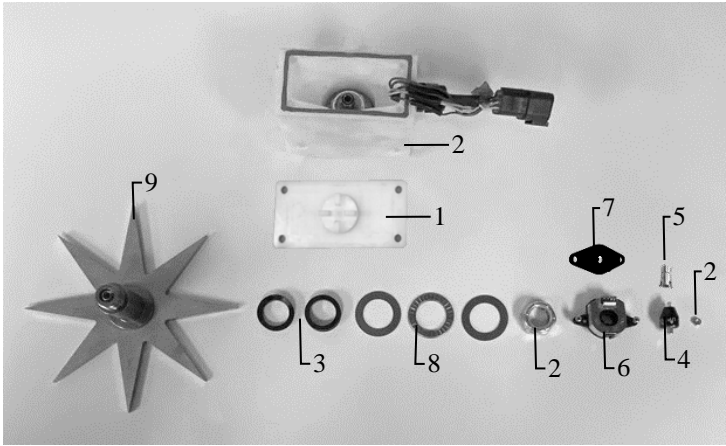

<u>Ref</u>	<u>Description</u>	<u>Part#</u>	<u>Qty</u>
1	Block Cover	006-4642UC	1
2	Star Wheel Block	006-4642UB	1
3	Star Wheel Gasket	006-4642UG	1
4	Electric Swivel	006-4642A	1
5	Swivel Insert	006-4642B	1
6	Encoder	006-4512E	1
7	Encoder Mount	006-4512P	1
8	Washers	006-4642K	1
9	Star Wheel	006-4642US	1
10	Encoder Harness (6 pin)	006-7307EM	1
NP	Moisture Harness (2-pin)	006-7307M	1
1-10	Star wheel assembly (w/ Encoder)	030-4642UE	1
1-5 8,9,	Star wheel assembly (w/o Encoder)	030-4642U	1

Moisture Harness



<u>Ref</u>	<u>Description</u>	<u>Part #</u>	<u>Qty</u>
11	Moisture Harness	006-7307EM2	1

Control Box and Wiring Harnesses



<u>Ref</u>	<u>Description</u>	<u>Part#</u>	<u>Qty</u>	<u>Ref</u>	<u>Description</u>	<u>Part#</u>	<u>Qty</u>
1	Power Lead Baler 20'	006-765B	1	NP	Baler Integration Harness	006-765VA	1
2	Power lead tractor	006-765IC	1	NP	120 Ohm Resistor	006-700R	1
3	Key Switch Wire	006-765CPH	1	NP	Dust Plug Kit	006-765DP	1
4	ISO Pump Module	006-7671LS	1				
5	ISO Communication Module	006-6673	1				

End of Bale Sensor Kit

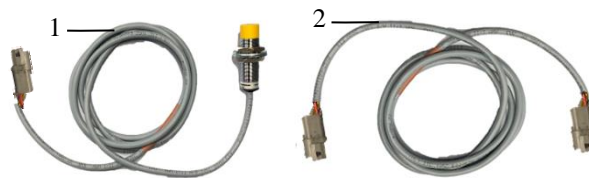

<u>Ref</u>	<u>Description</u>	<u>Part #</u>	<u>Qty</u>
1	End of Bale Sensor	006-7401	1
2	End of Bale Ext.	006-7401EXT	1

Complete Assembly

EOB-LS-STD

700 Solenoid Package

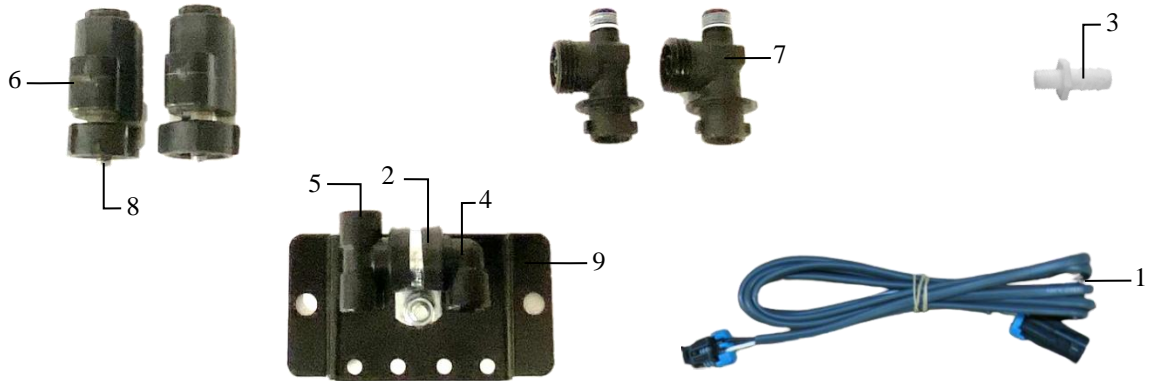

Solenoid Package

<u>Ref</u>	<u>Description</u>	<u>Part #</u>	<u>Qty</u>	<u>Ref</u>	<u>Description</u>	<u>Part #</u>	<u>Qty</u>
1	Solenoid Harness (5')	006-3650-S1	2	6	Solenoid	002-2203F	2
2	Hose Clamp #6	003-9003	1	7	Solenoid Check Valve	004-1207VF	2
3	1/4" x 1/2" Straight Fitting	003-A1412	1	8	1/4" Nipple	003-M14	2
4	1/4" Elbow	003-SE14F	1	9	Solenoid Holder	001-4648DSH	1
5	1/4" Tee Fitting	003-TT14SQ	1	NP	O-Ring Kit	002-2203FG	2
					Complete Assembly	SOL-3SP-LSB	

Hose and Drain/Fill Line

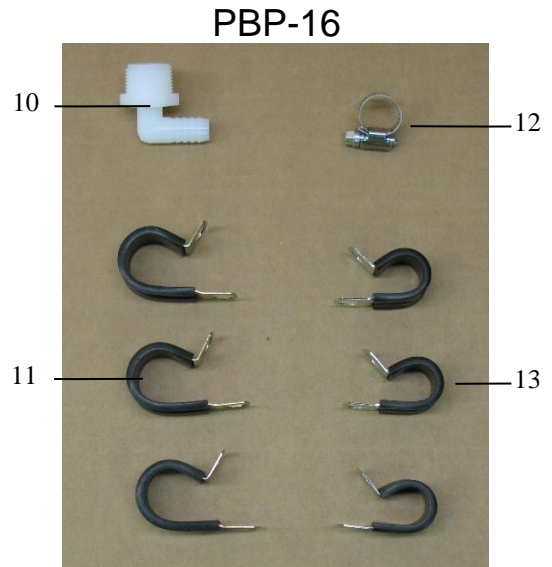
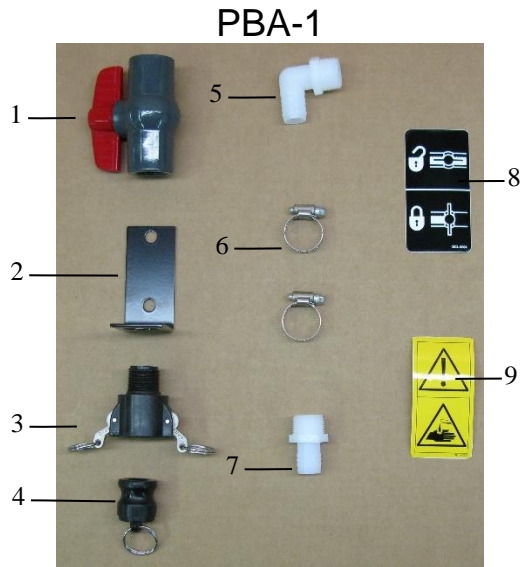

<u>Ref</u>	<u>Description</u>	<u>Part #</u>	<u>Qty</u>
1	3/4" Ball Valve	002-2200	1
2	Valve Holder	001-6702H	1
3	Female Coupler	002-2204A	1
4	Male Shut-Off Plug	002-2205G	1
5	3/4" x 3/4" Elbow	003-EL3434	1
6	#10 Hose Clamp	003-9004	2
7	3/4" x 3/4" Straight Fitting	003-A3434	1

<u>Ref</u>	<u>Description</u>	<u>Part #</u>	<u>Qty</u>
8	Valve Decal	DCL-8004	1
9	Hazard Decal	DCL-8001	1
10	3/4" x 1/2" Elbow	003-EL3412	1
11	3/4" Jiffy Clip	008-9010	3
12	#6 Hose Clamp	003-9003	1
13	Small Jiffy Clip	008-9009	3
10	3/4" x 1/2" Elbow	003-EL3412	1

Complete Drain Fill Kit

030-0493DFK

Hoses

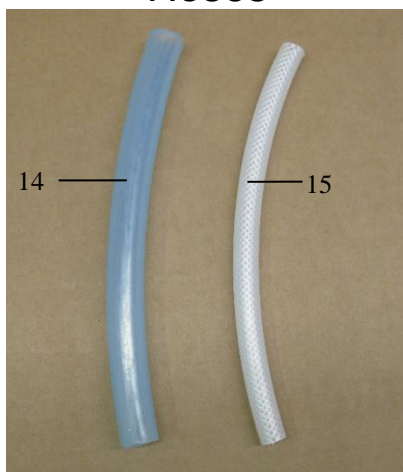

<u>Ref</u>	<u>Description</u>	<u>Part #</u>	<u>Qty</u>
14	1/2" Hose (Tank to Solenoid)	002-9001	15ft
15	1/4" Hose (Solenoid to Tips)	002-9016	6ft

Optional iPad Mini Mounting Kit (030-2014MK)

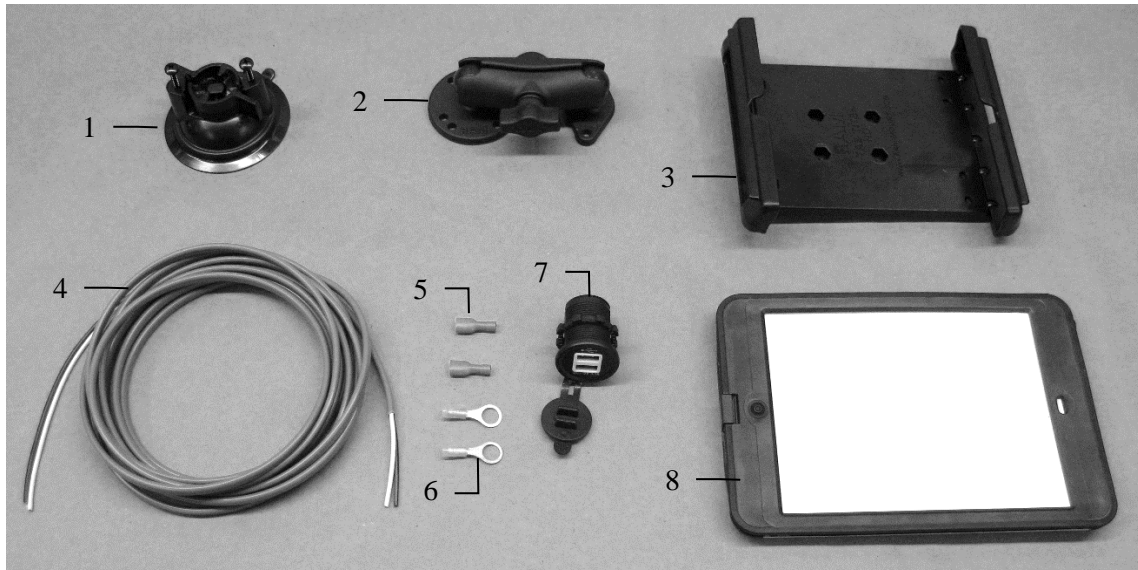

<u>Ref</u>	<u>Description</u>	<u>Part #</u>	<u>Qty</u>
1	Suction cup mount	001-2012SCM	1
2	Ram mount	001-2012H	1
3	iPad Mini® spring load cradle (Mini 4)	001-2012SLC	1
4	16 gauge power wire	006-4723P	1
5	Female spade connector	Hardware	2
6	Eye loop connector	Hardware	2
7	iPad Mini Charger 12V	001-2012P	1
8	iPad Mini 4 case	001-2012C4	1
NP	4 amp fuse	Hardware	1
	Mounting Kit Assembly	030-2014MK (Includes All Parts)	

Installation Instructions

1. Identify 12V power source for wires to connect.
 - a. Eye loops included if wiring directly to the battery is desired.
 - b. Test for key power source if preferred to have power to the USB shut off with the key.
2. Once power source is identified, cut wires to desired length.
3. Crimp the two supplied quick connectors onto each the white and black wire.
4. Remove the round locking plastic nut from USB plug before connecting the wires. Black (+) White (-).
5. The wires will then be hooked to the designated terminals on the bottom of the USB plug
6. Drill a 1 1/8" hole in the preferred mounting location. Be sure to clean any sharp edges after drilling.
7. Feed the wires through the mounting hole.
8. If using the round plastic nut to secure plug in place, slide the nut back over the wiring before connecting the wires to powered source.
9. Connect the wires to the identified power source if easier to do so before tightening the plug into place.
10. Tighten plug using either the round plastic nut or mounting plate and two screws, both options supplied.
11. Once connected, hook a USB charging cord into the plug and connect a mobile device/tablet to ensure the plug is operating as you wish (key power working properly if necessary).

NOTE: This plug is not designed to charge two iPads. System damage could occur if this is attempted. System will charge a mobile phone and iPad simultaneously without problem.

*iPad mini is a trademark of Apple Inc., registered in the U.S. and other countries.

Optional iPad Display Kit (030-4670DK)

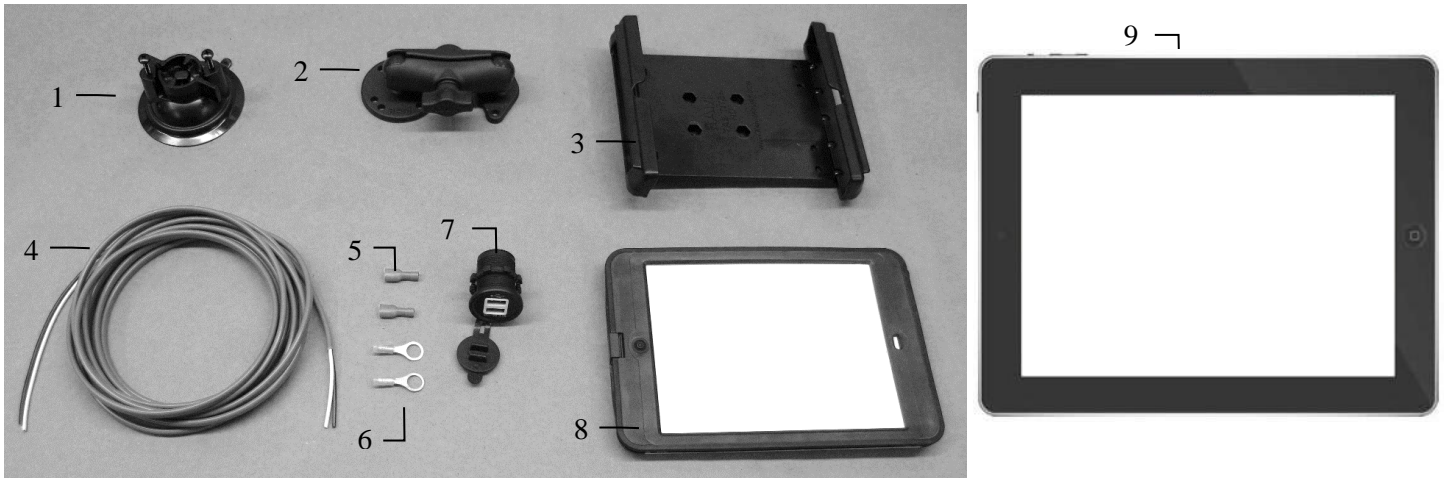

Ref	Description	Part #	Qty	Ref	Description	Part #	Qty
1	Suction cup mount	001-2012SCM	1	7	iPad Mini Charger 12V	001-2012P	1
2	Ram mount	001-2012H	1	8	iPad Mini 4 case	001-2012C4	1
3	Spring load cradle (Mini 4)	001-2012SLC	1	9	iPad Mini 4	006-4670IP	1
4	16 gauge power wire	006-4723P	1	NP	4 Amp fuse	Hardware	1
5	Female spade connector	Hardware	2				
6	Eye loop connector	Hardware	2				
					Mounting Kit Assembly	030-4670DK (Includes All Parts)	

Installation Instructions

1. Identify 12V power source for wires to connect.
 - a. Eye loops included if wiring directly to the battery is desired.
 - b. Test for key power source if preferred to have power to the USB shut off with the key.
2. Once power source is identified, cut wires to desired length.
3. Crimp the two supplied quick connectors onto the white and black wire.
4. Remove the round locking plastic nut from USB plug before connecting the wires. Black (+) White (-).
5. The wires will then be hooked to the designated terminals on the bottom of the USB plug
6. Drill a 1 1/8" hole in the preferred mounting location. Be sure to clean any sharp edges after drilling.
7. Feed the wires through the mounting hole.
8. If using the round plastic nut to secure plug in place, slide the nut back over the wiring before connecting the wires to powered source.
9. Connect the wires to the identified power source if easier to do so before tightening the plug into place.
10. Tighten plug using either the round plastic nut or mounting plate and two screws, both options supplied.
11. Once connected, hook a USB charging cord into the plug and connect a mobile device/tablet to ensure the plug is operating as you wish (key power working properly if necessary).

NOTE: This plug is not designed to charge two iPads. System damage could occur if this is attempted. System will charge a mobile phone and iPad simultaneously without problem.

*iPad mini is a trademark of Apple Inc., registered in the U.S. and other countries.

Optional Android Display Kit (030-1670DK)

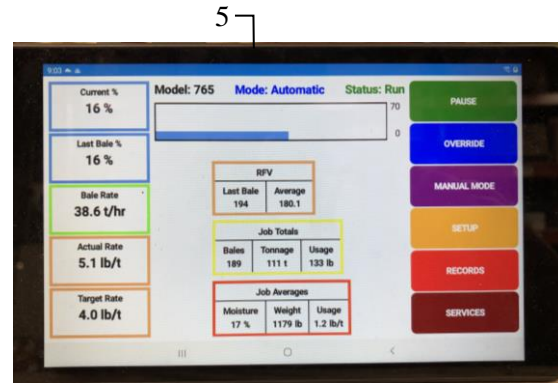
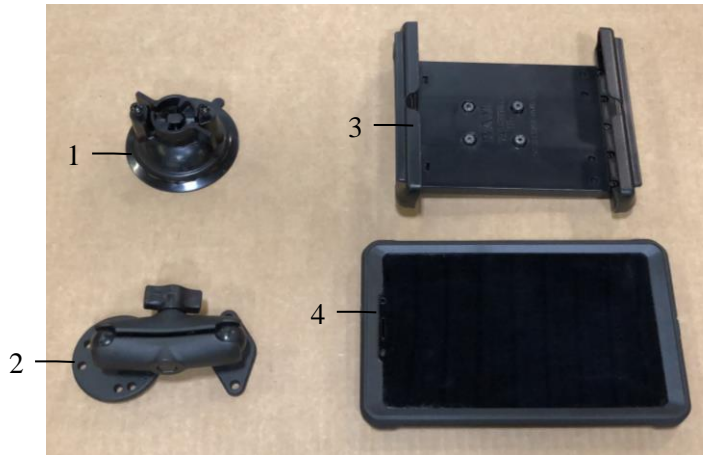

<u>Ref</u>	<u>Description</u>	<u>Part #</u>	<u>Qty</u>
1	Suction Cup Mount	001-2012SCM	1
2	Ram Mount	001-2012H	1
3	Spring Load Cradle	001-2012SLC	1
4	Android Case	001-2012A1	1
5	Android Tablet	006-1670AT	1

Installation Instructions

1. Assemble Cradle (001-2012SLC)
2. Attach round base from ram mount to cradle
3. Attach trapezoid end of ram mount to suction mount
4. Clean glass or metal surface that unit will be attaching to.
5. Add a small amount of water to suction cups rubber surface and attach to surface
6. Turn lock on suction cup mount to secure.
7. Place tablet in cradle and hook USB cable that came with system into it.
8. Run USB cable over to (006-765ICM) control module and plug into USB port that show's a tablet

Optional Harvest Tec Display Kit (030-7670DK)

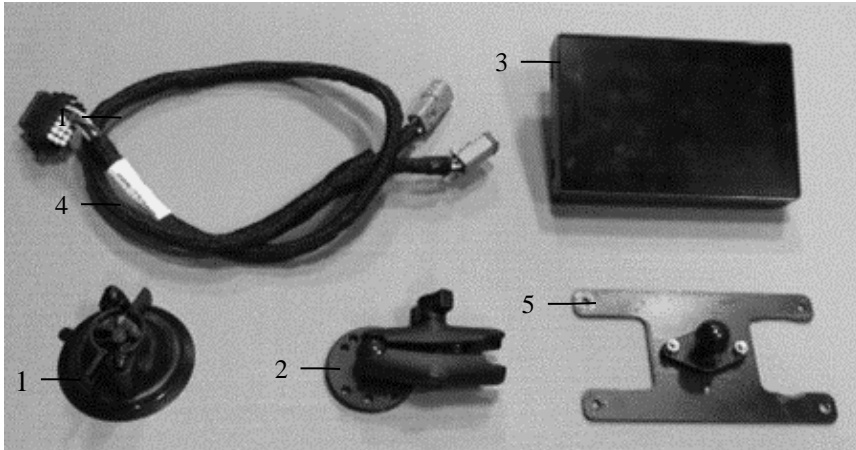

<u>Ref</u>	<u>Description</u>	<u>Part #</u>	<u>Qty</u>
1	Suction Cup Mount	001-2012SCM	1
2	Ram Mount	001-2012H	1
3	Harvest Tec Display	006-765GVT	1
4	Display Harness	006-765GH	1
5	Mounting Plate	001-700GH	1

Installation Instructions

1. Identify 006-765GH harness connection to 006-765IC tractor harness.
2. Connect harness to the Harvest Tec Display before tightening into place.
3. Tighten the mounting and display. Streamline harness, as necessary.
4. Once connected, power cycle system and ensure display is working properly.

NOTE: CANNOT OPERATE WITH BOTH HARVEST TEC DISPLAY AND BALER VT CONNECTED AT THE SAME TIME

4490C Installation Kit

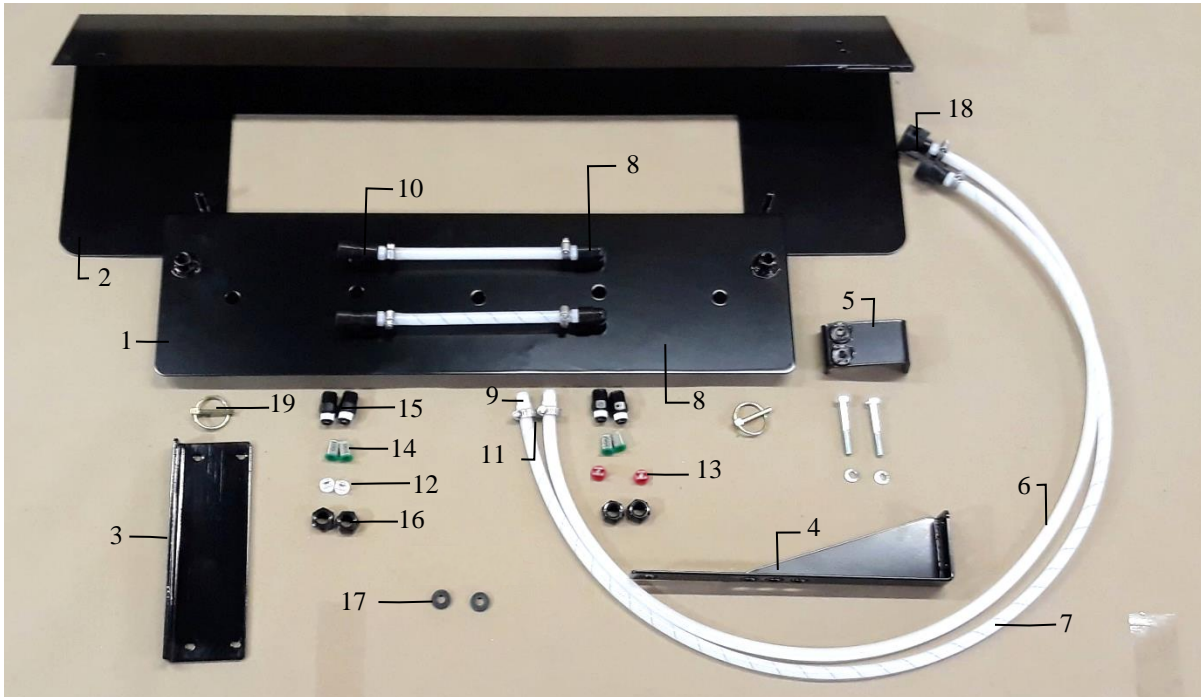

<u>Ref</u>	<u>Description</u>	<u>Part #</u>	<u>Qty</u>	<u>Ref</u>	<u>Description</u>	<u>Part #</u>	<u>Qty</u>
1	Spray Shield	001-4421B	1	11	Mini Hose Clamp	003-9002	8
2	Shield Mounting Bracket	001-4421	1	12	1/4" Tip	004-XR11008VK	2
3	Hesston End of Bale Bracket	001-4648H	1	13	1/4" Tip	004-XR11004VK	2
4	End of Bale Bracket	001-4648	1	14	Tip Strainer-100 Mesh	004-1203-100	4
5	Backing Plate	001-4421A	1	15	Nozzle Body	004-4722	4
6	1/4" Braided Hose	002-9016	5	16	Nozzle Cap	004-4723	4
7	1/4" Braided Hose-Blue	002-9016B	5	17	Rubber Washer	004-1207W	2
8	1/4" Elbow Fitting	003-SE14F	2	18	Female Quick Connect	004-1207H	2
9	1/4" x 1/4" Straight Fitting	003-A1414	8	19	3/16" Lynch Pin	008-4576	2
10	1/4" Tee Fitting	003-TT14SQ	2				

Complete Installation Kit
(Ref. 1-19)

030-4490C

4491C Installation Kit

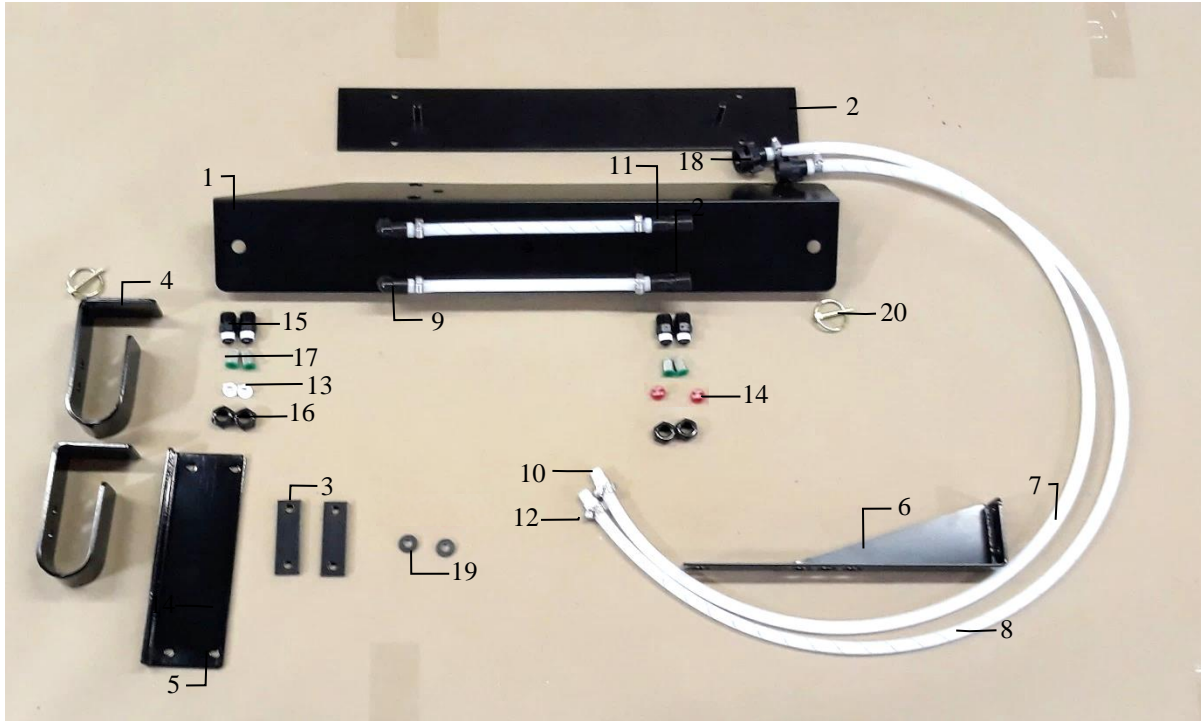

<u>Ref</u>	<u>Description</u>	<u>Part #</u>	<u>Qty</u>	<u>Ref</u>	<u>Description</u>	<u>Part #</u>	<u>Qty</u>
1	Spray Shield	001-4422	1	11	1/4" Tee Fitting	003-TT14SQ	2
2	Shield Mounting Bracket	001-4422B	1	12	Mini Hose Clamp	003-9002	8
3	Backing Plate	001-4422A	2	13	1/4" Tip	004-XR11008VK	2
4	Ladder Holder	001-6707H	2	14	1/4" Tip	004-XR11004VK	2
5	Hesston End of Bale Bracket	001-4648H	1	15	Nozzle Body	004-4722	4
6	End of Bale Bracket	001-4648	1	16	Nozzle Cap	004-4723	4
7	1/4" Braided Hose	002-9016	5	17	Tip Strainer-100 Mesh	004-1203-100	4
8	1/4" Braided Hose - Blue	002-9016B	5	18	Female Quick Connect	004-1207H	2
9	1/4" Elbow Fitting	003-SE14F	2	19	Rubber Washer	004-1207W	2
10	1/4" x 1/4" Straight Fitting	003-A1414	8	20	3/16" Lynch Pin	008-4576	2

Complete Installation Kit
(Ref. 1-20)

030-4491C

4492C Installation Kit

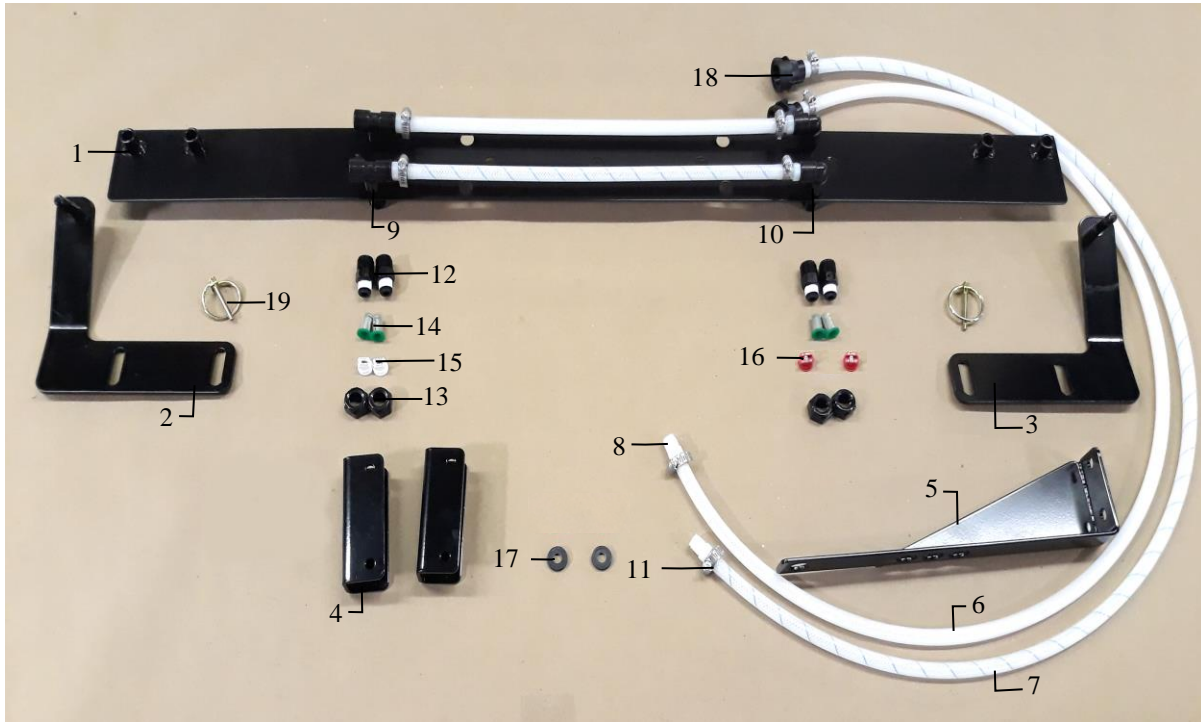

<u>Ref</u>	<u>Description</u>	<u>Part #</u>	<u>Qty</u>	<u>Ref</u>	<u>Description</u>	<u>Part #</u>	<u>Qty</u>
1	Spray Shield	001-4811A	1	11	Mini Hose Clamp	003-9002	8
2	LH Shield Holder	001-4436DL	1	12	Nylon Nozzle Body	004-4722	4
3	RH Shield Holder	001-4436DR	1	13	Nylon Nozzle Cap	004-4723	4
4	Spray Shield Spacer	001-4436S	2	14	Tip Strainer	004-1203-100	4
5	End of Bale Bracket	001-4648	1	15	1/4" Tip	004-XR11008VK	2
6	1/4" Braided Hose	002-9016	5.5	16	1/4" Tip	004-XR11004VK	2
7	1/4" Braided Hose – Blue	002-9016B	5.5	17	Rubber Washer	004-1207W	2
8	1/4" x 1/4" Straight Fitting	003-A1414	8	18	Female Quick Connect	004-1207H	2
9	1/4" Tee Fitting	003-TT14SQ	2	19	3/16" Lynch Pin	008-4576	2
10	1/4" Elbow Fitting	003-SE14F	2				

Complete Installation Kit
(Ref. 1-19)

030-4492C

4494C Installation Kit

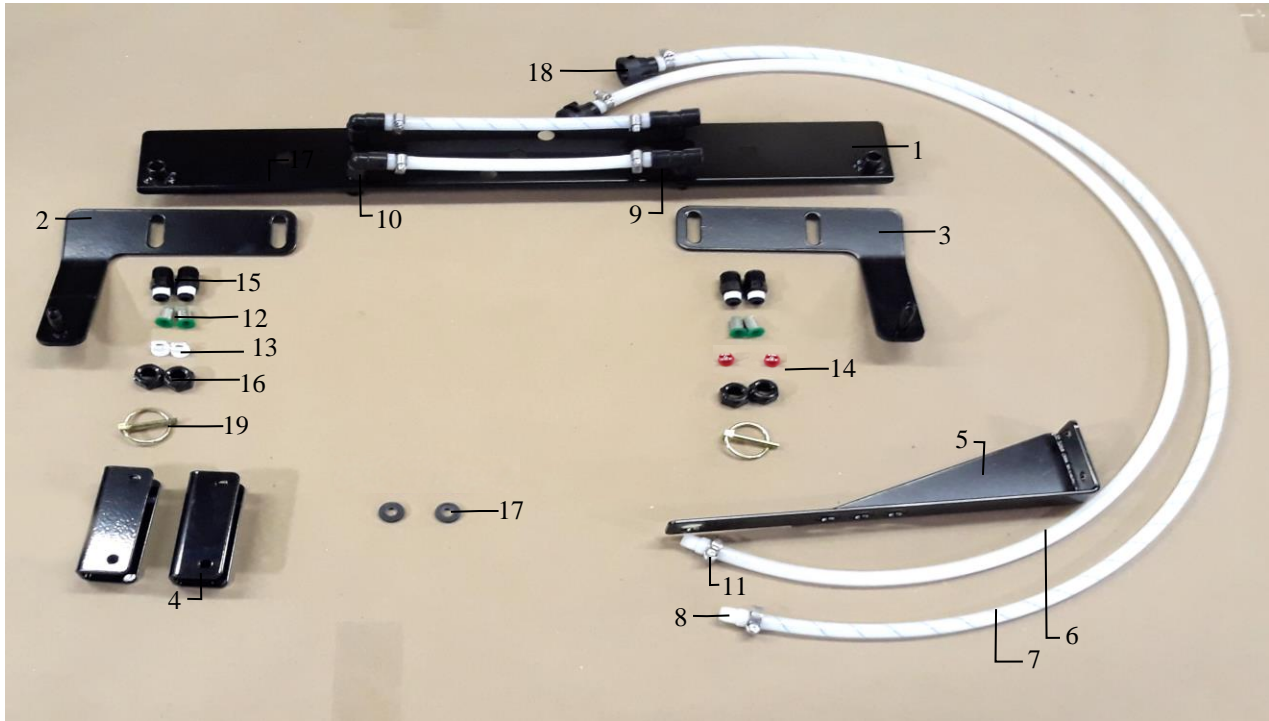

<u>Ref</u>	<u>Description</u>	<u>Part #</u>	<u>Qty</u>	<u>Ref</u>	<u>Description</u>	<u>Part #</u>	<u>Qty</u>
1	Spray Shield	001-4810	1	11	Mini Hose Clamp	003-9002	8
2	LH Shield Holder	001-4436DL	1	12	Tip Strainer-100 Mesh	004-1203-100	4
3	RH Shield Holder	001-4436DR	1	13	1/4" Tip	004-XR11008VK	2
4	Spray Shield Spacer	001-4436S	2	14	1/4" Tip	004-XR11004VK	2
5	End of Bale Bracket	001-4648	1	15	Nylon Nozzle Body	004-4722	4
6	1/4" Braided Hose	002-9016	5	16	Nylon Nozzle Cap	004-4723	4
7	1/4" Braided Hose – Blue	002-9016B	5	17	Rubber Washer	004-1207W	2
8	1/4" x 1/4" Straight Fitting	003-A1414	8	18	Female Quick Connect	004-1207H	2
9	1/4" Tee Fitting	003-TT14SQ	2	19	3/16" Lynch Pin	008-4576	2
10	1/4" Elbow Fitting	003-SE14F	2				

Complete Installation Kit
(Ref. 1-19) 030-4494C

4495C Installation Kit

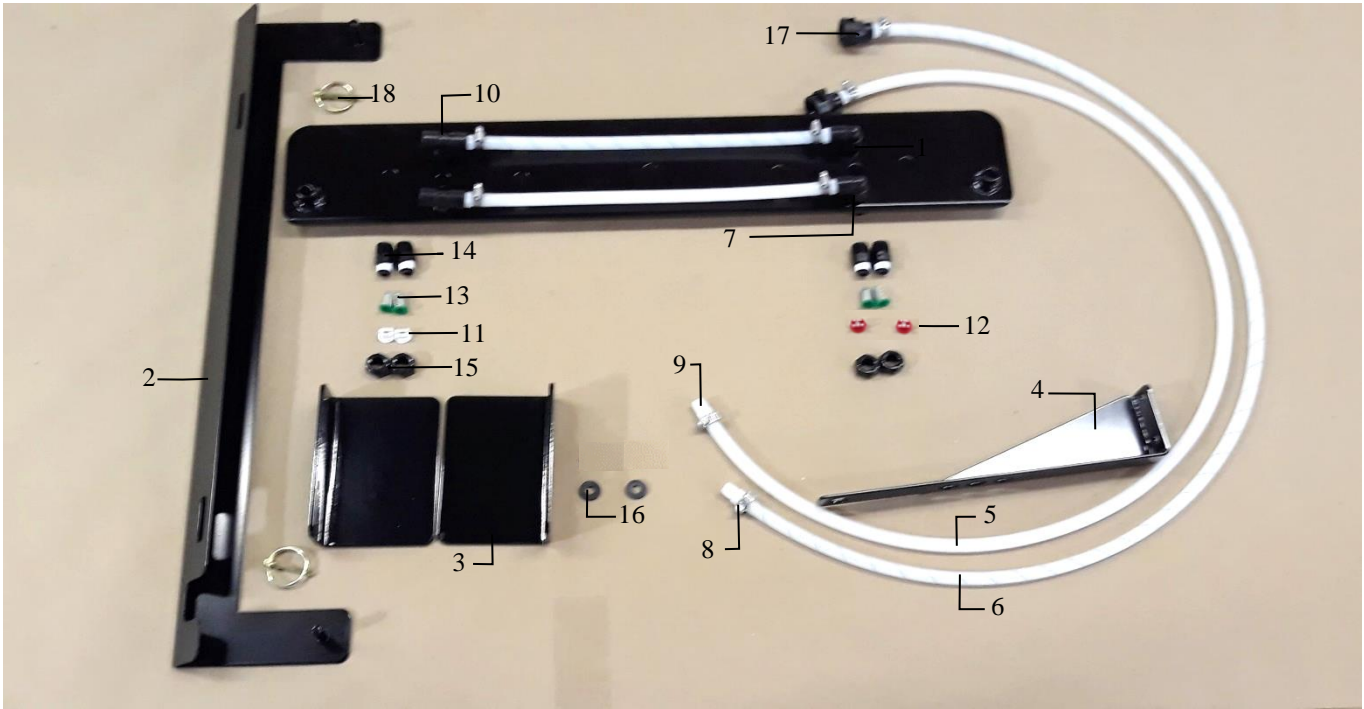

<u>Ref</u>	<u>Description</u>	<u>Part #</u>	<u>Qty</u>	<u>Ref</u>	<u>Description</u>	<u>Part #</u>	<u>Qty</u>
1	Spray Shield	001-4431	1	10	1/4" Tee Fitting	003-TT14SQ	2
2	Spray Shield Holder	001-4431B	1	11	1/4" Tip	004-XR11008VK	2
3	Wind Guard Stops	001-4431D	2	12	1/4" Tip	004-XR11004VK	2
4	End of Bale Bracket	001-4648	1	13	Tip Strainer-100 Mesh	004-1203-100	4
5	1/4" Braided Hose	002-9016	5	14	Nylon Nozzle Body	004-4722	4
6	1/4" Braided Hose-Blue	002-9016B	5	15	Nylon Nozzle Cap	004-4723	4
7	1/4" 90 Deg. Elbow	003-SE14F	2	16	Rubber Washer	004-1207W	2
8	Mini Hose Clamp	003-9002	8	17	Female Quick Connect	004-1207H	2
9	1/4" x 1/4" Straight Fitting	003-A1414	8	18	3/16" Lynch Pin	008-4576	2

Complete Installation Kit
(Ref. 1-18)

030-4495C

4497C Installation Kit

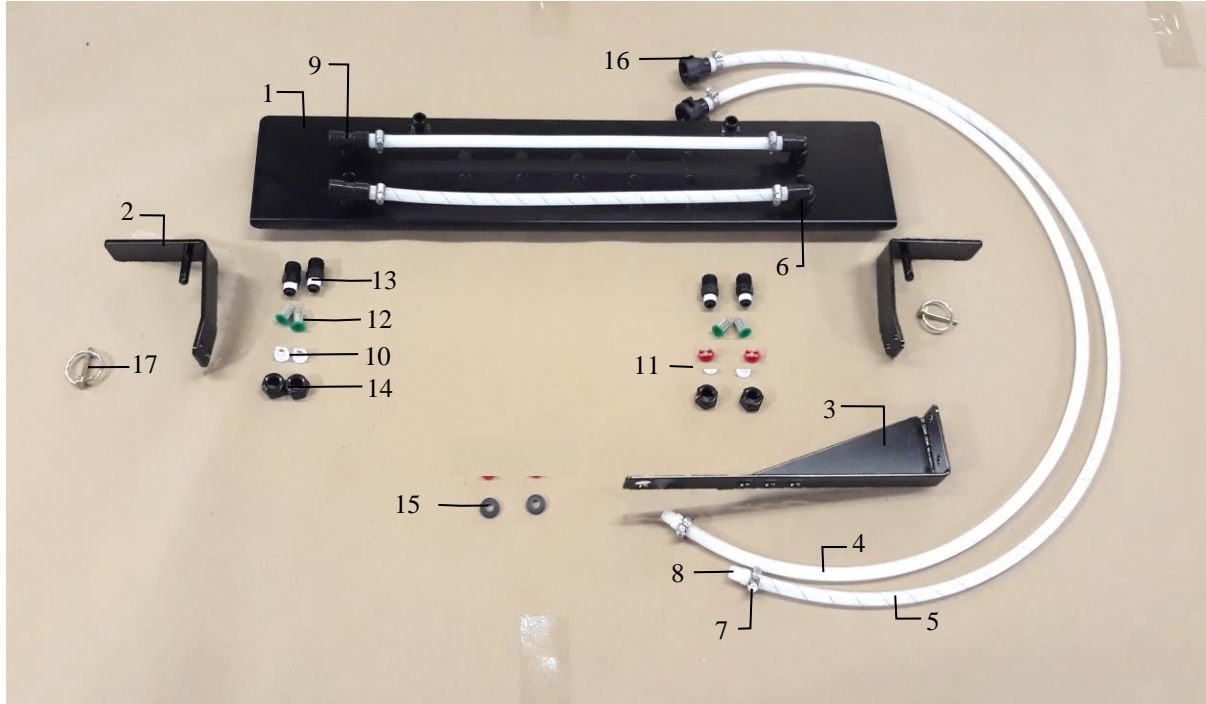

<u>Ref</u>	<u>Description</u>	<u>Part #</u>	<u>Qty</u>	<u>Ref</u>	<u>Description</u>	<u>Part #</u>	<u>Qty</u>
1	Spray Shield	001-4435ES	1	10	1/4" Tip	004-XR11008VK	2
2	Spray Shield Holder	001-4435E	2	11	1/4" Tip	004-XR11004VK	2
3	End of Bale Bracket	001-4648	1	12	Tip Strainer-100 Mesh	004-1203-100	4
4	1/4" Braided Hose	002-9016	5.5	13	Nylon Nozzle Body	004-4722	4
5	1/4" Braided Hose-Blue	002-9016B	5.5	14	Nylon Nozzle Cap	004-4723	4
6	1/4" 90 Deg. Elbow	003-SE14F	2	15	Rubber Washer	004-1207W	2
7	Mini Hose Clamp	003-9002	8	16	Female Quick Connect	004-1207H	2
8	1/4" x 1/4" Straight Fitting	003-A1414	8	17	3/16" Lynch Pin	008-4576	2
9	1/4" Tee Fitting	003-TT14SQ	2				

Complete Installation Kit
(Ref. 1-17)

030-4497C

4498C Installation Kit

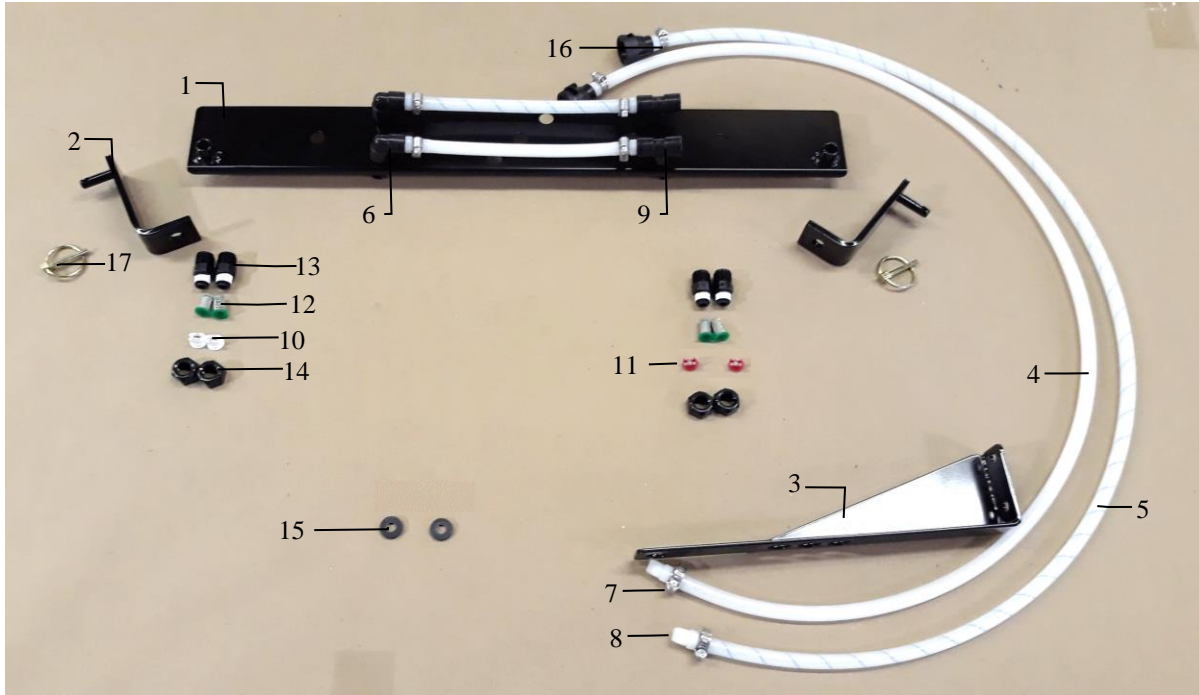

<u>Ref</u>	<u>Description</u>	<u>Part #</u>	<u>Qty</u>	<u>Ref</u>	<u>Description</u>	<u>Part #</u>	<u>Qty</u>
1	Spray Shield	001-4810	1	10	1/4" Tip	004-XR11008VK	2
2	Spray Shield Holder	001-4810A	2	11	1/4" Tip	004-XR11004VK	2
3	End of Bale Bracket	001-4648	1	12	Tip Strainer-100 Mesh	004-1203-100	4
4	1/4" Braided Hose	002-9016	5	13	Nylon Nozzle Body	004-4722	4
5	1/4" Braided Hose - Blue	002-9016B	5	14	Nylon Nozzle Cap	004-4723	4
6	1/4" 90 Deg. Elbow	003-SE14F	2	15	Rubber Washer	004-1207W	2
7	Mini Hose Clamp	003-9002	8	16	Female Quick Connect	004-1207H	2
8	1/4" x 1/4" Straight Fitting	003-A1414	8	17	3/16" Lynch Pin	008-4576	2
9	1/4" Tee Fitting	003-TT14SQ	2				

Complete Installation Kit
(Ref. 1-17)

030-4498C

4499C Installation Kit

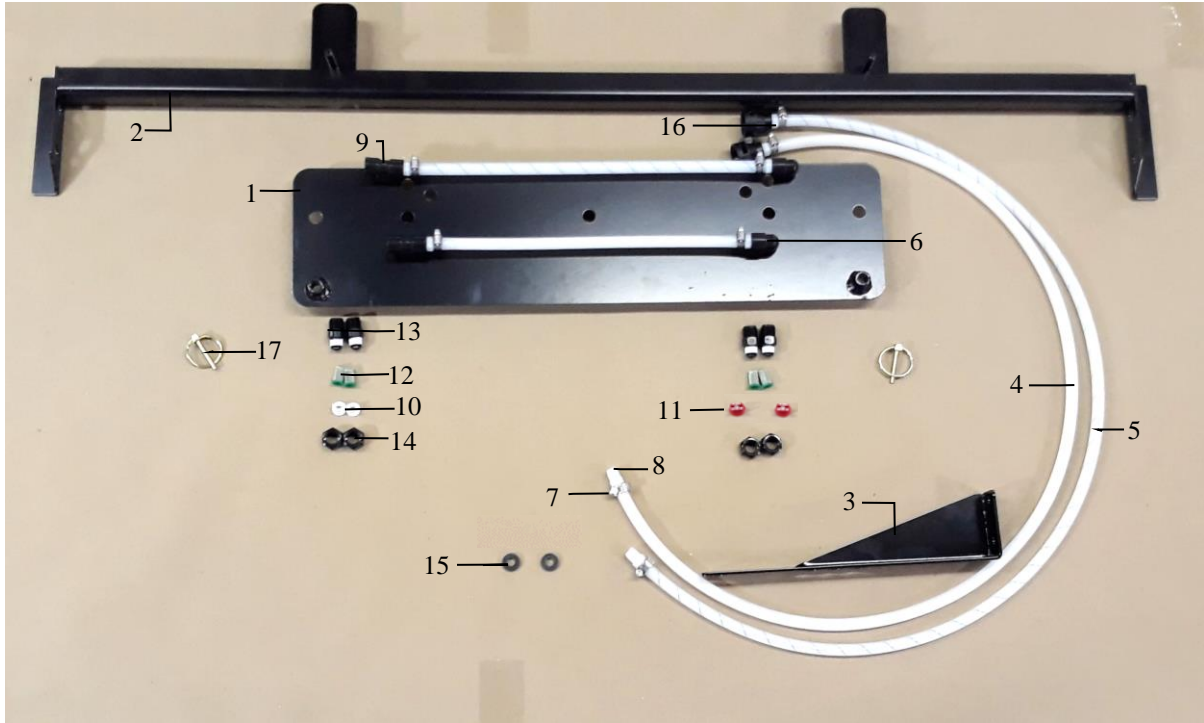

<u>Ref</u>	<u>Description</u>	<u>Part #</u>	<u>Qty</u>	<u>Ref</u>	<u>Description</u>	<u>Part #</u>	<u>Qty</u>
1	Spray Shield	001-4439A	1	10	1/4" Tip	004-XR11008VK	2
2	Spray Shield Holder	001-4440	1	11	1/4" Tip	004-XR11004VK	2
3	End of Bale Bracket	001-4648	1	12	Tip Strainer-100 Mesh	004-1203-100	4
4	1/4" Braided Hose	002-9016	5	13	Nylon Nozzle Body	004-4722	4
5	1/4" Braided Hose - Blue	002-9016B	5.5	14	Nylon Nozzle Cap	004-4723	4
6	1/4" 90 Deg. Elbow	003-SE14F	2	15	Rubber Washer	004-1207W	2
7	Mini Hose Clamp	003-9002	8	16	Female Quick Connect	004-1207H	2
8	1/4" x 1/4" Straight Fitting	003-A1414	8	17	3/16" Lynch Pin	008-4576	2
9	1/4" Tee Fitting	003-TT14SQ	2				
Complete Installation Kit (Ref. 1-17)						030-4499C	

4500C Installation Kit

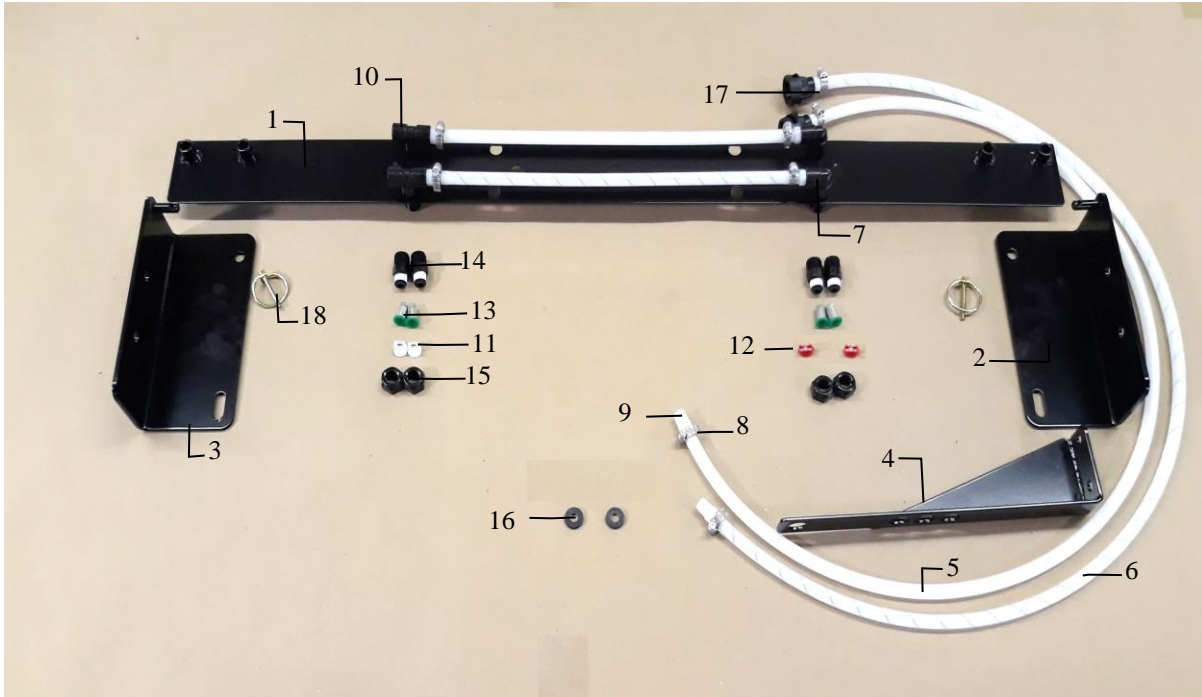

<u>Ref</u>	<u>Description</u>	<u>Part #</u>	<u>Qty</u>	<u>Ref</u>	<u>Description</u>	<u>Part #</u>	<u>Qty</u>
1	Spray Shield	001-4811A	1	10	1/4" Tee Fitting	003-TT14SQ	2
2	RH Mount Bracket	001-4436CR	1	11	1/4" Tip	004-XR11008VK	2
3	LH Mount Bracket	001-4436CL	1	12	1/4" Tip	004-XR11004VK	2
4	End of Bale Bracket	001-4648	1	13	Tip Strainer-100 Mesh	004-1203-100	4
5	1/4" Braided Hose	002-9016	5.5	14	Nylon Nozzle Body	004-4722	4
6	1/4" Braided Hose - Blue	002-9016B	5.5	15	Nylon Nozzle Cap	004-4723	4
7	1/4" 90 Deg. Elbow	003-SE14F	2	16	Rubber Washer	004-1207W	2
8	Mini Hose Clamp	003-9002	6	17	Female Quick Connect	004-1207H	2
9	1/4" x 1/4" Straight Fitting	003-A1414	6	18	3/16" Lynch Pin	008-4576	2

Complete Installation Kit
(Ref. 1-18)

030-4500C

4501C Installation Kit

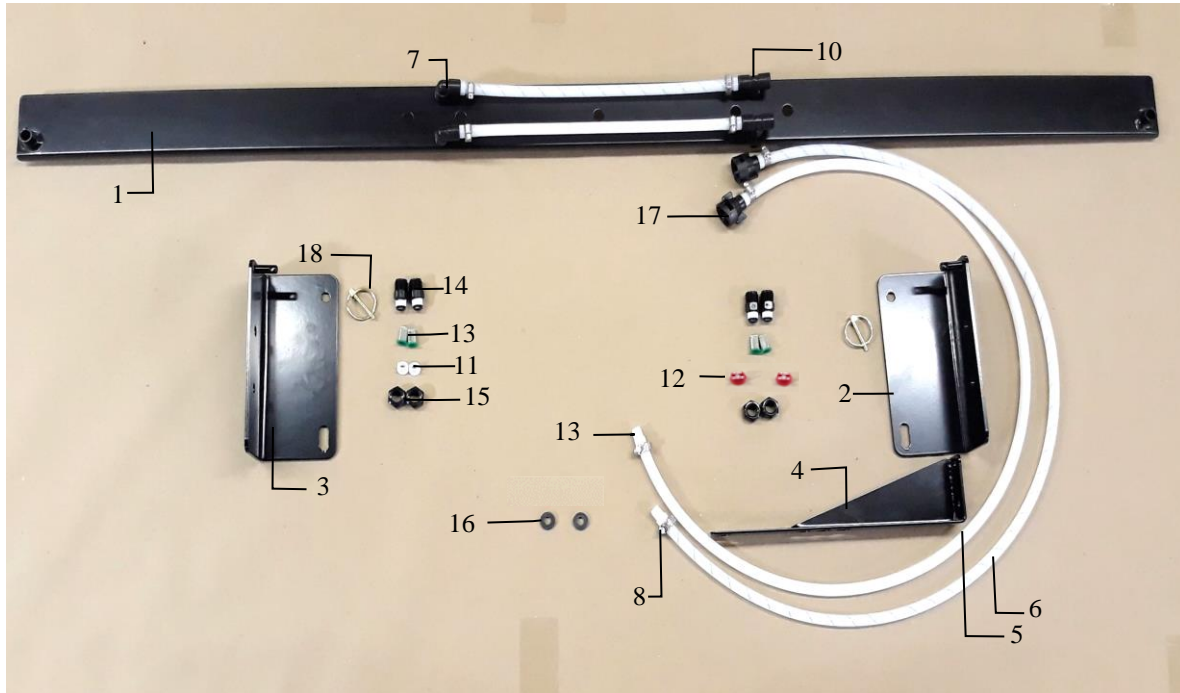

<u>Ref</u>	<u>Description</u>	<u>Part #</u>	<u>Qty</u>	<u>Ref</u>	<u>Description</u>	<u>Part #</u>	<u>Qty</u>
1	Spray Shield	001-4436CS	1	10	1/4" Tee Fitting	003-TT14SQ	2
2	RH Mount Bracket	001-4436CR	1	11	1/4" Tip	004-XR11008VK	2
3	LH Mount Bracket	001-4436CL	1	12	1/4" Tip	004-XR11004VK	2
4	End of Bale Bracket	001-4648	1	13	Tip Strainer-100 Mesh	004-1203-100	4
5	1/4" Braided Hose	002-9016	4	14	Nylon Nozzle Body	004-4722	4
6	1/4" Braided Hose – Blue	002-9016B	4	15	Nylon Nozzle Cap	004-4723	4
7	1/4" 90 Deg. Elbow	003-SE14F	2	16	Rubber Washer	004-1207W	2
8	Mini Hose Clamp	003-9002	8	17	Female Quick Connect	004-1207H	2
9	1/4" x 1/4" Straight Fitting	003-A1414	8	18	3/16" Lynch Pin	008-4576	2

Complete Installation Kit
(Ref. 1-18)

030-4501C

4509C Installation Kit

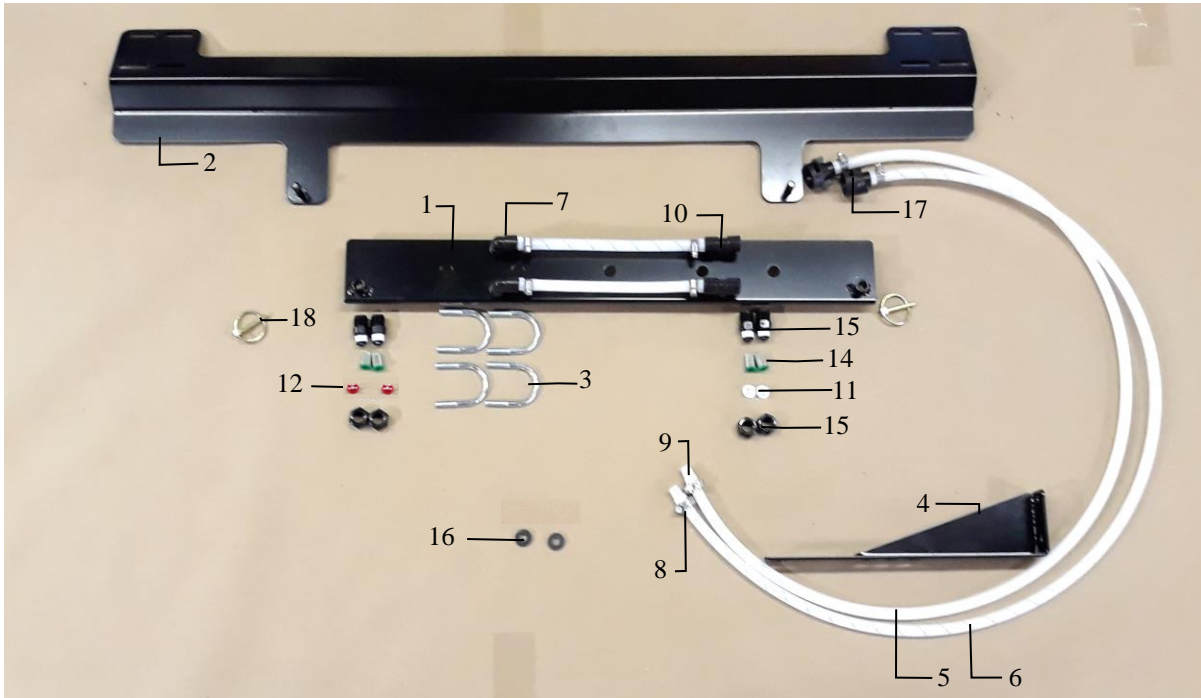

<u>Ref</u>	<u>Description</u>	<u>Part #</u>	<u>Qty</u>	<u>Ref</u>	<u>Description</u>	<u>Part #</u>	<u>Qty</u>
1	Spray Shield	001-4810	1	10	1/4" Tee Fitting	003-TT14SQ	2
2	Spray Shield Holder	001-4440A	1	11	1/4" Tip	004-XR11008VK	2
3	U Bolt	001-4714UBS	4	12	1/4" Tip	004-XR11004VK	2
4	End of Bale Bracket	001-4648	1	13	Tip Strainer-100 Mesh	004-1203-100	4
5	1/4" Braided Hose	002-9016	5	14	Nylon Nozzle Body	004-4722	4
6	1/4" Braided Hose – Blue	002-9016B	5	15	Nylon Nozzle Cap	004-4723	4
7	1/4" 90 Deg. Elbow	003-SE14F	2	16	Rubber Washer	004-1207W	2
8	Mini Hose Clamp	003-9002	6	17	Female Quick Connect	004-1207H	2
9	1/4" x 1/4" Straight Fitting	003-A1414	6	18	3/16" Lynch Pin	008-4576	2

Complete Installation Kit
(Ref. 1-18)

030-4509C

4510C Installation Kit

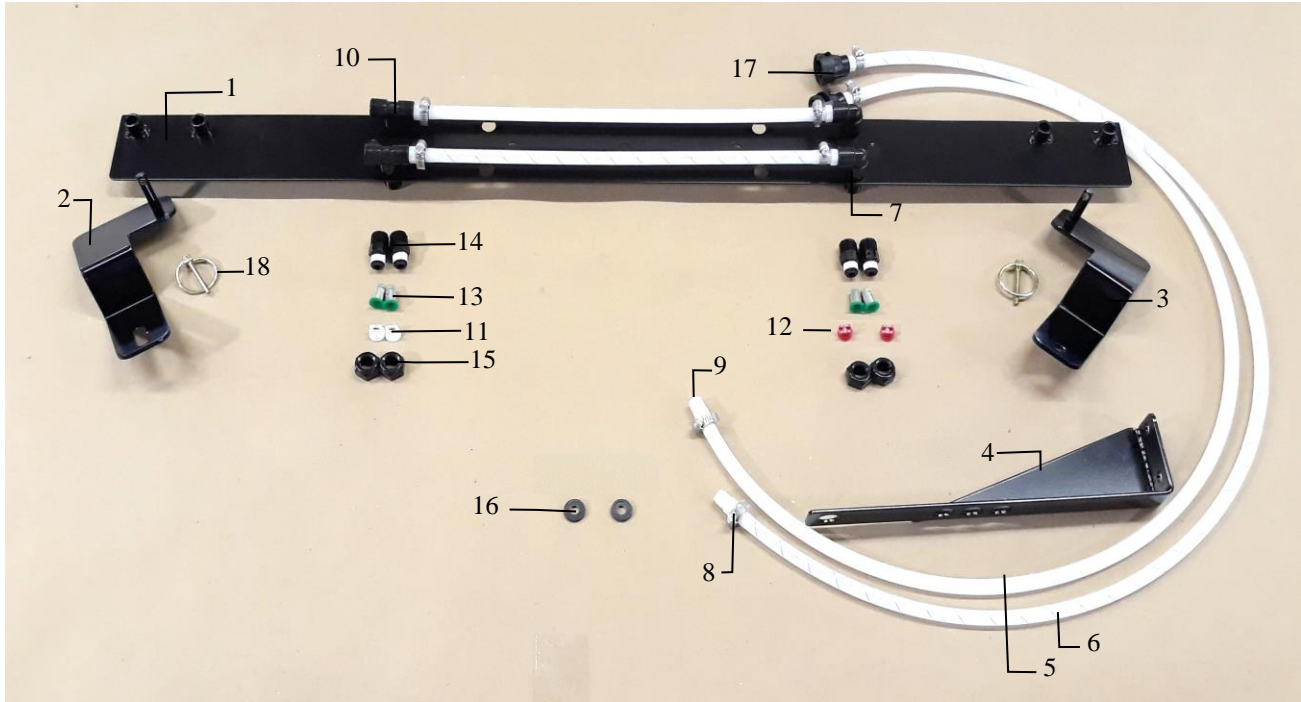

<u>Ref</u>	<u>Description</u>	<u>Part #</u>	<u>Qty</u>	<u>Ref</u>	<u>Description</u>	<u>Part #</u>	<u>Qty</u>
1	Spray Shield	001-4811A	1	10	1/4" Tee Fitting	003-TT14SQ	2
2	RH Shield Bracket	001-4704B	1	11	1/4" Tip	004-XR11008VK	2
3	LH Shield Bracket	001-4704A	1	12	1/4" Tip	004-XR11004VK	2
4	End of Bale Bracket	001-4648	1	13	Tip Strainer-100 Mesh	004-1203-100	4
5	1/4" Braided Hose	002-9016	5.5	14	Nylon Nozzle Body	004-4722	4
6	1/4" Braided Hose – Blue	002-9016B	5.5	15	Nylon Nozzle Cap	004-4723	4
7	1/4" 90 Deg. Elbow	003-SE14F	2	16	Rubber Washer	004-1207W	2
8	Mini Hose Clamp	003-9002	8	17	Female Quick Connect	004-1207H	2
9	1/4" x 1/4" Straight Fitting	003-A1414	8	18	3/16" Lynch Pin	008-4576	2

Complete Installation Kit
(Ref. 1-18)

030-4510C

4511C Installation Kit

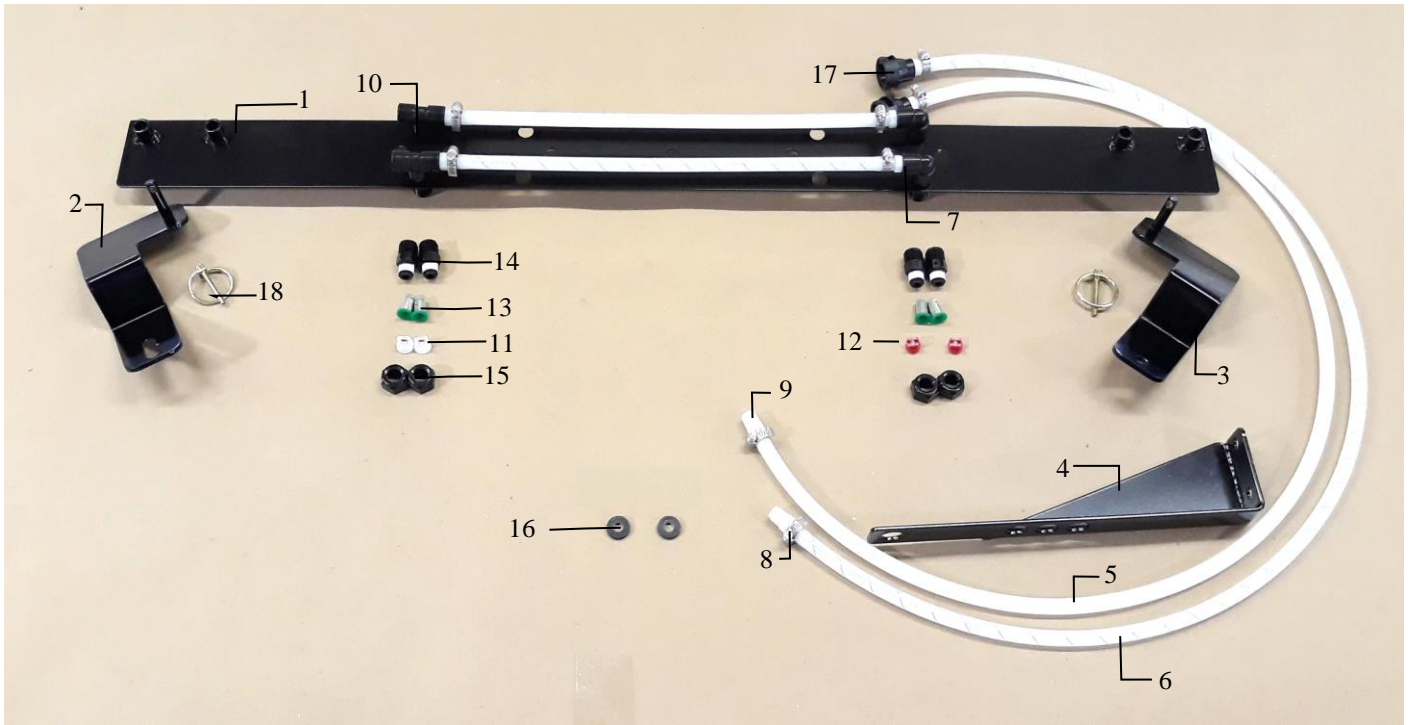

<u>Ref</u>	<u>Description</u>	<u>Part #</u>	<u>Qty</u>	<u>Ref</u>	<u>Description</u>	<u>Part #</u>	<u>Qty</u>
1	Spray Shield	001-4704C	1	10	1/4" Tee Fitting	003-TT14SQ	2
2	RH Shield Bracket	001-4704B	1	11	1/4" Tip	004-XR11008VK	2
3	LH Shield Bracket	001-4704A	1	12	1/4" Tip	004-XR11004VK	2
4	End of Bale Bracket	001-4648	1	13	Tip Strainer-100 Mesh	004-1203-100	4
5	1/4" Braided Hose	002-9016	5.5	14	Nylon Nozzle Body	004-4722	4
6	1/4" Braided Hose – Blue	002-9016B	5.5	15	Nylon Nozzle Cap	004-4723	4
7	1/4" 90 Deg. Elbow	003-SE14F	2	16	Rubber Washer	004-1207W	2
8	Mini Hose Clamp	003-9002	8	17	Female Quick Connect	004-1207H	2
9	1/4" x 1/4" Straight Fitting	003-A1414	8	18	3/16" Lynch Pin	008-4576	2

Complete Installation Kit
(Ref. 1-18)

030-4511C

4514C Installation Kit

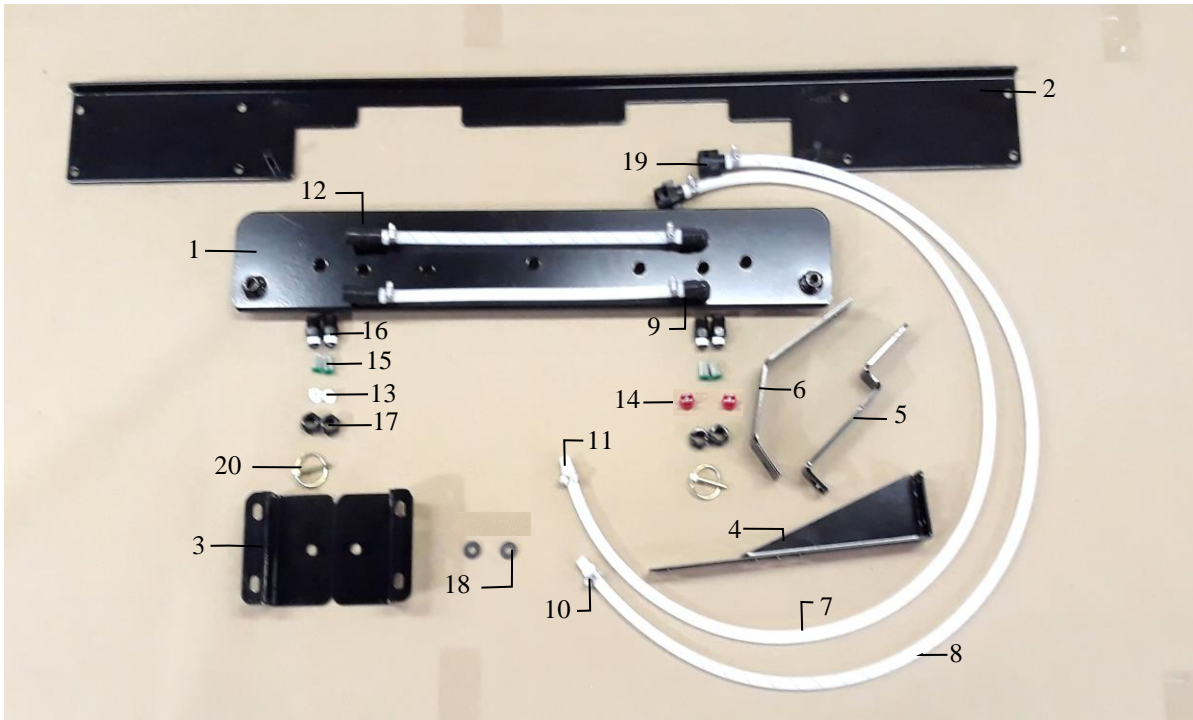

<u>Ref</u>	<u>Description</u>	<u>Part #</u>	<u>Qty</u>	<u>Ref</u>	<u>Description</u>	<u>Part #</u>	<u>Qty</u>
1	Spray Shield	001-4431B	1	11	1/4" x 1/4" Straight Fitting	003-A1414	8
2	Spray Shield Holder	001-4431KA	1	12	1/4" Tee Fitting	003-TT14SQ	2
3	Shield Mounting Bracket	001-4431KB	2	13	1/4" Tip	004-XR11008VK	2
4	End of Bale Bracket	001-4648	1	14	1/4" Tip	004-XR11004VK	2
5	End of Bale Bracket	001-4648K	1	15	Tip Strainer-100 Mesh	004-1203-100	4
6	End of Bale Bracket	001-4648K2	1	16	Nylon Nozzle Body	004-4722	4
7	1/4" Braided Hose	002-9016	5	17	Nylon Nozzle Cap	004-4723	4
8	1/4" Braided Hose – Blue	002-9016B	5	18	Rubber Washer	004-1207W	2
9	1/4" 90 Deg. Elbow	003-SE14F	2	19	Female Quick Connect	004-1207H	2
10	Mini Hose Clamp	003-9002	8	20	3/16" Lynch Pin	008-4576	2

Complete Installation Kit
(Ref. 1-20)

030-4514C

Model 4515C Installation Kit

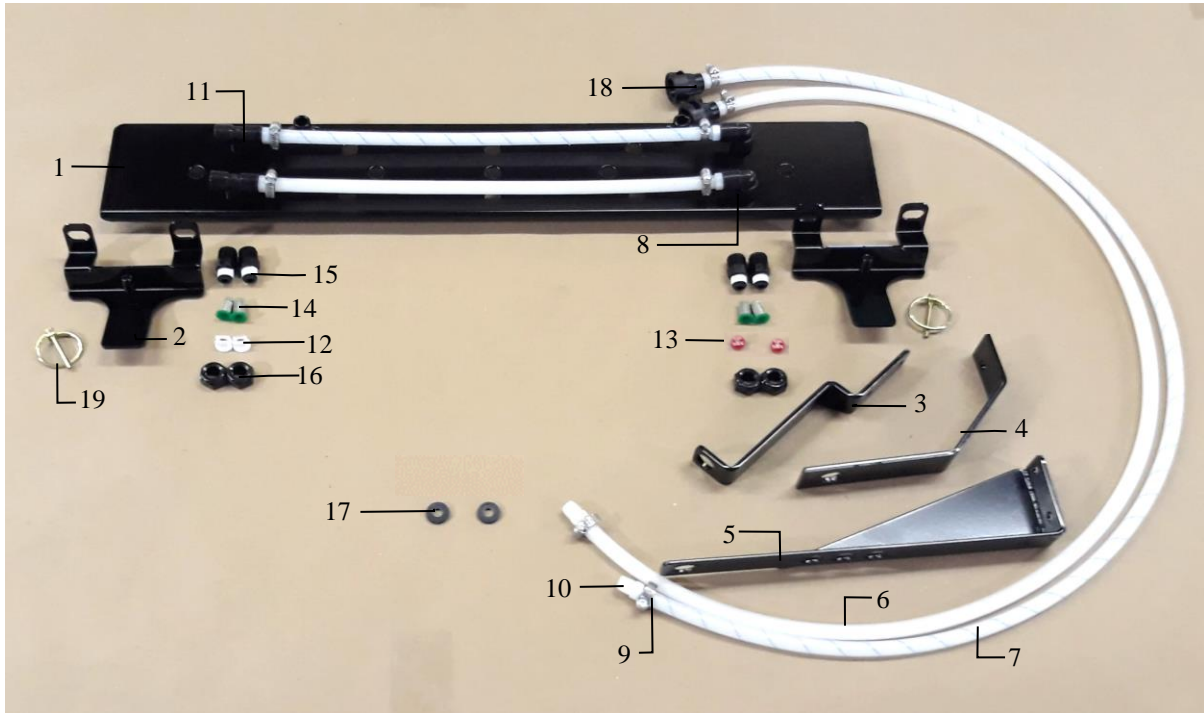

<u>Ref</u>	<u>Description</u>	<u>Part #</u>	<u>Qty</u>	<u>Ref</u>	<u>Description</u>	<u>Part #</u>	<u>Qty</u>
1	Spray Shield	001-4435AS	1	11	1/4" Tee Fitting	003-TT14SQ	2
2	Spray Shield Holder	001-4435KS	2	12	1/4" Tip	004-XR11008VK	2
3	Krone End of Bale Bracket	001-4648K	1	13	1/4" Tip	004-XR11004VK	2
4	Krone End of Bale Bracket	001-4648K2	1	14	Tip Strainer-100 Mesh	004-1203-100	4
5	End of Bale Bracket	001-4648	1	15	Nylon Nozzle Body	004-4722	4
6	1/4" Braided Hose	002-9016	5.5	16	Nylon Nozzle Cap	004-4723	4
7	1/4" Braided Hose-Blue	002-9016B	5.5	17	Rubber Washer	004-1207W	2
8	1/4" 90 Deg. Elbow	003-SE14F	2	18	Female Quick Connect	004-1207H	2
9	Mini Hose Clamp	003-9002	8	19	3/16" Lynch Pin	008-4576	2
10	1/4" x 1/4" Straight Fitting	003-A1414	8				

Complete Installation Kit
(Ref. 1-19)

030-4515C

Model 4525C Installation Kit

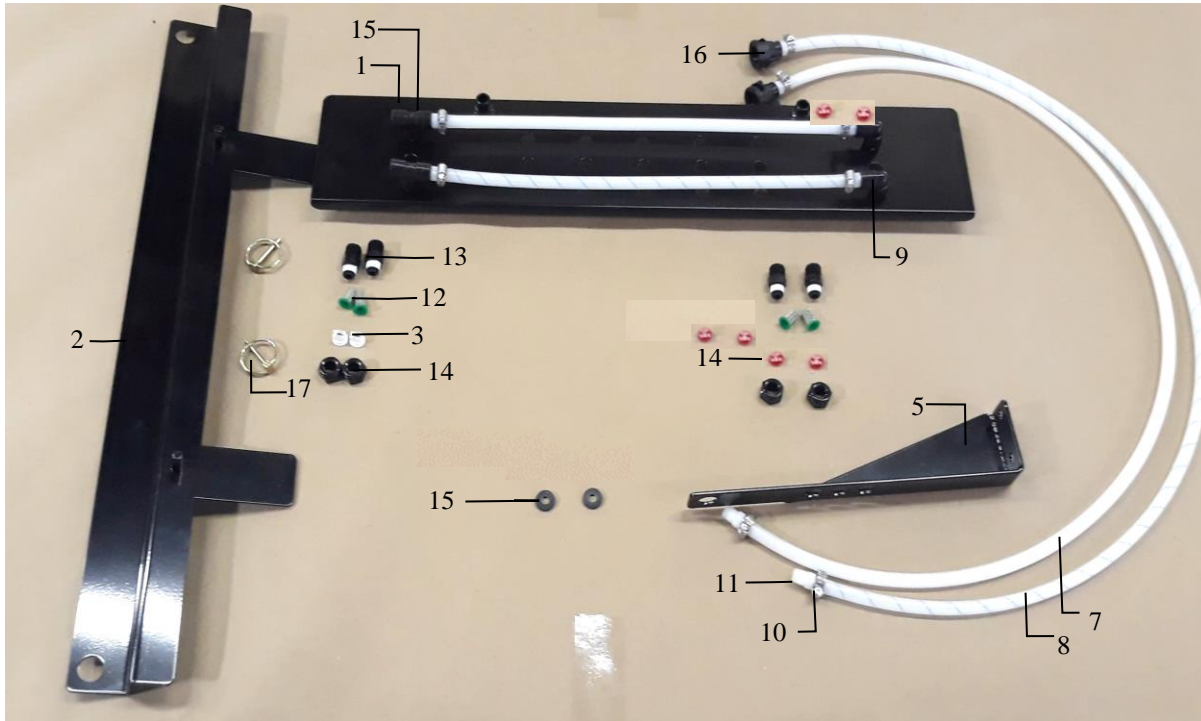

<u>Ref</u>	<u>Description</u>	<u>Part #</u>	<u>Qty</u>	<u>Ref</u>	<u>Description</u>	<u>Part #</u>	<u>Qty</u>
1	Spray Shield	001-4435ES	1	10	1/4" Tip	004-XR11008VK	2
2	Shield Mounting Bracket	001-4435EK	1	11	1/4" Tip	004-XR11004VK	2
3	EOB Sensor Bracket	001-4648	1	12	Tip Strainer-100 Mesh	004-1203-100	4
4	1/4" Braided Hose	002-9016	5.5	13	Nylon Nozzle Body	004-4722	4
5	1/4" Braided Hose-Blue	002-9016B	5.5	14	Nylon Nozzle Cap	004-4723	4
6	1/4" 90 Deg. Elbow	003-SE14F	2	15	Rubber Washer	004-1207W	2
7	Mini Hose Clamp	003-9002	8	16	Female Quick Connect	004-1207H	2
8	1/4" x 1/4" Straight Fitting	003-A1414	8	17	3/16" Lynch Pin	008-4576	2
9	1/4" Tee Fitting	003-TT14SQ	2				

Complete Installation Kit
(Ref. 1-17)

030-4525C

4529C Installation Kit

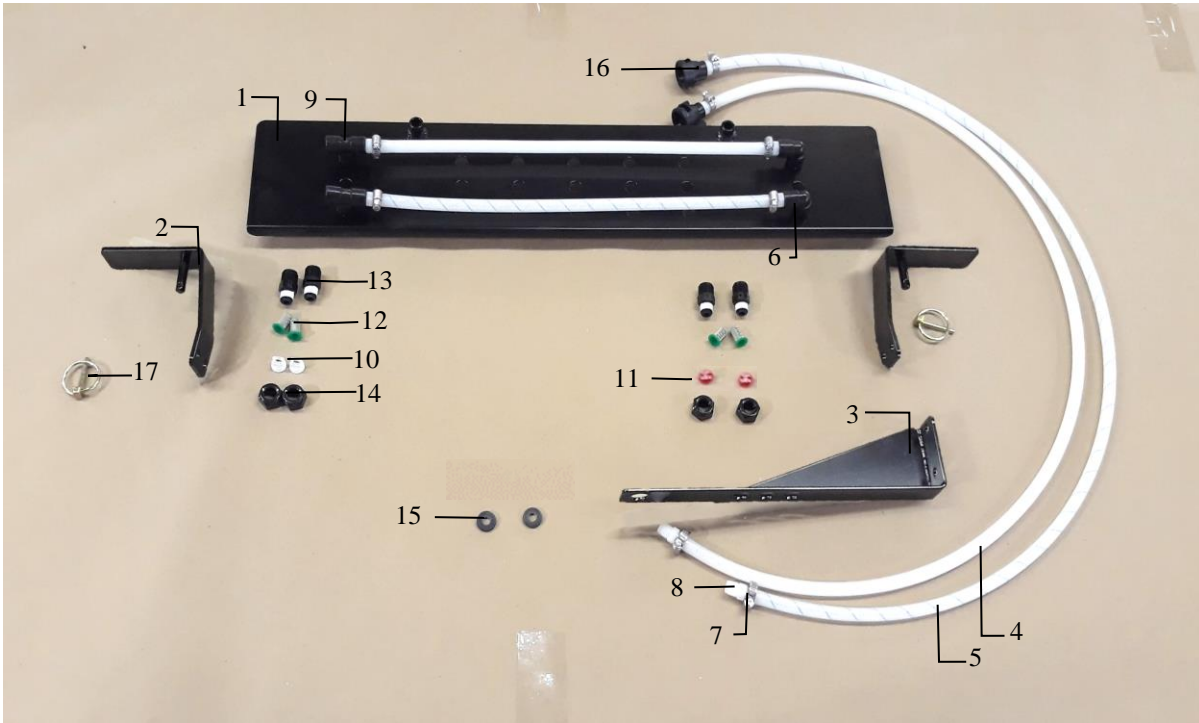

<u>Ref</u>	<u>Description</u>	<u>Part #</u>	<u>Qty</u>	<u>Ref</u>	<u>Description</u>	<u>Part #</u>	<u>Qty</u>
1	Spray Shield	001-4435ES	1	10	1/4" Tip	004-XR11008VK	2
2	Shield Mounting Bracket	001-4435E	2	11	1/4" Tip	004-XR11004VK	2
3	End of Bale Bracket	001-4648	1	12	Tip Strainer-100 Mesh	004-1203-100	4
4	1/4" Braided Hose	002-9016	5.5	13	Nylon Nozzle Body	004-4722	4
5	1/4" Braided Hose-Blue	002-9016B	5.5	14	Nylon Nozzle Cap	004-4723	4
6	1/4" 90 Deg. Elbow	003-SE14F	2	15	Rubber Washer	004-1207W	2
7	Mini Hose Clamp	003-9002	8	16	Female Quick Connect	004-1207H	2
8	1/4" x 1/4" Straight Fitting	003-A1414	8	17	3/16" Lynch Pin	008-4576	2
9	1/4" Tee Fitting	003-TT14SQ	2				

Complete Installation Kit
(Ref. 1-17)

030-4529C

4537C Installation Kit

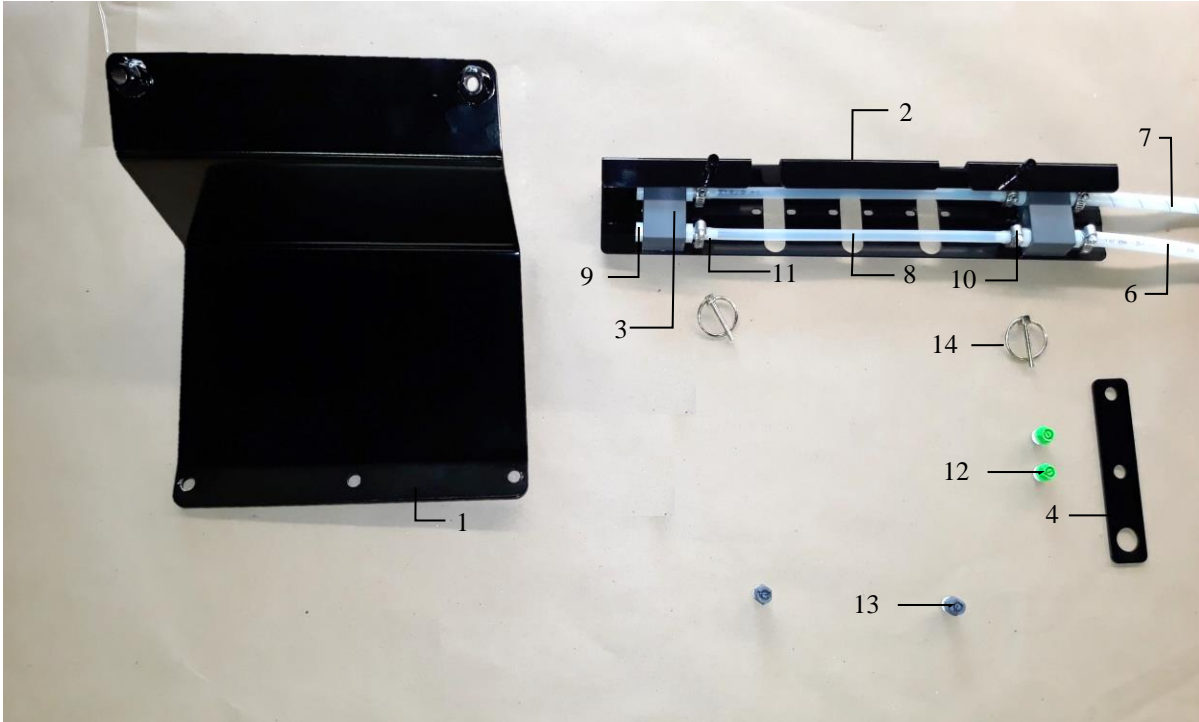

<u>Ref</u>	<u>Description</u>	<u>Part #</u>	<u>Qty</u>	<u>Ref</u>	<u>Description</u>	<u>Part #</u>	<u>Qty</u>
1	Spray Shied Holder	001-4435L	2	9	1/4" Hex Plug	003-F14	2
2	Spray Shield	001-4435NSX	1	10	Mini Hose Clamp	003-9002	4
3	Spray Shield Block	001-4435NSB	2	11	1/4" x 1/4" Straight Fitting	003-A1414	8
4	Claas End of Bale Bracket	001-4648C	1	12	1/4" NPT Tip	004-T8008-PT	2
6	1/4" Braided Hose	002-9016	4	13	1/4" NPT Tip	004-T8004-PT	2
7	1/4" Braided Hose - Blue	002-9016B	4	14	3/16" Lynch Pin	008-4576	2
8	1/4" EVA Tubing	002-9006	3	NP	Rubber Washer	004-1207W	2
				NP	Female Quick Connect	004-1207H	2

Complete Installation Kit 030-4537C
(Ref. 1-14)

4539C Installation Kit

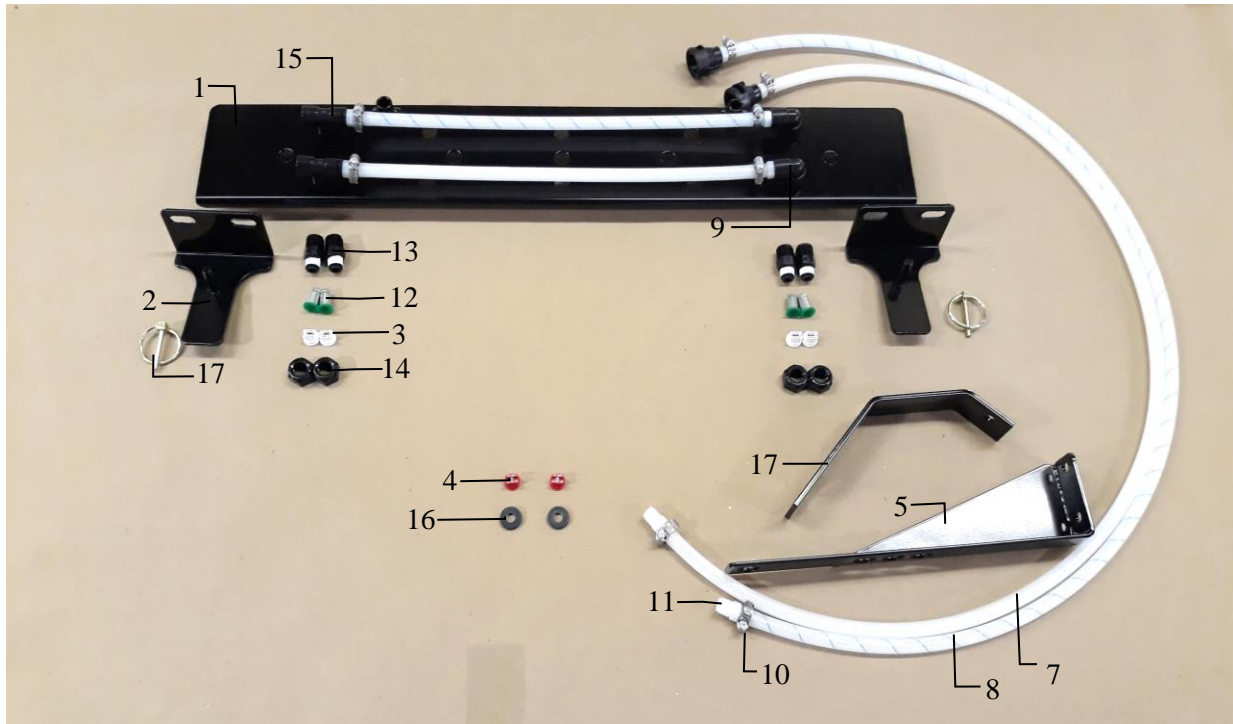

<u>Ref</u>	<u>Description</u>	<u>Part #</u>	<u>Qty</u>	<u>Ref</u>	<u>Description</u>	<u>Part #</u>	<u>Qty</u>
1	Spray Shield	001-4435AS	1	10	1/4" Tee Fitting	003-TT14SQ	2
2	Shield Mounting Bracket	001-4435KX	2	11	1/4" Tip	004-XR11008VK	4
3	End of Bale Bracket	001-4648	1	12	1/4" Tip	004-XR11004VK	2
4	End of Bale Bracket	001-4648K2	1	13	Tip Strainer-100 Mesh	004-1203-100	4
5	1/4" Braided Hose	002-9016	5.5	14	Nylon Nozzle Body	004-4722	4
6	1/4" Braided Hose-Blue	002-9016B	5.5	15	Nylon Nozzle Cap	004-4723	4
7	1/4" 90 Deg. Elbow	003-SE14F	2	16	Rubber Washer	004-1207W	2
8	Mini Hose Clamp	003-9002	8	17	3/16" Lynch Pin	008-4576	2
9	1/4" x 1/4" Straight Fitting	003-A1414	8				

Complete Installation Kit
(Ref. 1-17)

030-4539C

4540C Installation Kit

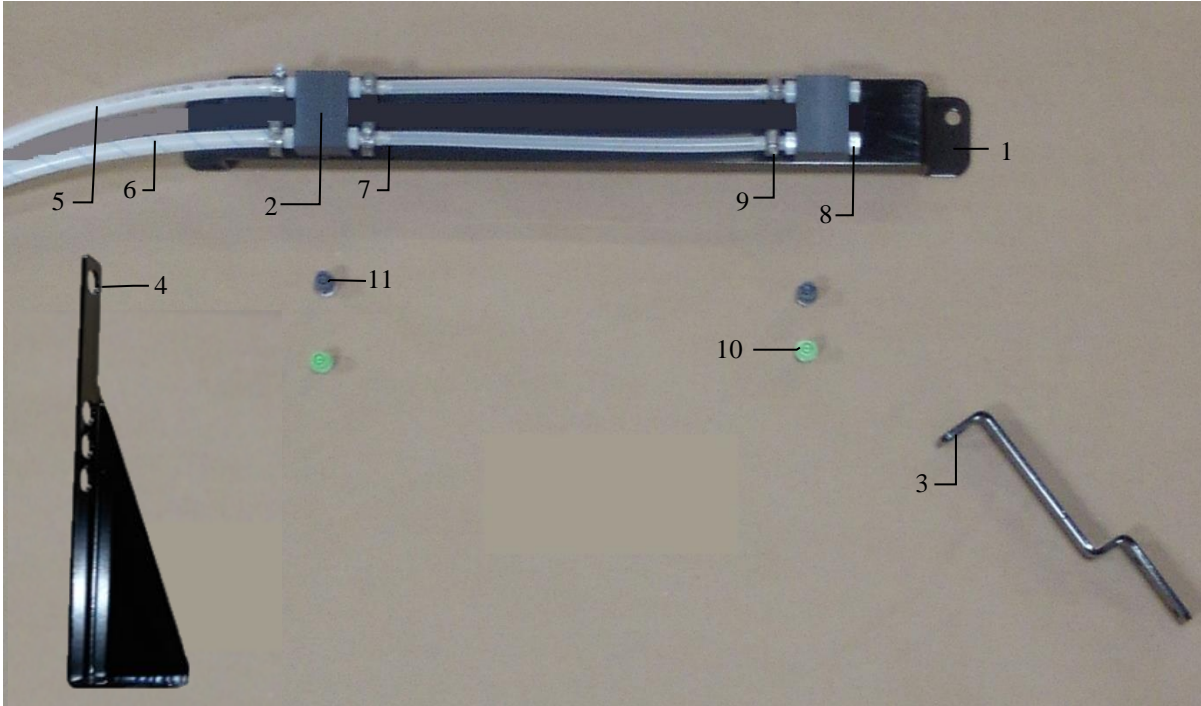

<u>Ref</u>	<u>Description</u>	<u>Part #</u>	<u>Qty</u>	<u>Ref</u>	<u>Description</u>	<u>Part #</u>	<u>Qty</u>
1	Spray Shield	001-4435NSX	1	7	1/4" x 1/4" Straight Fitting	003-A1414	8
2	Spray Shield Block	001-4435NSB	2	8	1/4" Hex Plug	003-F14	2
3	End of Bale Bracket	001-4648	1	9	Mini Hose Clamp	003-9002	4
4	Krone End of Bale Bracket	001-4648K	1	10	1/4" NPT Tip	004-T8008-PT	2
5	1/4" Braided Hose	002-9016	4	11	1/4" NPT Tip	004-T8004-PT	2
NP	Rubber Washer	004-1207W	2	NP	Female Quick Connect	004-1207H	2

Complete Installation Kit 030-4540C
(Ref. 1-11)

4541C Installation Kit

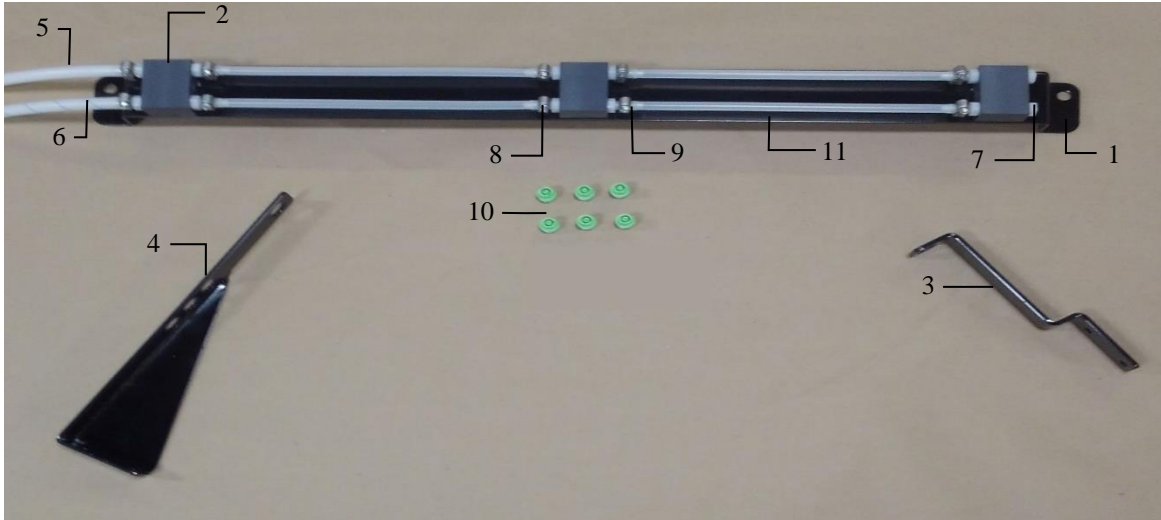

<u>Ref</u>	<u>Description</u>	<u>Part #</u>	<u>Qty</u>	<u>Ref</u>	<u>Description</u>	<u>Part #</u>	<u>Qty</u>
1	Spray Shield	001-4435NSX	1	8	Mini Hose Clamp	003-9002	12
2	Spray Shield Block	001-4435NSB	3	9	1/4" x 1/4" Straight Fitting	003-A1414	12
3	End of Bale Bracket	001-4648	1	10	1/4" NPT Tip	004-T8003-PT	3
4	Krone End of Bale Bracket	001-4648K	1	11	1/4" EVA Tubing	002-9006	4
5	1/4" Braided Hose	002-9016	4	NP	Rubber Washer	004-1207W	2
6	1/4" Braided Hose - Blue	002-9016B	4	NP	Female Quick Connect	004-1207H	2
7	1/4" Hex Plug	003-F14	2	NP	1/4" NPT Tip	004-T8005-PT	5

*Tip color subject to change

Complete Installation Kit 030-4541C
(Ref. 1-11)

Vicon Large Square Star Wheel Guide

Drill 5/16" Diameter holes (x2)

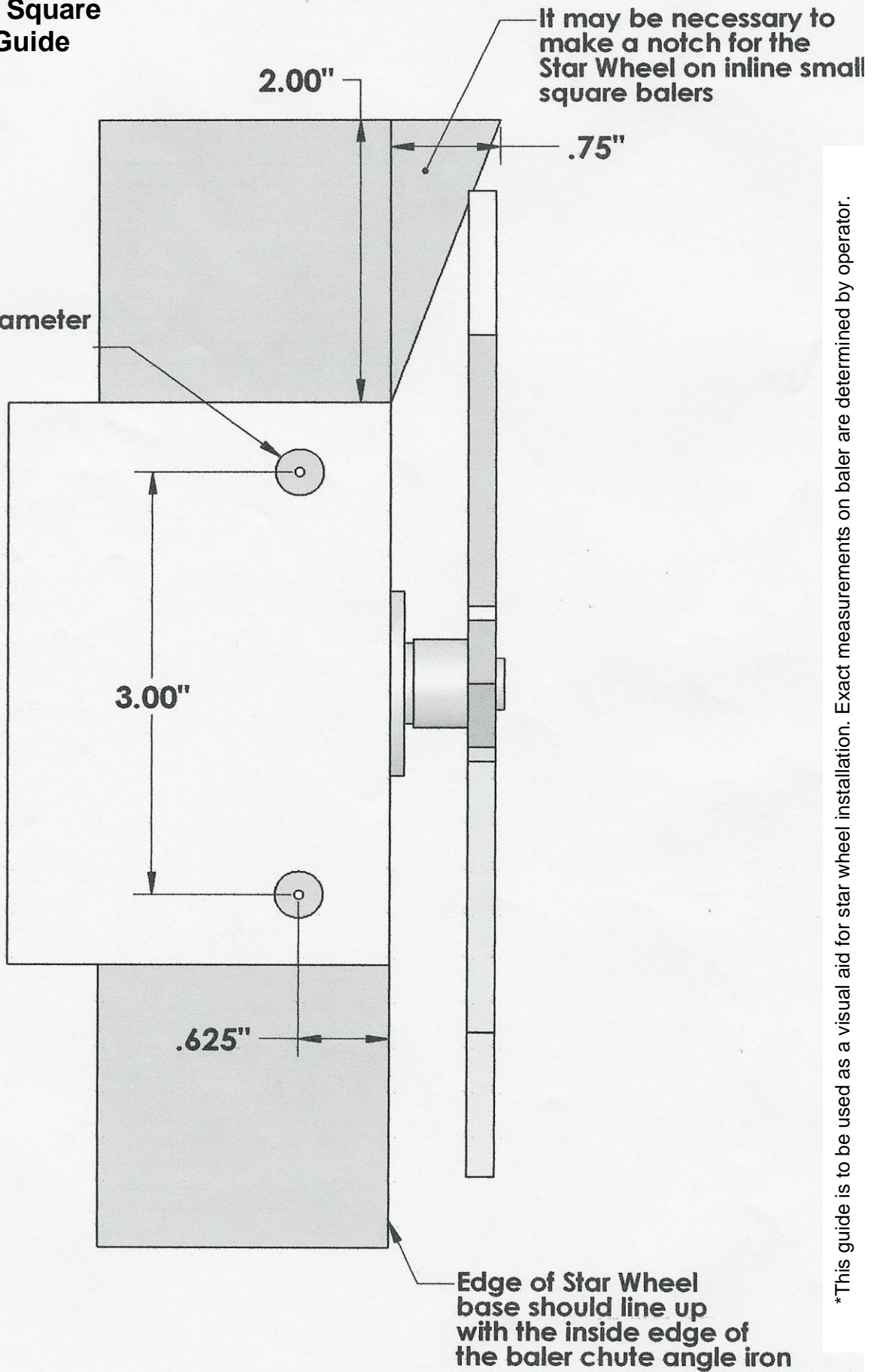

*This guide is to be used as a visual aid for star wheel installation. Exact measurements on baler are determined by operator.

Large Square Star Wheel Guide

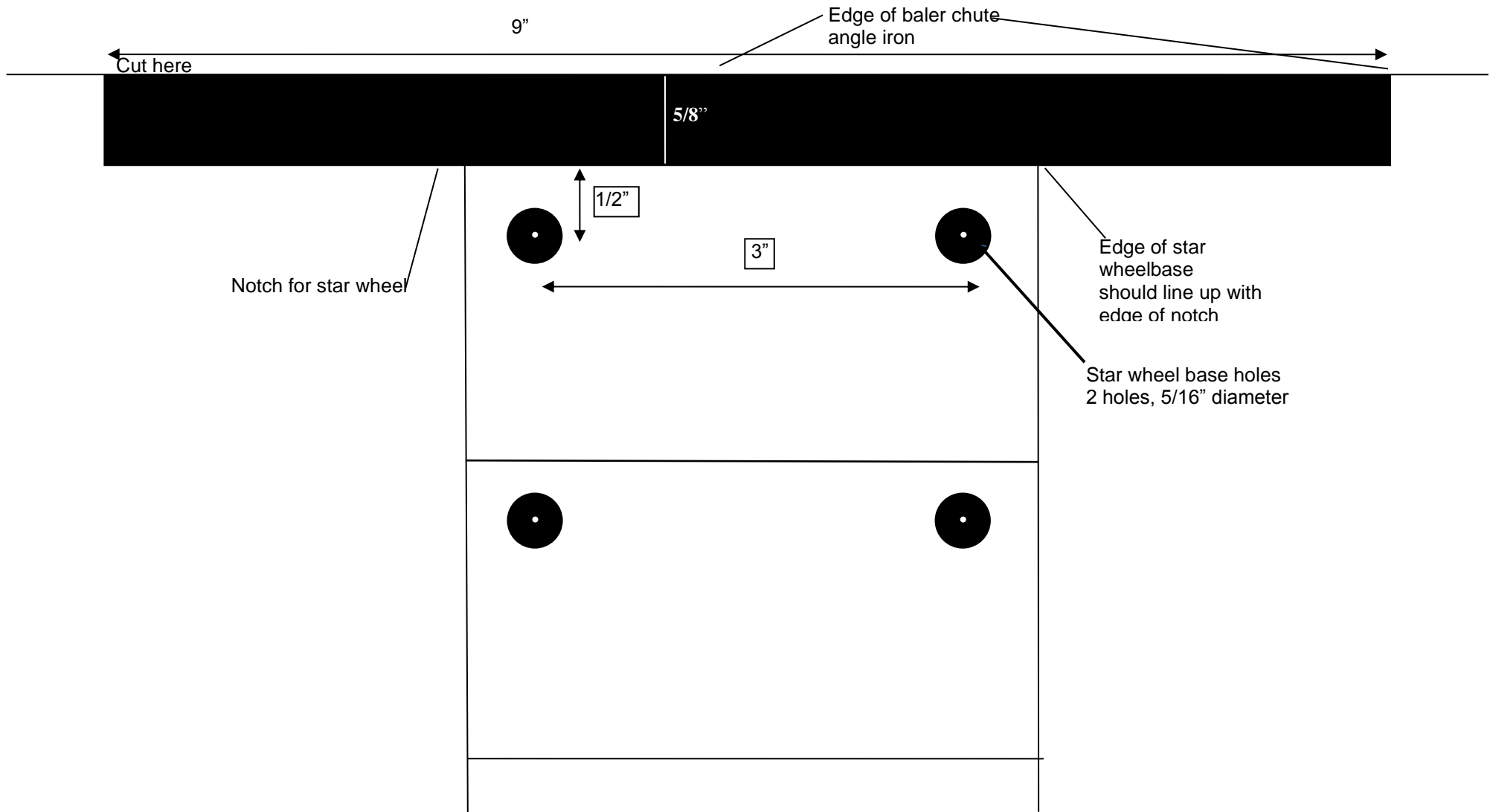

Harvest Tec Inc. Warranty and Liability Agreement

Harvest Tec, Inc. will repair or replace components that are found to be defective within 12 months from the date of manufacture. Under no circumstances does this warranty cover any components which in the opinion of Harvest Tec, Inc. have been subjected to negligent use, misuse, alteration, accident, or if repairs have been made with parts other than those manufactured and obtainable from Harvest Tec, Inc.

Our obligation under this warranty is limited to repairing or replacing free of charge to the original purchaser any part that in our judgment shows evidence of defective or improper workmanship, provided the part is returned to Harvest Tec, Inc. within 30 days of the failure. If it is determined that a non-Harvest Tec branded hay preservative has been used inside the Harvest Tec applicator system where the failure occurred, then Harvest Tec reserves the right to deny the warranty request at their discretion. Parts must be returned through the selling dealer and distributor, transportation charges prepaid.

This warranty shall not be interpreted to render Harvest Tec, Inc. liable for injury or damages of any kind, direct, consequential, or contingent, to persons or property. Furthermore, this warranty does not extend to loss of crop, losses caused by delays or any expense prospective profits or for any other reason. Harvest Tec, Inc. shall not be liable for any recovery greater in amount than the cost or repair of defects in workmanship.

There are no warranties, either expressed or implied, of merchantability or fitness for particular purpose intended or fitness for any other reason.

This warranty cannot guarantee that existing conditions beyond the control of Harvest Tec, Inc. will not affect our ability to obtain materials or manufacture necessary replacement parts.

Harvest Tec, Inc. reserves the right to make design changes, improve design, or change specifications, at any time without any contingent obligation to purchasers of machines and parts previously sold.

Revised 4/17

HARVEST TEC, INC.
P.O. BOX 63
2821 HARVEY STREET
HUDSON, WI 54016
PHONE: 715-386-9100
1-800-635-7468
FAX: 715-381-1792