

Installation Manual

Model 335Z **25 Gallon Automatic Preservative Applicator**



P.O. Box 63 • 2821 Harvey Street • Hudson, WI 54016
800-635-7468 • www.harvesttec.com

DECLARATION OF INCORPORATION



MANUFACTURER:

Harvest Tec Inc.
2821 Harvey St.
P.O. Box 63
Hudson, WI 54016, U.S.A.

REPRESENTATIVE ESTABLISHED IN COMMUNITY: Profitable Farming Company
Middle Barlington, Roborough
Winkleigh, Devon, EX19 8AG
ENGLAND

The person above certifies and declares that:

VIRTUAL MACHINE: Equipment mounted on a farm press and for the application of inoculants onto forage crops.

MODEL: 335Z-21-INST-Imp&Metric

BRAND: Harvest Tec

SERIAL NUMBER:

This application preservatives for hay Harvest Tec system meets the Directive 2006/42/EC of the European Parliament and the Council of 17 May 2006 and other applicable European Directives including Directive 2004/108/EC on the Electromagnetic compatibility.

The application of preservatives for hay Harvest Tec system will be turned on after being installed on a farm press has been declared in conformity with the Machinery Directive.

Person in the community authorized to provide information on the partly completed machinery and making this statement:

Richard Snell, President, Profitable Farming Company
Signed on May 21, 2011: Middle Barlington, Roborough
Winkleigh, Devon, EX19 8AG
ENGLAND

Harvest Tec 335Z Table of Contents

	<u>PAGE</u>
Introduction	3
Tools Needed	3
Installation of Applicator	4-10
Installation of Mounting Brackets and Tank	4-5
Mount Pump Plate Assembly	6
Placement of Spray Nozzle Assembly	7
Installation of Plumbing	7
Installation of Moisture Sensing Pads	8
End of Bale Sensor	9
Installation of iPad Integration Control	10
iPad Integration Control Light Signal	10
Wiring Diagram	11
Pin Outs	12-13
Parts Breakdown	14-23
Base Kit	14-15
Pump Assembly	16
300 Solenoid Package	17
Moisture Sensor	18
Control Box and Wiring Harnesses	19
End of Bale Sensor Kit	19
Parts Bag Packages & Hoses	20
Installation Kit	21
Optional iPad Mounting Kit	22
Optional iPad Display Kit	23
Warranty Statement	24

Introduction

Congratulations and thank you for purchasing a Harvest Tec Model 335Z applicator. Please read this manual carefully to ensure correct steps are taken to attach the applicator to the baler. This applicator is designed to apply Harvest Tec buffered propionic acid. Use of alternative products may cause complications. Including inaccurate readings from the flow meter and damage to all parts. Resulting in the warranty being void. A parts break down for the applicator is located in the back of the manual.

****Made for iPad® (3rd through Pro 2nd generation), running the current iOS operating system or one version previous required for iPad option***

**iPad is a trademark of Apple Inc., registered in the U.S. and other countries.*

Hay App version must be **at least 2.7.1 (or higher)** to operate with the iPad Integration Module (030-6672C)

Tools Needed

- Standard socket set
- Standard screw driver or 5/16" nut driver
- Side cutter
- Hose cutter
- Crescent wrench
- Hammer
- Metal drilling and cutting tools
- Center Punch

Installation of Applicator

Installation of Mounting Brackets and Tank

1. Locate parts 001-4703ZR-A, 001-4703ZR-B, two 001-4703ZR-C and four $\frac{3}{4}$ " x 4 $\frac{1}{2}$ " bolts, lock washers and nut.
2. Line up 001-4703ZR-A and 001-4703ZR-B about 18 inches apart on the ground. Slide part 001-4703ZR-C into square mounts and secure with $\frac{3}{4}$ " x 4 $\frac{1}{2}$ " bolts, locks, and nuts to holed in place. Note there are two sets of $\frac{3}{4}$ " holes on the 001-4703ZR-C. Use the set that is about 18 inches apart.
3. Locate part 001-4703ZR-D1 and two $\frac{1}{2}$ " x 5 $\frac{1}{2}$ " bolts, locks, washers, and nuts. Bolt part 001-4703ZR-D1 to the top of the two 001-4703ZR-C with this hardware.
4. Locate part 001-4703ZR-D2. Bolt to the front of 001-4703ZR-D1 with $\frac{1}{2}$ " x 3 $\frac{1}{2}$ " bolts, washers, locks, and nuts. Do not fully tighten down.
5. Using a lift, bring the assembly up under the cab of the baler. Part 001-4703ZR-D2 should line up with holes in the front part of the baler. Mark the half inch holes at the ends of the 001-4703ZR-A and 001-4703ZR-B that line up with the structural parts under the cab. Lower assembly out of the way and drill these four holes with a $\frac{9}{16}$ " drill bit. (Note. Do not drill into hydraulic lines or electrical wires.)
6. Once holes have been drilled. Lift assembly back up under cab and attach to baler with four $\frac{1}{2}$ " x 3 $\frac{1}{2}$ " bolts, washers on both sides, locks, and nuts. $\frac{3}{4}$ " hardware is provided if you would want to use this. However, part 001-4703ZR-A and 001-4703ZR-B will need to be drilled out for the $\frac{3}{4}$ " bolts. The 001-4703ZR-D2 will attach to the front mount with $\frac{1}{2}$ " x 2" bolts, washers on both sides, locks, and nut.
7. Attach two 001-4703ZR-E to each 001-4703ZR-C (one on each side) sticking out the front of the baler. Use $\frac{3}{4}$ " x 4 $\frac{1}{2}$ " bolts, locks, nuts. Do not fully tighten down yet.
8. Attach 001-4703ZR-G to the 001-4703ZR-E at the height you desire to keep the tank about the windrow. Note the lower the take the closer it is to the windrow coming into the baler. The higher it will obstruct your view. Use $\frac{3}{4}$ " x 4 $\frac{1}{2}$ " bolts, locks, and nuts to secure.
9. Attach 001-4703ZR-G to 001-4703ZR-F with $\frac{1}{2}$ " x 4" Bolts, washers, locks, and nut. Do not fully tighten down. (Note: angles will be pointing toward each other.)
10. Place saddle assembly on 001-4703ZR-G and secure with $\frac{1}{2}$ " washer, locks, and nuts.
11. Tighten all hardware down.

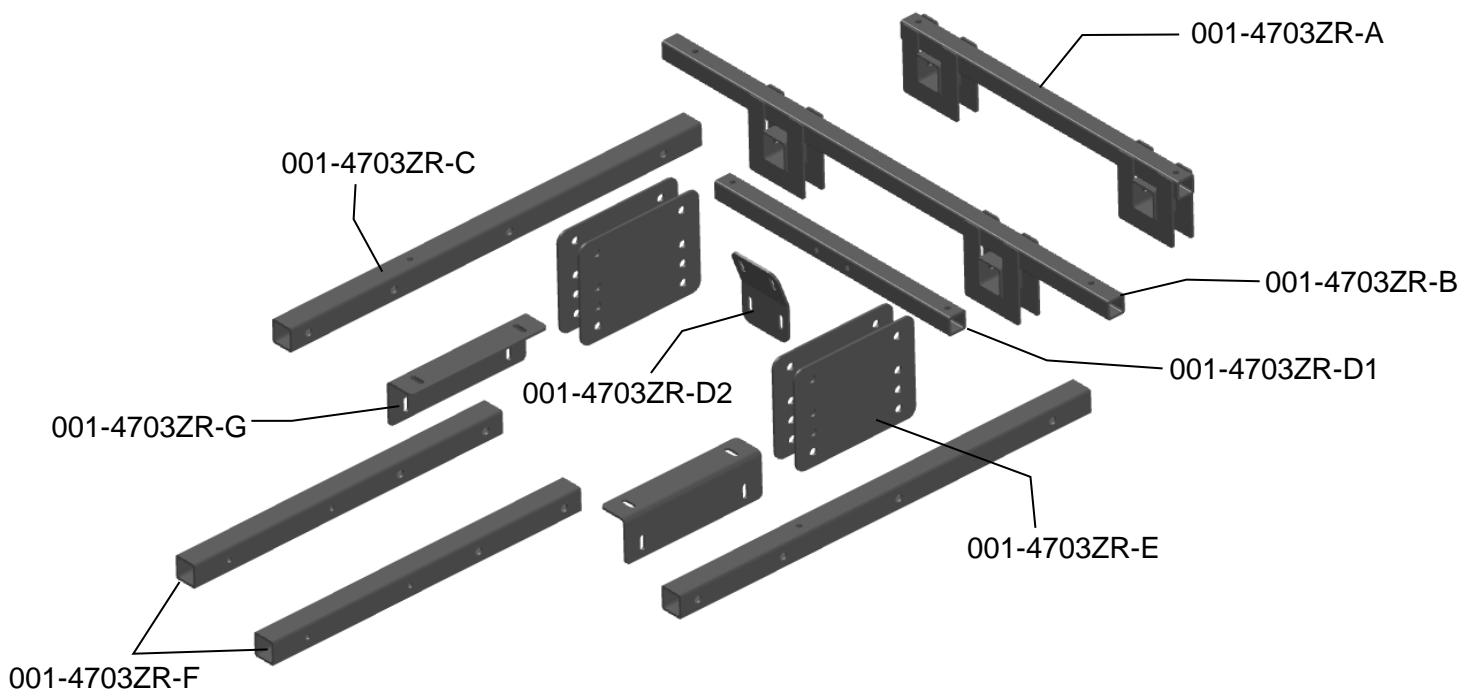

Installation of Mounting Brackets and Tank (continued)

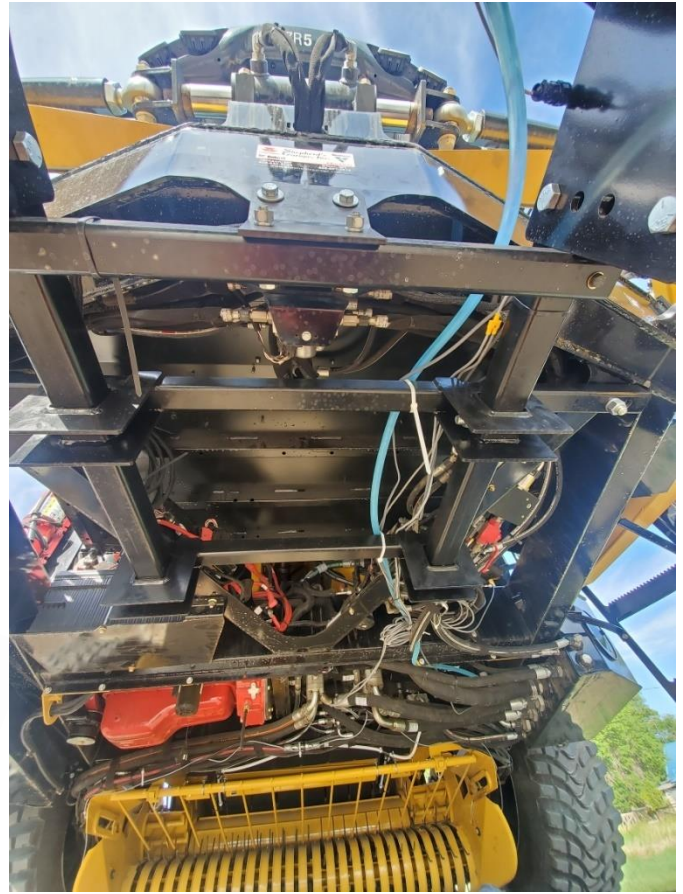
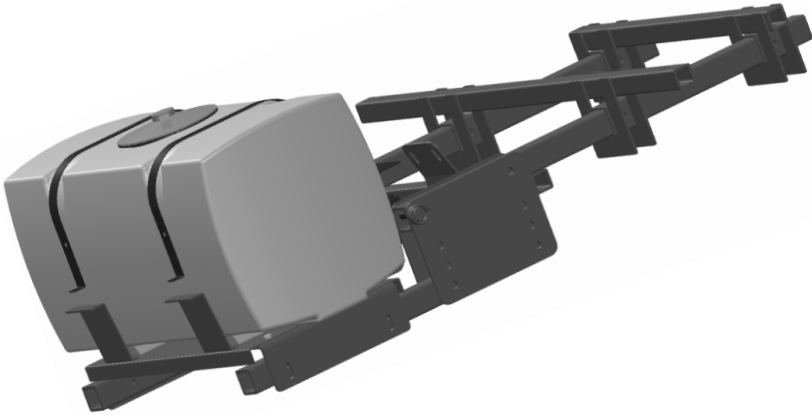
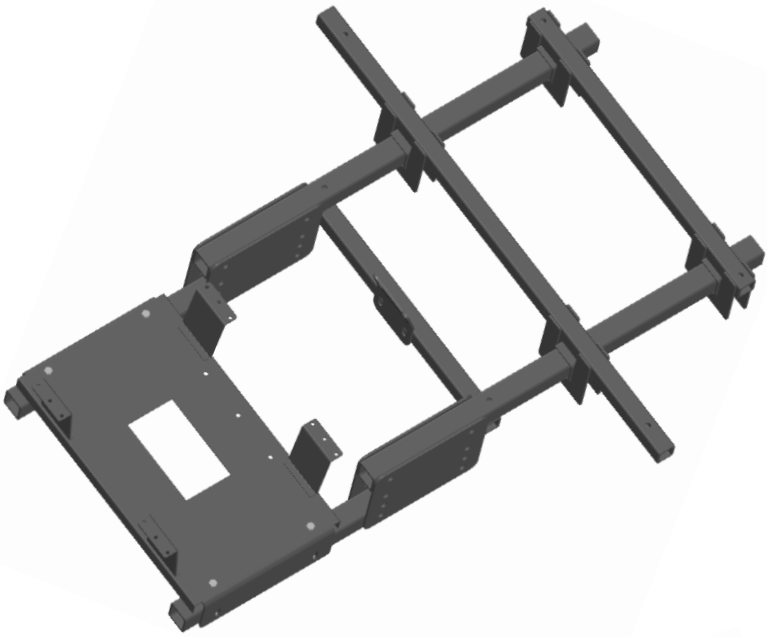
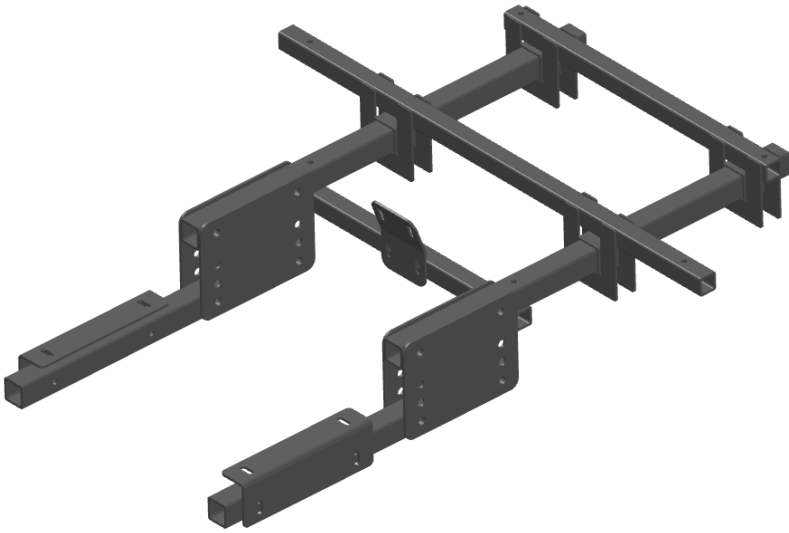

Mount Pump Plate Assembly

Locate parts bag 8. Using two 3/8" x 1/4" bolts, locks, washers, and nuts. Mount the U-shaped pump plate mount 001-4647 (right) onto the tank saddle in the mounting holes located between the strap brackets on back of saddle (figure 7).

Connect the pump plate mounting bracket (001-4648X), shown in figure 8, using two 3/8" x 1 1/4" bolts, nuts, locks, and flat washers to the mounting bracket. Install the pump plate as shown completed in figure 9.

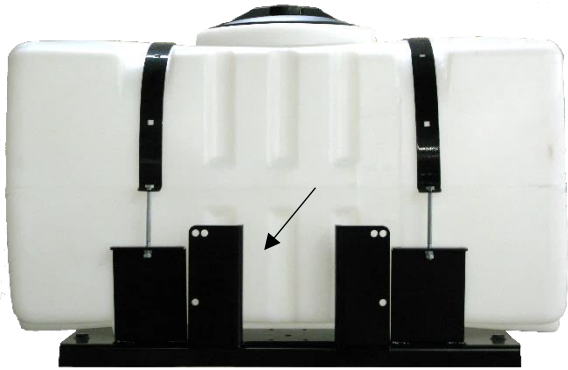

Figure 7



Figure 8

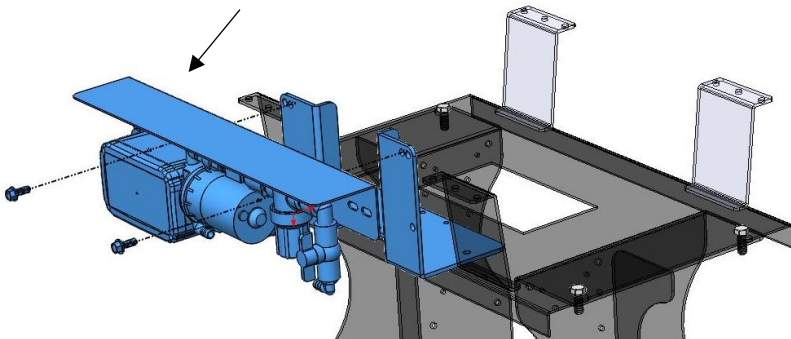

Figure 9

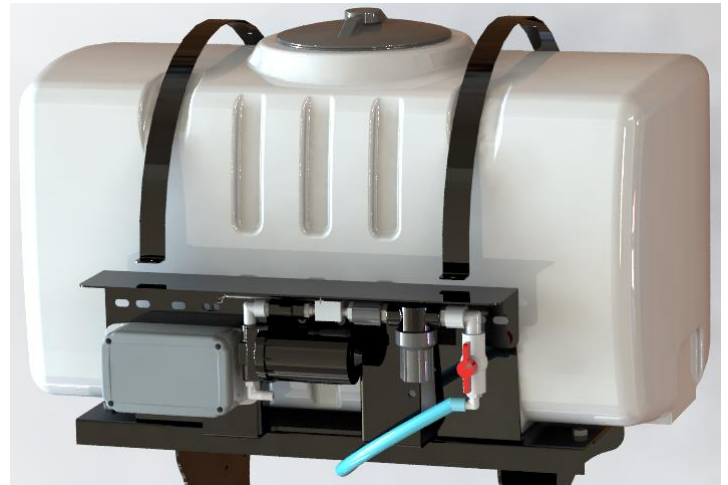
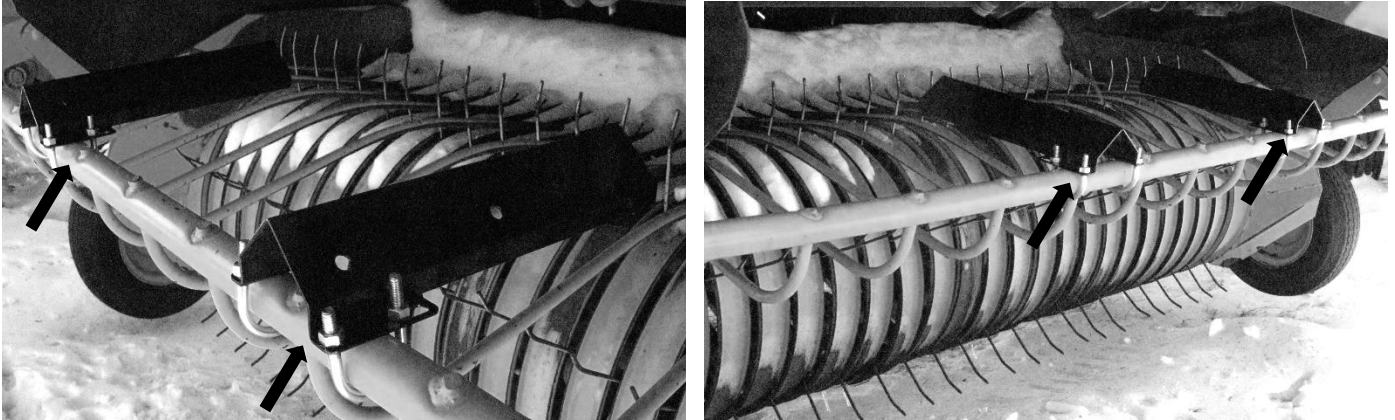

Figure 10

Placement of Spray Nozzle Assembly

The cross bar on the wind guard above the pick-up head provides a mounting point for the nozzle holders (001-4714J). Mount the nozzle holders on the wind guard, using the supplied U bolts (001-4714UBS). Measuring from the center of the baler, the nozzle holders will need to be 6" (15cm) apart on a 4' (1.2M) and 9" (23cm) apart on a 5' (1.5M). Do not fully tighten.

Position the nozzle holders so that the tips spray in a horizontal direction over the top of the baler's pickup. The tips should be located so that they will be between 14" and 18" (35 - 45 cm) from the normal path of hay. Make sure the nozzle holders do not interfere with the tying system. *It is recommended to test the system with water prior to field operation. This will ensure the fan pattern from the tips reaches the outside edges of the pickup while having a slight overlap in the center.



Installation of Plumbing

A. Intake

Locate parts bag 16. Use the 003-EL3412 on the bottom of the tank to route 1/2" line (002-9001) to the 003-A1212 or 003-EL1212 fitting used on the ball valve attached to the pump plate. Attach hose clamps (003-9003) on both of the fittings.

B. Discharge

Route the 1/2" hose from the pump output toward the front of the baler and connect to the solenoid assembly (SOL-3SP-A). Secure the solenoid assembly and hose along baler, positioning the solenoid as close to the spray tips as possible. Connect the 1/4" hose to the outgoing side of the solenoid to tip assembly.

C. Low, Standard and High Output Tips

Your baler comes with two sets of tips: a low set and a high set.

-Low set will cover outputs of 60 - 300 lbs/hr (27-300 L/hr).

-Standard set will cover outputs of 48- 448 lbs/hr (21-203 L/hr).

-High (optional) set will cover outputs of 80-800 lbs/hr (36L-363L).

Installation of Moisture Sensing Pads

*Most balers will have a moisture system already installed on the baler. If not, follow the instructions below. Note: If your baler does have a factory moisture system installed. You can use the factory moisture disc. However, you will need to disconnect the wires leading to both sensors and tape them up. You cannot have the balers moisture wires and Harvest Tec's moisture wires connected to the moisture disc at the same time.



1. If your baler is equipped with bale shaping pads, remove disc and use existing that will need to be drilled to 3/4" (19mm) to install new moisture sensing discs. If the discs are welded, the welds will need to ground off for disc removal.
2. If your baler is not equipped with bale shaping pads you will need to drill a hole in the chamber directly behind and above the starting roll (Figure 1).
3. The mounting hole will be 3/4" (19mm) in diameter. Use a plastic pad (006-4641F) and place it into the baler to use as a template. The bottom edge of the pad will be placed 1" (25mm) up from starting roll and 2" (51mm) from the back of the bale chamber. (Figure 1)

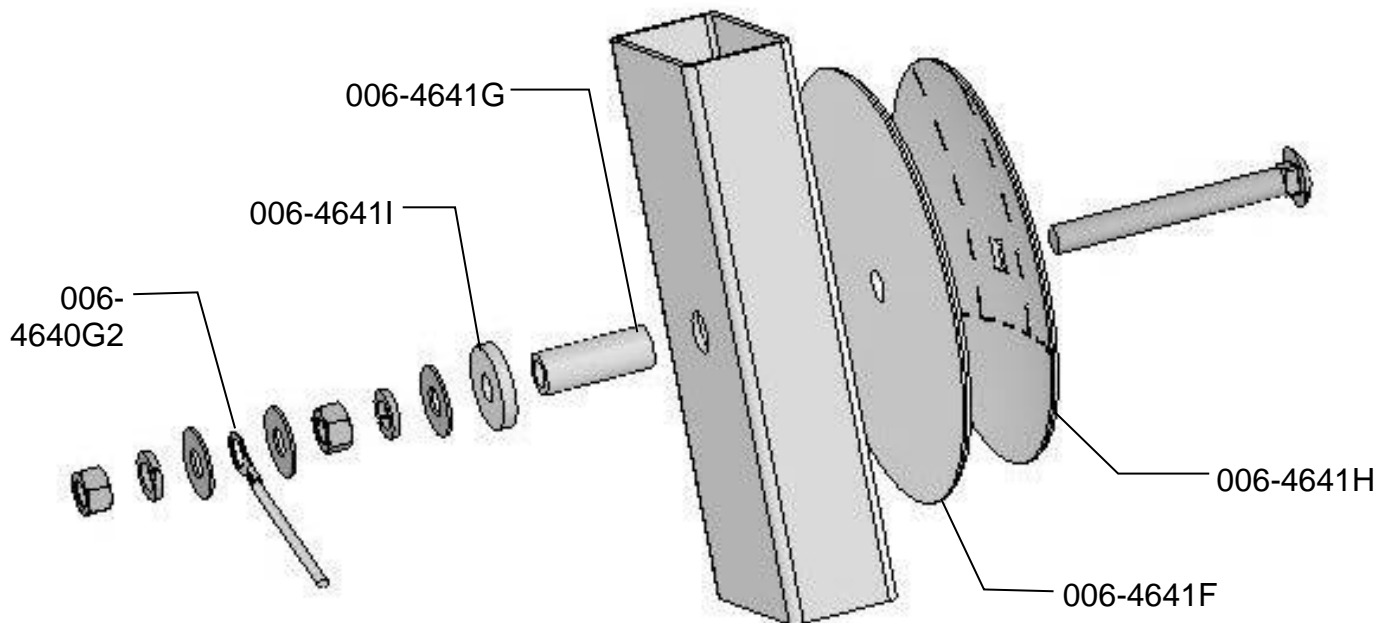

4. Depending on the baler the bolt may need to be trimmed for proper fit.
5. Tighten all of the hardware to 50 ft/lbs (68 N/m).
6. Make sure that the plastic pad is protecting all metal surfaces of the disc from touching baler.
7. Run the moisture wire harness (006-4640G2) from pump plate area to each disc and secure
8. Apply silicone over nuts and washers.

Installation of Bale Sensor

The bale rate timer sensor is used to determine when the baler door is open. With this information the system is able to change the tons/hour automatically (see Operating Instructions, Automatic Mode).

Locate the sensor (006-7400) and the sensor bracket (001-4648RB). On the right side of the baler find a location 1"– 6" down from the hinge to mount the bracket. Check for clearance with hydraulic cylinders before mounting the bracket. The bracket should be mounted to the front side of the hinge point, with the sensor aligned over the back door.

Mark and drill two 1/4" (7mm) holes and install the bracket using two 5/16" x1/4" self-tapping bolts.

Install the sensor into the bracket and leave 1/4" (7mm) of clearance between the end of the sensor and the door.

The harness will need to be routed towards the Processor. Secure with cable ties and take care to avoid pinch points. The harness extension (006-7400EXT) may need to be used.

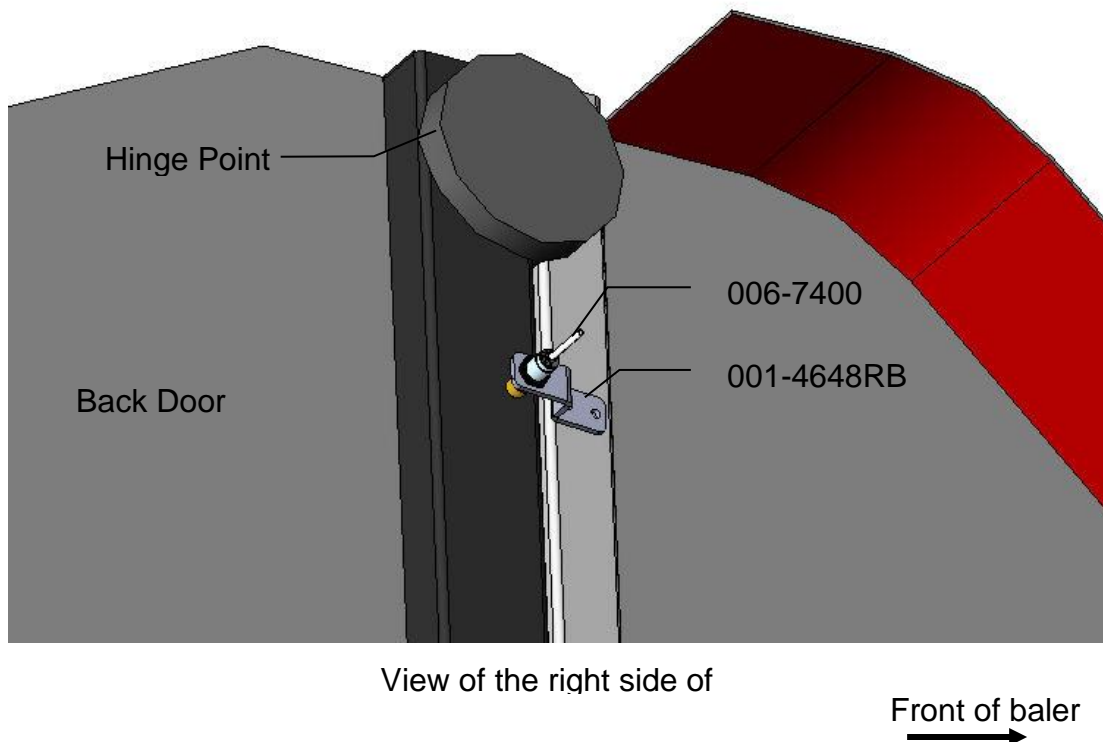

***Additional parts and harness extensions have been included to allow you to easily disconnect the baler unit from the power unit, use as needed.**

Installation of iPad Integration Control

Locate a safe location in the cab of the tractor to place the iPad Integration Control (030-6672C). Recommended location is securely fastened out of the operators way in a location that is close enough to reach with the iPad cord.

Connect the Power / Communication harness (006-6650TM(E)) to the bottom of the receiver.

To operate the applicator, plug the iPad cord into the communication port indicated by:

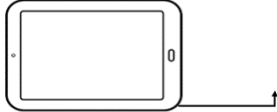

iPad Integration Control Light Signals

Green Slow Blink – Power supplied to the applicator system and the unit is going through its startup process. This will take approximately 25-35 seconds.

Green Double Blink – Indicating the iPad module recognizes the iPad but the app is not open or connected.

Green Solid Light – Module is connected to the app and is ready to operate.

*Recommended to use the USB cable included with the applicator kit (006-6672USBC)

Hay App version must be **at least 2.7.1 (or higher)** to operate with the iPad Integration Module (030-6672C)

*Made for Apple iPad badge

Use of the Made for Apple iPad badge means that an accessory has been designed to connect specifically to the Apple product(s) identified in the badge and has been certified by the developer to meet Apple performance standards. Apple is not responsible for the operation of this device or its compliance with safety and regulatory standards.

Please note that the use of this accessory with an Apple product may affect wireless performance.

Wiring Diagram

1. Connect the power harness (006-3650T) to the tractor battery (12 volt) using the red wire with fuse to the positive side and the black wire to the negative.



- a. **The power harness must be connected to the battery!** The unit will draw more amps than convenience outlets can handle. Any modifications of the power harness will void systems warranty. **CONTACT HARVEST TEC BEFORE MODIFICATIONS.**
- b. **This unit will not function on positive ground tractors.**
- c. **If the unit loses power while operating it will not keep track of accumulated pounds of product used.**

2. The power harness on the tractor (006-3650T) will run from the tractor battery to the hitch. The power harness on the baler (006-3650B1) will connect to the tractor power harness (006-3650T) at the hitch.
3. Connect the keyed power wire (006-5650K) to a keyed power source on the tractor. **The keyed power wire must connect to a keyed source or the unit will not power up correctly.**
4. Attached the iPad Integration Control (030-6672C) to the tractor power harness (006-3650T).
5. Attach the End of Bale (EOB) connection on the controller to the End of Bale Sensor (006-7400).
6. Attach the Solenoid (V1) (Delphi connector) connection on the controller to the wire from the solenoid (002-2203F). Note: If solenoid is connected to V2-DSM (not used) connection, solenoid will not work.
7. Attach the Flowmeter (FLOW) connection on the controller to the flowmeter (006-4729A).
 - a. Attach the spade connectors on the FLOW harness to the Pump (007-4120DE).

System wiring diagram

*Note: (E) indication is used for International Dealers

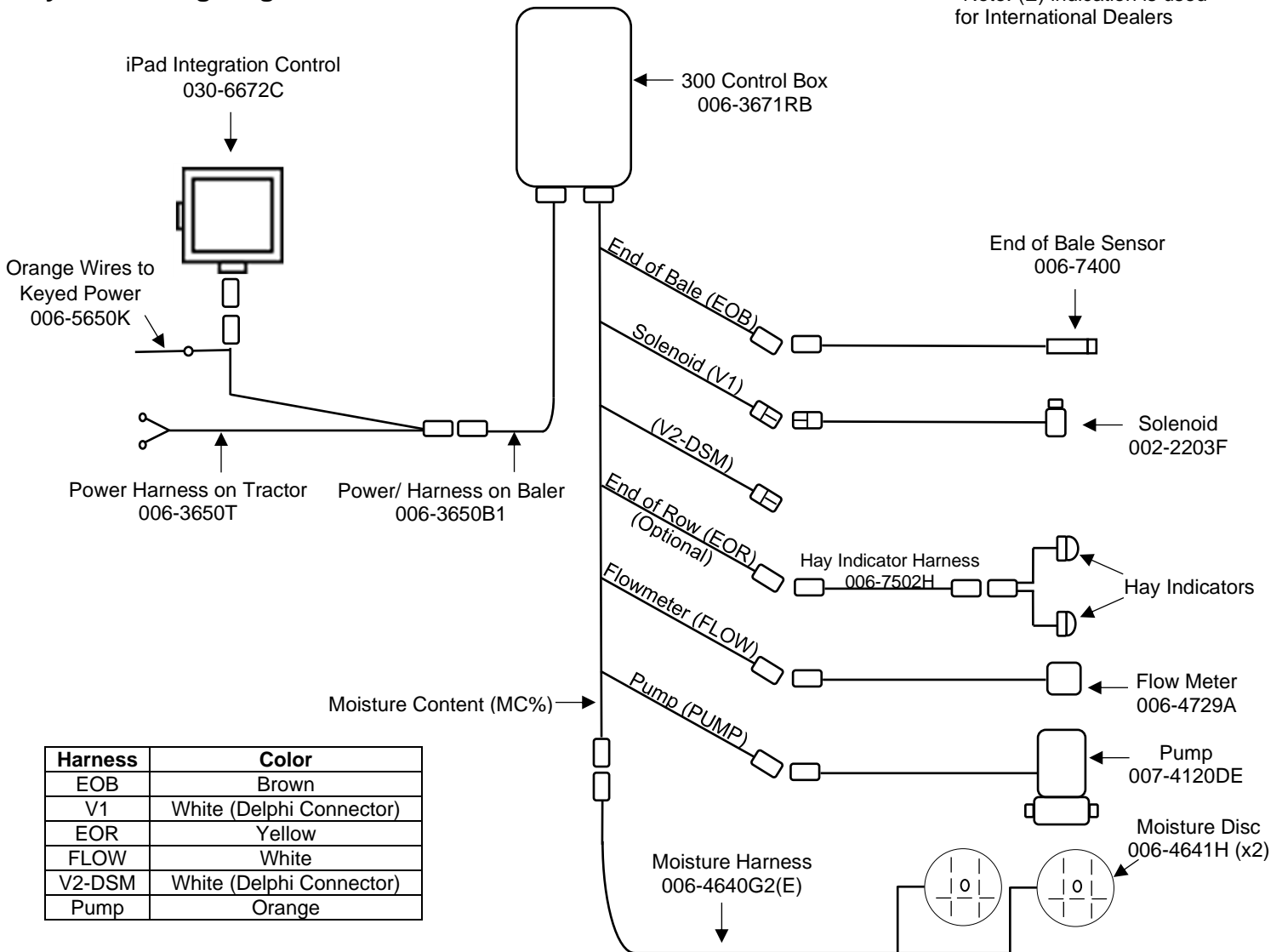

Harness	Color
EOB	Brown
V1	White (Delphi Connector)
EOR	Yellow
FLOW	White
V2-DSM	White (Delphi Connector)
Pump	Orange

Pin Outs

Power Harness 006-3650T at Tractor Hitch

Pin 1	Red	+12V Power to BLE
Pin 2	Red	+12V Power to THS
Pin 3	Orange	Keyed Power
Pin 4	Not Used	
Pin 5	Green	HT Can Low
Pin 6	Yellow	HT Can Hi
Pin 7	Not Used	
Pin 8	Black	Ground from BLE
Pin 9	Black	Ground from THS
Pin 10	Not Used	



Power Harness 006-3650B1 at Baler Hitch

Pin 1	Red	+12V Power to BLE
Pin 2	Red	+12V Power to THS
Pin 3	Orange	Keyed Power
Pin 4	Not Used	
Pin 5	Green	HT Can Low
Pin 6	Yellow	HT Can Hi
Pin 7	Not Used	
Pin 8	Black	Ground from BLE
Pin 9	Black	Ground from THS
Pin 10	Not Used	



iPad Integration Control / BLE Receiver on Harness 006-3650T

Pin 1	Red	+12V Power for BLE
Pin 2	Black	Ground for BLE
Pin 3	Yellow	HT Can Low
Pin 4	Not Used	
Pin 5	Green	HT Can Hi
Pin 6	Not Used	
Pin 7	Not Used	

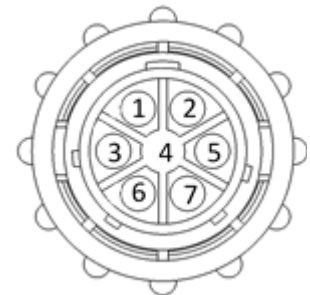

End of Bale Sensor at 300 Controller Harness

Pin 1	Brown	Sensor Power
Pin 2	Blue	Sensor Ground
Pin 3	N/A	
Pin 4	Black	Signal from Sensor

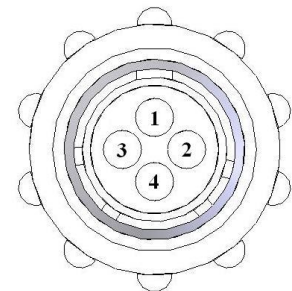

Flow Meter at 300 Controller Harness

Pin 1	White	+5-12V Power
Pin 2	Brown	Ground
Pin 3	Green	Signal
Pin 4	Not Used	

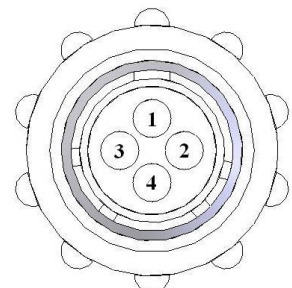

Pin Outs (continued)

End of Row Sensor at 300 Controller Harness

Pin 1	Red/White	+12V Power
Pin 2	Black/White	Ground
Pin 3	Yellow	Signal
Pin 4	N/A	

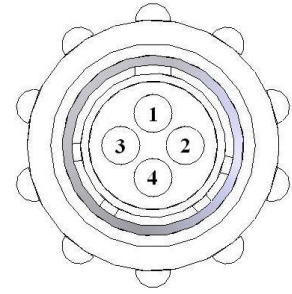

Moisture Sensor connection at 300 Controller Harness

Pin 1	Not Used	
Pin 2	Not Used	
Pin 3	Not Used	
Pin 4	Not Used	
Pin 5	Not Used	
Pin 6	Not Used	
Pin 7	Not Used	
Pin 8	Blue	Signal for Sensor 1
Pin 9	Blue	Signal for Sensor 2

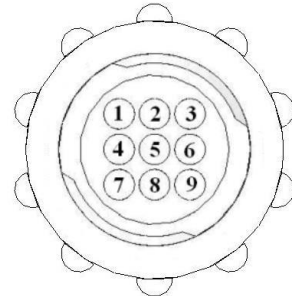

Pump connection at 300 Controller Harness

Pin 1	Red	Power to Pump
Pin 2	Black	Ground to Pump

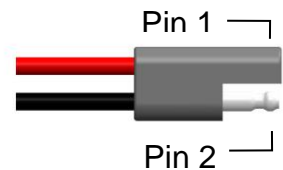

Solenoid Connection at 300 Controller Harness

Pin A	Black	Solenoid Pause
Pin B	White	Solenoid Ground

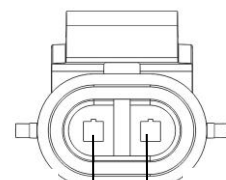
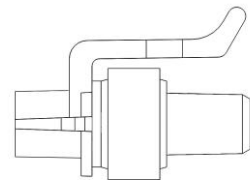
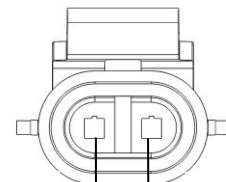
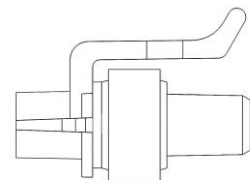

Pin A Pin B

V2-DSM Connection at 300 Controller Harness

Pin A	Black	Solenoid Pause
Pin B	White	Solenoid Ground

Model 335Z Base Kit

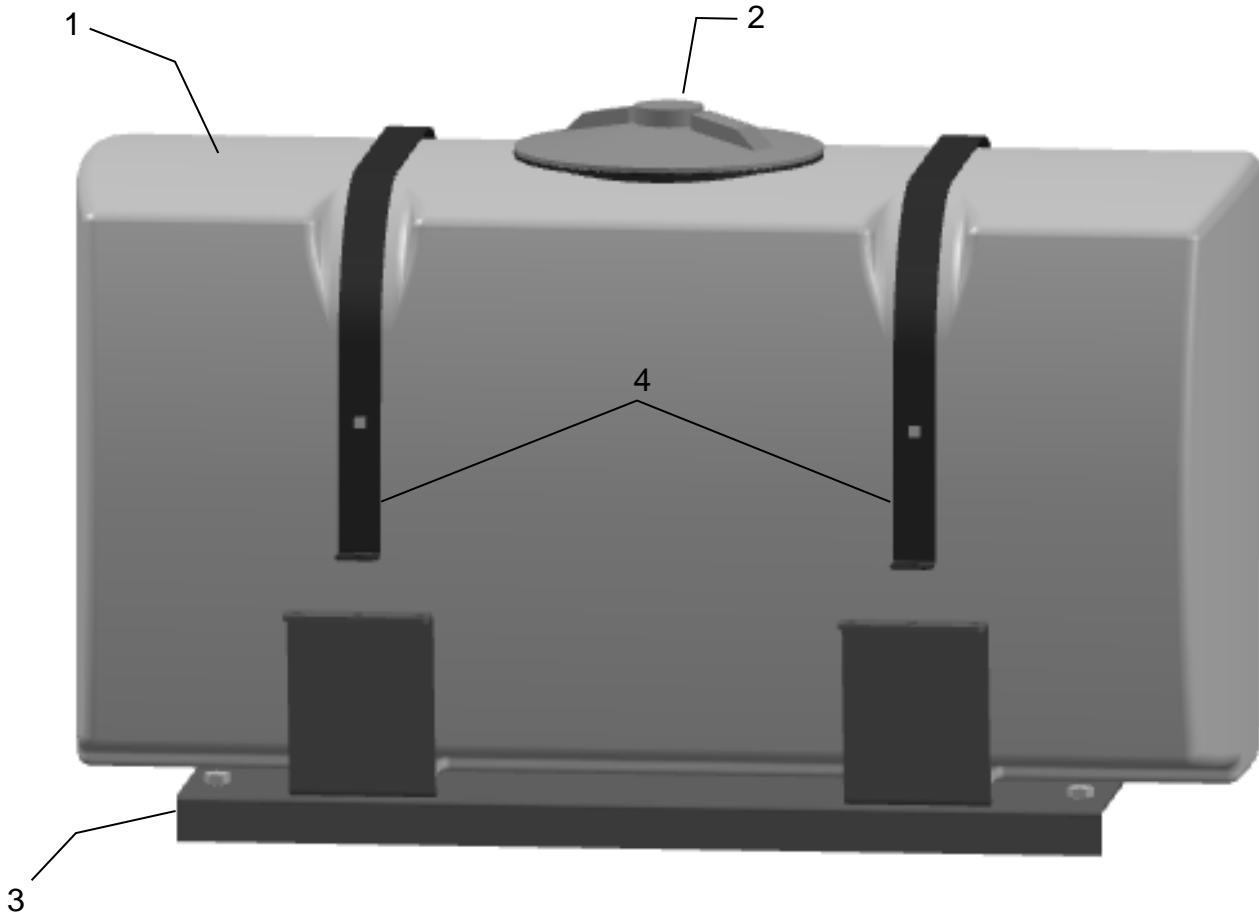

<u>Ref</u>	<u>Description</u>	<u>Part #</u>	<u>Qty</u>	<u>Ref</u>	<u>Description</u>	<u>Part #</u>	<u>Qty</u>
1	50 Gallon Tank	005-9203SQ	1	7	Side Rail Plate	001-4703ZR-E	4
2	Tank Cap, Gasket, & Breather	P05-9022HBG	1	8	Front Mount Support	001-4703ZR-D2	1
3	Tank Saddle	001-4703X	1	9	Front Mount Crossmember	001-4703ZR-D1	1
4	Tank Strap	001-4402	2	10	Long Side Rail	001-4703ZR-C	2
5	Tank Saddle Support	001-4703ZE-G	2	11	Mid Mount	001-4703ZR-B	1
6	Short Side Rail	001-4703ZR-F	2	12	Rear Mount	001-4703ZR-A	1
				NP	Hex Plug	003-F34	1
					Complete Kit	030-0445Z-TK	

Model 335Z Base Kit (continued)

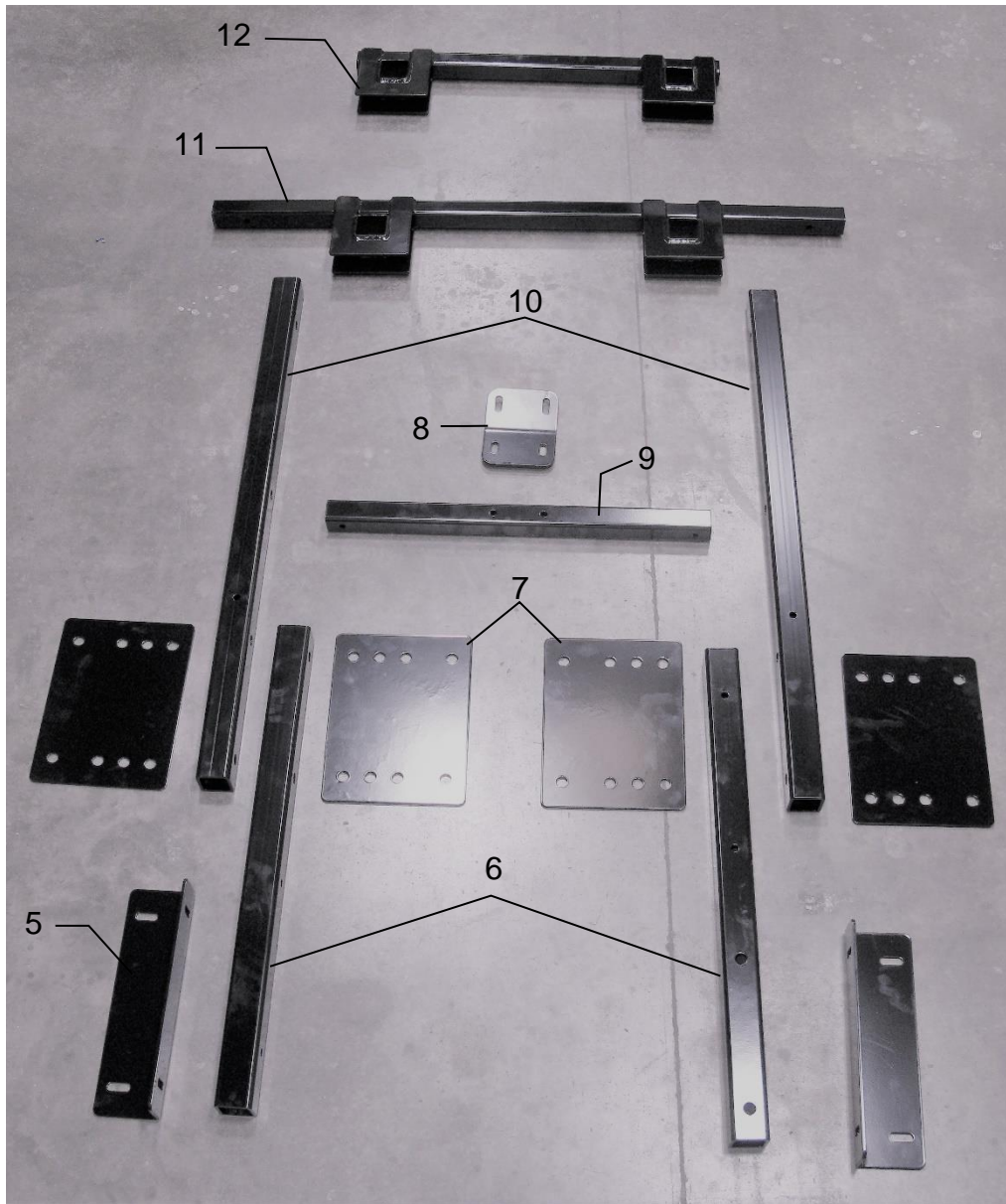

<u>Ref</u>	<u>Description</u>	<u>Part #</u>	<u>Qty</u>	<u>Ref</u>	<u>Description</u>	<u>Part #</u>	<u>Qty</u>
1	50 Gallon Tank	005-9203SQ	1	7	Side Rail Plate	001-4703ZR-E	4
2	Tank Cap, Gasket, & Breather	P05-9022HBG	1	8	Front Mount Support	001-4703ZR-D2	1
3	Tank Saddle	001-4703X	1	9	Front Mount Crossmember	001-4703ZR-D1	1
4	Tank Strap	001-4402	2	10	Long Side Rail	001-4703ZR-C	2
5	Tank Saddle Support	001-4703ZE-G	2	11	Mid Mount	001-4703ZR-B	1
6	Short Side Rail	001-4703ZR-F	2	12	Rear Mount	001-4703ZR-A	1
				NP	Hex Plug	003-F34	1
					Complete Kit	030-0445Z-TK	

Parts Breakdown for Pump Assembly

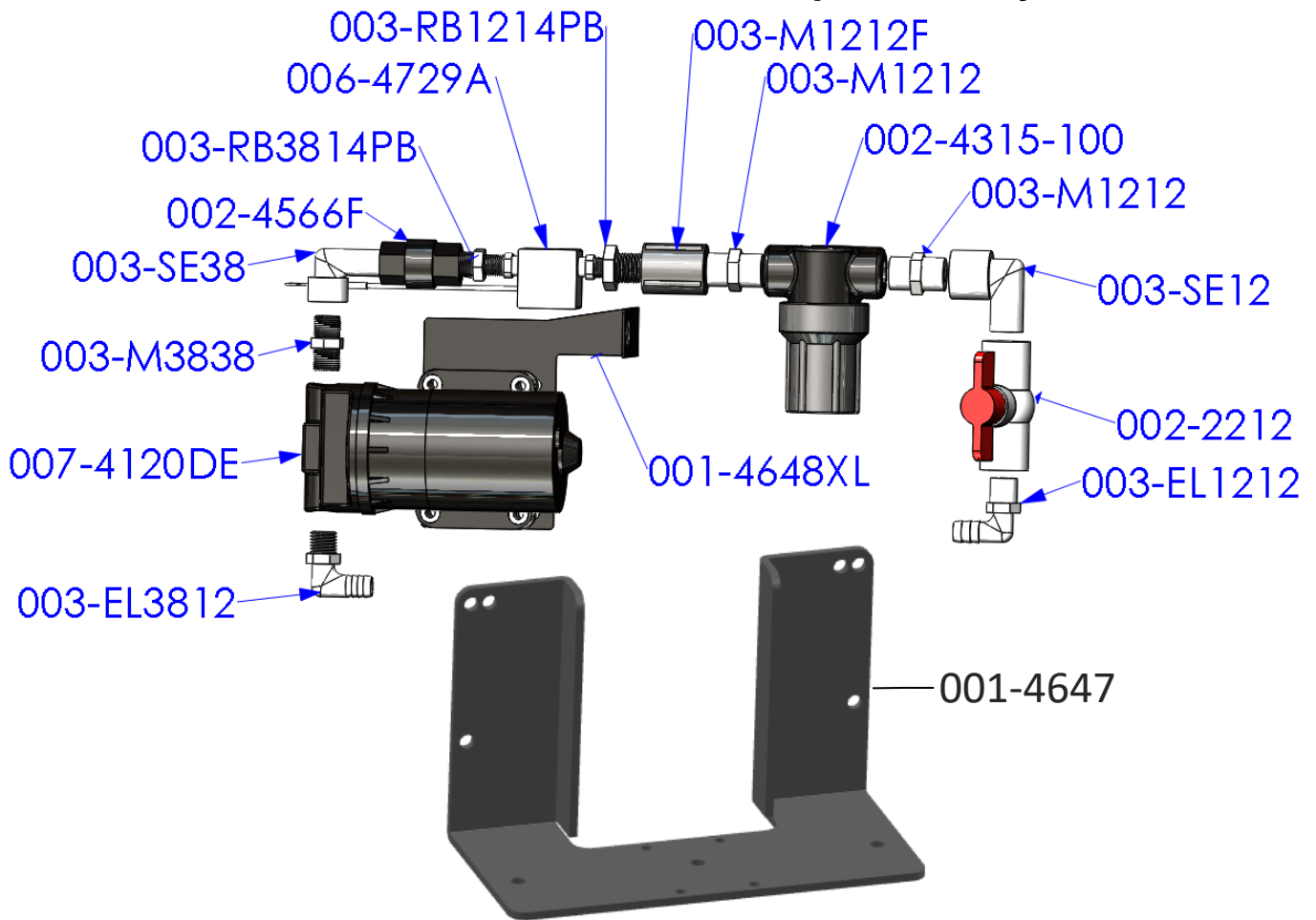

<u>Part#</u>	<u>Description</u>	<u>Qty</u>	<u>Part#</u>	<u>Description</u>	<u>Qty</u>
003-EL3812	3/8" MPT X 1/2" HB Elbow	1	003-M1212	1/2" Union	2
007-4120DE	300 Series Pump	1	002-4315-100	1/2" Line Strainer-100 Mesh	1
003-M3838	3/8" x 3/8" Union	1	003-SE12	1/2" Street Elbow	1
003-SE38	3/8" Street Elbow	1	002-2212	1/2" Ball Valve	1
002-4566F	3/8" Check Valve	1	003-EL1212	1/2" MPT x 1/2" HB	1
003-RB3814PB	RB 3/8" x 1/4" Reducer	1	001-4648XL	300 Pump Support	1
006-4729A	Flow Meter – Block Style	1	001-4648X	Pump Plate Mount	1
003-RB1214PB	RB 1/2" x 1/4" Reducer	1	003-A1212	Not Pictured	
003-M1212F	1/2" Coupler	1	003-A3812	Not Pictured	

Pump Assembly PMP-3636P (001-4647 Not Included)

Completed Assembly

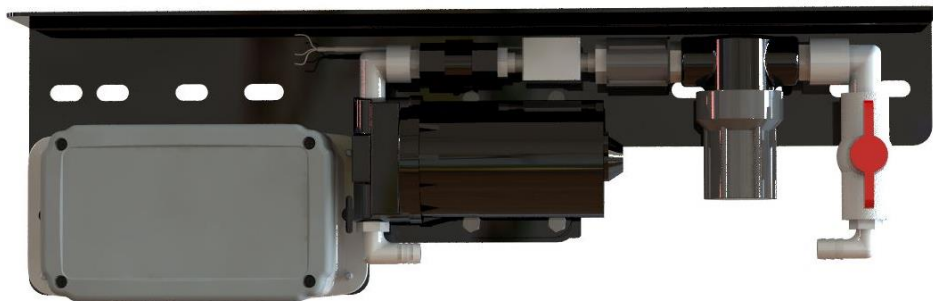

*Note: Due to alternative baler designs, elbow 003-EL3812 can be replaced by straight fitting 003-A3812. As well as elbow 003-EL1212 can be replaced by straight fitting 003-A1212. Both straight fittings are included.

300 Solenoid Packages

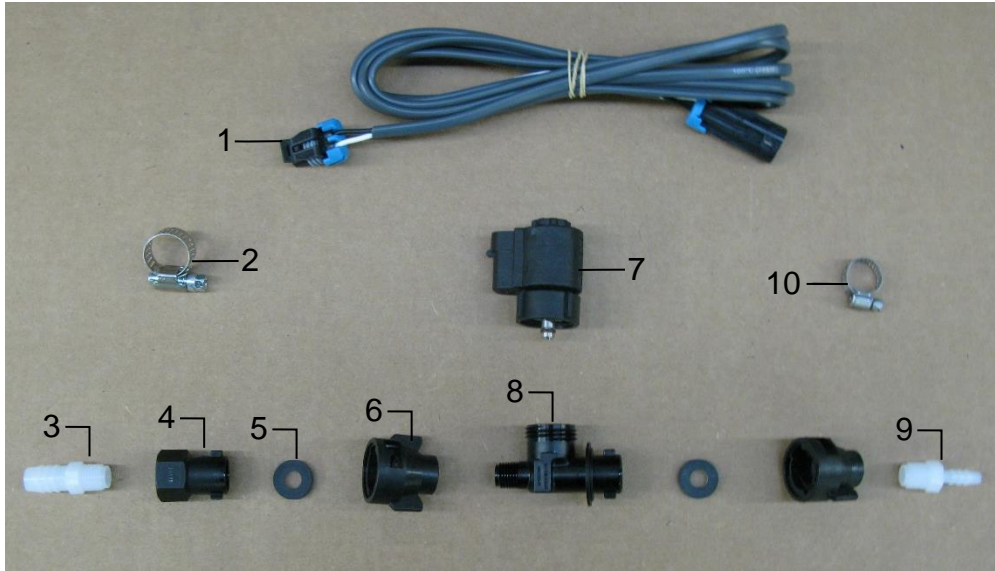

Solenoid Package A

<u>Ref</u>	<u>Description</u>	<u>Part #</u>	<u>Qty</u>	<u>Ref</u>	<u>Description</u>	<u>Part #</u>	<u>Qty</u>
1	Solenoid Harness (5')	006-3650-S2	1	6	1/4" Female Disconnect	004-1207H	2
2	#6 Hose Clamp	003-9003	1	7	Solenoid	002-2203F	1
3	1/4" x 1/2" Straight Fitting	003-A1412	1	8	Solenoid Valve Body	004-1207VF	1
4	1/4" Female Connector	004-1207G	1	9	1/4" x 1/4" Straight Fitting	003-A1414	1
5	Rubber Washer	004-1207W	2	10	Mini Hose Clamp	003-9002	1
					Complete Assembly	SOL-3SP-A	

Moisture Sensors

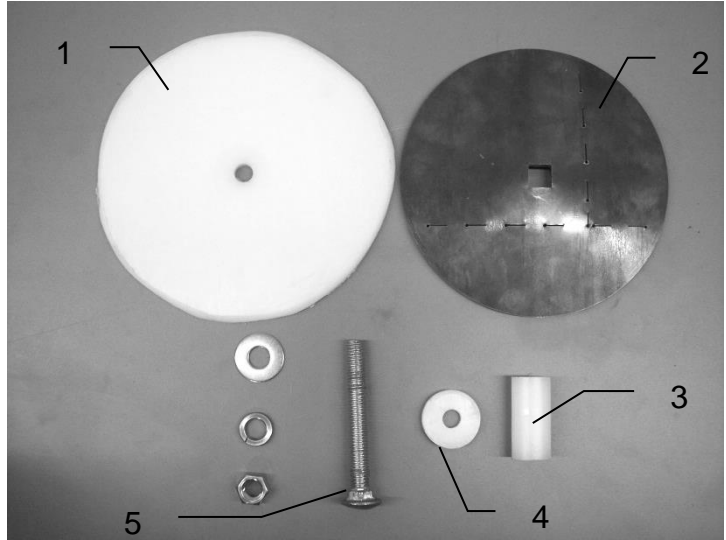

<u>Ref</u>	<u>Description</u>	<u>Part #</u>	<u>Qty</u>	<u>Ref</u>	<u>Description</u>	<u>Part #</u>	<u>Qty</u>
1	Plastic Pad	006-4641F	2	4	Plastic Isolator	006-4641I	2
2	Moisture Disc	006-4641H	2	5	1/2X4 1/2" Carriage Bolt	Hardware	2
3	Plastic Bushing	006-4641G	2	6	Moisture Cable	006-4640G2	1
					Moisture Pad Assembly (Ref 1-5)	030-4643	2
					Complete Assembly (Ref 1-6)	MSH-RB-A	

Control Box and Wiring Harnesses

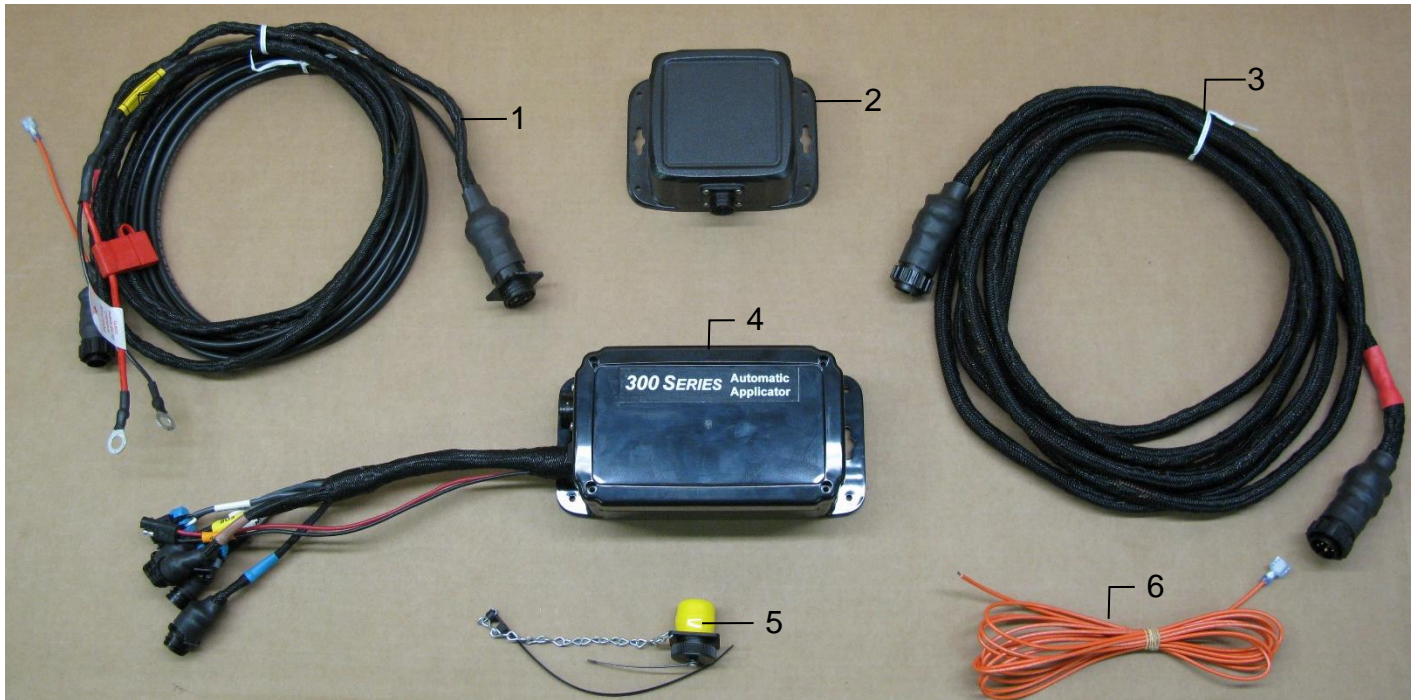

<u>Ref</u>	<u>Description</u>	<u>Part #</u>	<u>Qty</u>
1	Tractor Power Harness	006-3650T	1
2	iPad Integration Control	030-6672C	1
3	Baler Power Harness (20')	006-3650B1	1
4	Control Box	006-3671RB	1
5	Dust Plug Kit	006-5651Plug	1
6	Key Switch Harness	006-5650K	1
NP	USB Cable	006-6672USBC	1
	Complete Assembly	030-363CPA	

End of Bale Sensor Kit A

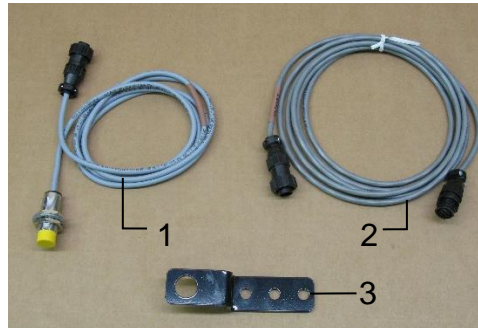

<u>Ref</u>	<u>Description</u>	<u>Part #</u>	<u>Qty</u>
1	End of Bale Sensor	006-7400	1
2	EOB Extension	006-7400EXT	1
3	End of Bale Bracket	001-4648RB	1
	Complete Assembly	EOB-RB-A	

Parts Bag Packages

PBA-1

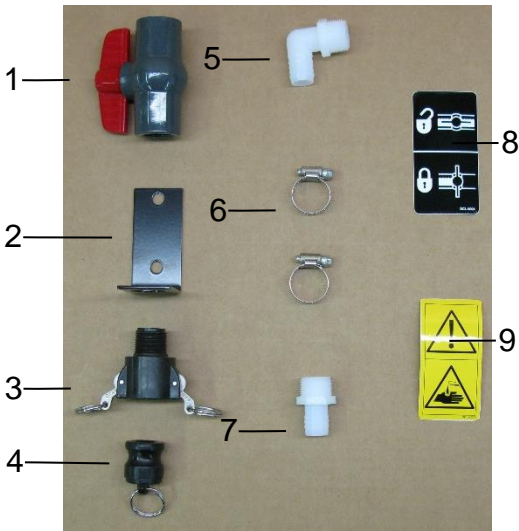

<u>Ref</u>	<u>Description</u>	<u>Part #</u>	<u>Qty</u>
1	3/4" Ball Valve	002-2200	1
2	Valve Holder	001-6702H	1
3	Female Coupler	002-2204A	1
4	Male Shut-Off Plug	002-2205G	1
5	3/4" x 3/4" Elbow	003-EL3434	1
6	#10 Hose Clamp	003-9004	2
7	3/4" x 3/4" Straight Fitting	003-A3434	1
8	Valve Decal	DCL-8004	1
9	Chemical Hazard Decal	DCL-8001	1
Complete Drain Fill Kit		030-0493DFK	

PBP-16

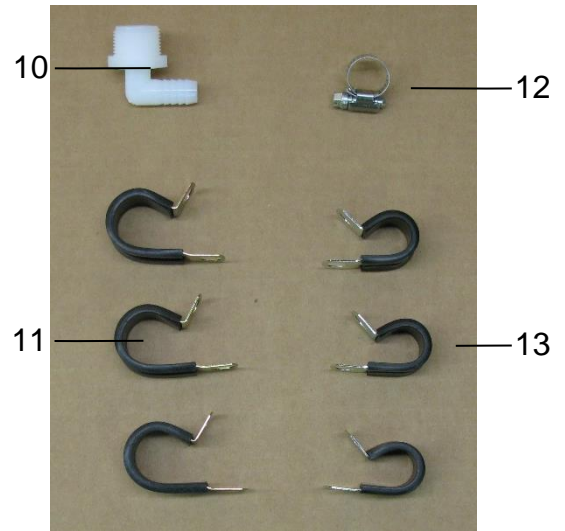

<u>Ref</u>	<u>Description</u>	<u>Part #</u>	<u>Qty</u>
10	3/4" x 1/2" Elbow	003-EL3412	1
11	3/4" Jiffy Clip	008-9010	3
12	#6 Hose Clamp	003-9003	1
13	Small Jiffy Clip	008-9009	3

Hoses

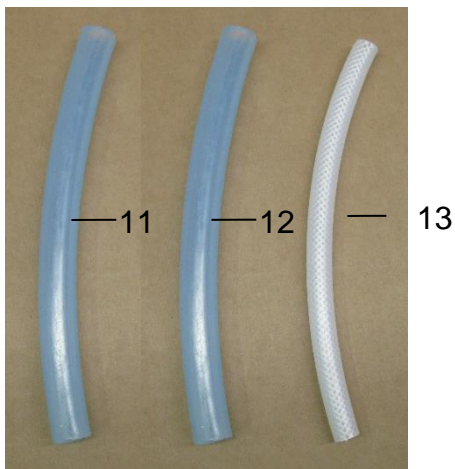

<u>Ref</u>	<u>Description</u>	<u>Part #</u>	<u>Qty</u>
11	1/2" Hose (Tank to Solenoid)	002-9001	15ft
12	3/4" Hose (Drain/Fill Line)	002-9002	6ft
13	1/4" Hose (Solenoid to Tips)	002-9016	6ft

335Z Spray Shield



<u>Ref</u>	<u>Description</u>	<u>Part #</u>	<u>Qty</u>	<u>Ref</u>	<u>Description</u>	<u>Part #</u>	<u>Qty</u>
1	U bolt	001-4714UBS	4	10	Tip Strainer	004-1203-100	2
2	Hose clamp	003-9002	2	11	Tip – White	004-XR11008VS	2
3	1/4" x 1/4" Fitting	003-A1414	5	12	Tip – Red	004-XR11004VS	2
4	1/4" Sq Tee	003-TT14SQ	1	13	Nozzle Body	004-4722	2
5	1/4" St Elbow	003-SE14F	1	14	Nozzle Cap	004-4723	2
6	Oetiker Clamp	003-9008	4	NP	477 Jiffy Clip	008-9014	2
7	Nozzle Holder	001-4714J	2				
8	Hose	002-9016	3ft		Shield Only (Ref 1-14)	030-4714J-SO	
9	1/4" x 1/4" Fitting	003-A1414F	2				

* Tip color subject to change

Optional iPad Mini Mounting Kit (030-2014MK)

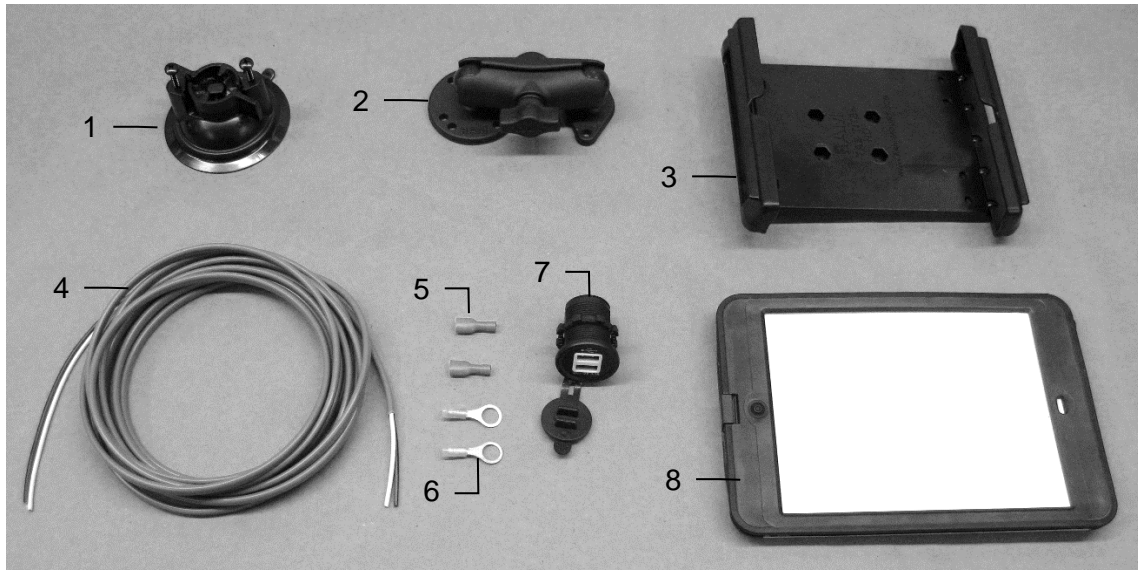

<u>Ref</u>	<u>Description</u>	<u>Part #</u>	<u>Qty</u>
1	Suction cup mount	001-2012SCM	1
2	Ram mount	001-2012H	1
3	iPad Mini® spring load cradle (Mini 4)	001-2012SLC	1
4	16 gauge power wire	006-4723P	1
5	Female spade connector	Hardware	2
6	Eye loop connector	Hardware	2
7	iPad Mini Charger 12V	001-2012P	1
8	iPad Mini 4 case	001-2012C4	1
NP	4 amp fuse	Hardware	1
	Mounting Kit Assembly	030-2014MK (Includes All Parts)	

Installation Instructions

1. Identify 12V power source for wires to connect.
 - a. Eye loops included if wiring directly to the battery is desired.
 - b. Test for key power source if preferred to have power to the USB shut off with the key.
2. Once power source is identified, cut wires to desired length.
3. Crimp the two supplied quick connectors onto each the white and black wire.
4. Remove the round locking plastic nut from USB plug before connecting the wires. Black (+) White (-).
5. The wires will then be hooked to the designated terminals on the bottom of the USB plug
6. Drill a 1 1/8" hole in the preferred mounting location. Be sure to clean any sharp edges after drilling.
7. Feed the wires through the mounting hole.
8. If using the round plastic nut to secure plug in place, slide the nut back over the wiring before connecting the wires to powered source.
9. Connect the wires to the identified power source if easier to do so before tightening the plug into place.
10. Tighten plug using either the round plastic nut or mounting plate and two screws, both options supplied.
11. Once connected, hook a USB charging cord into the plug and connect a mobile device/tablet to ensure the plug is operating as you wish (key power working properly if necessary).

NOTE: This plug is not designed to charge two iPads. System damage could occur if this is attempted. System will charge a mobile phone and iPad simultaneously without problem.

*iPad mini is a trademark of Apple Inc., registered in the U.S. and other countries.

Optional iPad Display Kit (030-4670DK)

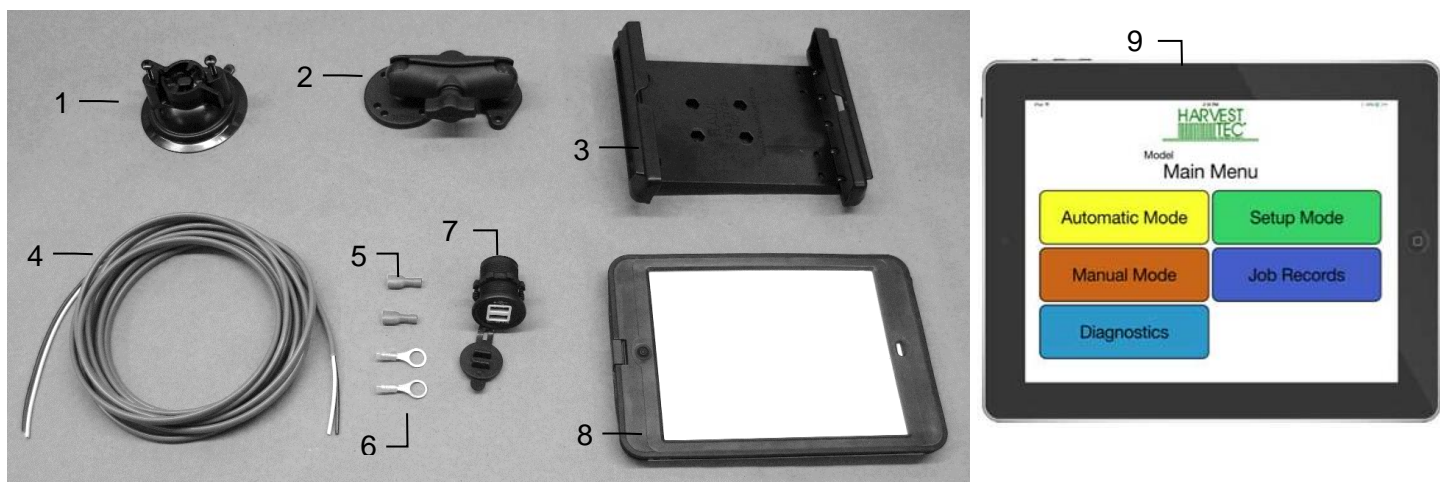

Ref	Description	Part #	Qty	Ref	Description	Part #	Qty
1	Suction cup mount	001-2012SCM	1	7	iPad Mini Charger 12V	001-2012P	1
2	Ram mount	001-2012H	1	8	iPad Mini 4 case	001-2012C4	1
3	iPad Mini spring load cradle (Mini 4)	001-2012SLC	1	9	iPad Mini 4	006-4670IP	1
4	16 gauge power wire	006-4723P	1	NP	4 amp fuse	Hardware	1
5	Female spade connector	Hardware	2				
6	Eye loop connector	Hardware	2				
					Mounting Kit Assembly	030-4670DK (Includes All Parts)	

Installation Instructions

1. Identify 12V power source for wires to connect.
2. Eye loops included if wiring directly to the battery is desired.
3. Test for key power source if preferred to have power to the USB shut off with the key.
4. Once power source is identified, cut wires to desired length.
5. Crimp the two supplied quick connectors onto the white and black wire.
6. Remove the round locking plastic nut from USB plug before connecting the wires. Black (+) White (-).
7. The wires will then be hooked to the designated terminals on the bottom of the USB plug
8. Drill a 1 1/8" hole in the preferred mounting location. Be sure to clean any sharp edges after drilling.
9. Feed the wires through the mounting hole.
10. If using the round plastic nut to secure plug in place, slide the nut back over the wiring before connecting the wires to powered source.
11. Connect the wires to the identified power source if easier to do so before tightening the plug into place.
12. Tighten plug using either the round plastic nut or mounting plate and two screws, both options supplied.
13. Once connected, hook a USB charging cord into the plug and connect a mobile device/tablet to ensure the plug is operating as you wish (key power working properly if necessary).

NOTE: This plug is not designed to charge two iPads. System damage could occur if this is attempted. System will charge a mobile phone and iPad simultaneously without problem.

*iPad mini is a trademark of Apple Inc., registered in the U.S. and other countries.

Harvest Tec Inc. Warranty and Liability Agreement

Harvest Tec, Inc. will repair or replace components that are found to be defective within 12 months from the date of manufacture. Under no circumstances does this warranty cover any components which in the opinion of Harvest Tec, Inc. have been subjected to negligent use, misuse, alteration, accident, or if repairs have been made with parts other than those manufactured and obtainable from Harvest Tec, Inc.

Our obligation under this warranty is limited to repairing or replacing free of charge to the original purchaser any part that in our judgment shows evidence of defective or improper workmanship, provided the part is returned to Harvest Tec, Inc. within 30 days of the failure. If it is determined that a non-Harvest Tec branded hay preservative has been used inside the Harvest Tec applicator system where the failure occurred, then Harvest Tec reserves the right to deny the warranty request at their discretion. Parts must be returned through the selling dealer and distributor, transportation charges prepaid.

This warranty shall not be interpreted to render Harvest Tec, Inc. liable for injury or damages of any kind, direct, consequential, or contingent, to persons or property. Furthermore, this warranty does not extend to loss of crop, losses caused by delays or any expense prospective profits or for any other reason. Harvest Tec, Inc. shall not be liable for any recovery greater in amount than the cost or repair of defects in workmanship.

There are no warranties, either expressed or implied, of merchantability or fitness for particular purpose intended or fitness for any other reason.

This warranty cannot guarantee that existing conditions beyond the control of Harvest Tec, Inc. will not affect our ability to obtain materials or manufacture necessary replacement parts.

Harvest Tec, Inc. reserves the right to make design changes, improve design, or change specifications, at any time without any contingent obligation to purchasers of machines and parts previously sold.

Revised 4/17

HARVEST TEC, INC.
P.O. BOX 63
2821 HARVEY STREET
HUDSON, WI 54016 USA
PHONE: 715-386-9100
FAX: 715-381-1792
Email: info@harvesttec.com