

Wiring Diagram

- A. Locate the tractor power/communication harness (006-6650TM(E)).
- B. Connect the red power wire with the 50 amp fuse to the positive side of the battery (12 volt).
 - a. **The power harness must be connected to the battery!** The unit will draw more amps than convenience outlets can handle.
 - b. **This unit will not function on positive ground tractors.**
 - c. **If the unit loses power while operating it will not keep track of accumulated pounds of product used and bale records.**
- C. Connect the black ground wire to frame of tractor or negative side of battery (12 volt).
- D. Connect the iPad Integration Control (030-6672C) to the Communication Harness (006-6650TM(E)).
- E. Connect the key power orange wire to a keyed power source.

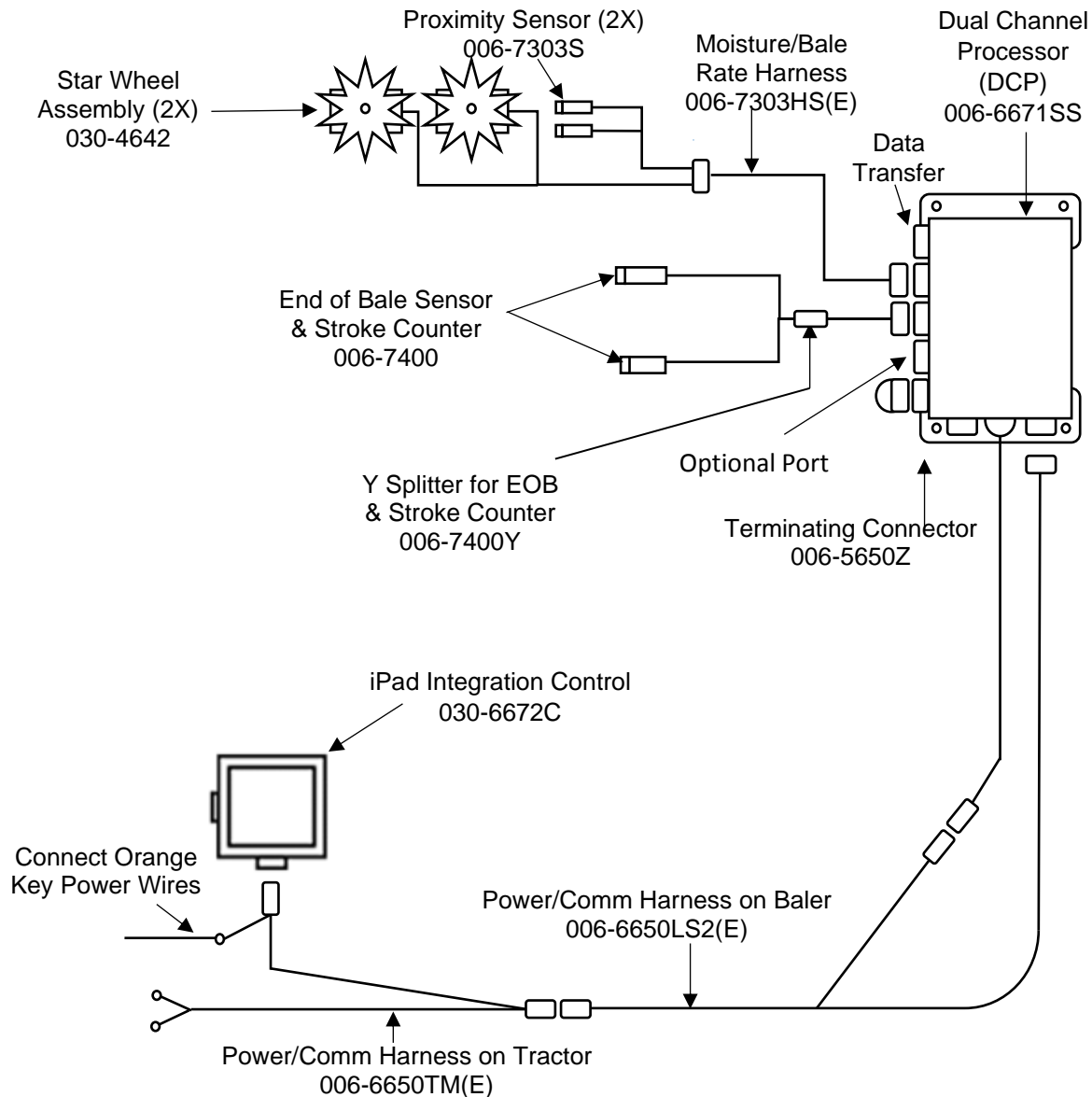

*Note: (E) indication is used for International Dealers