

Wiring Diagram

1. The **Baler Power/Communication Harness** (006-6650LS2(E)) will attach to the open port of the **Tractor Harness** (006-6650TM(E)) and run back to the **Dual Channel Processor** (006-6671LS). Connect the large plug of the Baler Power/Communication Harness (006-6650LS) to the bottom (shorter side) of the DCP.
2. Install green terminator (006-5650Z) to the port labeled **Modular Port** on the Pump Controller (006-5672).
3. Attach moisture and bale rate harness 006-7303H(E) (Claas & Krone kits 006-7303HX(E)) as well as the end of bale harness (006-7400) to the DCP (006-6671LS).
4. Attach the Pump Control Harness (006-5650FM(E)) between the Pump Controller (006-5672) and the DCP (006-6671LS).
5. Connect the orange wires and attach the plug to the tractor's ISOBUS port.
6. If using the optional ISOBUS connector (006-6670A) connect the end to the Communication Harness (006-6650TM(E)) in place of the iPad Integration Control (030-6672C) shown below.
7. Connect the orange keyed power wires (006-5650K) and attach the plug to the tractor's ISOBUS port.

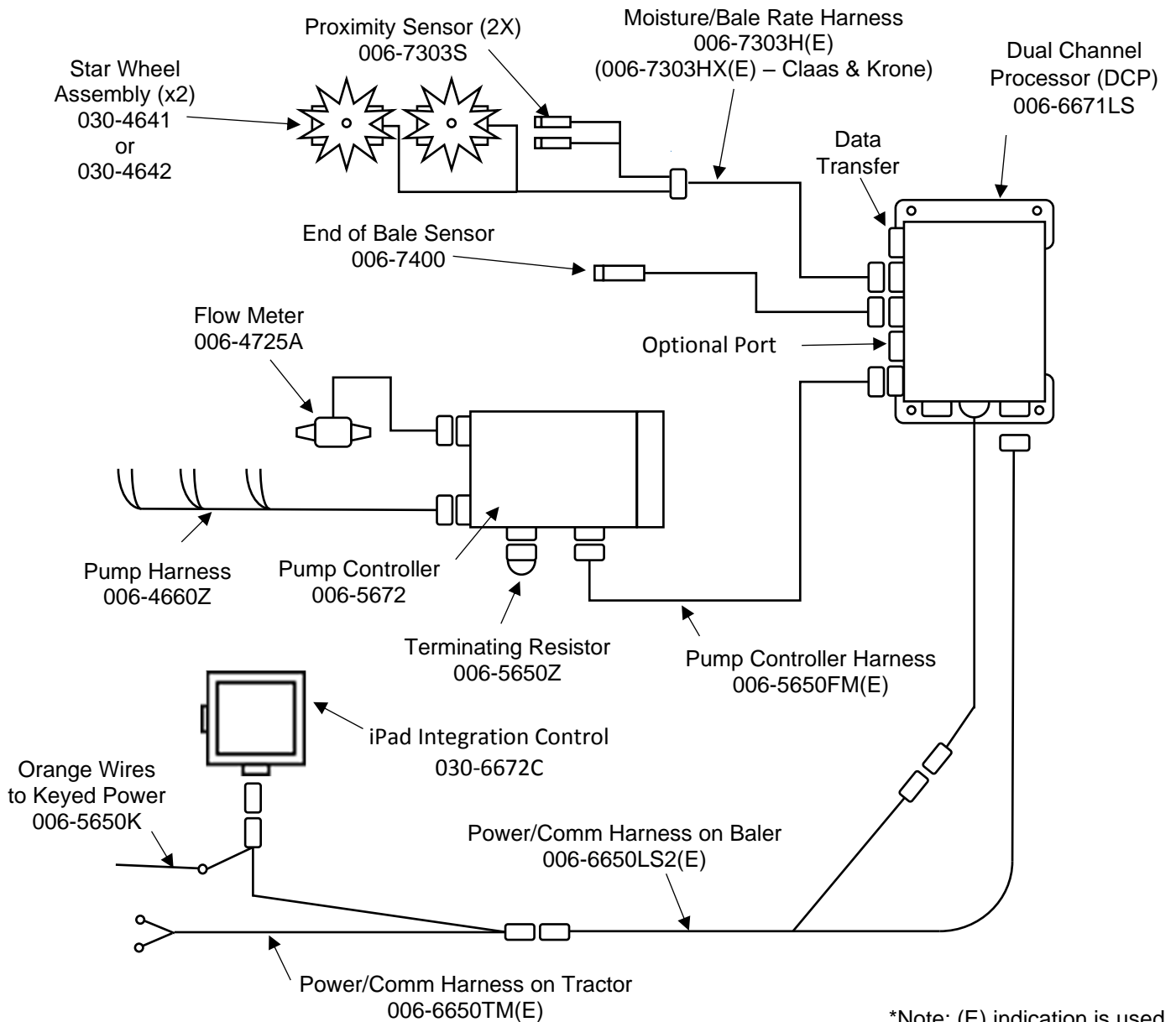

*Note: (E) indication is used for International Dealers

*Claas 3200-3400 balers will have star wheel assembly 030-4642 for mounting on side of bale chamber