

Installation Manual

Model 770MWM & 771MWM

***Microwave Moisture Pre-Compression Chamber System
& End of Bale Chute System***



*Equipment and Products
for Quality Hay.™*

P.O. Box 63 • 2821 Harvey Street • Hudson, WI 54016
800-635-7468 • www.harvesttec.com

DECLARATION OF INCORPORATION



MANUFACTURER:

Harvest Tec Inc.
2821 Harvey St.
P.O. Box 63
Hudson, WI 54016, U.S.A.

REPRESENTATIVE ESTABLISHED IN COMMUNITY: Profitable Farming Company
Middle Barlington, Roborough
Winkleigh, Devon, EX19 8AG
ENGLAND

The person above certifies and declares that:

VIRTUAL MACHINE: Equipment mounted on a farm press and for the application of inoculants onto forage crops.

MODEL: 770MWM, 771MWM-INST/OPR – Imp&Metric

BRAND: Harvest Tec

PATENT NUMBER: US 9,854,743 B2:

This application preservatives for hay Harvest Tec system meets the Directive 2006/42/EC of the European Parliament and the Council of 17 May 2006 and other applicable European Directives including Directive 2004/108/EC on the Electromagnetic compatability.

The application of preservatives for hay Harvest Tec system will be turned on after being installed on a farm press has been declared in conformity with the Machinery Directive.

Person in the community authorized to provide information on the partly completed machinery and making this statement:

Richard Snell, President, Profitable Farming Company

Signed on May 21, 2011: Middle Barlington, Roborough
Winkleigh, Devon, EX19 8AG
ENGLAND

770MWM & 771MWM Installation Manual Table of Contents

	Page
Introduction	4
System Requirements	4
Tools Needed	4
Installation of the Moisture Sensor	5-10
Microwave Moisture Installation 700MWM	5-7
Microwave Stuffer Sensor Installation 700MWM & 701MWM	8
Microwave Harness Installation 700MWM	9
Microwave Moisture Installation 701MWM	9
Microwave Harness Installation 701MWM	10
Microwave Harness Integration 700MWM & 701MWM	10
Microwave Moisture System Setup	11-13
Wiring Diagram - 770MWM	14
Wiring Diagram - 771MWM	15
Pin Outs	16-18
Common Questions	19
Troubleshooting	20
Parts Breakdown	21-22
Microwave Moisture Pre-Compression System 770MWM	21
Microwave Moisture Bale Chute System 771MWM	22
Warranty Statement	23

Introduction

Congratulations and thank you for purchasing a Harvest Tec Model 770MWM, 771MWM Microwave Moisture upgrade kit to 700 series moisture only kits or 700 series automatic applicator for Large Square Balers. Please read this manual carefully to ensure correct steps are taken to attach the system to the baler. This is designed to display moisture through the baler's monitor or customer supplied tablet. A parts breakdown of the system is located in the back of the manual.

Right and Left sides are determined by facing in the direction of forward travel.

System Requirements for integration into baler display

CNH Balers



**The Baler Control Module (BCM)
must have Version 4.2.0.0 or higher.**



AGCO Balers



**The Baler Processor must have Version 3.3 or higher.
C1000 must have version 3.0.1 or higher**



John Deere 330/340 Balers



**The Baler must have Software Version 2.0.7 or higher
GreenStar 4th Generation Arm Command Display must have version 8.10.2393-23**



System Requirements for tablet display

***Requirement to run iPad option are 3rd Generation iPad (2012) with
current operating system, plus the Precision Bale App.**

***Requirement to run Android option are with
Google Play 5 or greater operating system, plus the Precision Bale App.
*Not compatible with Kindle Fire tablet.***

Tools Needed:

Standard wrench set
Electric drill and bits
Side cutter
Standard nut driver set
Standard socket set

Hammer
Center punch
Plasma cutter
Grinding wheel

Microwave Sensor Installation AGCO 21/2200 series (3x3 and 3x4) balers (right side view) - 770MWM

Begin by opening the side shields on the baler and go to the right side of the baler so you can see the right side of the pre-compression chamber (PCC). Locate the mounting template in the kit. Removed the bolt (red arrow in figure 1) that attached the linkage that is in the way and position the linkage out of the way.

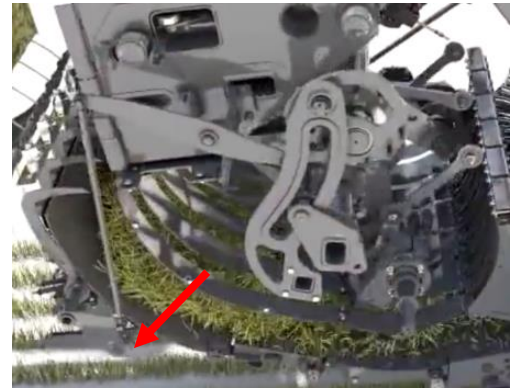

Figure 1

Locate the right-side sheet of the PCC and locate the two slotted holes along the front edge that attach the stripper band to the PCC side sheet. Align the slots on the template with the slots on the side sheet (figure 2). Clamp the template in place and use a marker or paint pen to mark the location for the eight holes that will need to be drilled and mark the rectangular area that will be cut out (figure 3).

Figure 2

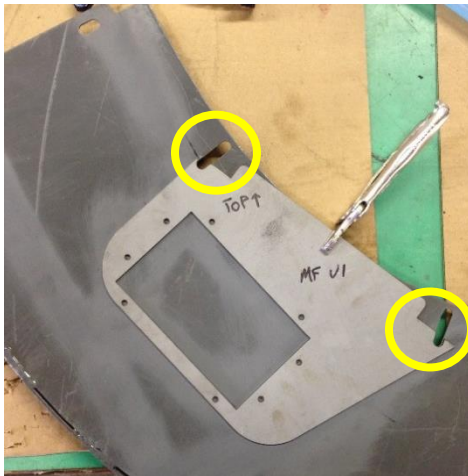
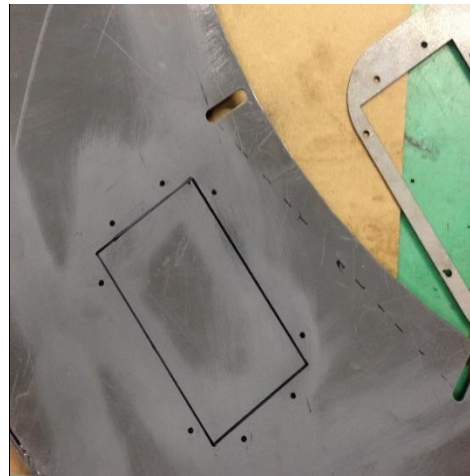

Figure 3



Microwave Sensor Installation – Massey Ferguson 2190 & 2290 Baler (left side view) - 770MWM

Align the curved edge of the template with the curved edge of the pre-compression chamber. Align the template so the straight top edge is parallel and 5-1/2" below the edge of the angle bracket. Clamp the template in place to the side of the pre-compression chamber and mark 8 holes and cutout locations. Mirror on opposite side (figure 4).

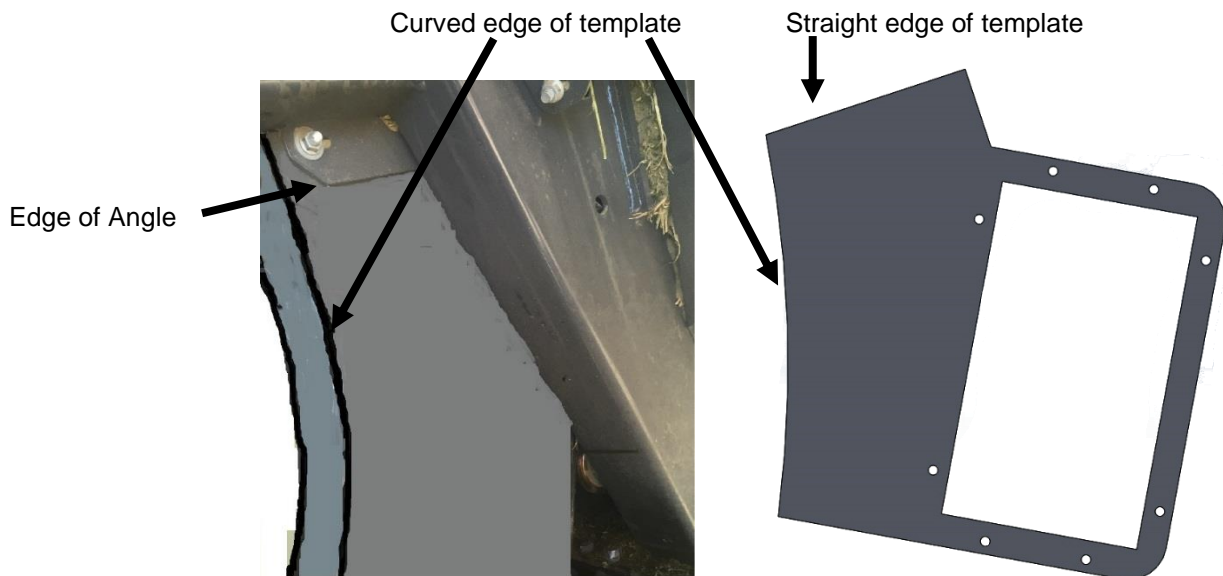

Figure 4

Microwave Sensor Installation – Case/New Holland (right side view) - 770MWM

Begin by opening the front shield, twine box doors, and pre-compression chamber (PCC) shield doors. Locate the mounting template in the kit and go to the right side of the baler.



Figure 1

Follow the curvature of the PCC and locate the fillet weld at the top. Index the bottom of that weld with the point at the top of the curved edge of the template (figure 2). The top and bottom points of the curved edge should align with the radius of the PCC (figure 3). Hold the template in place and use a marker or paint pen to mark the location for the eight holes that will need to be drilled and mark the rectangular area that will be cut out.

Figure 2



Figure 3



Microwave Sensor Installation 770MWM (continued)

In the eight locations indicated by the marks, drill 3/8" (10mm) diameter holes for the mounting bolts. Cut the rectangular area out using a grinder with cutoff wheel, reciprocating saw, or plasma cutter. Final results should look similar to the picture (figure 5). Test the fitment by placing the plastic filler plate (001-2600FP) in the rectangular hole. If the filler plate extrusion does not fully fit in the cutout, modify the cutout until the flanges of the filler plate fit flush against the outside of the PCC (figure 6).

Figure 5

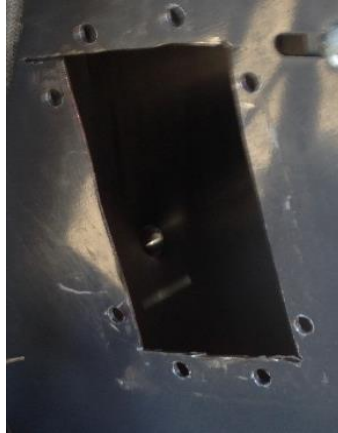
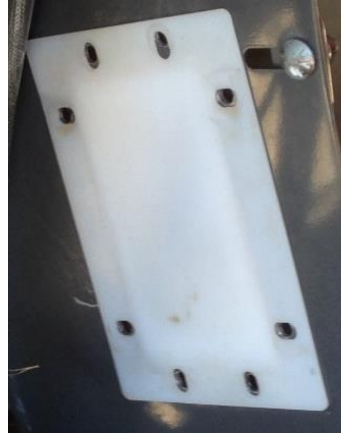

Figure 6



Install eight bolts 5/16"x 1" BHCS from the inside of the pre-compression chamber through the side of the PCC and the plastic filler plate (001-2600FP). Secure the top two bolts and bottom two bolts with 5/16" flanged nuts. Place a mounting bracket over each of the two bolts on the sides of the filler plate and secure with 5/16" flanged nuts (figure 7).

The right-hand side mounting brackets (001-2600) should be aligned parallel with the long edges of the filler plate. Locate the sensor that says RX on the gray connector and mount it to the brackets using four 5/16-3/4" bolts and flanged nuts (figure 8). The grey connector should be pointing down toward the ground.

Figure 7



Figure 8



Repeat the procedure on the left side of the PCC for marking the locations, drilling, and cutting, and mounting. The sensor labeled TX on the gray connector needs to be mounted on the left-hand side with the connector towards the ground.

Microwave Stuffer Sensor Installation 770MWM, 771MWM

Installation of stuffer sensor is required for both 770MWM & 771MWM microwave position.

Locate the 006-7401 harness (stuffer sensor) and the L-shaped bracket (001-4648SS) from the parts bag. Attach the stuffer sensor to the bracket loosely and locate the shielding on the right-hand side of the baler ahead of the stuffer.

Position the stuffer sensor and L-bracket against the outside of the shield so the sensor is positioned within 3/8" (10mm) of the stuffer (figure 9). Bending of the L-bracket may be required to avoid contact of precompression stuffer with sensor when in home position. Mark mounting hole location and attach bracket to the shielding using at least one of the 5/16-1" hex bolts and a flange nut. Secure the sensor to the bracket by tightening the jam nuts.



Figure 9

Route the wire from the sensor along the existing wiring along the frame towards the rear of the PCC (figure 10). Connect to 3 pin triangular plug on 006-7650MW or 7650MWL main harness. Secure with cable ties.

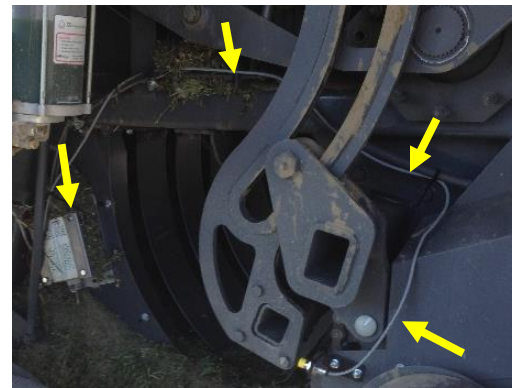

Figure 10

Microwave Harness Installation 770MWM

Locate the MWM wiring harness (006-7650MW) in the kit. Start by locating the connector with the white heat shrink label marked RX. Connect this connector to the sensor mounted on the right side of the PCC (006-4641MRX). Locate the longer lead that is labeled TX. Route this wire behind the PCC in an area where it will not be pinched or snagged.

Locate the bearing on each side of the PCC (figure 11). It works well to route the wire across to the other side by routing the wire below that pivoting assembly and securing with cable ties. Connect the connector labeled TX to the MWM sensor on the left hand side (006-4641MTX). Secure excess harness slack with cable ties.



Figure 11

Route the rest of the harness along the existing wiring toward the top of the chamber. The wire from the 006-7401 stuffer sensor will be connected to the 3-pin triangular connector coming off the 006-7650MW microwave harness about 2' (.6M) from the right-hand sensor.

Route the MWM harness (006-7650MW) to the front of the baler along the main 006-765B2 harness from the 700 series applicator or moisture only kit. Secure harness with cable ties. Connection will be made using 006-765MWM-EXT plug to the round Deutsch plug at the front of the 006-765B2 harness. See Microwave Harness integration section.

Microwave Moisture Installation 771MWM – Brackets/Sensors

Locate the mounting holes on the back of both the left and right side of the bale chute (figures 1 & 2).

Mount the rear microwave moisture mounting brackets 001-2601 (figure 3) on the holes using two 3/8" x 3 1/2" hex bolts, nuts and lock washers located in parts bag. **NOTE** - Some baler models may require bracket modification. Ensure no chains or other moving parts may interfere with mounting of microwave sensors. If baler is equipped with chute, carefully raise, and lower it to make sure it does not interfere with microwave sensors.

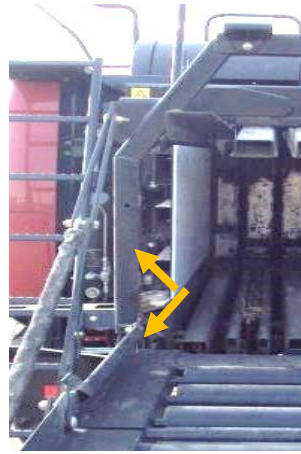

Figure 1



Figure 2

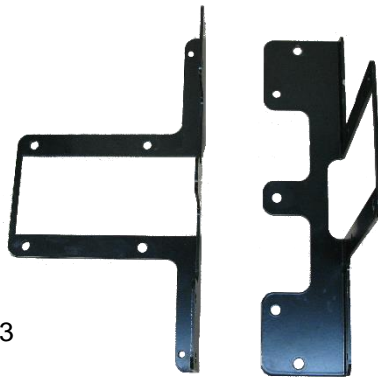

Figure 3

Attach the microwave moisture sensors to each mounting bracket. Sensor 006-4641MTX will be mounted on the left side of the bale chute (figure 4). Sensor 006-4641MRX will be mounted on the right side (figure 5). Mount the sensors with the wire connection port toward the baler.



Figure 4



Figure 5

Microwave Harness Installation 771MWM

Locate the MWM wiring harness (006-7650MWL) in the kit. Start by locating the connector with the white heat shrink label marked RX. Connect this connector to the sensor mounted on the right-side chute (006-4641MRX).

Route the rest of the harness toward the top of the chamber. Continue routing connector with the white heat shrink label marked TX to the sensor mounted on the left side of the chute (006-4641TX).

Route the MWM harness (006-7650MWL) to the front of the baler along the main 006-765B2 harness from the 700 series applicator or moisture only kit most commonly found on the RH side of the baler. The wire from the 006-7401 stuffer sensor will be connected to the 3-pin triangular connector coming off the 006-7650MWL microwave harness (006-7401MXT extension harness is required). Secure harnesses with cable ties. Connection will be made using 006-765MWM-EXT plug to the round Deutsch plug at the front of the 006-765B2 harness. See Microwave Harness integration section.

Microwave Harness Integration – 770MWM and 771MWM

Locate the MWM integration harness (006-765MWM-EXT) in the kit. Locate the round Deutsch Plug connector at the front of the 006-765B2 harness (Figure 1). With needle nose pliers remove white plugs from back of plug found in pin placement 11, 12, 13, & 14 (Figure 2).

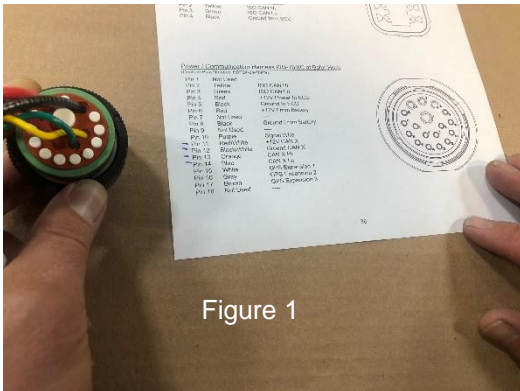

Figure 1



Figure 2

Insert pins from 006-765MWM-EXT harness into corresponding plug pin # (Figure 3). Reference wire pinout “Power / Communication Harness 006-7651C at Baler Hitch” in pin out section and the chart below to locate wire color with corresponding plug pin #. Connect 4 pin Deutsch male plug from 006-765MWM-EXT to female plug on microwave harness (006-7650MW(L)) routed to the front of baler (Figure 4)

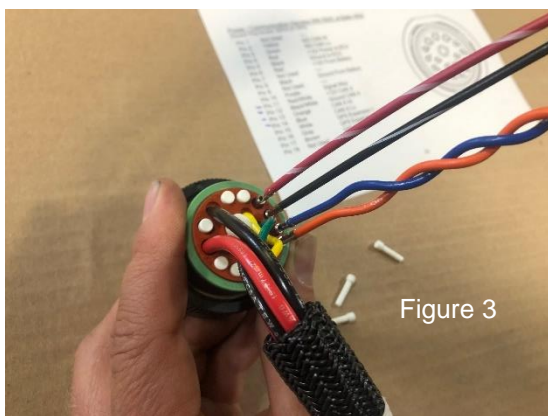

Figure 3

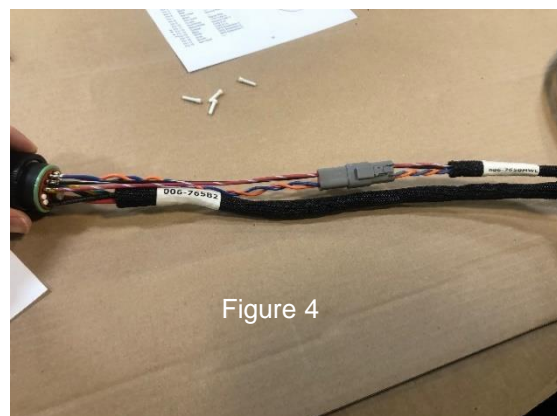

Figure 4

Pin Outs for MWM Integration Harness (006-765MWM-EXT)	
PIN 11	RED/WHITE
PIN 12	BLACK/WHITE
PIN 13	ORANGE
PIN 14	BLUE

Microwave Moisture System Setup – 770MWM

Shown using tablet with PRECISION BALE APP -

Note – Screen layouts may differ slightly if setup is performed thru Baler Virtual Terminal

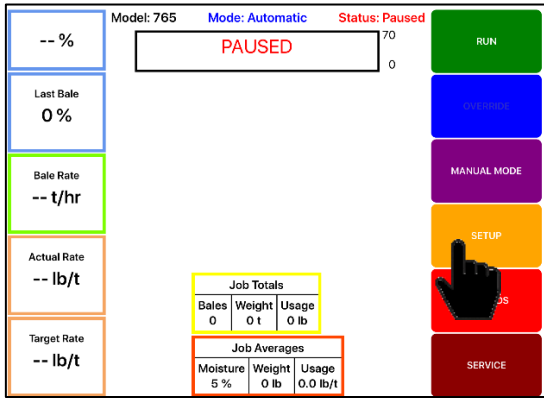

Press **SETUP**

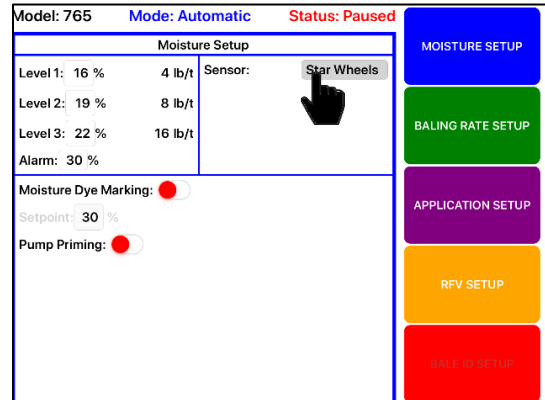

Press the **SENSOR** cell
Select **MWM PCC**

Selecting Baler OEM – MWM-PCC

1. To change the Baler OEM, select the gray cell to the right of **OEM**.
2. When the menu appears, select the correct Baler OEM by scrolling between AGCO, CNH, John Deere, and Krone.

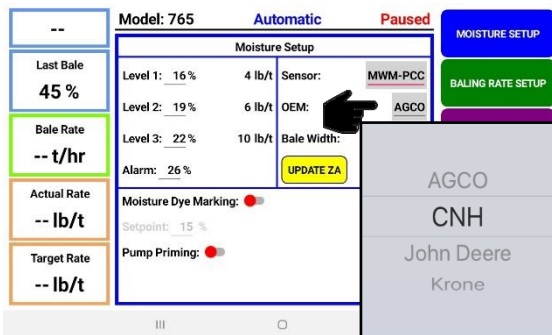

Set **OEM** to baler model: AGCO, CNH, JD, or Krone



Set **Bale Width** for baler type

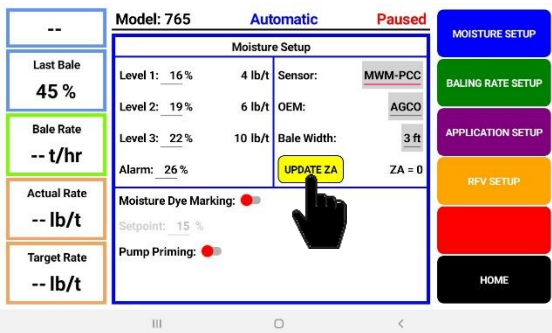

Press **Update ZA**

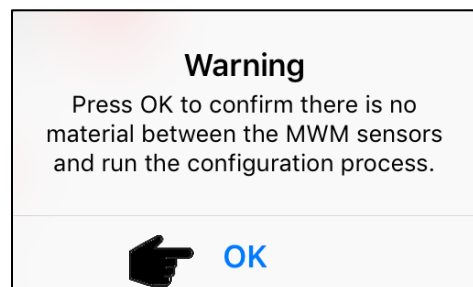

Bale Chamber must be clear to run Zero Adjust, then press **OK**

ZA RANGE (Zero Adjustment) Same for Chute or PCC Setup	
AGCO	2200 - 3000
CNH	2200 - 3000
John Deere	2200 - 3000
Krone	2200 - 3000
Other	2200 - 3000

If the reading is within range no adjustments need to be made.

This range is for both 3' and 4' (1M & 1.2M) wide balers

Microwave Moisture System Setup – 771MWM

Shown using tablet with PRECISION BALE APP - MWM-Chute.

Note – Screen layouts may differ slightly if setup is performed thru Baler Virtual Terminal

Press **SETUP**

Press the **SENSOR** cell
Select **MWM-CHUTE**

Selecting Baler OEM – MWM-Chute

1. To change the Baler OEM, select the gray cell to the right of **OEM**.
2. When the menu appears, select the correct Baler OEM by scrolling between AGCO, CNH, John Deere, and Krone.

Set **OEM** to baler model: AGCO, CNH, JD, or Krone

Set **Bale Width** for baler type

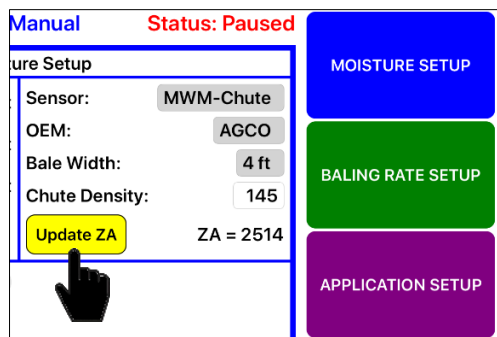

Press **Update ZA**

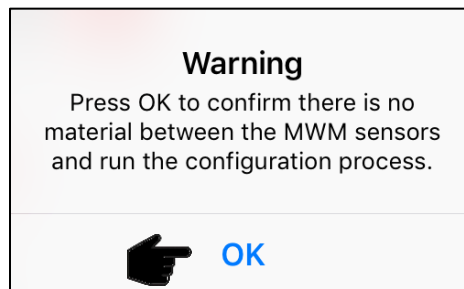

Bale Chamber must be clear to run Zero Adjust, then press **OK**

ZA RANGE (Zero Adjustment)	
Same for Chute or PCC Setup	
AGCO	2200 - 3000
CNH	2200 - 3000
John Deere	2200 - 3000
Krone	2200 - 3000
Other	2200 - 3000

If the reading is within range no adjustments need to be made.

****This range is for both 3' and 4' (1M & 1.2M) wide balers****

Moisture System Setup – CHUTE DENSITY – MOISTURE OFFSETTING

Note: Chute Density setting may be changed after calibration is complete to compensate for various crop types and allow for minor moisture reading adjustments. Density is based on the dry weight of the bale. The default setting is 145kg/m³. **Lower density settings will result in higher moisture readings.** Density adjustment range is currently 100-400kg/m³.

770MWM Upgrade - Wiring Diagram – Connecting to 700 Series Preservative Applicator System

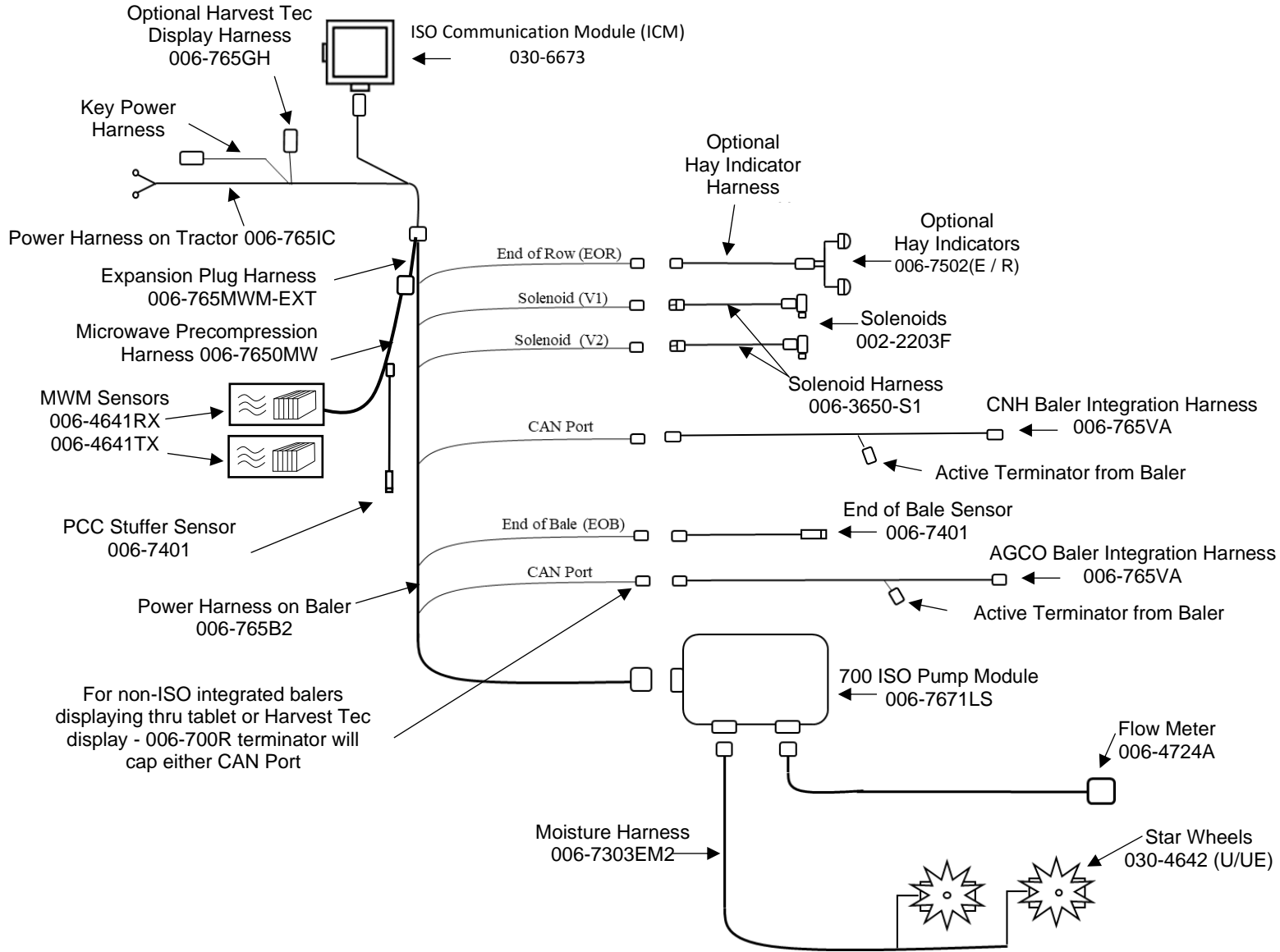

771MWM Upgrade - Wiring Diagram – Connecting to 700 Series Preservative Applicator or Moisture Only System

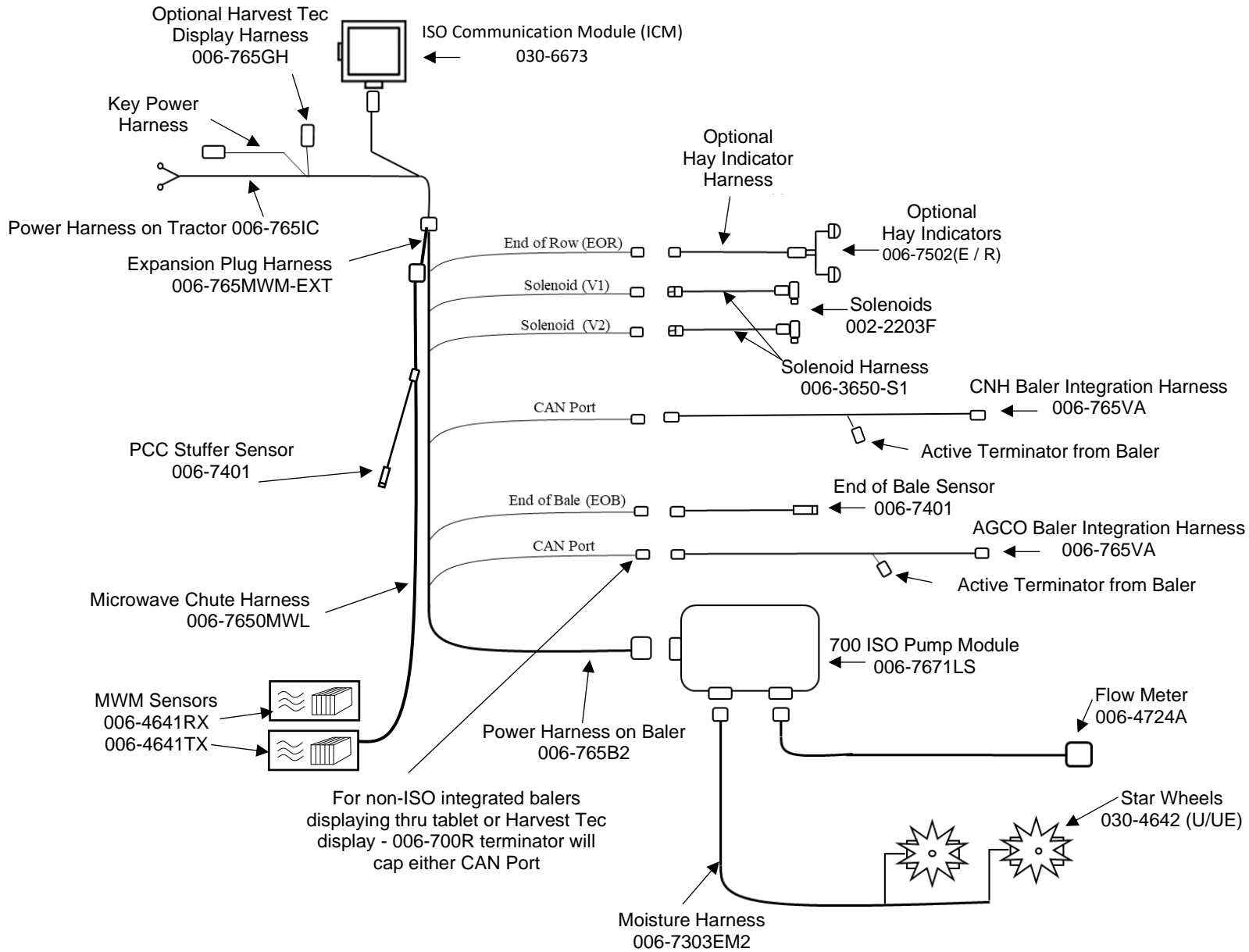

Microwave Operation 770MWM, 771MWM

Pin Outs

Integrated Control Module (ICM) on harness 006-765IC

(Deutsch Plug Number: DTM06-12SA)

Pin 1	Red	+12V from ECU
Pin 2	Purple	Signal Wire
Pin 3	Red/White	+12V CAN X
Pin 4	Black/White	Ground CAN X
Pin 5	Orange	CAN X Hi
Pin 6	Blue	CAN X Lo
Pin 7	Green	ISO CAN Lo
Pin 8	Yellow	ISO CAN Hi
Pin 9	White	GPS Expansion 1
Pin 10	Gray	GPS Expansion 2
Pin 11	Brown	GPS Expansion 3
Pin 12	Black	Ground from ECU

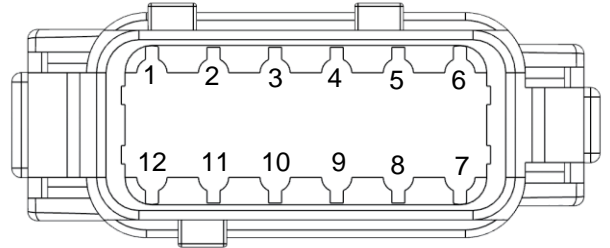

ISOBUS Plug on harness 006-765IC

(Deutsch Plug Number: DT04-4P)

Pin 1	Red	+12V from ECU
Pin 2	Yellow	ISO CAN Hi
Pin 3	Green	ISO CAN Lo
Pin 4	Black	Ground from ECU

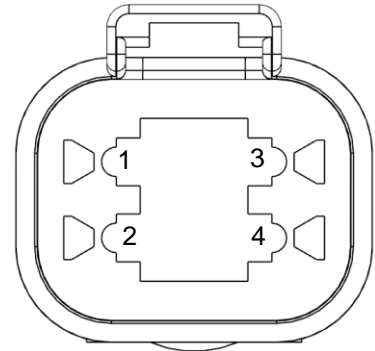

Power / Communication Harness 006-765IC at Baler Hitch

(Deutsch Plug Number: HDP24-24-18PN)

Pin 1	Not Used	----
Pin 2	Yellow	ISO CAN Hi
Pin 3	Green	ISO CAN Lo
Pin 4	Red	+12V Power to ECU
Pin 5	Black	Ground to ECU
Pin 6	Red	+12V From Battery
Pin 7	Not Used	----
Pin 8	Black	Ground From Battery
Pin 9	Not Used	----
Pin 10	Purple	Signal Wire
Pin 11	Red/White	+12V CAN X
Pin 12	Black/White	Ground CAN X
Pin 13	Orange	CAN X Hi
Pin 14	Blue	CAN X Lo
Pin 15	White	GPS Expansion 1
Pin 16	Gray	GPS Expansion 2
Pin 17	Brown	GPS Expansion 3
Pin 18	Not Used	----

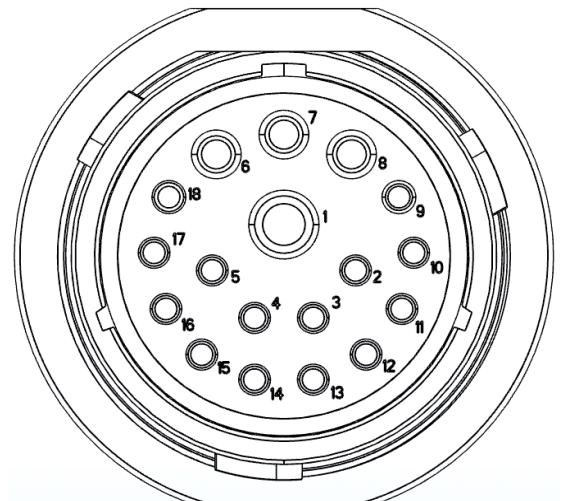

Power / Communication Harness 006-765B2 at Baler Hitch IPM

(Deutsch Plug Number: HDP26-24-18SN)

Pin 1	Not Used	----
Pin 2	Yellow	ISO CAN Hi
Pin 3	Green	ISO CAN Lo
Pin 4	Red	+12V Power to ECU
Pin 5	Black	Ground to ECU
Pin 6	Red	+12V From Battery
Pin 7	Not Used	----
Pin 8	Black	Ground From Battery
Pin 9	Not Used	----
Pin 10	Orange/White	+12V Power to EOR
Pin 11	Not Used	----
Pin 12	Not Used	----
Pin 13	Not Used	----
Pin 14	Not Used	----
Pin 15	Not Used	----
Pin 16	Not Used	----
Pin 17	Not Used	----
Pin 18	Not Used	----

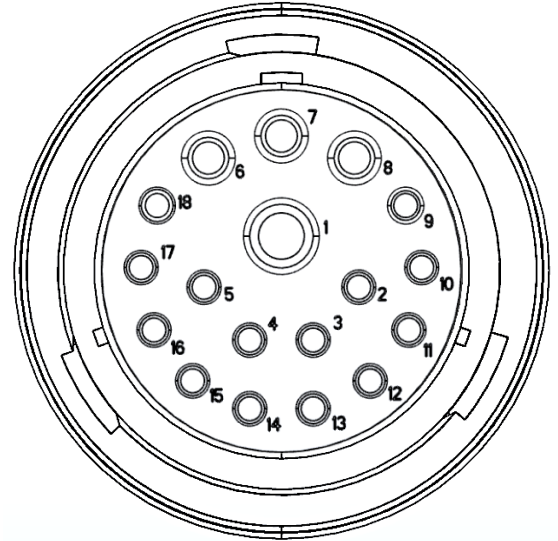

Power / Communication Harness 006-765B2 at IPM Module

(Deutsch Plug Number: HDP24-24-18SN)

Pin 1	Not Used	----
Pin 2	Yellow	ISO CAN Hi
Pin 3	Green	ISO CAN Lo
Pin 4	Red	+12V Power to ECU
Pin 5	Black	Ground to ECU
Pin 6	Red	+12V From Battery
Pin 7	Not Used	----
Pin 8	Black	Ground From Battery
Pin 9	Not Used	----
Pin 10	Orange/White	+12V Power to EOR
Pin 11	Orange/Black	Ground to EOR
Pin 12	Purple/Green	EOR Signal
Pin 13	Blue/White	EOB Signal
Pin 14	Gray/Red	+12V Power to Solenoid 1
Pin 15	White/Black	Ground to Solenoid 1
Pin 16	Orange/Red	+12V Power to Solenoid 2
Pin 17	White/Black	Ground to Solenoid 2
Pin 18	Not Used	----

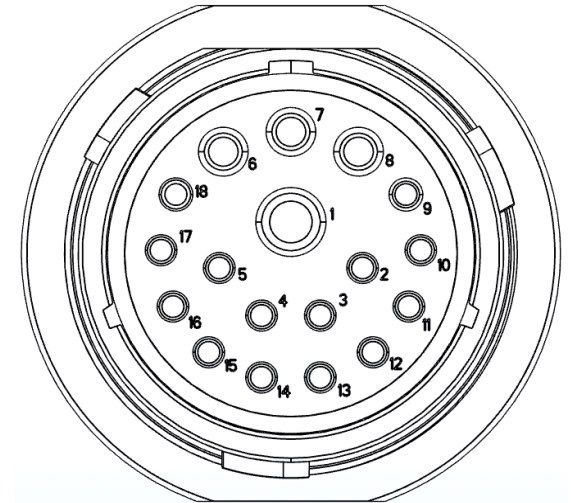

Solenoid 1 Plug on Baler Harness 006-765B2

(Deutsch Plug Number: APTIV 12052641)

Pin B	Gray/Red	+12V to Solenoid 1
Pin A	White/Black	Ground to Solenoid 1

Solenoid 2 Plug on Baler Harness 006-765B2

(Deutsch Plug Number: APTIV 12052641)

Pin B	Orange/Red	+12V to Solenoid 2
Pin A	White/Black	Ground to Solenoid 2

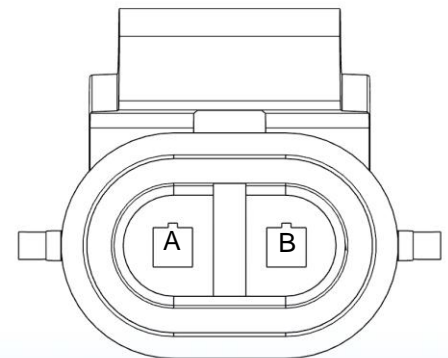

CAN / IDM on Baler Harness 006-765B2

(Deutsch Plug Number: DT06-4S)

Pin 1	Red	+12V to ECU
Pin 2	Yellow	ISO CAN Hi
Pin 3	Green	ISO CAN Lo
Pin 4	Black	Ground to ECU

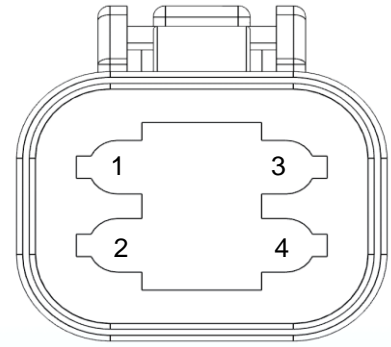

End of Bale Sensor Plug on Baler Harness 006-765B2

(Deutsch Plug Number: DT06-3S)

Pin 1	Orange/White	+12V to End of Bale Sensors
Pin 2	Orange/Black	Ground to End of Bale Sensors
Pin 3	Blue/White	Signal

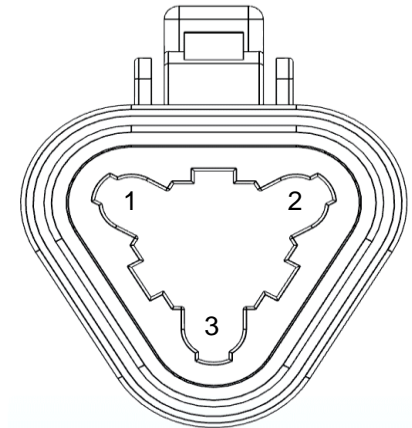

End of Row Sensors Plug on Baler Harness 006-765B2

(Deutsch Plug Number: DT06-3S)

Pin 1	Orange/White	+12V to End of Bale Sensors
Pin 2	Orange/Black	Ground to End of Bale Sensors
Pin 3	Blue/White	Signal

Integration Harness Plug on Baler Harness 006-765VA

(Plug: APTIV 12052848)

Pin A	Not Used	----
Pin B	Red	TBC Power
Pin C	Not Used	----
Pin D	Gray	TBC Ground
Pin E	Orange	CAN Hi
Pin F	Blue	CAN Lo

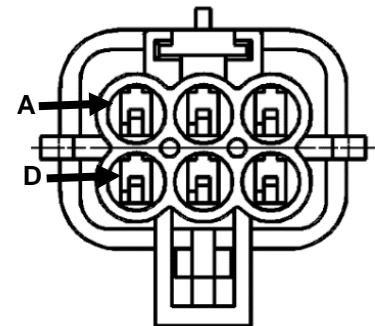

Pump Connection on 700 Controller Harness

(16 AWG Two-Wire Plug)

Pin 1	Red	Power to Pump
Pin 2	Black	Ground to Pump

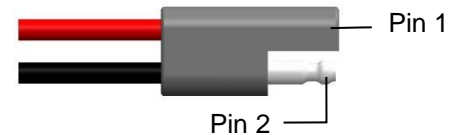

Common Questions

1. What terminal is required to operate microwave sensor?

Microwave sensors are compatible with select AGCO, Case, New Holland, and Krone baler Virtual Terminals & Apple/Android tablets with Precision Bale App (see System Requirements pg. 4).

2. What moisture range will sensors detect?

Pre-Compression Chamber microwave sensors have a moisture range of 6-60% moisture. The Bale Chute chamber sensors have a range of 6-40%.

3. What crops are the microwave sensors designed for?

The Microwave sensors are designed and calibrated for Alfalfa.

4. Is there a calibration to the microwave sensors for different crops?

No, there is no adjustments needed. However, the back of bale chamber 771MWM density setting can be adjusted to offset the moisture reading should the operator observe moisture readings are above or below the actual bale moisture. The greater the density setting the lower the moisture reading. Decreasing the density setting will increase the moisture read out. This can only be adjusted when MWM-CHUTE is selected in the Moisture Setup setting.

5. Do the sensors emit harmful waves?

No

6. How often should a Zero Adjust (ZA) be performed?

A zero adjust should be performed on initial installation. It is also recommended during a zero adjust calibration at the beginning of each season.

7. When reading moisture with microwave sensors why can I not select Automatic mode?

MWM Pre-Compression sensors can be used in both Auto and Manual mode.

MWM Bale Chute sensors can only be used in Manual Mode due to the distance between sensor placement and application of preservative.

8. Where do I position 740DM moisture dye marker spray tip when operating microwave sensors?

Dye marking tips should be located behind (toward rear end of chute) with MWM Chute sensors, with the tips angled toward the rear at a 45-degree angle. Alternative mounting would locate the dye marking tips above the bale w/ the brackets mounted off the top cross beam.

When using a Pre-Compression system mount the tips as close to the front of the bale chamber as possible, either on the side if there is clearance or on the top of the bale with the understanding the dye will be offset approximately 4 flakes from where moisture is detected.

9. Should the light blink green or remain solid on the ICM module 030-6673?

Blinking Green Light – When properly connected to a Virtual terminal or tablet (with the Precision Bale App), the blinking green light will indicate good connection

Troubleshooting

PROBLEM	POSSIBLE CAUSE	SOLUTION
Moisture reading errors (high or low)	1. Wire disconnected or bad connection between sensors and ICM in cab of tractor	1. Reconnect wire.
	2. Low power supply to ICM	2. Check voltage at ICM box. (Min of 12 volts required.)
	3. Dry hay lower than 7% moisture or wet hay over 40%.	3. The Bale Chute system read 6-40% moisture.
	4. Short in wire between Microwaves and ICM.	4. Replace wire.
	6. Check hay with hand tester to verify.	6. Contact Harvest Tec if conditions persist.
Moisture readings erratic.	1. Test bales with hand tester to verify that MWM system has more variation than hand tester.	
	2. Check all wiring connections for corrosion or poor contact.	2. Apply dielectric grease to all connections.
	3. Check power supply at tractor. Voltage should be constant between 12 and 14 volts.	3. Install voltage surge protection on tractors alternator.
MWM moisture reads low all the time	1. Stuffer sensor out of adjustment 2. MWM – Chute is not properly selected in setup menu	1. Verify Stuffer sensor is not damaged and is sensing the precompression stuffer moving each time 2. Reference Moisture System setup section
ICM light will not illuminate	1. ICM receiver not connected 2. Harness disconnected Low power	1. Check connections and voltage. Minimum 12.5V needed. 2. Verify all pins in ICM are not damaged
Moisture displays as “error” in Harvest Tec object pool within VT or tablet*	1. Damaged precompression stuffer sensor 2. Faulty harness connection to microwave moisture sensors	1. Verify proximity sensor functioning in precompression 2. Verify moisture sensors properly connected
Moisture displays as “89” on baler work screen	3. No incoming crop	3. Feed crop into baler
*If ICM does not see a reading from the microwave sensor within 5 min while in RUN, system will display “error” / ”89%” until new reading is sent		

Microwave Moisture Pre-Compression System – 770MWM

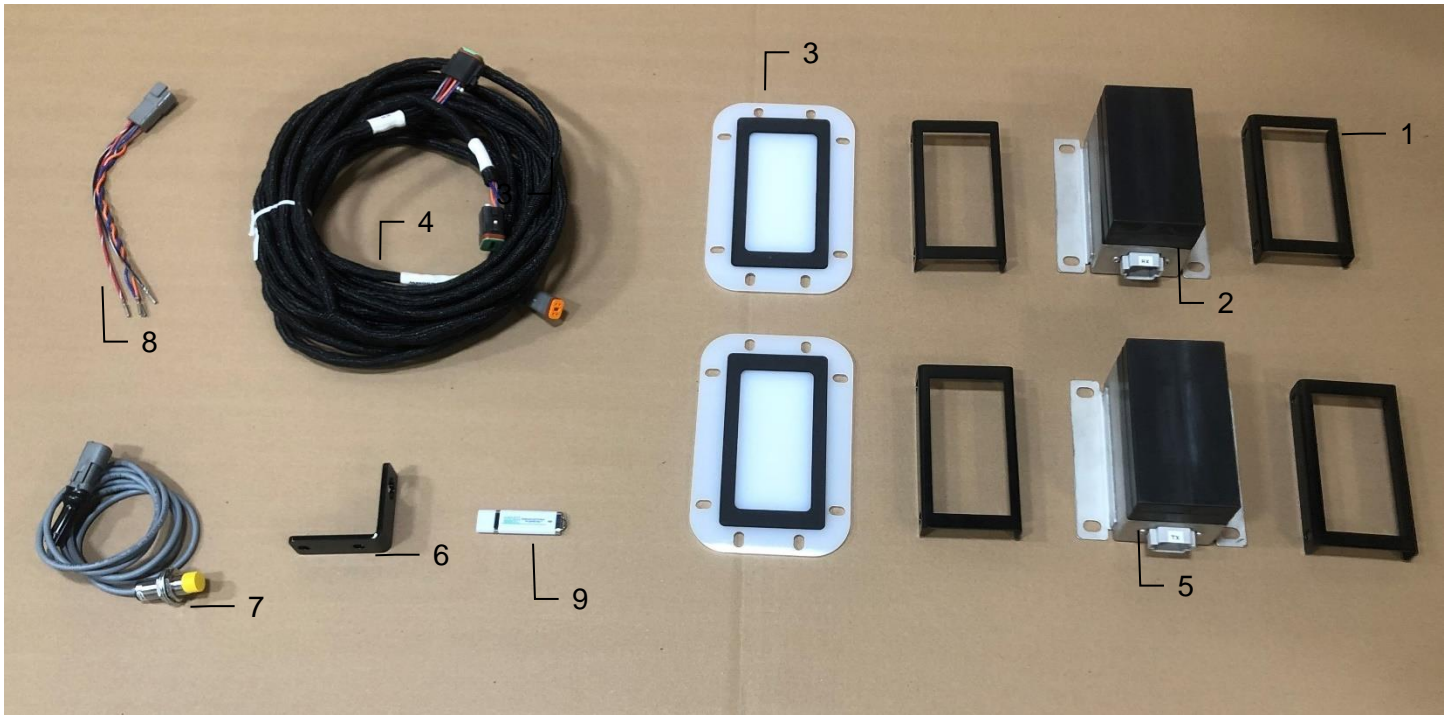

<u>Ref</u>	<u>Description</u>	<u>Part #</u>	<u>Qty</u>
1	MWM Mounting Bracket	001-2600	4
2	Microwave TX Sensor	006-4641MTX	1
3	MWM Filter Plate	006-2600FP	2
4	MWM Pre-Compression Harness	006-7650MW	1
5	Microwave RX Sensor	006-4641MRX	1
6	End of Bale Bracket (Stuffer Bracket)	001-4648SS	1
7	End of Bale Sensor (Stuffer Sensor)	006-7401	1
8	Expansion Plug for Baler Harness	006-765MWM-EXT	1
9	USB REMOVABLE STORAGE	006-5650USB	1

Complete Assembly 030-770MWM

Microwave Moisture Bale Chute System – 771MWM

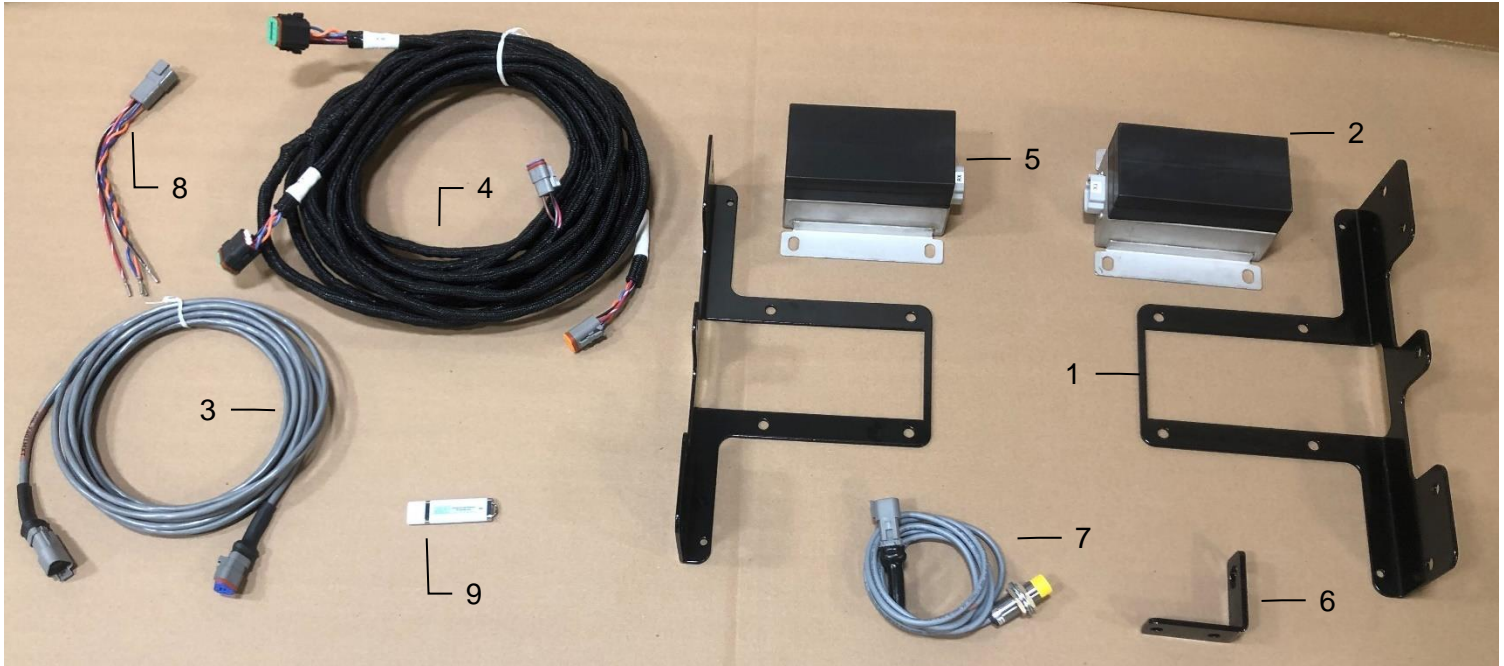

Ref	Description	Part #	Qty
1	MWM Rear Mounting Bracket	001-2601	2
2	Microwave TX Sensor	006-4641MTX	1
3	End of Bale Extension Harness (20')	006-7401MXT	1
4	MWM Chute Harness	006-7650MWL	1
5	Microwave RX Sensor	006-4641MRX	1
6	End of Bale Bracket (Stuffer Bracket)	001-4648SS	1
7	End of Bale Sensor (Stuffer Sensor)	006-7401	1
8	Expansion Plug for Baler Harness	006-765MWM-EXT	1
9	USB REMOVABLE STORAGE	006-5650USB	1
NP	Power / Comm Extension Harness (25')	006-765FMX	1

Complete Assembly 030-771MWM
 (Ref 1-9)

Harvest Tec Inc. Warranty and Liability Agreement

Harvest Tec, Inc. will repair or replace components that are found to be defective within 12 months from the date of manufacture. Under no circumstances does this warranty cover any components which in the opinion of Harvest Tec, Inc. have been subjected to negligent use, misuse, alteration, accident, or if repairs have been made with parts other than those manufactured and obtainable from Harvest Tec, Inc.

Our obligation under this warranty is limited to repairing or replacing free of charge to the original purchaser any part that in our judgment shows evidence of defective or improper workmanship, provided the part is returned to Harvest Tec, Inc. within 30 days of the failure. If it is determined that a non-Harvest Tec branded hay preservative has been used inside the Harvest Tec applicator system where the failure occurred, then Harvest Tec reserves the right to deny the warranty request at their discretion. Parts must be returned through the selling dealer and distributor, transportation charges prepaid.

This warranty shall not be interpreted to render Harvest Tec, Inc. liable for injury or damages of any kind, direct, consequential, or contingent, to persons or property. Furthermore, this warranty does not extend to loss of crop, losses caused by delays or any expense prospective profits or for any other reason. Harvest Tec, Inc. shall not be liable for any recovery greater in amount than the cost or repair of defects in workmanship.

There are no warranties, either expressed or implied, of merchantability or fitness for particular purpose intended or fitness for any other reason.

This warranty cannot guarantee that existing conditions beyond the control of Harvest Tec, Inc. will not affect our ability to obtain materials or manufacture necessary replacement parts.

Harvest Tec, Inc. reserves the right to make design changes, improve design, or change specifications, at any time without any contingent obligation to purchasers of machines and parts previously sold.

Revised 4/17

HARVEST TEC, INC.
P.O. BOX 63
2821 HARVEY STREET
HUDSON, WI 54016
PHONE: 715-386-9100
1-800-635-7468
FAX: 715-381-1792
Email: info@harvesttec.com