

# Installation Manual

***Model 700J***

***Moisture Sensor Kit for John Deere Large***



*Equipment and Products  
for Quality Hay.™*

---

P.O. Box 63 • 2821 Harvey Street • Hudson, WI 54016  
800-635-7468 • [www.harvesttec.com](http://www.harvesttec.com)

**DECLARATION OF INCORPORATION**



**MANUFACTURER:**

Harvest Tec Inc.  
2821 Harvey St.  
P.O. Box 63  
Hudson, WI 54016, U.S.A.

**REPRESENTATIVE ESTABLISHED IN COMMUNITY:** Profitable Farming Company  
Middle Barlington, Roborough  
Winkleigh, Devon, EX19 8AG  
ENGLAND

The person above certifies and declares that:

**VIRTUAL MACHINE:** Equipment mounted on a farm press and for the application of inoculants onto forage crops.

**MODEL:** 700J-INST-20-Imp&Metric

**BRAND:** Harvest Tec

**SERIAL NUMBER:**

This application preservatives for hay Harvest Tec system meets the Directive 2006/42/EC of the European Parliament and the Council of 17 May 2006 and other applicable European Directives including Directive 2004/108/EC on the Electromagnetic compatibility.

The application of preservatives for hay Harvest Tec system will be turned on after being installed on a farm press has been declared in conformity with the Machinery Directive.

Person in the community authorized to provide information on the partly completed machinery and making this statement:

**Richard Snell, President, Profitable Farming Company**  
Signed on May 21, 2011: Middle Barlington, Roborough  
Winkleigh, Devon, EX19 8AG  
ENGLAND

# Table of Contents

|   | <u>PAGE</u>  |
|---|--------------|
| <b>Introduction</b>   | <b>3</b>     |
| <b>System Requirements</b>  | <b>3</b>     |
| <b>Tools Needed</b>   | <b>3</b>     |
| <b>Installation of the Moisture Sensor Kit</b>                      | <b>4-6</b>   |
| Installation of Processor (IPM)                                     | 4            |
| Main Wire Harness and Baler Interface Harness routing & Connections | 4            |
| Installation of Star Wheels – Non-UHD Baler                         | 5            |
| Installation of Star Wheels – UHD Baler                             | 5            |
| Installation of End of Bale Sensor                                  | 6            |
| <b>Tractor Setup</b>  | <b>7</b>     |
| <b>Display Options</b>  | <b>8-9</b>   |
| Optional Tablet Display   | 8            |
| Optional Baler VT Integration                                       | 9            |
| Baler Display Integration   | 9            |
| Baler Monitor Setup   | 10-13        |
| <b>Wiring Diagram</b>   | <b>14</b>    |
| <b>Pin Outs</b>   | <b>15-17</b> |
| <b>Parts Breakdown</b>  | <b>18-19</b> |
| Star Wheel Sensors, Twine Diverters & Moisture Harness              | 18           |
| Control Box & Wiring Harnesses                                      | 19           |
| End of Bale Sensor Kit  | 19           |
| <b>Warranty</b>   | <b>20</b>    |

## Introduction

Thank you for purchasing a Harvest Tec moisture monitor system. This moisture monitoring system has been designed to be operated through a number of different displays and tablets using the Precision Baling App. These include, the Harvest Tec display, the baler's ISOBUS and display on the baler monitor, or iOS/Android Tablet (not included).

The 700 Series Moisture System is designed to show moisture through the balers ISOBUS. Failure to follow instructions can result in personal injury or equipment malfunction. If you need parts for the system, please view the Parts Breakdown toward the back of this manual and contact your local authorized dealer to order the parts.

## System Requirements

 **The Baler must have Software Version 2.0.7 or higher**  
**GreenStar 4<sup>th</sup> Generation Arm Command Display must have version 8.10.2393-23** 

**\*Made for Harvest Tec Display, Baler Integration, or Tablet\***  
**For best performance ensure all displays are running the latest operating system**

## Tools Needed

Standard Wrench set  
Electric drill and bits

Side cutter  
Standard Socket Set

Hammer  
Center Punch

## Installation of the Processor (IPM)

The locations shown are on the right twine box (looking from the back of the baler). Mark and drill the two 3/8 (10mm) holes and install the (IPM) with two 5/16 x 1 bolts, four 1/4" washers, and two 5/16" nylock nuts. Main harness whip coming out of (IPM) should point to the ground. When attaching other harness make sure to loop them below the (IPM) so as not to funnel water into the control.



## Main Wire Harness and Baler Interface Harness Routing and Connections

### John Deere L330 / L340 Balers Harness Routing and ISOBUS Connection



Route cords 006-765B2 along this path. Keep cords away from moving parts and hydraulic hoses. Secure with existing cable clamps or use cable ties. When all connections are made, secure wires as shown.

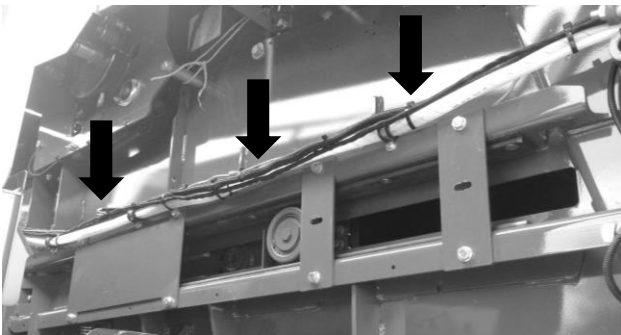

Route harness from IPM and ICM as shown in picture left, secure with cable ties.

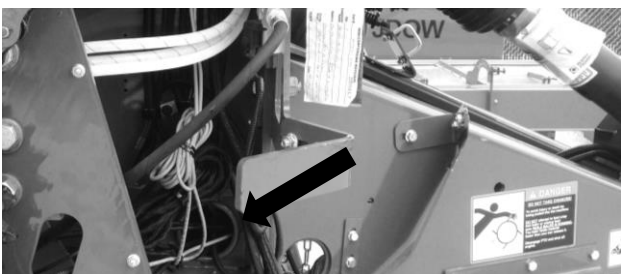

Route ISO Integration Harness (006-765VA) to opposite side of baler through support cylinder as shown in picture left.

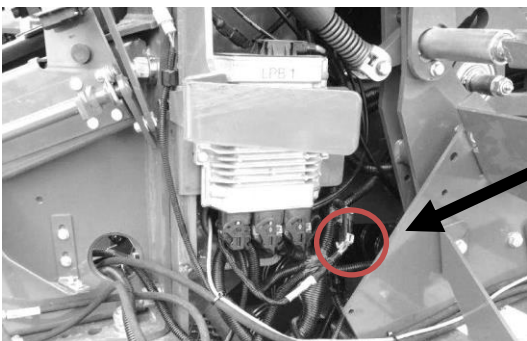

Locate harness 006-765VA and connect to baler interface harness next to baler's processor (below) on front left side of baler.

Remove baler terminating resistor and connect to short pigtail on 006-765VA Harness.

## Star Wheel Installation

Remove any material from the bale chute. The star wheels are to be mounted on the transition bracket on both sides of the bale chute located after knotters shown above. Holes have been installed at the factory, however you need to remove bracket and cut 3/4" (19mm) off the bracket as indicated below to allow proper spacing for star wheel assembly.

Once complete, touch up with spray paint to prevent rusting and place the carriage bolts that mount the transition bracket back in original bracket mounting holes (A) before mounting star wheel assembly (C). Insert the 5/16" x 3" Allen head bolts (B) up through the transition bracket. Place the star wheel block over the nuts. Place twine guard on top of star wheel (D).

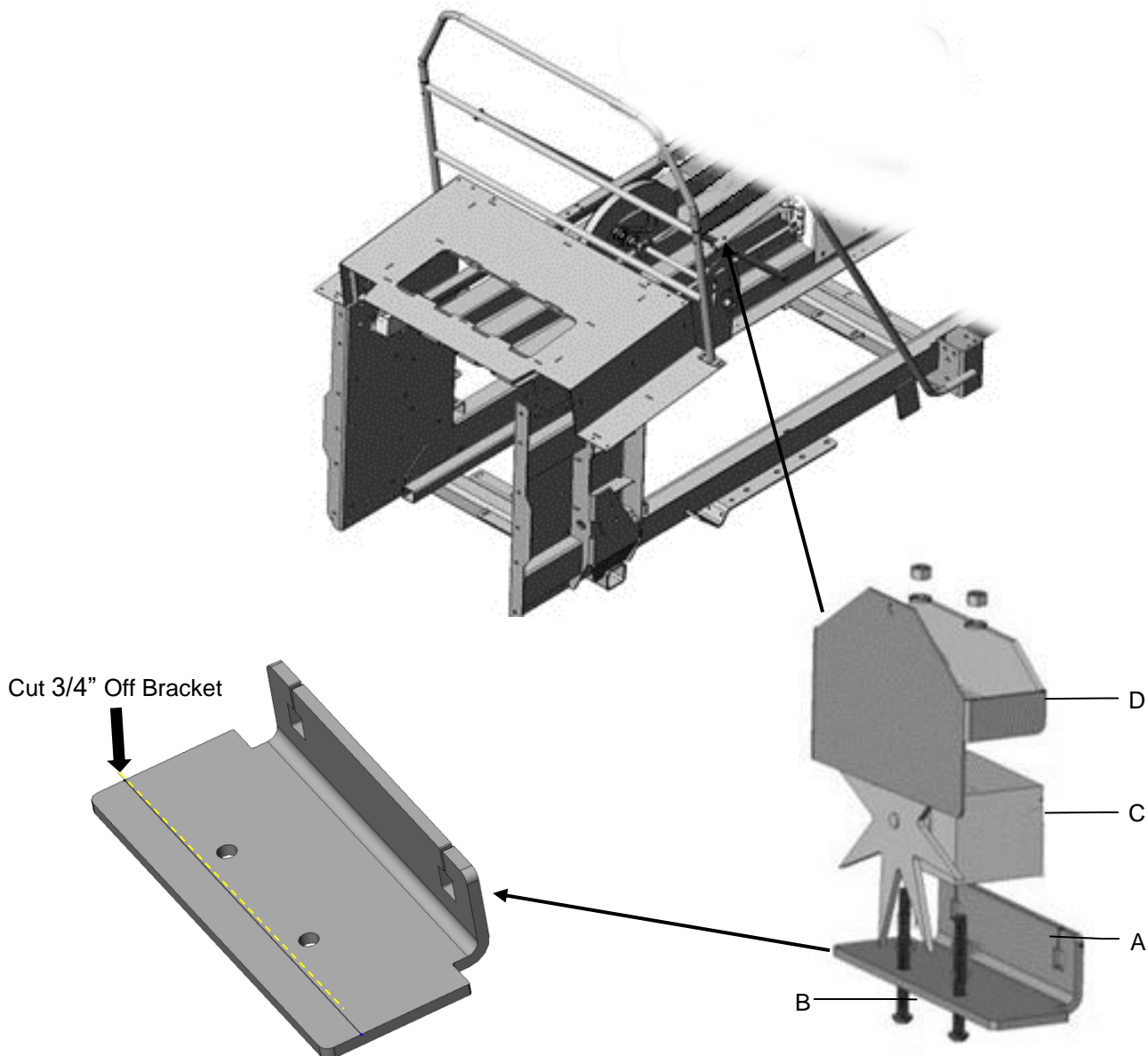

**Note: Star wheel with 6 position plug and twine diverter with extra holes needs to be mounted on right side of baler.**

## End of Bale Sensor Installation

The end of bale sensor determines the position of the needles on the baler. When the needle cycles the sensor communicates this information to the 700 series that a bale has been made. Installation of this sensor is required for use with the Harvest Tec job records. Reference "Sensor Settings" in Operation Manual.

End of bale sensor bracket (001-4648J) will be used.

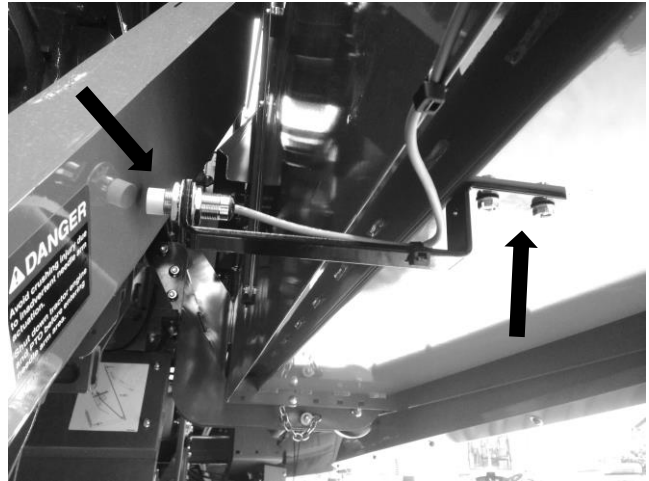
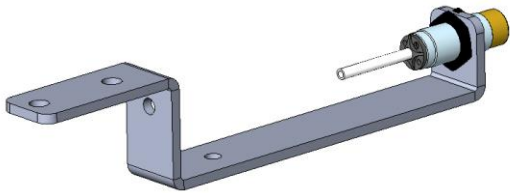

Mount the end of bale sensor bracket (001-4648J) as shown. Under the twine box mark and drill two 3/8" (10mm) holes and attach the bracket using two 5/16" x 1" self-tapping screws, and 5/16" flange nuts. Position the bolts so the bolt heads are inside the twine box, so they do not interfere with the twine. Mount the sensor in hole location centered alongside the needle arm, keep the sensor 1/4" (7mm) from the needle arm and tighten both nuts. Route the sensor wire along the bottom side of the twine box toward the twine box pivot point. Secure the wire to the twine box and around the pivot point to avoid damage to the wire. Once routed around the pivot point, connect the EOB sensor wire to the main baler harness (006-765B2).

## Tractor Setup

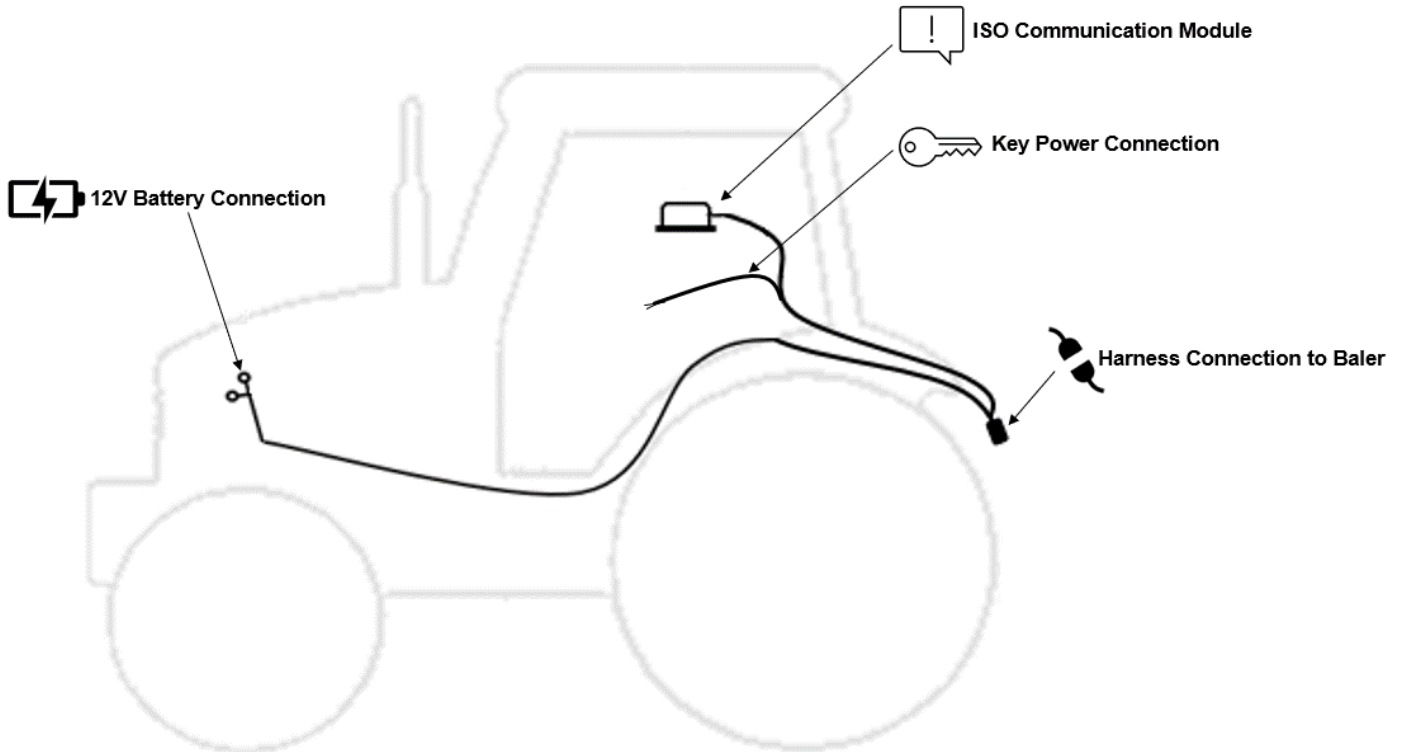

The general tractor setup of the 700 Series applicator can be seen above. The main harness of interest is the tractor power/communication harness (006-7651C). This harness will connect at the tractor battery, to the ISO Communication Module (ICM) mounted in the cab, a keyed power connection point, and connect at the hitch area to the baler power/communication harness (006-765B2). View below to see highlighted installation instruction:



**12V Battery Connection**

The 12V battery connection must be at the tractor battery. Connection to alternative locations such as an accessory port can cause problems with applicator system.

**\*MUST BE CONNECTED DIRECT TO TRACTOR BATTERY TERMINALS\***



**ISO Communication Module**

The ISO communication module is to be mounted inside the cab. Other mounting locations can lead to issues with weathering and operation. Once installed and the system is powered, a green light will turn on the ICM module.



**Key Power Connection**

Ensure a solid keyed connection is found inside the cab and wired into. Poor keyed power connection can result in applicator system issues.



**Harness Connection to Baler**

The tractor harness connects at the hitch to baler power/communication harness (006-765B2). This will allow the system components to communicate with one another. Ensure connections are debris and corrosion free.

## Display Options

### Optional Tablet Display

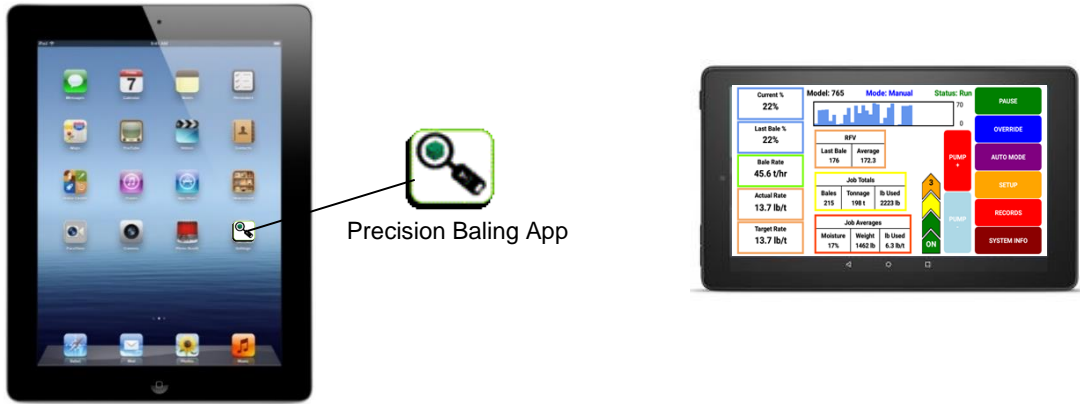

The iOS or Android Tablet displays offer the ability to communicate with the 700 series applicator system via hard-wired connection to the ISO Communication Module (ICM). Through the free Precision Baling App, the operator can set real time baling parameters to ensure the most precise application to every bale. This provides a multi-use option while utilizing the improved app to select objects, enter data, and easily switch through operational screens.

The Tablet Display offers easy integration by connecting a charging cable to the USB port on the ICM module (USB port closest to LED light). Once, connected the Harvest Tec applicator will display upon opening the app and powering up the applicator system. Tablets can be used in addition to integrated baler VT display.

**\*Made for iPad® (3<sup>rd</sup> generation minimum) or Android Tablet (Does not work with Amazon Fire). Required to be running the most current operating system or one version previous.**

\*iPad is a trademark of Apple Inc., registered in the U.S. and other countries.

### Optional Harvest Tec Display



The 700 series Harvest Tec Display will allow you to set your real time baling parameters to ensure the most precise application to every bale. This is done by utilizing the improved touch technology to select objects, enter data, and swipe through operational screens.

The Harvest Tec Display offers easy integration by connecting to the additional CAN plug on the 006-765IC harness. Once, connected the Harvest Tec display will power up with applicator system.

**Note: The Harvest Tec Display must be used as a standalone display, the baler cannot run both integrated and on the Harvest Tec Display. Must be one or the other. Removal of the 006-765VA integration harness is required when equipped.**



## Optional Baler VT Integration

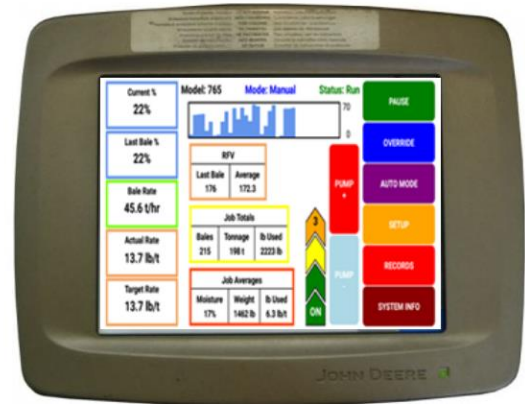
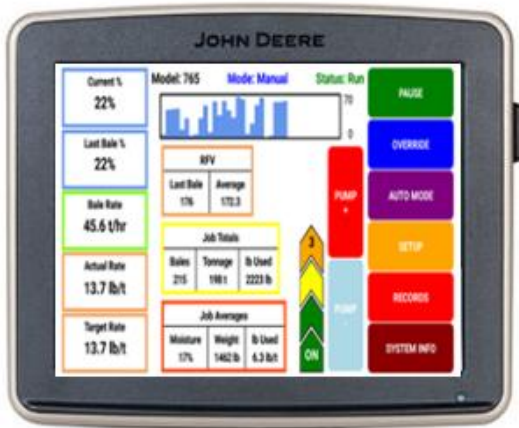

The 700 series integration to the Baler VT allows for the ability to set your real time baling through the baler VT and monitor both baler settings and Harvest Tec system parameters through one monitor to ensure the most precise application to every bale.

The 700 series offers easy integration by connecting to the additional CAN plug on the 006-765B harness. Once connected the Harvest Tec system will display with power up of the baler and applicator system.

## Baler Display Integration

The ISOBUS Monitor utilizes a combination of soft keys, touch panel, and number menus. All buttons are labeled and color coded.



## Baler Monitor Setup

Follow the instructions below to finish setup of the Harvest Tec 700J system through the John Deere ISOBUS monitors.

### 2600 Series Monitors

1. Starting from the Home Page select the Up Arrow with the dot on top.

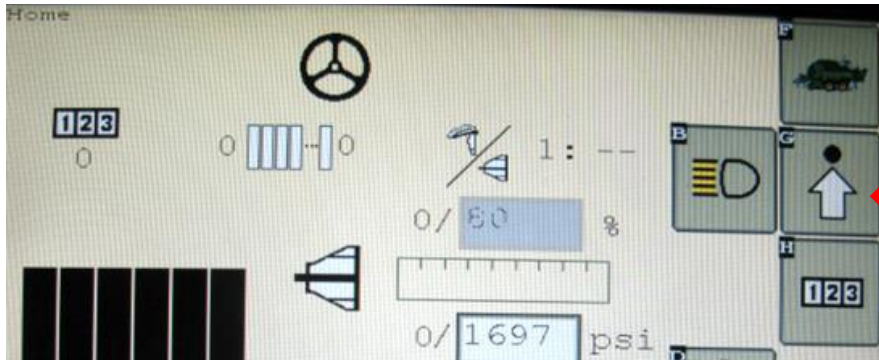

2. On the Machine Setup page that will appear, select soft key D (Page Right)

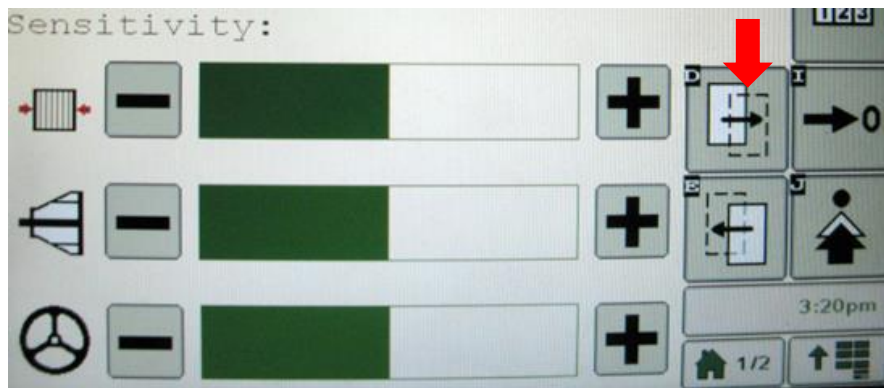

3. On the next page select the Harvest Tec option. The Check mark indicates that the system is now on.

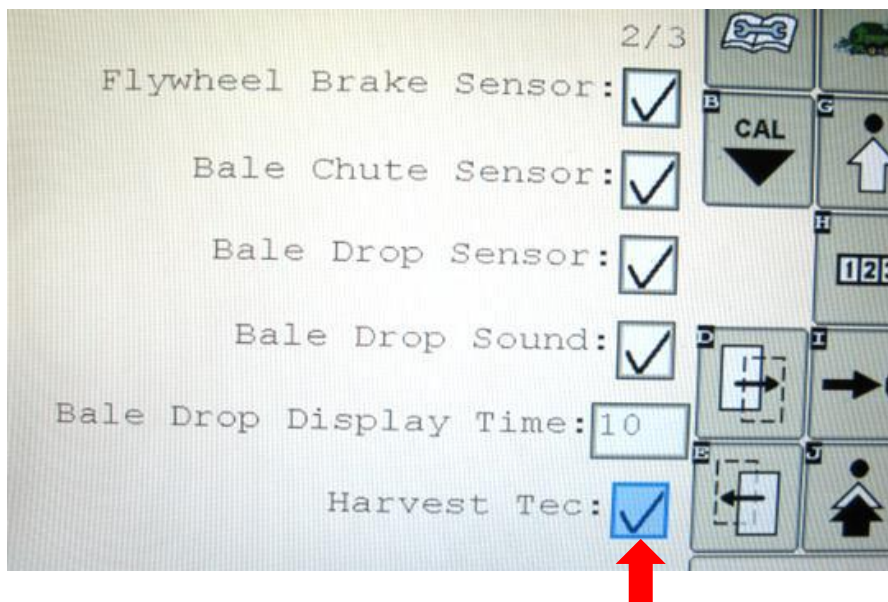

## Baler Monitor Setup (continued)

### 2600 Series Monitor Baler run Screen Details

Harvest Tec information will display on the bottom of screen in the center

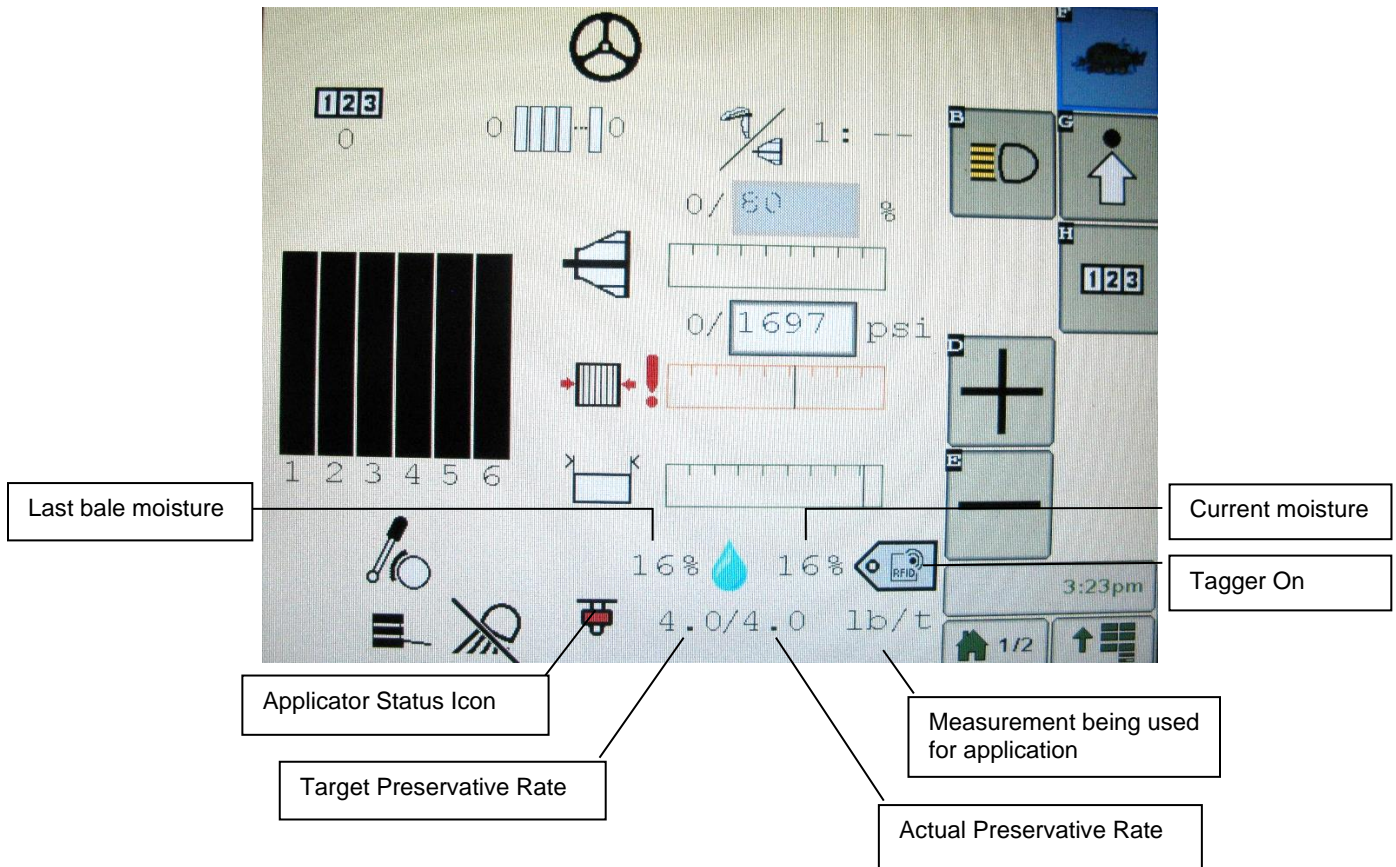

### Stats Icon Descriptions



Applicator is not in a run mode.



System is at End of Row as indicated by the Optional Hay Indicators (Crop-Eyes).



Applicator is in Automatic or Manual Mode.



System is in Pause Mode from pressing the Pause button.

# Baler Monitor Setup

## GreenStar 4<sup>th</sup> Generation Arm Command Display

Display software version **8.10.2393-23 or later**, is required on the display to ensure compatibility. Earlier versions are not all compatible. This information can be found by selecting “Menu” in the lower right-hand corner of the display, select the third tab down labeled “System”, press “Software Manager”, then the “Version Information” tab and the software versions will be displayed (Figure 1).

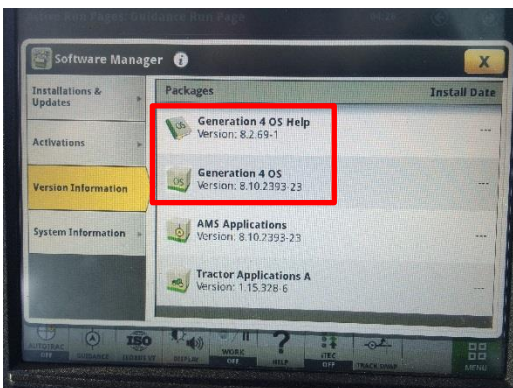

Figure 1



Figure 2

Once you have made sure the software version is at or above the recommended version, return to the tractor run screen. When on the run screen, there will be an ISO button (Figure 2) on the bottom toolbar. Pressing this will bring you into the “Connected ISOBUS Implements” page (Figure 3). If Harvest Tec is powered up correctly and active on the ISOBUS, the icon labeled “Forage, Harvest Tec, Inc.” will display. If the files are still loading you will see a loading status.

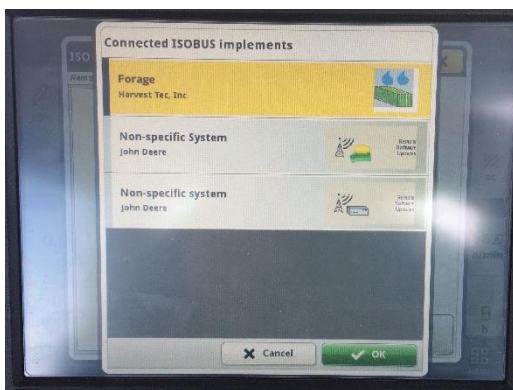

Figure 3



Figure 4

Once the files are loaded onto the display, you will receive a warning (Figure 5) to inform the operator that another device has been added onto the ISOBUS. This can be accepted and then selecting the Harvest Tec device in the ISOBUS menu will bring the Harvest Tec system.

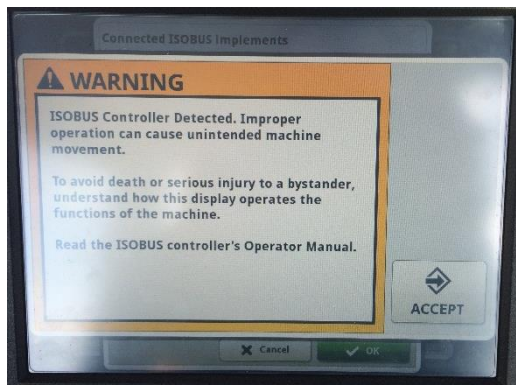

Figure 5

## Baler Monitor Setup (continued)

When the Harvest Tec system is connected you can also access the applicator by following these screens:



## Wiring Diagram – 700 Series Moisture Only

1. Connect the power harness (006-7651C) to the tractor battery (12 volt) using the red wire with fuse to the positive side and the black wire to the negative.



**A. The power harness must be connected to the battery!**

**CONTACT HARVEST TEC BEFORE MODIFICATIONS.**

*\*The unit will draw more amps than convenience outlets can handle. Any modifications of the power harness will void systems warranty\**

**B. This unit will not function on positive ground tractors.**

**C. If the unit loses power while operating it will not keep track of accumulated pounds of product used.**

2. The power harness on the tractor (006-7651C) will run from the tractor battery to the hitch. The power harness on the baler (006-765B2) will connect to the tractor power harness (006-7651C) at the hitch.
3. Connect the keyed power wire (006-765CPH) to a keyed power source on the tractor.

**The keyed power wire must connect to a keyed source or the unit will not power up correctly.**

4. Attached the ISO Communication Module (006-6673) to the tractor power harness (006-7651C).
5. Attach the End of Bale (EOB) connection on baler harness (006-765B2) to the EOB Sensor (006-7401).
6. Attach star wheel (030-4642 U/UE) connection to ISO Pump Module on pump plate assembly.

## System Wiring Diagram

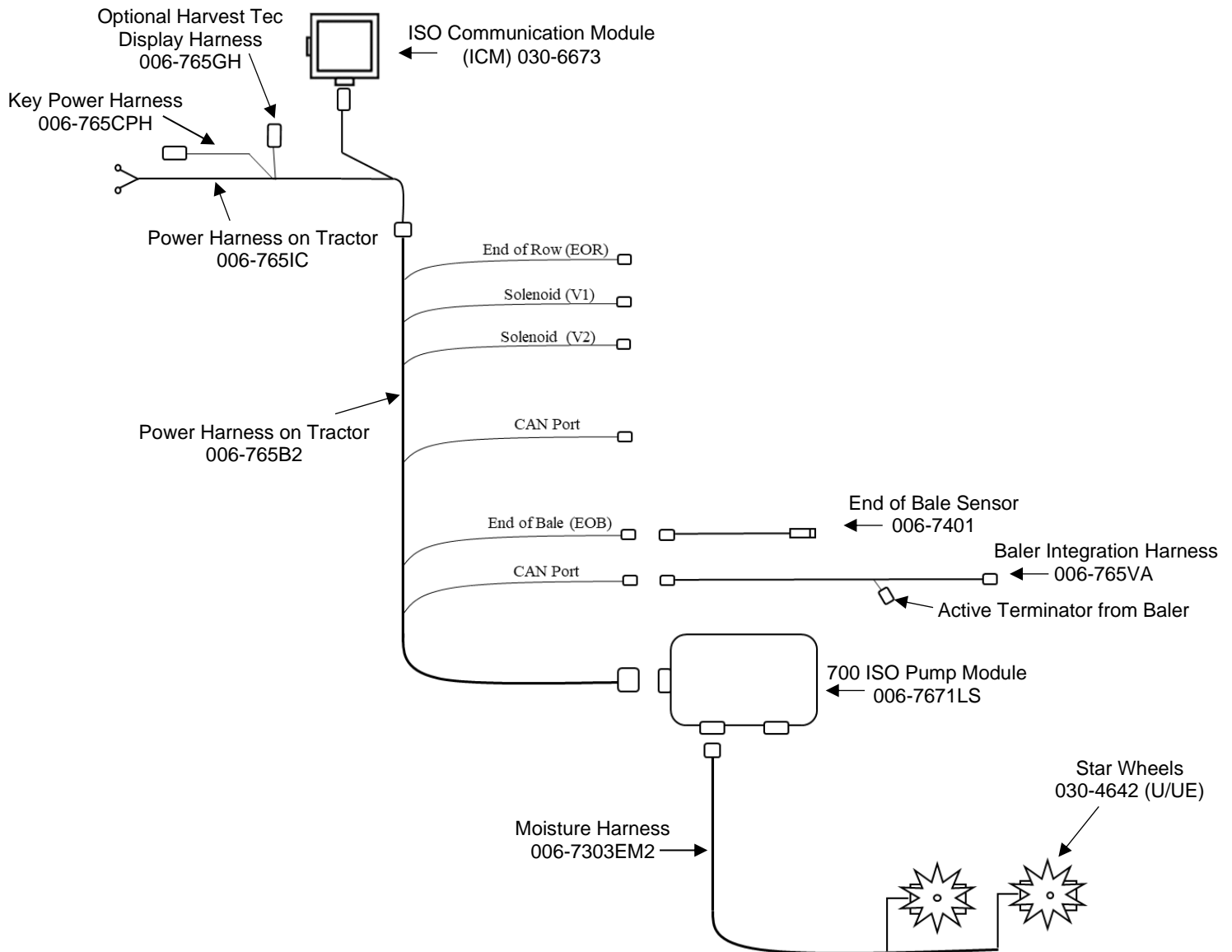

## Pin Outs

### Integrated Control Module (ICM) on harness 006-765IC

(Deutsch Plug Number: DTM06-12SA)

|        |             |                 |
|--------|-------------|-----------------|
| Pin 1  | Red         | +12V from ECU   |
| Pin 2  | Purple      | Signal Wire     |
| Pin 3  | Red/White   | +12V CAN X      |
| Pin 4  | Black/White | Ground CAN X    |
| Pin 5  | Orange      | CAN X Hi        |
| Pin 6  | Blue        | CAN X Lo        |
| Pin 7  | Green       | ISO CAN Lo      |
| Pin 8  | Yellow      | ISO CAN Hi      |
| Pin 9  | White       | GPS Expansion 1 |
| Pin 10 | Gray        | GPS Expansion 2 |
| Pin 11 | Brown       | GPS Expansion 3 |
| Pin 12 | Black       | Ground from ECU |

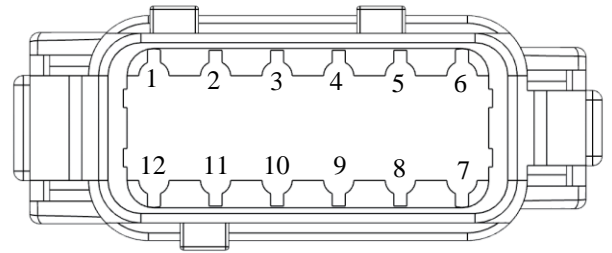

### ISOBUS Plug on harness 006-765IC

(Deutsch Plug Number: DT04-4P)

|       |        |                 |
|-------|--------|-----------------|
| Pin 1 | Red    | +12V from ECU   |
| Pin 2 | Yellow | ISO CAN Hi      |
| Pin 3 | Green  | ISO CAN Lo      |
| Pin 4 | Black  | Ground from ECU |

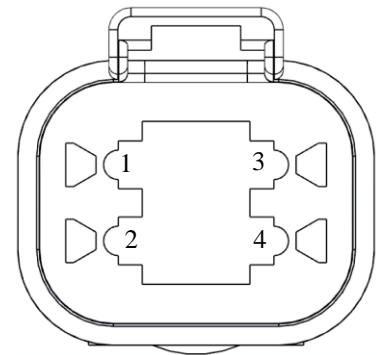

### Power / Communication Harness 006-765IC at Baler Hitch

(Deutsch Plug Number: HDP24-24-18PN)

|        |             |                     |
|--------|-------------|---------------------|
| Pin 1  | Not Used    | ----                |
| Pin 2  | Yellow      | ISO CAN Hi          |
| Pin 3  | Green       | ISO CAN Lo          |
| Pin 4  | Red         | +12V Power to ECU   |
| Pin 5  | Black       | Ground to ECU       |
| Pin 6  | Red         | +12V From Battery   |
| Pin 7  | Not Used    | ----                |
| Pin 8  | Black       | Ground From Battery |
| Pin 9  | Not Used    | ----                |
| Pin 10 | Purple      | Signal Wire         |
| Pin 11 | Red/White   | +12V CAN X          |
| Pin 12 | Black/White | Ground CAN X        |
| Pin 13 | Orange      | CAN X Hi            |
| Pin 14 | Blue        | CAN X Lo            |
| Pin 15 | White       | GPS Expansion 1     |
| Pin 16 | Gray        | GPS Expansion 2     |
| Pin 17 | Brown       | GPS Expansion 3     |
| Pin 18 | Not Used    | ----                |

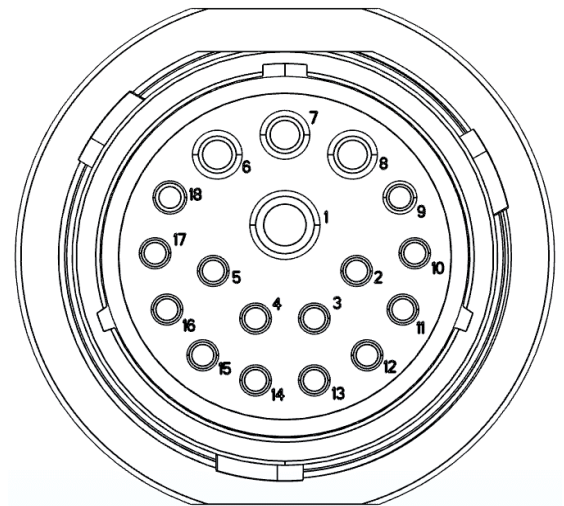

## Pin Outs (continued)

### Power / Communication Harness 006-765B2 at Baler Hitch IPM

(Deutsch Plug Number: HDP26-24-18SN)

|        |              |                     |
|--------|--------------|---------------------|
| Pin 1  | Not Used     | ----                |
| Pin 2  | Yellow       | ISO CAN Hi          |
| Pin 3  | Green        | ISO CAN Lo          |
| Pin 4  | Red          | +12V Power to ECU   |
| Pin 5  | Black        | Ground to ECU       |
| Pin 6  | Red          | +12V From Battery   |
| Pin 7  | Not Used     | ----                |
| Pin 8  | Black        | Ground From Battery |
| Pin 9  | Not Used     | ----                |
| Pin 10 | Orange/White | +12V Power to EOR   |
| Pin 11 | Not Used     | ----                |
| Pin 12 | Not Used     | ----                |
| Pin 13 | Not Used     | ----                |
| Pin 14 | Not Used     | ----                |
| Pin 15 | Not Used     | ----                |
| Pin 16 | Not Used     | ----                |
| Pin 17 | Not Used     | ----                |
| Pin 18 | Not Used     | ----                |

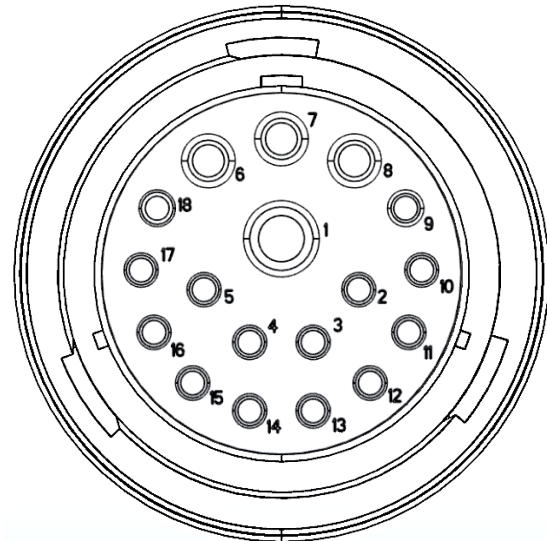

### Power / Communication Harness 006-765B2 at IPM Module

(Deutsch Plug Number: HDP24-24-18SN)

|        |              |                          |
|--------|--------------|--------------------------|
| Pin 1  | Not Used     | ----                     |
| Pin 2  | Yellow       | ISO CAN Hi               |
| Pin 3  | Green        | ISO CAN Lo               |
| Pin 4  | Red          | +12V Power to ECU        |
| Pin 5  | Black        | Ground to ECU            |
| Pin 6  | Red          | +12V From Battery        |
| Pin 7  | Not Used     | ----                     |
| Pin 8  | Black        | Ground From Battery      |
| Pin 9  | Not Used     | ----                     |
| Pin 10 | Orange/White | +12V Power to EOR        |
| Pin 11 | Orange/Black | Ground to EOR            |
| Pin 12 | Purple/Green | EOR Signal               |
| Pin 13 | Blue/White   | EOB Signal               |
| Pin 14 | Gray/Red     | +12V Power to Solenoid 1 |
| Pin 15 | White/Black  | Ground to Solenoid 1     |
| Pin 16 | Orange/Red   | +12V Power to Solenoid 2 |
| Pin 17 | White/Black  | Ground to Solenoid 2     |
| Pin 18 | Not Used     | ----                     |

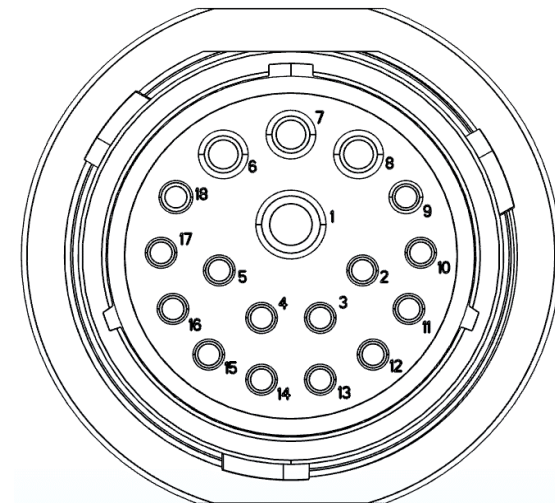

\*IPM Module Whip Plug- Pin # 5 Not Used

### Solenoid 1 Plug on Baler Harness 006-765B

(Deutsch Plug Number: APTIV 12052641)

|       |             |                      |
|-------|-------------|----------------------|
| Pin B | Gray/Red    | +12V to Solenoid 1   |
| Pin A | White/Black | Ground to Solenoid 1 |

### Solenoid 2 Plug on Baler Harness 006-765B

(Deutsch Plug Number: APTIV 12052641)

|       |             |                      |
|-------|-------------|----------------------|
| Pin B | Orange/Red  | +12V to Solenoid 2   |
| Pin A | White/Black | Ground to Solenoid 2 |

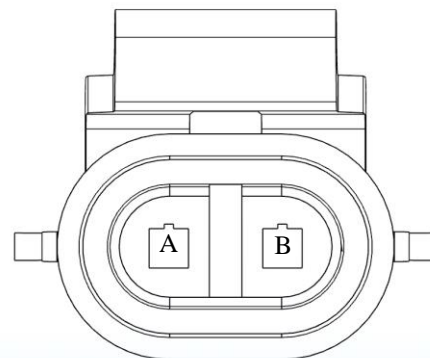



## Pin Outs (continued)

### CAN / IDM on Baler Harness 006-765B

(Deutsch Plug Number: DT06-4S)

|       |        |               |
|-------|--------|---------------|
| Pin 1 | Red    | +12V to ECU   |
| Pin 2 | Yellow | ISO CAN Hi    |
| Pin 3 | Green  | ISO CAN Lo    |
| Pin 4 | Black  | Ground to ECU |

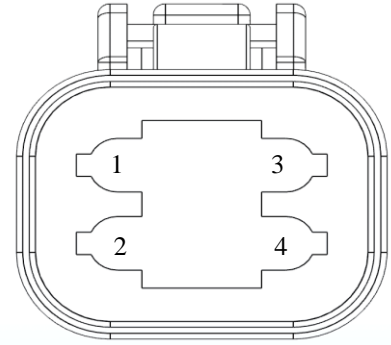

### End of Bale Sensor Plug on Baler Harness 006-765B

(Deutsch Plug Number: DT06-3S)

|       |              |                               |
|-------|--------------|-------------------------------|
| Pin 1 | Orange/White | +12V to End of Bale Sensors   |
| Pin 2 | Orange/Black | Ground to End of Bale Sensors |
| Pin 3 | Blue/White   | Signal                        |

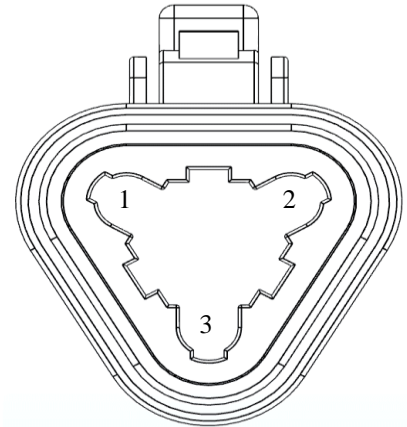

### End of Row Sensors Plug on Baler Harness 006-765B

(Deutsch Plug Number: DT06-3S)

|       |              |                               |
|-------|--------------|-------------------------------|
| Pin 1 | Orange/White | +12V to End of Bale Sensors   |
| Pin 2 | Orange/Black | Ground to End of Bale Sensors |
| Pin 3 | Blue/White   | Signal                        |

### Integration Harness Plug on Baler Harness 006-765VA

(Plug: APTIV 12052848)

|       |          |            |
|-------|----------|------------|
| Pin A | Not Used | ----       |
| Pin B | Red      | TBC Power  |
| Pin C | Not Used | ----       |
| Pin D | Gray     | TBC Ground |
| Pin E | Orange   | CAN Hi     |
| Pin F | Blue     | CAN Lo     |

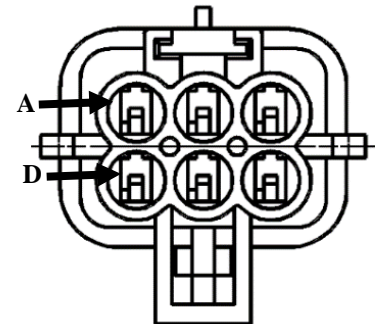

### Pump Connection on 700 Controller Harness

(16 AWG Two-Wire Plug)

|       |       |                |
|-------|-------|----------------|
| Pin 1 | Red   | Power to Pump  |
| Pin 2 | Black | Ground to Pump |

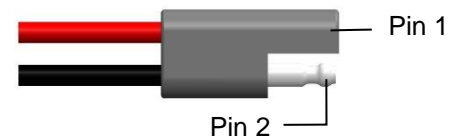

## Star Wheel Sensors

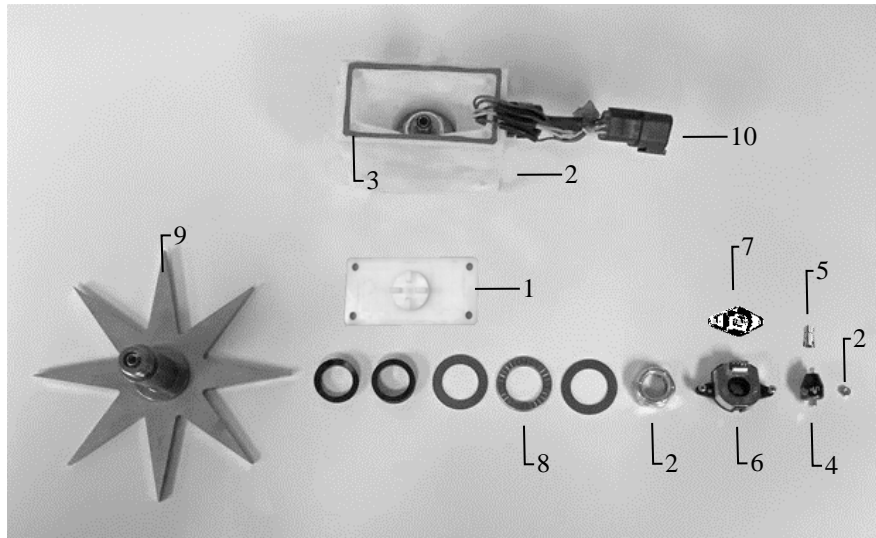

| <u>Ref</u>    | <u>Description</u>                   | <u>Part#</u> | <u>Qty</u> |
|---------------|--------------------------------------|--------------|------------|
| 1             | Block Cover                          | 006-4642UC   | 1          |
| 2             | Star Wheel Block                     | 006-4642UB   | 1          |
| 3             | Star Wheel Gasket                    | 006-4642UG   | 1          |
| 4             | Electric Swivel                      | 006-4642A    | 1          |
| 5             | Swivel Insert                        | 006-4642B    | 1          |
| 6             | Encoder                              | 006-4512E    | 1          |
| 7             | Encoder Mount                        | 006-4512P    | 1          |
| 8             | Washers                              | 006-4642K    | 1          |
| 9             | Star Wheel                           | 006-4642US   | 1          |
| 10            | Encoder Harness (6 pin)              | 006-7307EM   | 1          |
| NP            | Moisture Harness (2 pin)             | 006-7307M    | 1          |
| 1-10          | Star wheel assembly<br>(w/ Encoder)  | 030-4642UE   | 1          |
| 1-5<br>8,9,NP | Star wheel assembly<br>(w/o Encoder) | 030-4642U    | 1          |



## Moisture Harness

| <u>Ref</u> | <u>Description</u> | <u>Part #</u> | <u>Qty</u> |
|------------|--------------------|---------------|------------|
| 11         | Moisture Harness   | 006-7307EM2   | 1          |

## Control Box and Wiring Harnesses



| <u>Ref</u> | <u>Description</u>       | <u>Part#</u> | <u>Qty</u> | <u>Ref</u> | <u>Description</u>        | <u>Part#</u> | <u>Qty</u> |
|------------|--------------------------|--------------|------------|------------|---------------------------|--------------|------------|
| 1          | Power Lead Baler 20'     | 006-765B2    | 1          | NP         | Baler Integration Harness | 006-765VA    | 1          |
| 2          | Power lead tractor       | 006-7651C    | 1          | NP         | Dust Plug Kit             | 006-765DP    | 1          |
| 3          | Key Switch Wire          | 006-765CPH   | 1          |            |                           |              |            |
| 4          | ISO Pump Module          | 006-7671LS   | 1          |            |                           |              |            |
| 5          | ISO Communication Module | 006-6673     | 1          |            |                           |              |            |

## End of Bale Sensor Kit

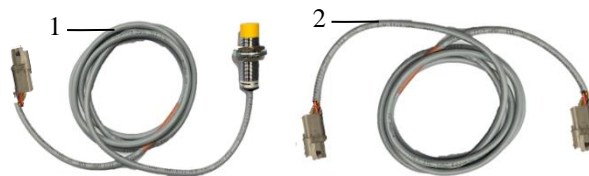

| <u>Ref</u> | <u>Description</u> | <u>Part #</u> | <u>Qty</u> |
|------------|--------------------|---------------|------------|
| 1          | End of Bale Sensor | 006-7401      | 1          |
| 2          | End of Bale Ext.   | 006-7401EXT   | 1          |
|            | Complete Assembly  | EOB-LS-STD    |            |

## **Harvest Tec Inc. Warranty and Liability Agreement**

Harvest Tec, Inc. will repair or replace components that are found to be defective within 12 months from the date of manufacture. Under no circumstances does this warranty cover any components which in the opinion of Harvest Tec, Inc. have been subjected to negligent use, misuse, alteration, accident, or if repairs have been made with parts other than those manufactured and obtainable from Harvest Tec, Inc.

Our obligation under this warranty is limited to repairing or replacing free of charge to the original purchaser any part that in our judgment shows evidence of defective or improper workmanship, provided the part is returned to Harvest Tec, Inc. within 30 days of the failure. If it is determined that a non-Harvest Tec branded hay preservative has been used inside the Harvest Tec applicator system where the failure occurred, then Harvest Tec reserves the right to deny the warranty request at their discretion. Parts must be returned through the selling dealer and distributor, transportation charges prepaid.

This warranty shall not be interpreted to render Harvest Tec, Inc. liable for injury or damages of any kind, direct, consequential, or contingent, to persons or property. Furthermore, this warranty does not extend to loss of crop, losses caused by delays or any expense prospective profits or for any other reason. Harvest Tec, Inc. shall not be liable for any recovery greater in amount than the cost or repair of defects in workmanship.

There are no warranties, either expressed or implied, of merchantability or fitness for particular purpose intended or fitness for any other reason.

This warranty cannot guarantee that existing conditions beyond the control of Harvest Tec, Inc. will not affect our ability to obtain materials or manufacture necessary replacement parts.

Harvest Tec, Inc. reserves the right to make design changes, improve design, or change specifications, at any time without any contingent obligation to purchasers of machines and parts previously sold.

Revised 4/17

**HARVEST TEC, INC.**  
**P.O. BOX 63**  
**2821 HARVEY STREET**  
**HUDSON, WI 54016**  
**PHONE: 715-386-9100**  
**1-800-635-7468**  
**FAX: 715-381-1792**