

Installation Manual

Model 796BB ***115 Gallon Preservative Applicator***



P.O. Box 63 • 2821 Harvey Street • Hudson, WI 54016
800-635-7468 • www.harvesttec.com

DECLARATION OF INCORPORATION



MANUFACTURER: Harvest Tec LLC.
2821 Harvey St.
P.O. Box 63
Hudson, WI 54016, U.S.A.

REPRESENTATIVE ESTABLISHED IN COMMUNITY: Profitable Farming Company
Middle Barlington, Roborough
Winkleigh, Devon, EX19 8AG
ENGLAND

The person above certifies and declares that:

VIRTUAL MACHINE: Equipment mounted on a farm press and for the application of inoculants onto forage crops.

MODEL: 796BB-INST-21-Imp&Metric

BRAND: Harvest Tec

SERIAL NUMBER:

This application preservatives for hay Harvest Tec system meets the Directive 2006/42/EC of the European Parliament and the Council of 17 May 2006 and other applicable European Directives including Directive 2004/108/EC on the Electromagnetic compatibility.

The application of preservatives for hay Harvest Tec system will be turned on after being installed on a farm press has been declared in conformity with the Machinery Directive.

Person in the community authorized to provide information on the partly completed machinery and making this statement:

Richard Snell, President, Profitable Farming Company

Signed on May 21, 2011: Middle Barlington, Roborough
Winkleigh, Devon, EX19 8AG
ENGLAND

Table of Contents

	<u>Page</u>
Introduction	4-5
System Overview	5
Installation of Applicator	6-17
Installation of Tank	6-7
Installation of Pump Plate	8
Installation of Drain/Fill Line	9
Installation of Spray Shield	10-11
Installation Kit 4532C, 4533C, & 4534C	10
Installation Kit 4535C & 4536C	11
Wind Guard Installation	12-13
Mounting Solenoids and Hose Routing	14
Main Wire Harness and Baler Interface Harness Routing	15
Installation of Star Wheels	16
Installation End of Bale Sensor	17
Tractor Setup	18
Display Installations	19-29
Harvest Tec Display	19
Tablet Display	19
Baler Display	20-29
Wiring Diagram	30
Pin Outs	31-33
Parts Breakdown	34-42
Tank, Saddle and Saddle Legs	34
Pump Manifold	35
Star Wheel Moisture Sensor	36
Control Boxes and Wiring Harnesses	37
Solenoid Package	38
Hose and Drain / Fill Line	39
Optional iPad Mini Mounting Kit	40
Optional iPad Display Kit	41
Optional Harvest Tec Display Kit	42
Install Kits	43-47
4532C Install Kit	43
4533C Install Kit	44
4534C Install Kit	45
4535C Install Kit	46
4536C Install Kit	47
Notes	48-50

Introduction

Thank you for purchasing the 700 series hay preservative applicator system. This applicator system has been designed to be operated through the Harvest Tec display, an Apple iPad (not included) using the Precision Baling App, or to plug directly into the baler's ISOBUS and display.

The 700 Series Preservative Applicator System is designed to apply buffered propionic acid to the forage crop as it is baled. Failure to follow instructions can result in personal injury or equipment malfunction. If you need parts for the system, please view the Parts Breakdown toward the back of this manual and contact your local authorized dealer to order the parts. This applicator is designed to apply CropSaver or ThirtyPlus buffered propionic acid.

Right and Left sides are determined by facing in the direction of forward travel.

System Requirements



CNH Baler Monitor must have version 4.2.0 or higher



Made for Harvest Tec Display, Baler Integration, or Tablet
For best performance ensure all displays are running the latest operating system.

System Overview

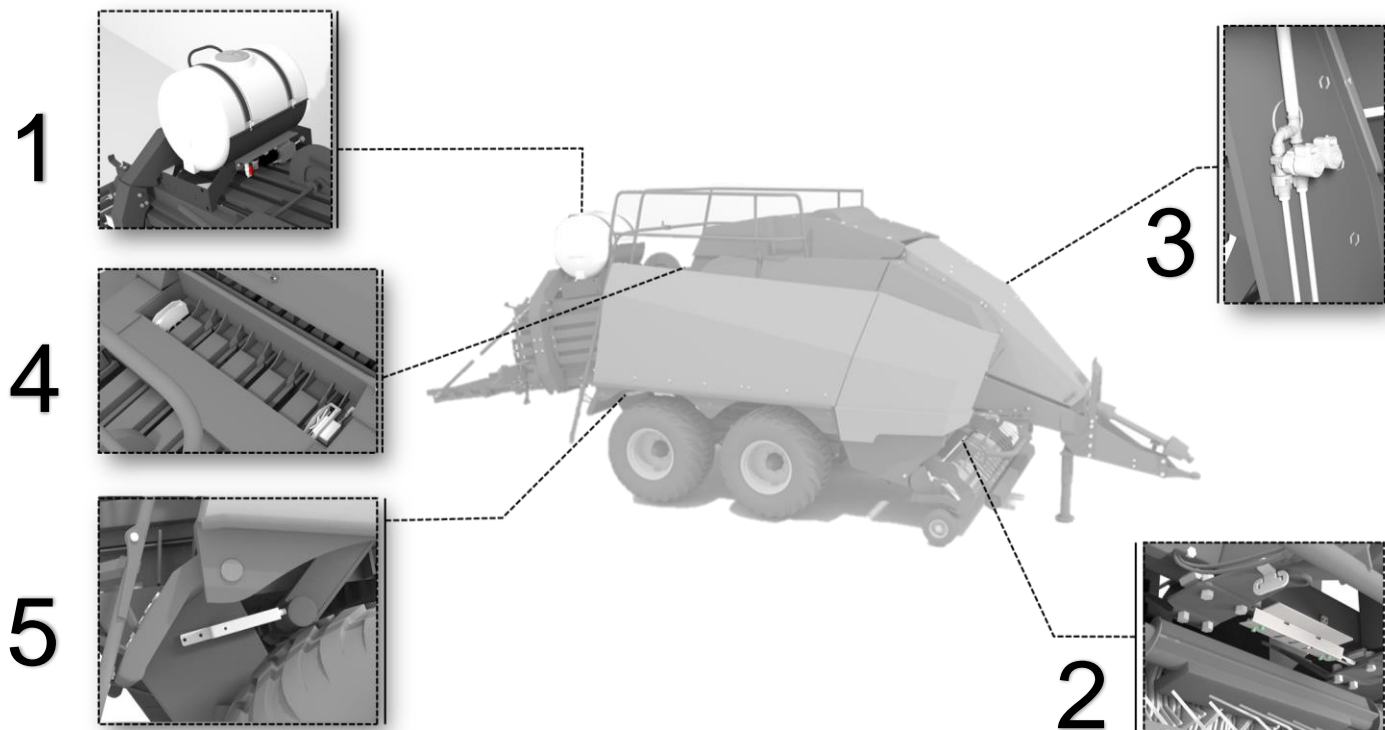

The 700 series applicator system consists of five main areas of installation, these include:

- 1) Tank Mounting Installation
- 2) Spray Shield Installation
- 3) Solenoid Installation
- 4) Star Wheel Installation
- 5) End of Bale Installation

Tank Installation and Pump Plate

This will mount on the bale chute towards the rear of the baler. All mounting and parts should be verified prior to beginning installation. Follow *Installation of Pump Manifold and Saddle* section for step-by-step instruction.

Spray Shield Installation

The spray shield assembly is designed to spray the hay evenly as the baler picks it up. This holds the tips and is connected to plumbing to apply preservative as precisely as possible. Follow the *Spray Shield Installation* section for sketches of the spray shield nozzle holders and step-by-step instruction.

Solenoid Installation

The dual solenoid setup is to be mounted as close to the spray shield as possible. This will provide the best result to ensure the proper output of preservative is applied through the nozzles. View *Spray Shield installation* section for instructions of solenoid mounting.

Star Wheel Installation

This is the moisture setup for the applicator system, installation will be done on top of the bale chamber so the star wheels can make sufficient contact with the bale. Follow *Star Wheel Mounting* sections for step-by-step instruction.

End of Bale Installation

The end of bale sensor determines the position of the needles on the baler. When the needles cycle the sensor communicates this information to the 700 series. Installation of this sensor is required for use with the Harvest Tec Virtual Terminal. Follow *End of Bale Sensor Installation* section for step-by-step guide.

Installation of Applicator

Attach Tank Saddle

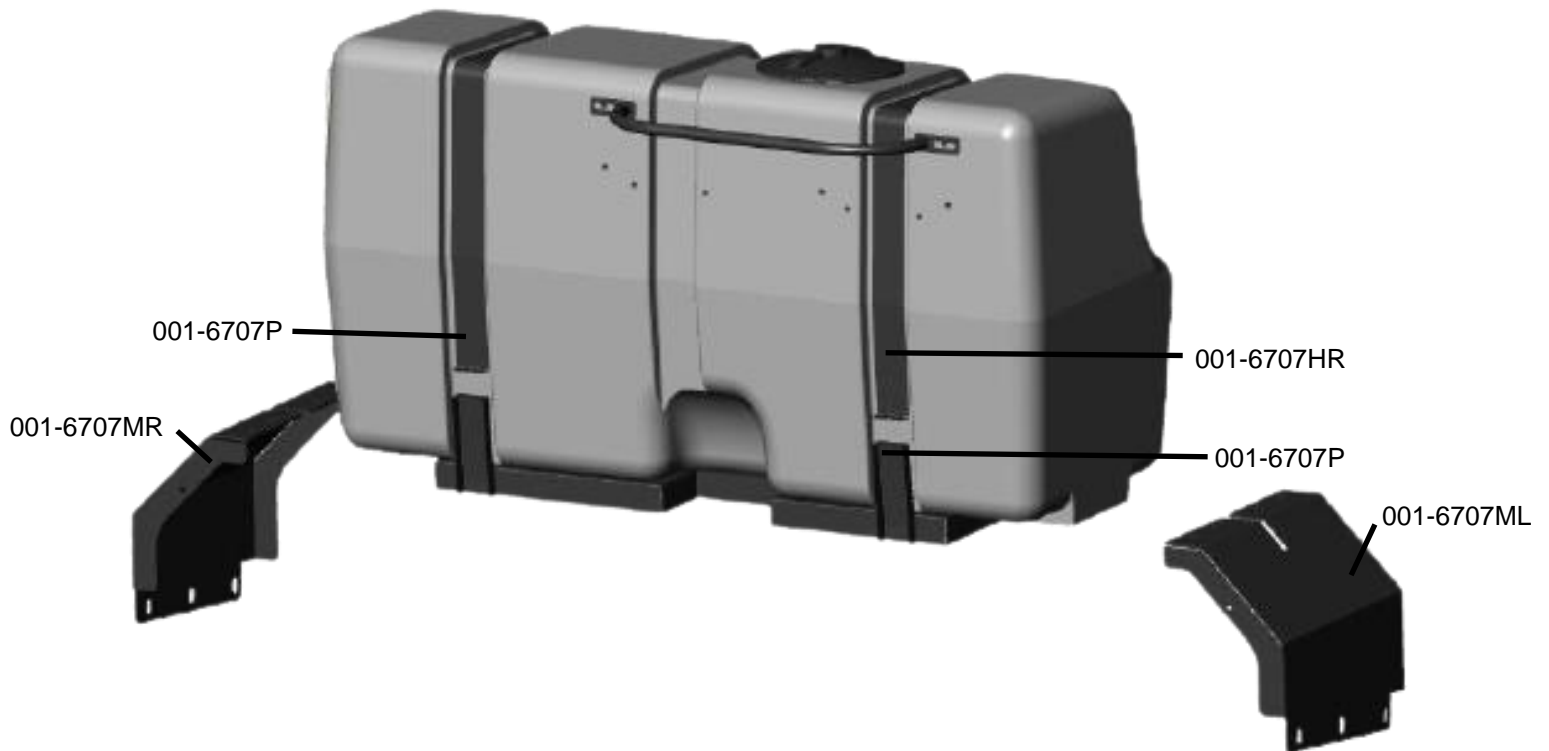

1. Remove the two tank straps (001-6707P) by removing all eight 3/8" hex nuts.
2. Lift the tank (005-9218) away from the saddle (001-6707N) and place the tank on a smooth flat surface.
3. Install the pump supply elbow (003-EL3412) on the bottom of the tank.
4. Install the drain/fill elbow (003-EL3434) on the side of the tank below the sight gauge.

Attach Tank Saddle

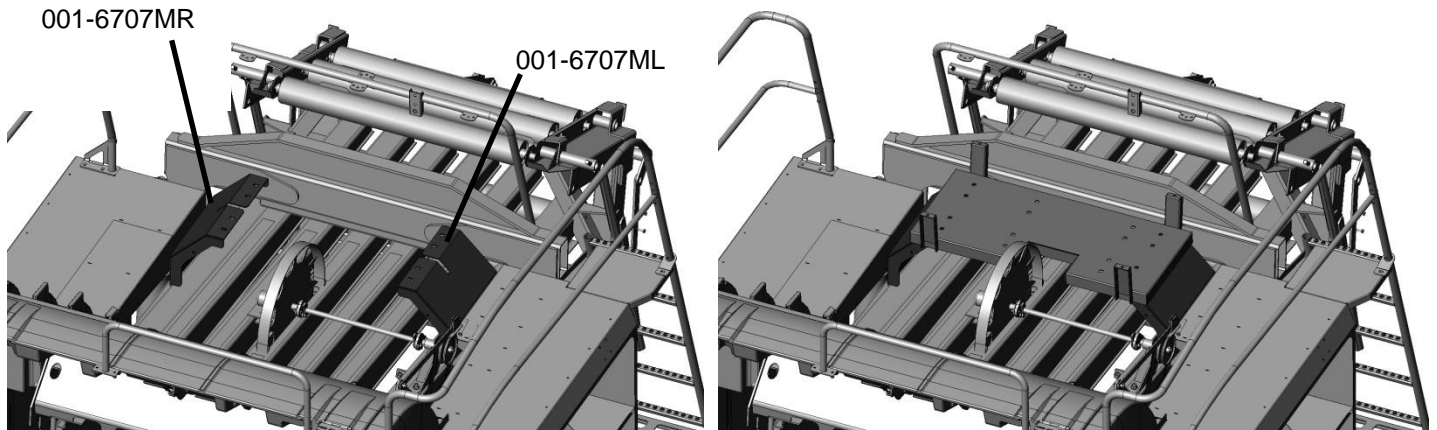

1. Install the two saddle legs (001-6707MR & 001-6707ML) on to the top of the baler chute as shown.
2. Secure the two legs with six (three per side) 1/2" x 1-3/4" carriage bolts, flats washers, locks washers, and hex nuts. The six holes will be already punched out of the baler frame and will line up with the saddle legs. Make sure the bolt head is in the chamber.
3. Install the tank saddle (001-6707N) on top of the saddle legs.
4. Secure the tank saddle to the saddle legs using eight (four per side) 1/2" x 1-3/4" carriage bolts, flat washers, lock washers, and hex nuts. Use the outside set of holes for four-foot-wide balers and the inside set of holes for three-foot-wide balers.
5. Make sure the carriage bolt heads are on top of the saddle and the bolt points towards the bale chamber.
6. Install the tank and secure with the straps and hardware removed from before. The tank straps will need to be secured with a double nut.

New Holland 330+ & Case IH LB334XL Balers

The tank leg mounting location will need to be moved toward the back of the bale chute with baler models NH330+ and Case LB334XL. Move the location back of the baler 6" (151.5mm) and drill extra hole (below)

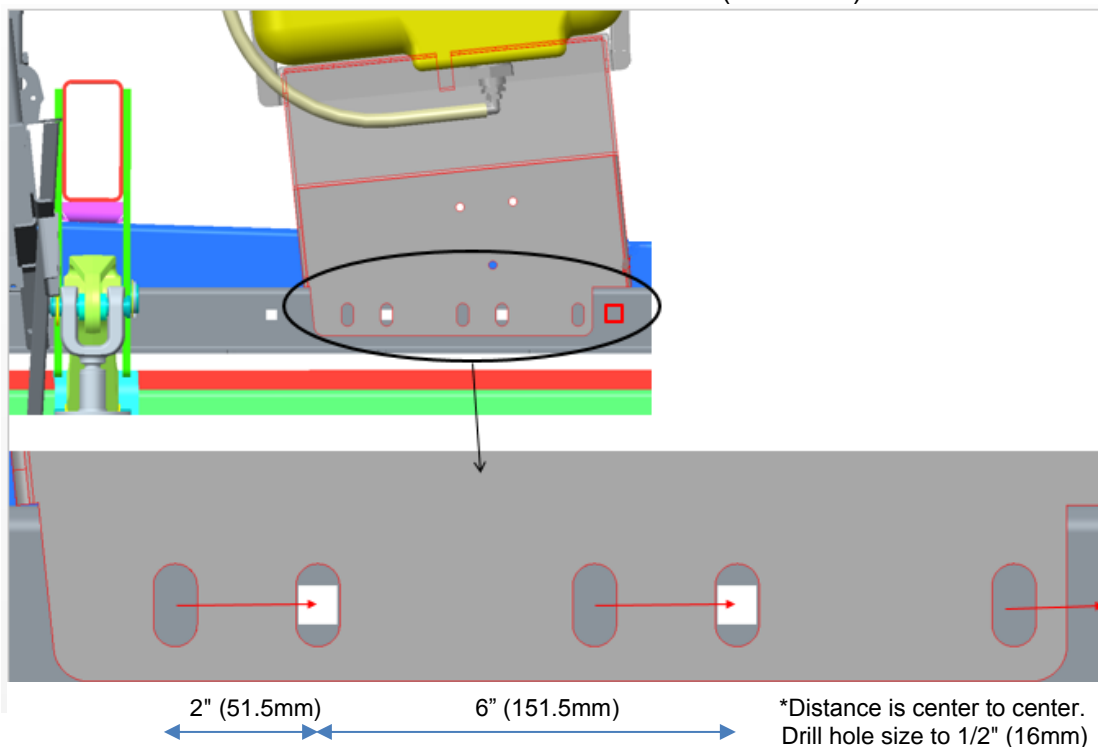

Installation of Pump Plate and Hand Rail

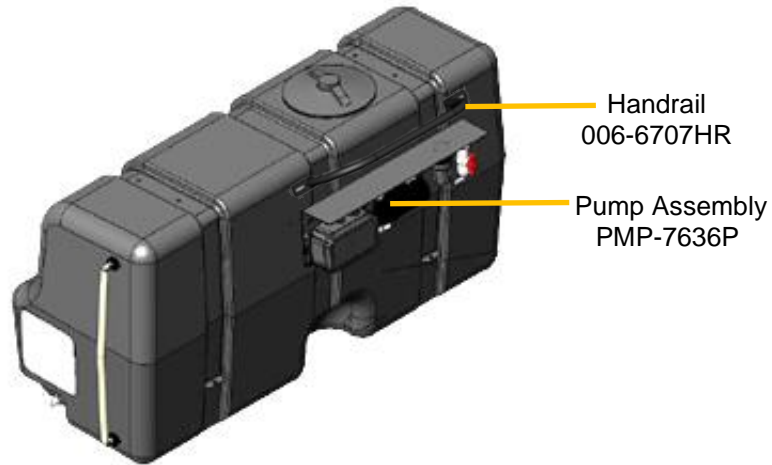

1. Attach handrail (001-6707HR) to tank with two 3/8" x 3/4" flange bolts.
2. Locate pump control (006-7671LS) and attached to pump plate with #10 x 3/4" flat head machine screws. Choose fittings and install them into valve and pump discharge.
3. Attach pump plate holder (001-4648XB) to tank and just below handrail with two 3/8" x 3/4" flange bolts.
4. Attach pump plate to the pump holder with 3/8" hardware.
5. Connect 1/2" hose between elbow fitting on bottom of tank and valve on pump plate. Secure with supplied hose clamps.

The Pump Controller and pump heads must be pointing down. Failure to mount the pump plate assembly in this specified direction will void all warranty of the Pump Controller and pumps

Optional Rear Light Camera Brackets (not included)

There is now an optional rear light extension bracket available for the NH330+ & NH340+ and LB334XL & 434XL baler models. To reposition the lights, camera, and beacon light to the back of the preservative tank.

Install the camera/light bracket (001-6707PM) as shown on the right by lining up two holes in the arms of the bracket with the holes on the tank straps. Using the supplied elevator bolts install the bolt with the head on the tank side with threads pointing upward.

Install the camera mounting brackets (001-6707PMZ) to the camera light bracket as shown on right. Move the lights and camera as needed using the light extension harness (006-7303LTX).

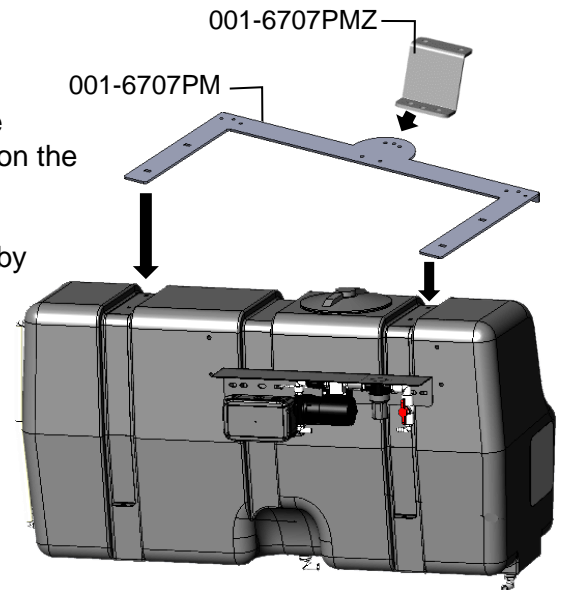

Note:

The straps will need to be loosened to allow room for placement of the bolts. Retighten after bolts are installed.

Installation of the Drain & Fill Line

1. Thread 3/4" elbow fitting into end of tank.
2. Run hose from the elbow down the frame to the bottom of the baler.
3. Drill 1/4" (7mm) holes to accept the valve holder bracket and use 5/16" x 1" self-tapping screws.
4. Connect valve assembly to other end of hose. Place hose clamps on both ends.
5. Secure hose to frame using cable locks.

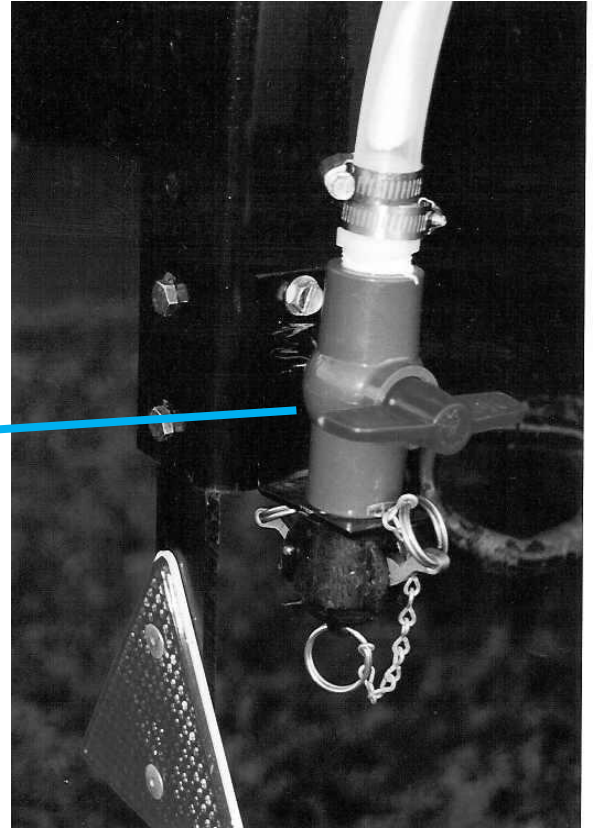

Installation of the Spray Shield

The spray shield assembly is designed to spray the hay evenly as the baler picks it up. A sketch of the spray shield nozzle holder and installation instructions are shown below.

Installation Kit 4532C, 4533C & 4534C

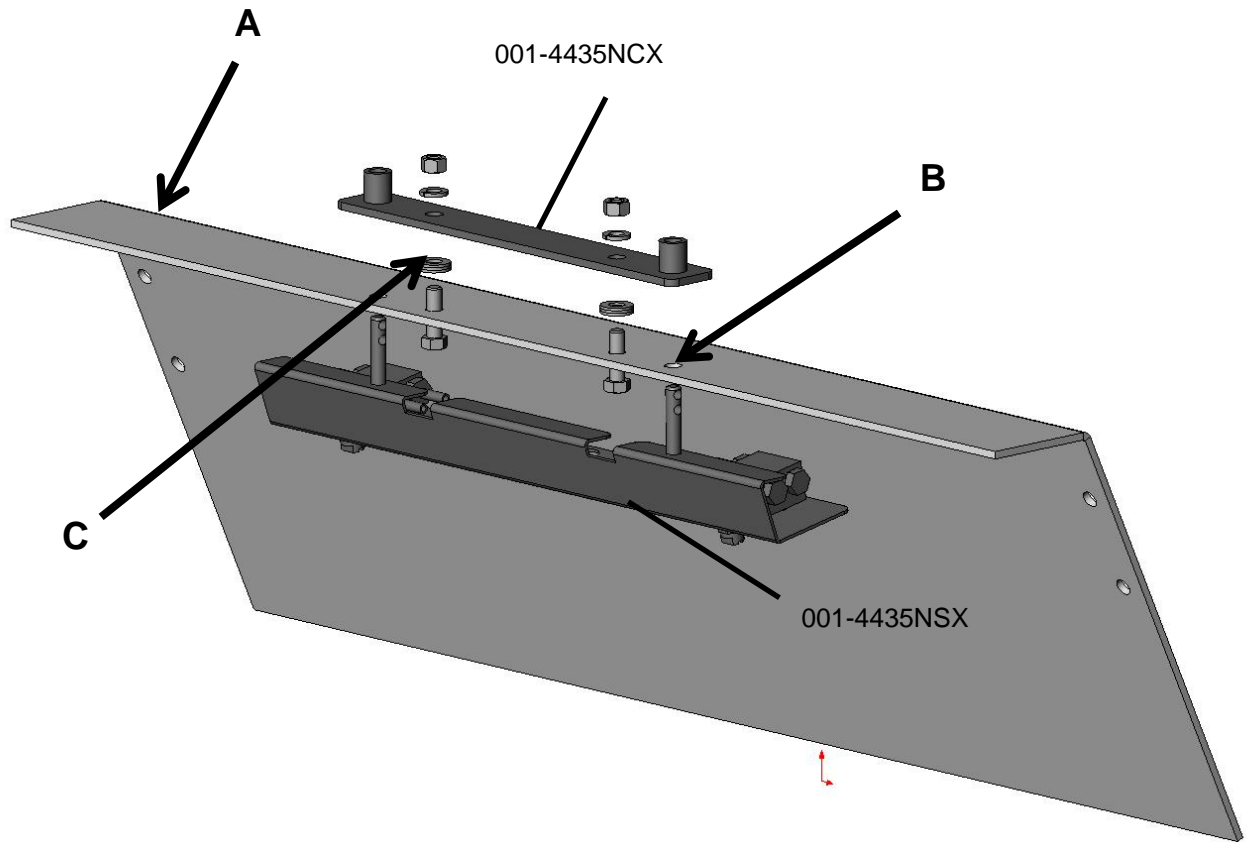

1. Locate the flat steel directly above the stuffer forks. **(A)**
2. Align the spray shield holder (001-4435NCX) to the center of the flat steel.
3. Using the shield holder (001-4435NCX) as a template clamp the holder to the baler, mark the four holes and drill them to $7/16$ " (9mm) diameter. **(B)**
4. Attach the shield holder (001-4435NCX) to the baler through the two center holes using the two $3/8$ " x $1-1/4$ " hex bolts, six flat washers, two lock washers, and two hex nuts. Six washers (three per side) may need to go between the baler and the spray shield holder. **(C)**
5. Install the spray shield (001-4435NSX) to the holder and secure by using two lynch pins. Remove washers if necessary but allow for a tight fit. **(C)**

Installation Kit 4535C & 4536C

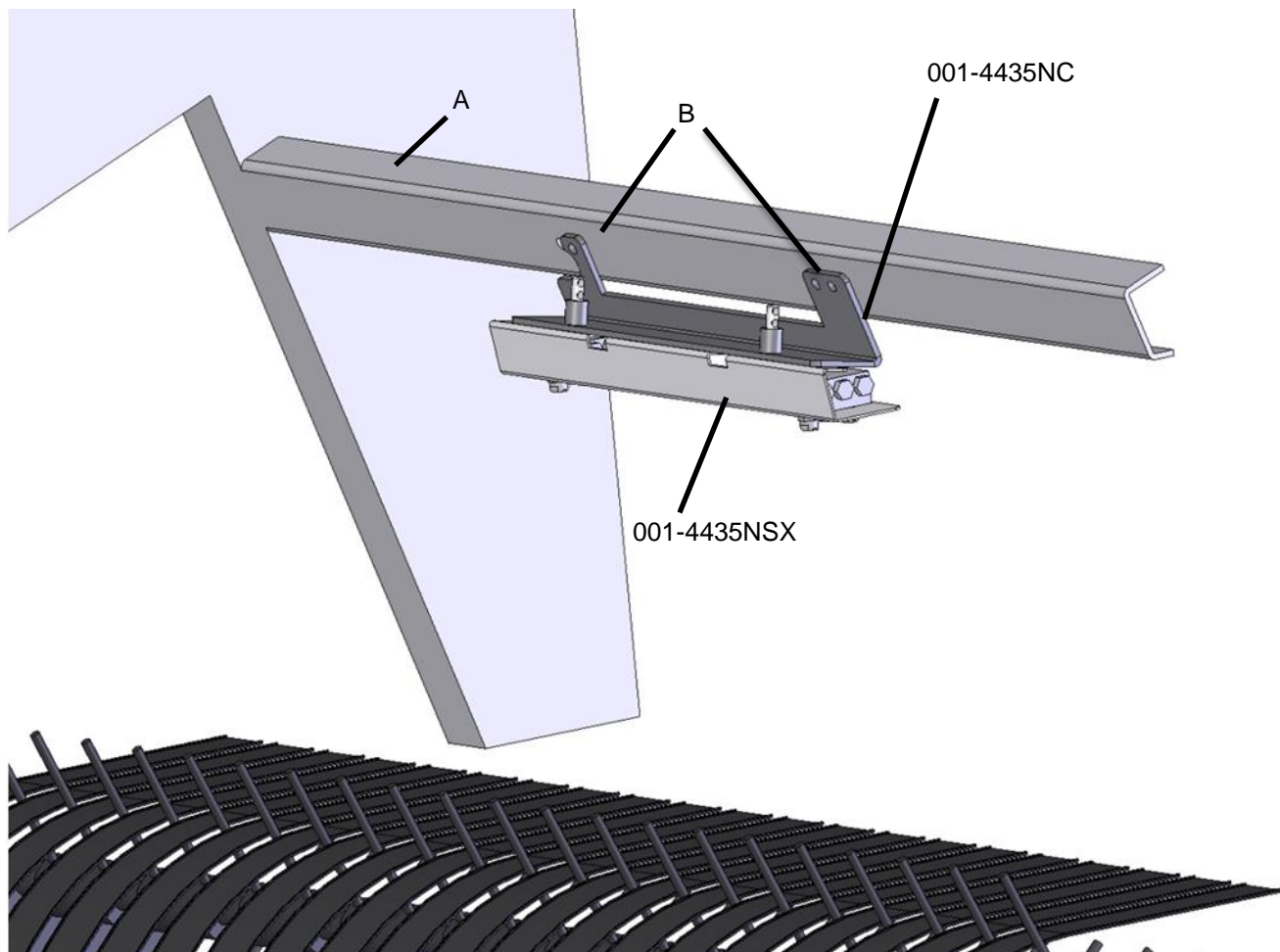

1. Locate the baler cross member directly above the rotor. **(A)**
2. Locate the four pre-drilled holes on the cross member. **(B)**
3. Install spray shield holder (001-4435NC) to baler using three 5/16" x 1" bolts, lock washers, hex nuts.
4. Install the spray shield (001-4435NSX) to the the shield holder (001-4435NC) and secure with supplied lynch pins.

Wind Guard Installation

3x3 Baler (Install Kit 4535C)

Step 1: Locate the factory drilled holes on both sides of the baler tongue. The general location of these holes is shown in the image to the right. If holes are not present or a different location is desired, drill appropriately.

Step 2: Assemble the wind guard (030-6707WG3). Start by locating all materials listed previously. Next, align the 1/4" (6mm) holes of the guard material (001-6707GM3) with the 1/4" (6mm) holes of the 001-6707MER/MEL brackets.

(It is recommended to place the guard material on top of the brackets). Next align a 001-6707MF backing plate with the 1/4" (6mm) holes on each end of the assembly. *(The rubber guard material should now be sandwiched between the mounting bracket and backing plate).* Finally, fasten together with the 1/4" hardware provided.

Step 3: Bring the assembled wind guard to the baler. Using the 5/16" hardware, fasten the wind guard to baler using the outside holes of the brackets & the holes located or drilled from Step 1.

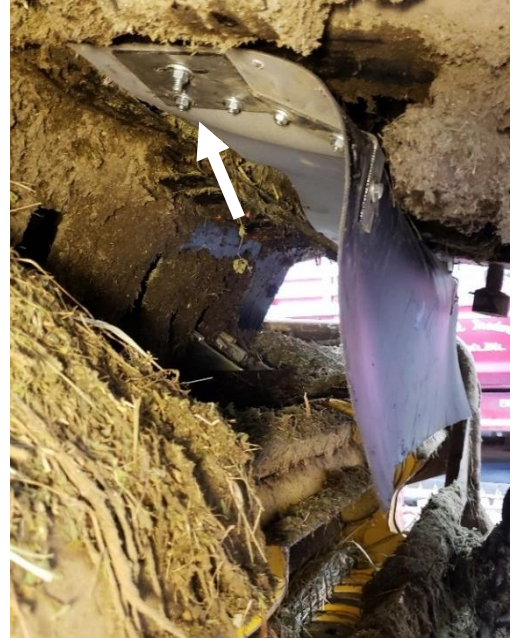

Note: If installed correctly, the wind guard should not contact the fly wheel or center feed roll when the pick-up head is fully lifted.

Complete Wind Guard Kit Part Number: 030-6707WG3

3x4 Baler (Install Kit 4536C)

Step 1: Locate the ledge near the spray shield (1) and with 001-6707MA in hand, mark out drill locations for the two slots of the 6707MA bracket. Bracket should be as centered about the spray shield. If you are confident with drill locations, drill the two holes and move to step 2. Also note the factory drilled holes on the tongue of the baler (2), locate part 001-6707MC and ensure holes align on both sides.

Step 2: Assemble the wind guard (030-6707WG4). Start by locating all the materials listed above. Using the 1"x 1/4" bolts and washers place the guard material (001-6707GM4) on the top bracket. Guard material should now be held in place with only the bolts. Locate part (001-6707MB) and place over protruding bolts, secure with flat washers and nuts. Note: Ensure the rubber guard material is placed on the top side of the of the 6707MA bracket.

Step 3: Again, using the same hardware from step 2 fasten the guard material to the bottom bracket (001-6707MC) utilizing the remaining 001-6707MB backing bracket to clamp down the material.

Step 4: Bring assembled wind guard to the baler, it is recommended that you get another person to assist here. Start by securing the top bracket to the ledge where holes were previously drilled. Secure with 5/16 x 1" hardware. Now locate the 5/16 x 1.5" bolts. Use the bolts, flat washers, and nuts to secure the bottom bracket to the baler factory drilled holes. Refer to finished install side view shown on the right.

Note: If installed correctly, the wind guard should not contact the fly wheel or center feed roll when the pick-up head is fully lifted.

Complete Wind Guard Kit Part Number: 030-6707WG4



Mounting Solenoids and Hose Routing to Spray Shield



- A. Once spray shield is mounted, ensure solenoids 002-2203F are mounted using the solenoid mount plate 001-4648DSH as closely as possible (max distance 3ft) to the spray shield. This will ensure the most precise application of the preservative.



Solenoids
002-2203F



Solenoid Mount
001-4648DSH



Solenoid Harness
006-3650-S1

- B. Once solenoids are mounted, streamline solenoid harness 006-3650-S1 along baler back to connection on main baler harness 006-765B. Solenoid with white dot attaches to SOL 1 and Solenoid with blue dot attaches to SOL 2. Connect harnesses and ensure they are secure.
- C. Route hoses along the path or similar inside of the baler, as shown in picture above. Keep hoses away from moving parts and hydraulic hoses. When all connections are made to the tank, solenoids, and spray shield secure with existing cable clamps or use cable ties.
- D. Connect hoses from spray shield to solenoids. Note: Make sure solenoid with white dot attaches to spray shield with white dot. Follow same procedure for blue dots.

Tip Connections

Dot color	Tip	Hose color	Position on 765B2 wire
White Dot	8004 or 11004	White	Sol 1
Blue Dot	8008 or 11008	Blue tracer	Sol 2

Main Wire Harness and Baler Interface Harness Routing and Connections



Route harness (006-765B) along inside of the baler. Keep harnesses away from moving parts and hydraulic hoses. Secure with existing cable clamps or use cable ties. When all connections are made to the IPM secure wires.



Locate the CAN port on the baler and attach baler ISO integration harness (006-765VA) to that location.



A. Route harness 006-765B along this path or similar inside of the baler. Keep harnesses away from moving parts and hydraulic hoses. Secure with existing cable clamps or use cable ties. When all connections are made to the ISO Pump Module (IPM) secure wires to allow for water to be shed away from the IPM.

B. The Baler Power/Communication Harness (006-765B) will attach to the open port of the Tractor Harness (006-765IC) and run back to the ISO Pump Module (006-7671LS). Connect the large plug of the Baler Power/Communication Harness (006-765B) to the plug of the IPM.

C. Attach Baler Interface Harness (006-765VA) to the additional CAN port at front of baler. Make sure Active Terminator is removed from the back underside of the baler is attached to the Baler Interface Harness (006-765VA).

D. Once Baler Interface Harness is connected to the CAN plug, power up the applicator system and setup baler display settings to allow Harvest Tec applicator to communicate. See DISPLAY SETUP pages for further instruction on how to setup baler display settings.

Installation of Star Wheel Moisture Sensors

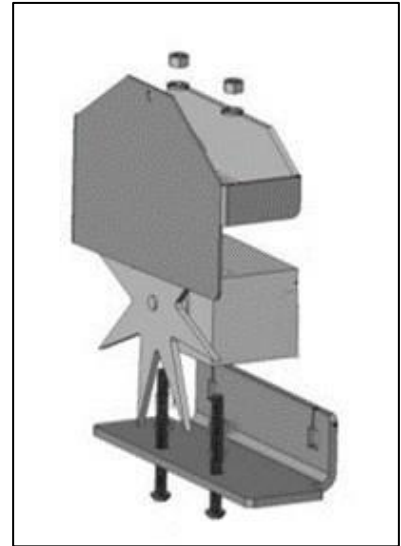
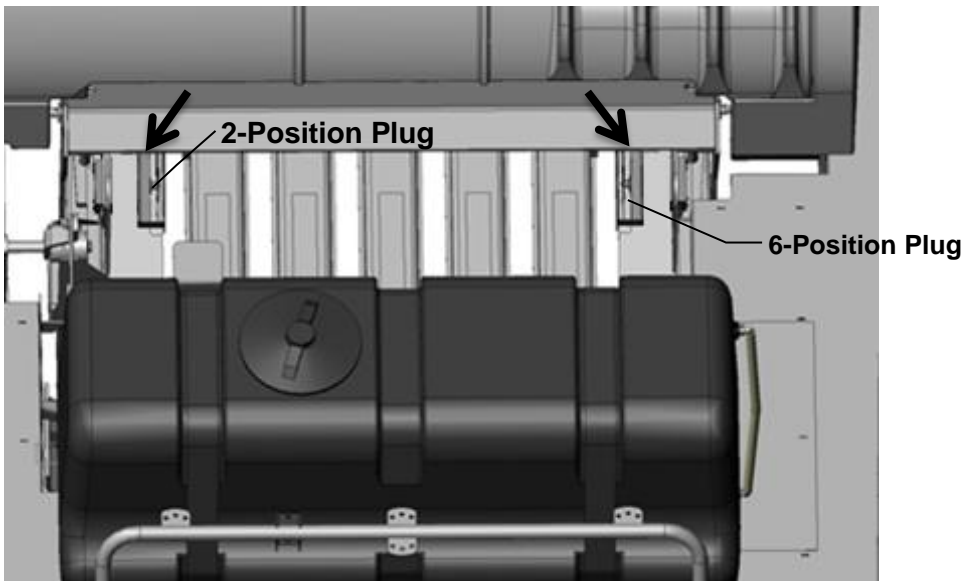

1. Locate the two-star wheel moisture sensors (030-4642U / UE) twine diverters (001-4644 / 4645) and parts bag E.
2. Directly behind the knotters, locate the two predrilled holes per side shown at the arrows. This location is also beneath the lift points on top of the baler.
3. Install the four (two per side) 5/16" x 3" Allen head cap screws. Make sure the Allen heads are in the bale chamber.
4. Install the star wheels below the lift points on the baler. Ensure arrow diagram is followed on back of star wheel blocks.
5. Install the twine diverters over the star wheel sensor. Note: diverter with two extra holes needs to attach to star wheel with 6 position plug.
6. Secure the star wheels and twine diverters with two 5/16" hex nuts, and lock washers.
7. Attach harness (006-7307EM2) wires to star wheels and route to pump module and connect.

Installation of End of Bale Sensor

The end of bale sensor determines the position of the needles on the baler. When the needles cycle the sensor communicates this information to the ISO Communication Module (ICM). This information is used for job records and will be used by the optional Bale Identification system.

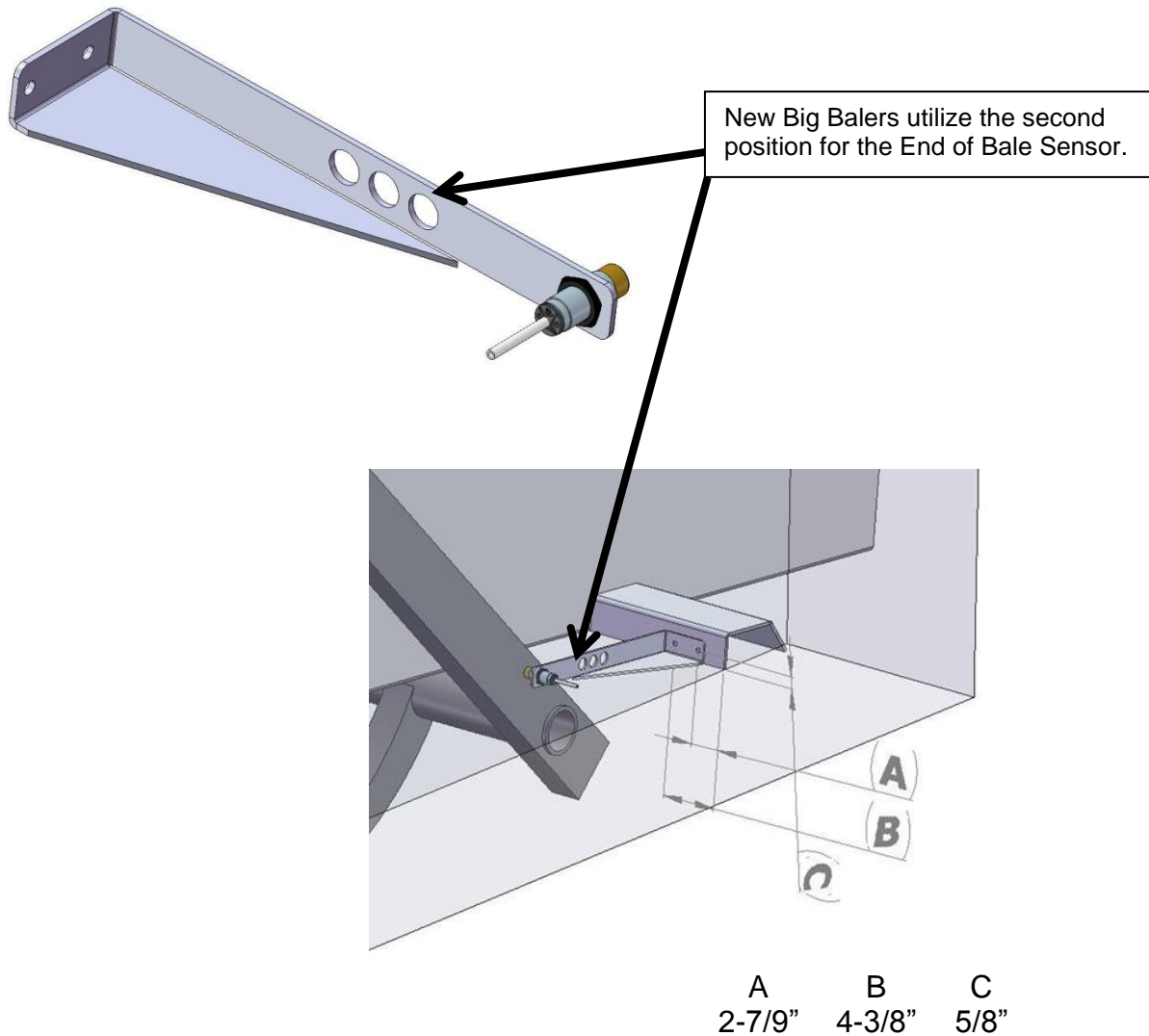

Mount the end of bale sensor bracket (001-4648) as shown on the ladder side of the baler. Mark and drill two 3/8" (10mm) holes and attach the bracket using two 5/16" x 1" self-tapping screws, and 5/16" flange nuts. Keep the sensor 1/4" (7mm) from the needle and tighten both nuts. New BB Balers have been installing the End of Bale Sensor in the second position and trimming off the excess steel. Run the sensor cable (006-7401) and extension (006-7401BBEXT) up to main harness (006-765B) and attach to EOB plug.

Tractor Setup

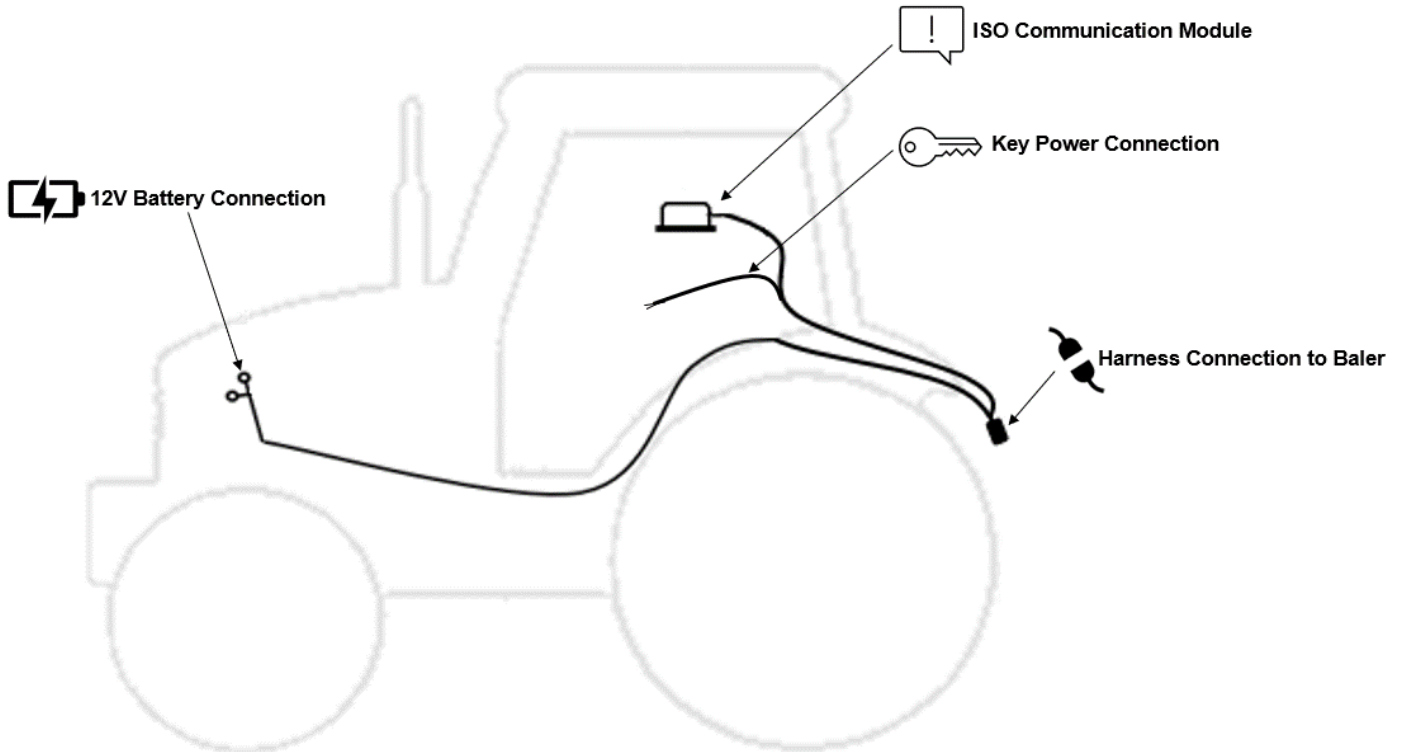

The general tractor setup of the 700 Series applicator can be seen above. The main harness of interest is the tractor power/communication harness (006-7651C). This harness will connect at the tractor battery, to the ISO Communication Module (ICM) mounted in the cab, a keyed power connection point, and connect at the hitch area to the baler power/communication harness (006-765B). View below to see highlighted installation instruction:



12V Battery Connection

The 12V battery connection must be at the tractor battery. Connection to alternative locations such as an accessory port can cause problems with applicator system.

MUST BE CONNECTED DIRECT TO TRACTOR BATTERY TERMINALS



ISO Communication Module

The ISO communication module is to be mounted inside the cab. Other mounting locations can lead to issues with weathering and operation. Once installed and the system is powered, a green light will turn on with the ICM module.



Key Power Connection

Ensure a solid keyed connection is found inside the cab and wired into. Poor keyed power connection can result in applicator system issues.



Harness Connection to Baler

The tractor harness connects at the hitch to baler power/communication harness (006-765B). This will allow the system components to communicate with one another. Ensure connections are debris and corrosion free.

Display Options

Optional Harvest Tec Display



The 700 series Harvest Tec Display will allow you to set your real time baling parameters to ensure the most precise application to every bale. This is done by utilizing the improved touch technology to select objects, enter data, and swipe through operational screens.

The Harvest Tec Display offers easy integration by connecting to the additional CAN plug on the 006-765IC harness. Once, connected the Harvest Tec display will power up with applicator system.

Note: The Harvest Tec Display must be used as a standalone display, the baler cannot run both integrated and on the Harvest Tec Display. Must be one or the other. Removal of the 006-765VA or integration harness is required when equipped.

Optional Tablet Display



The iOS or Android Tablet displays offer the ability to communicate with the 700 series applicator system via hard-wired connection to the ISO Communication Module (ICM). Through the free Precision Baling App, the operator can set real time baling parameters to ensure the most precise application to every bale. This provides a multi-use option while utilizing the improved app to select objects, enter data, and easily switch through operational screens. The Tablet Display offers easy integration by connecting a charging cable to the USB port on the ICM module. Once connected the Harvest Tec applicator will display upon opening the app and powering up the applicator system. Tablets can be used in addition to integrated baler VT display.

***Made for iPad®**

Required to be running the most current operating system or one version previous.

*iPad is a trademark of Apple Inc., registered in the U.S. and other countries.

Optional Baler VT Integration



The 700 series integration to the Baler VT allows for the ability to set your real time baling through the baler VT and monitor both baler settings and Harvest Tec system parameters on one screen to ensure the most precise application to every bale.

The 700 series offers easy integration by connecting to the additional CAN plug on the 006-765B harness. Once connected the Harvest Tec system will display with power up of the baler and applicator system.

Baler Display Integration

The ISOBUS Monitor utilizes touch screen options to make selections. Selections are made by finding the desired selection and pressing the touch screen icon. All buttons are labeled and color coded.



When the 700 Series is connected to the baler and powered on the first time it is necessary to load the object pools to the Virtual Terminal (VT).



Icon (1) indicates that the object pools are in the process of loading and saving to the VT. Note that if the language selection of the VT is changed, the corresponding object pool must be reloaded to the VT. The object pool loading process takes approximately two minutes to complete.

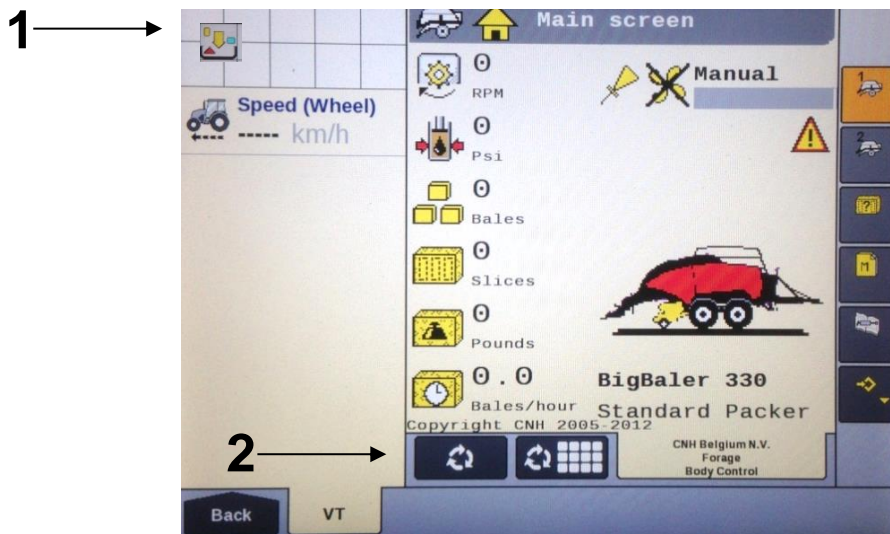

Once the object pools have been loaded and Icon (1) disappears from the upper left corner of the display, press the NEXT IMPLEMENT button (2) and verify that the 700 Series object pools appear on the Virtual Terminal.

After verifying that the 700 Series object pool is loaded and the operating screens are displayed on the VT, press the NEXT IMPLEMENT button (3) to return to the baler work screen page.

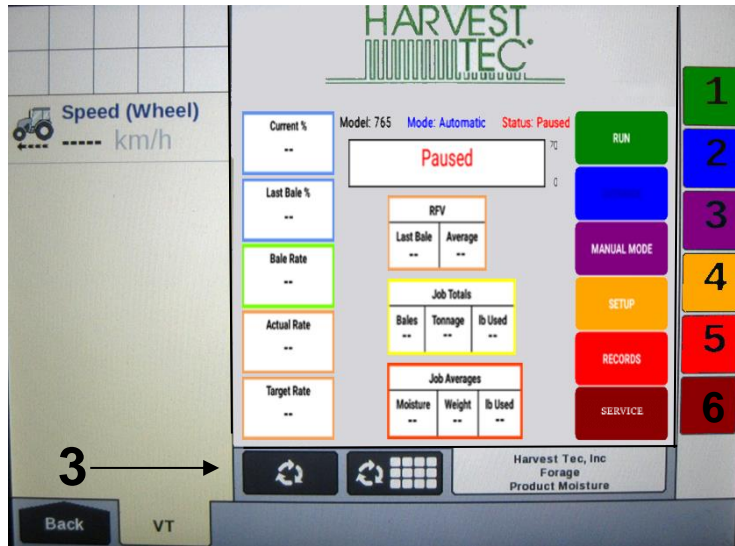

Press the bottom button of the Menu Bar with the down arrow in corner (4) on the side of the screen to continue down the Menu Bar below the USER SETTING icon.

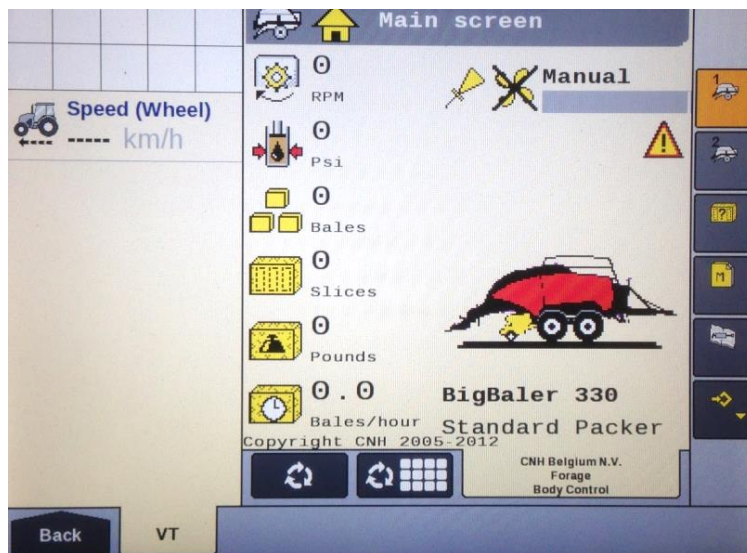

Scroll through the Menu bar until the INFORMATION icon (5) is visible. Press the INFORMATION button so the Information page appears. Verify that the controller software loaded to the baler is version 4.2.0.0 or higher. If not, contact the dealer to update firmware in Baler Control Module (BCM). If the controller software displays version 4.2.0.0 or higher proceed to configuring the baler for the 700 series system by pressing the MACHINE SETUP button (6).

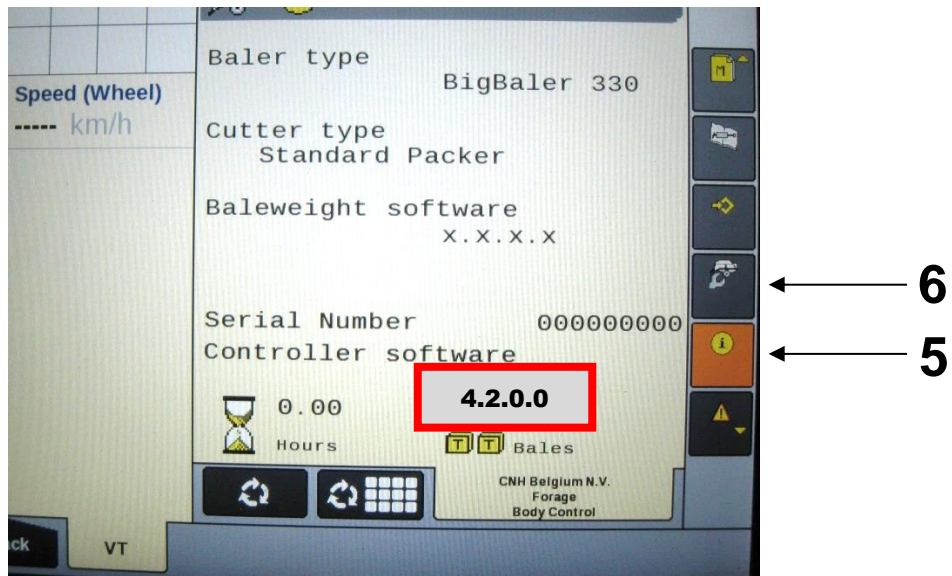

Once the MACHINE SETUP icon has been selected, the Machine Setup page will appear, and the icon will be backlit in orange. Press the MACHINE SETUP icon (7) again to go to the second page of the Machine Setup.



The second page of the Machine setup is identified by the three gray buttons in the Menu Bar. Press and hold the third gray button (8) for 10 seconds or until the display switches to displaying Dealer Mode.

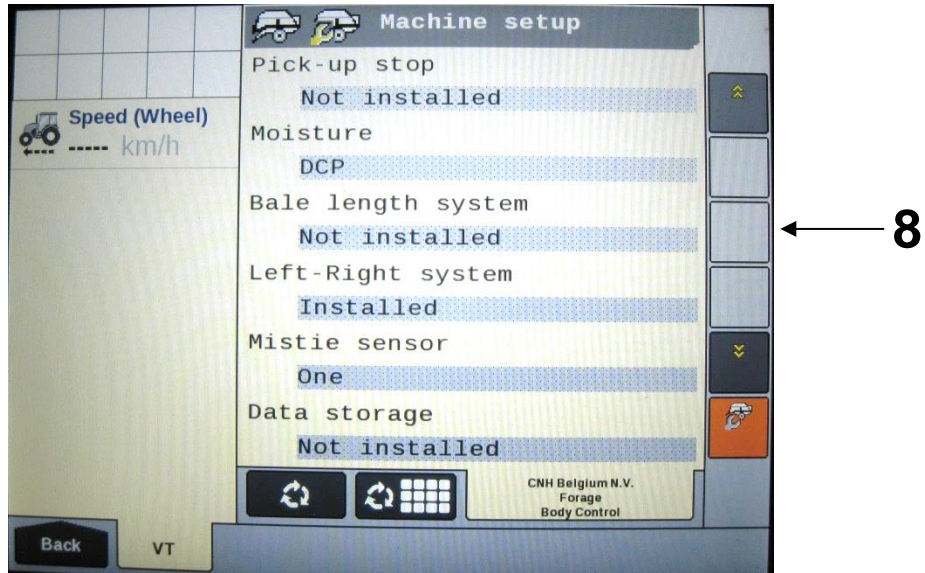

Once Dealer Mode has been entered, select the down arrow in the Menu Bar (9) to scroll to the second Dealer Mode Screen where 'Moisture' is a selection.

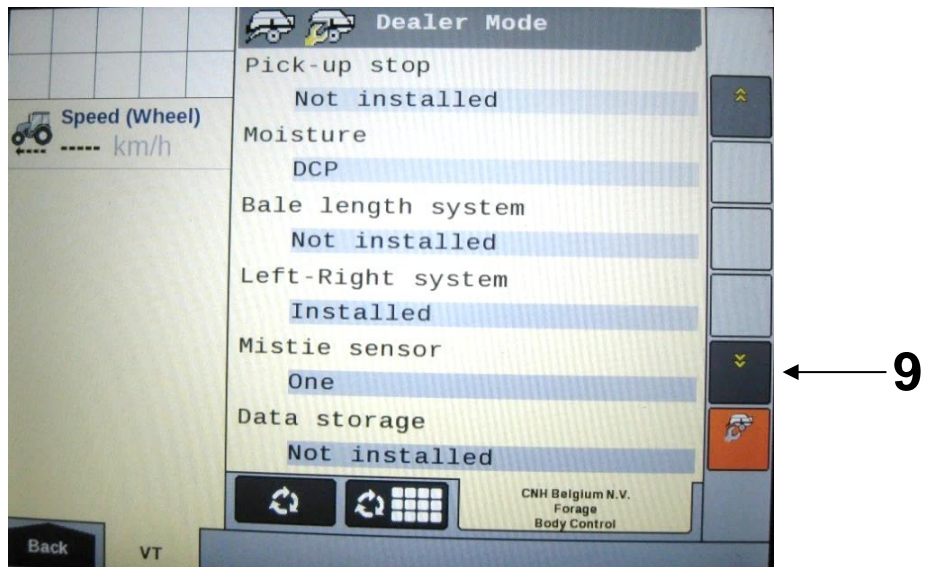

Once you have reached the second Dealer Mode screen, select the area under 'Moisture' (10). Note that the box below 'Moisture' will likely be the default "NOT INSTALLED".

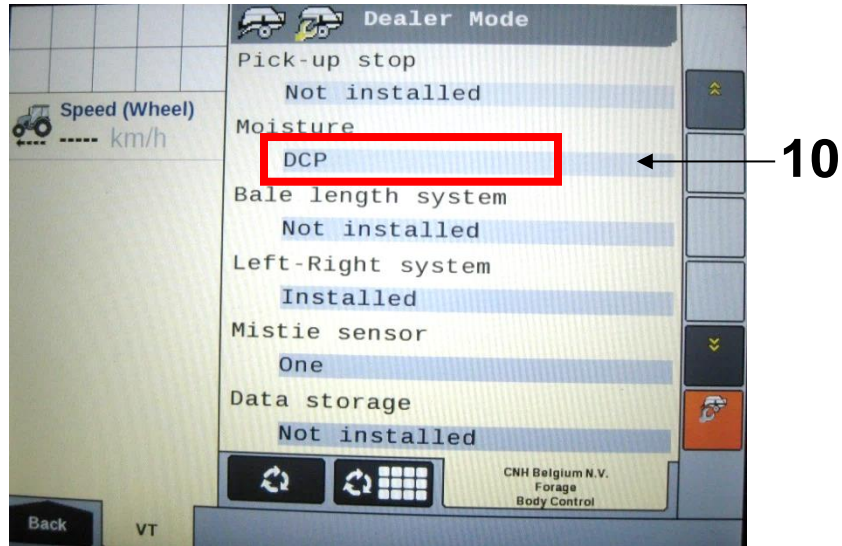

Select the proper configuration setting from the pop-up menu (11), based on the configuration of your 700 series system. This configuration setting allows the baler to properly display the information it is receiving from the 700 series system on the baler working screen. Select "DCP."

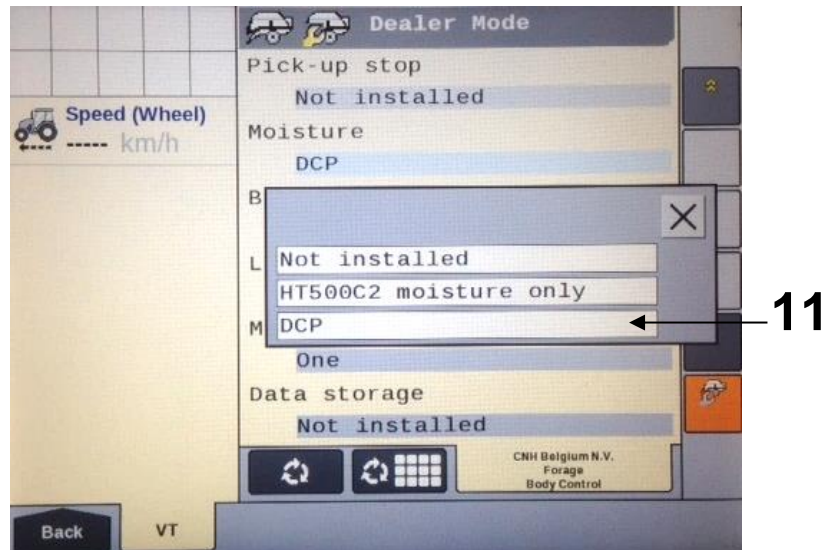

Once the configuration has been set press the MACHINE SETUP icon (12) to return to the Machine Setup Screen and the Menu Bar.

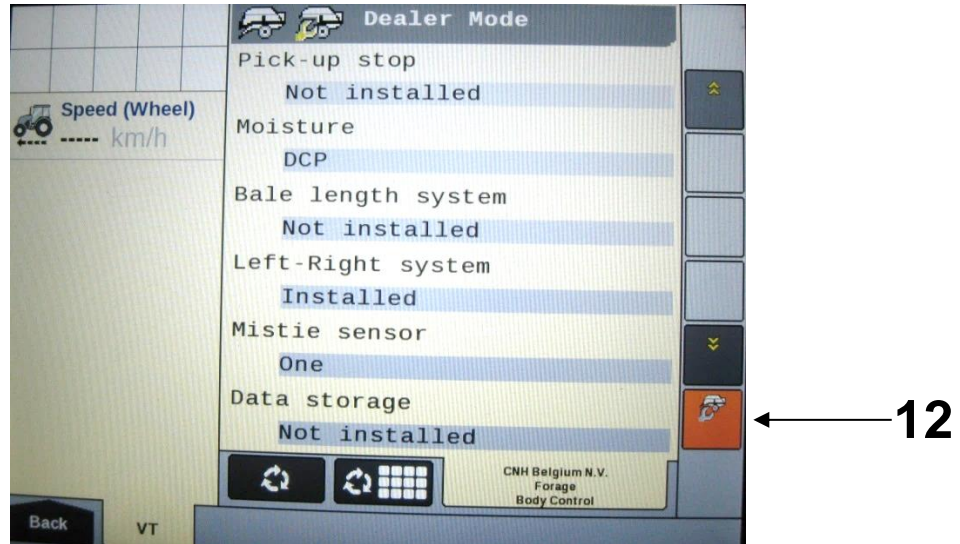

Press the arrow down button at the bottom of the Menu Bar (13) to scroll down thru the Menu Bar until you reach the SCREEN SETUP pages.

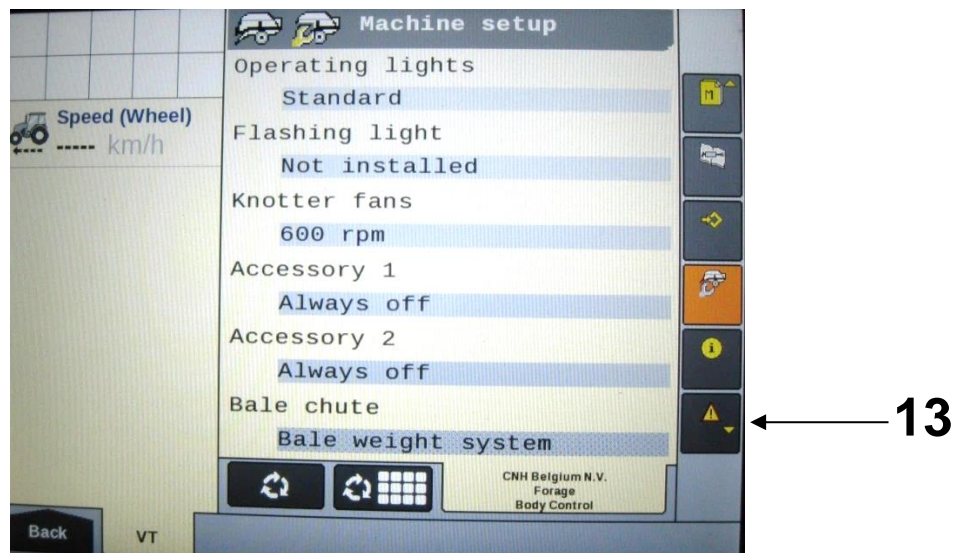

Select the icon for SCREEN SETUP 1 (14) so the Screen Setup 1 screen appears. Select how you would like to have the screen configured to show a combination of baler and 700 series system information by selecting the boxes. When you select one of the boxes, a pop-up screen will appear that shows the selections available.

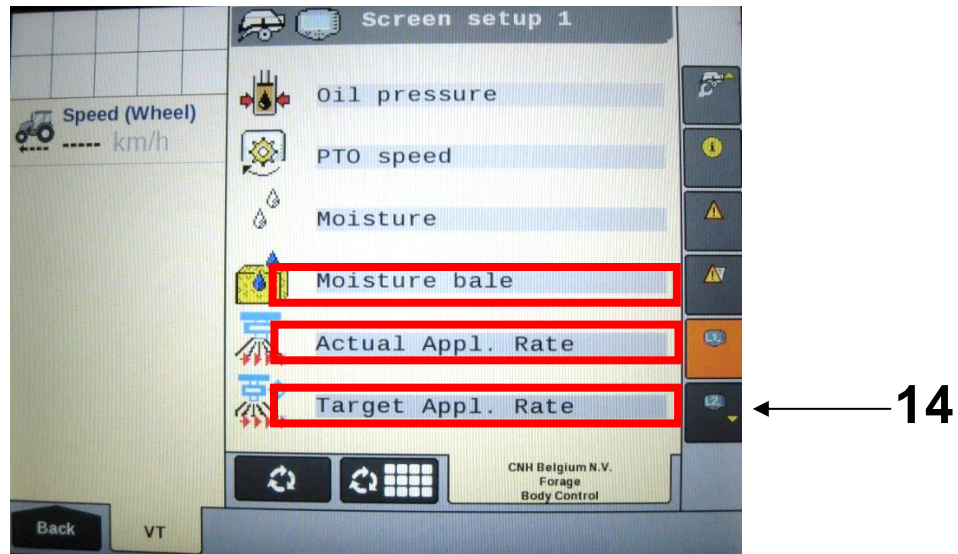

Selections related to the 700 series system include Moisture, Moisture Bale, Target Application rate, and Actual Application Rate, and are highlighted by arrows above and in the next picture. Scroll to additional options in the popup window by pressing the down arrow on the side of the popup window (15).

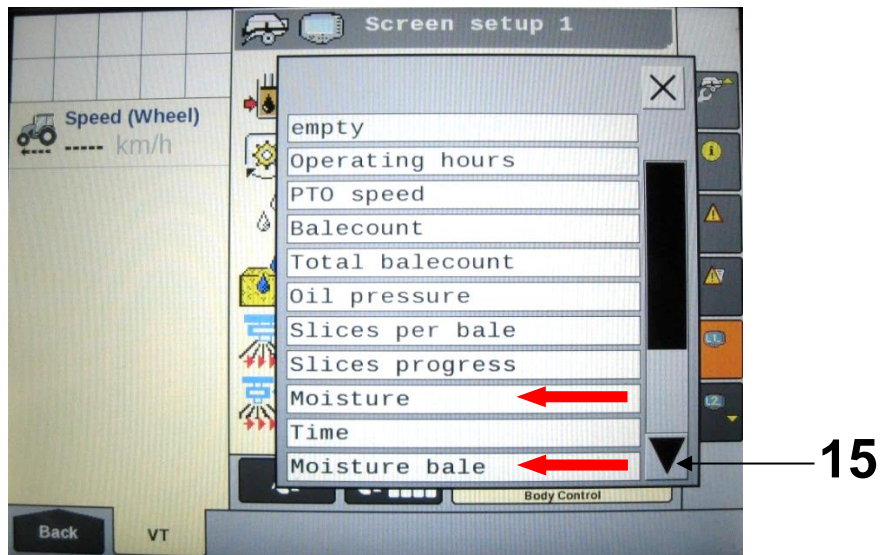

Once the Screen Setup pages have been configured, scroll back up to the top of the Menu Bar by pressing the top button in the Menu Bar with the up arrow (16).



Select the FIELD SETTING icon (17) and adjust the Moisture Alarm Settings in the Field Setting Screen. Note that the low moisture alarm must be set lower than the high moisture alarm. The moisture alarms can be turned off by setting the low setting <9% and the high setting >70%. When the alarms are turned off, they will say OFF next to the values. Select the MAIN SCREEN 1 icon (18) from the Menu Bar.

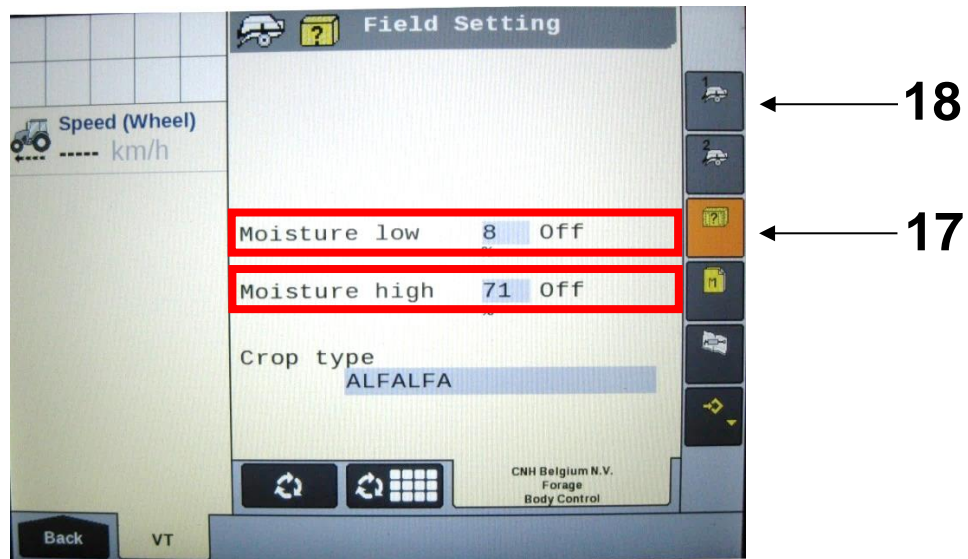

Verify that your MAIN SCREEN 1 and MAIN SCREEN 2 are configured as you would like them displaying the information you would like visible during operation. During operation, information for the 700 series system that you have chosen to display will be displayed on the Baler Work Screen.

Cycle back and forth between the Baler Work Screen and the 700 Series System Work Screen by pressing the NEXT IMPLEMENT button (19) during operation.

Harvest Tec Icons signified by arrows 19-25 are as follows:

- (19) Next Implement Button
- (20) Moisture Content %
- (21) Last Bale Average Moisture Content %
- (22) Actual Application Rate of Preservative
- (23) Target Application Rate of Preservative
- (24) IPM Status Icon
- (25) Tagger Status Icon

The status icon (24) indicates the system is connected to the baler. An "X" over the status icon indicates the system is:

- A) Not in an application mode
- B) Paused through
 - a. Manual Pause
 - b. Hay Indicator Pause
 - c. Baler End of Row (EOR) Pause (PTO speed < 600 rpm)

When the Tagger Status Icon (25) is visible the system is indicating the Tagger is activated. When the system is not in application mode or has been paused there will be an "X" over the Tagger Status Icon.

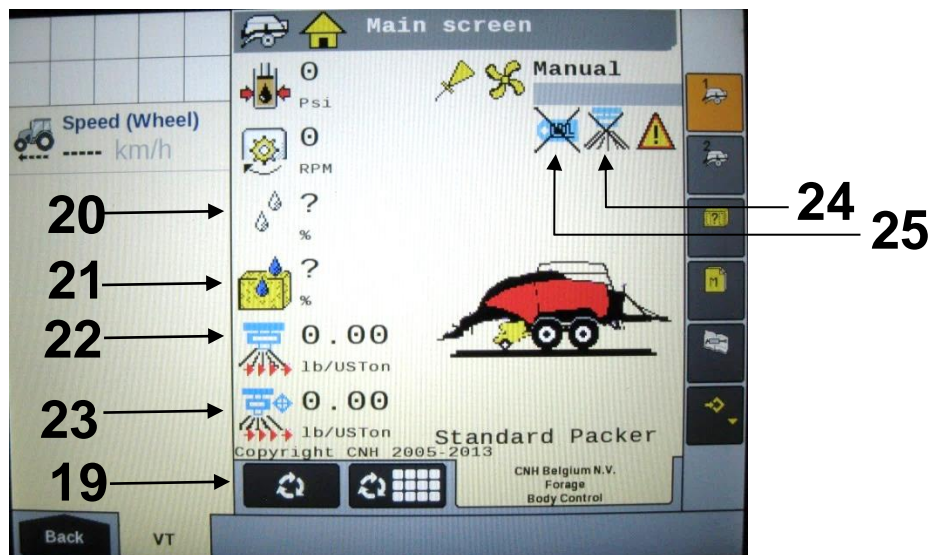

Wiring Diagram – 700 Series

1. Connect the power harness (006-7651C) to the tractor battery (12 volt) using the red wire with fuse to the positive side and the black wire to the negative.



**A. The power harness must be connected to the battery!
CONTACT HARVEST TEC BEFORE MODIFICATIONS.**

The unit will draw more amps than convenience outlets can handle. Any modifications of the power harness will void systems warranty

B. This unit will not function on positive ground tractors.

C. If the unit loses power while operating it will not keep track of accumulated pounds of product used.

2. The power harness on the tractor (006-7651C) will run from the tractor battery to the hitch. The power harness on the baler (006-765B) will connect to the tractor power harness (006-7651C) at the hitch.
3. Connect the keyed power wire (006-765CPH) to a keyed power source on the tractor.
The keyed power wire must connect to a keyed source or the unit will not power up correctly.
4. Attached the ISO Communication Module (006-7671) to the tractor power harness (006-7651C).
5. Attach the End of Bale (EOB) connection on baler harness (006-765B) to the EOB Sensor (006-7400).
6. Attach the Flowmeter (006-4724A) to ISO Pump Module connection on pump plate assembly.
7. Attach the rubber molded connector on pump plate to the Pump (007-4120DE).
8. Attach star wheel (030-4642 U/UE) connection to ISO Pump Module on pump plate assembly.

System Wiring Diagram

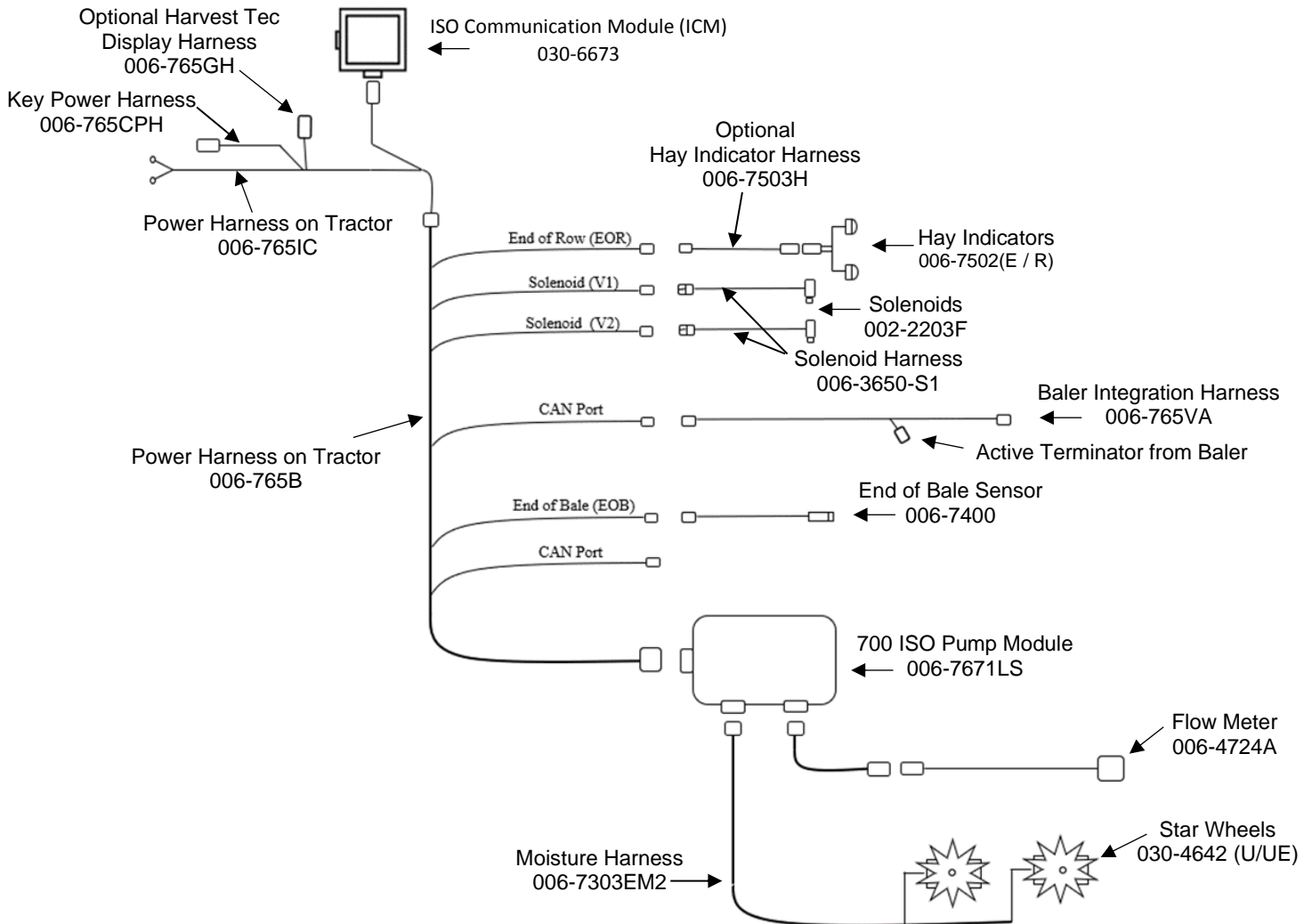

Pin Outs

Integrated Control Module (ICM) on harness 006-765IC

(Deutsch Plug Number: DTM06-12SA)

Pin 1	Red	+12V from ECU
Pin 2	Purple	Signal Wire
Pin 3	Red/White	+12V CAN X
Pin 4	Black/White	Ground CAN X
Pin 5	Orange	CAN X Hi
Pin 6	Blue	CAN X Lo
Pin 7	Green	ISO CAN Lo
Pin 8	Yellow	ISO CAN Hi
Pin 9	White	GPS Extension 1
Pin 10	Gray	GPS Extension 2
Pin 11	Brown	GPS Extension 3
Pin 12	Black	Ground from ECU

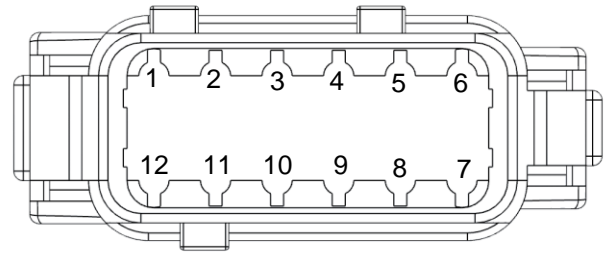

ISOBUS Plug on harness 006-765IC

(Deutsch Plug Number: DT04-4P)

Pin 1	Red	+12V from ECU
Pin 2	Yellow	ISO CAN Hi
Pin 3	Green	ISO CAN Lo
Pin 4	Black	Ground from ECU

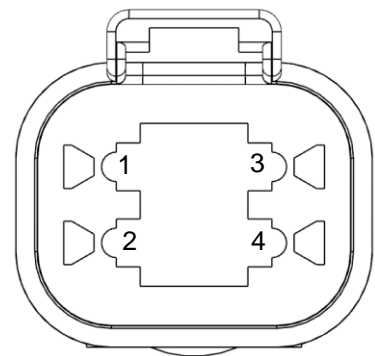

Power / Communication Harness 006-765IC at Baler Hitch

(Deutsch Plug Number: HDP24-24-18PN)

Pin 1	Not Used	----
Pin 2	Yellow	ISO CAN Hi
Pin 3	Green	ISO CAN Lo
Pin 4	Red	+12V Power to ECU
Pin 5	Black	Ground to ECU
Pin 6	Red	+12V From Battery
Pin 7	Not Used	----
Pin 8	Black	Ground From Battery
Pin 9	Not Used	----
Pin 10	Purple	Signal Wire
Pin 11	Red/White	+12V CAN X
Pin 12	Black/White	Ground CAN X
Pin 13	Orange	CAN X Hi
Pin 14	Blue	CAN X Lo
Pin 15	White	GPS Extension 1
Pin 16	Gray	GPS Extension 2
Pin 17	Brown	GPS Extension 3
Pin 18	Not Used	----

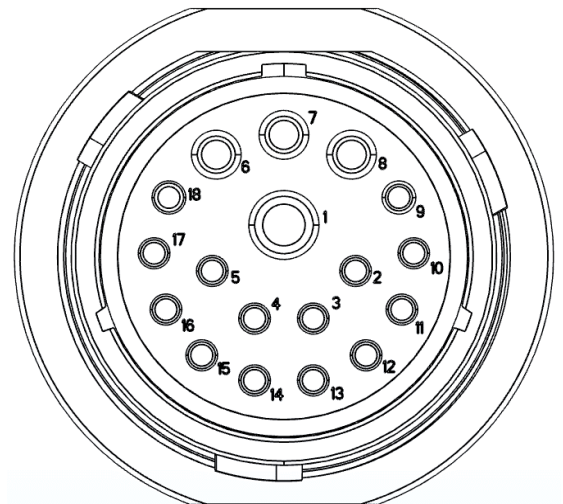

Power / Communication Harness 006-765B at Baler Hitch IPM

(Deutsch Plug Number: HDP26-24-18SN)

Pin 1	Not Used	----
Pin 2	Yellow	ISO CAN Hi
Pin 3	Green	ISO CAN Lo
Pin 4	Red	+12V Power to ECU
Pin 5	Black	Ground to ECU
Pin 6	Red	+12V From Battery
Pin 7	Not Used	----
Pin 8	Black	Ground From Battery
Pin 9	Not Used	----
Pin 10	Orange/White	+12V Power to EOR
Pin 11	Not Used	----
Pin 12	Not Used	----
Pin 13	Not Used	----
Pin 14	Not Used	----
Pin 15	Not Used	----
Pin 16	Not Used	----
Pin 17	Not Used	----
Pin 18	Not Used	----

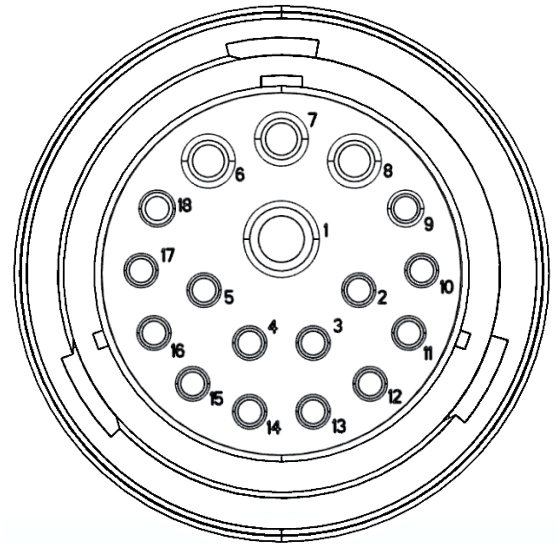

Power / Communication Harness 006-765B at IPM Module

(Deutsch Plug Number: HDP24-24-18SN)

Pin 1	Not Used	----
Pin 2	Yellow	ISO CAN Hi
Pin 3	Green	ISO CAN Lo
Pin 4	Red	+12V Power to ECU
Pin 5	Black	Ground to ECU
Pin 6	Red	+12V From Battery
Pin 7	Not Used	----
Pin 8	Black	Ground From Battery
Pin 9	Not Used	----
Pin 10	Orange/White	+12V Power to EOR
Pin 11	Orange/Black	Ground to EOR
Pin 12	Purple/Green	EOR Signal
Pin 13	Blue/White	EOB Signal
Pin 14	Gray/Red	+12V Power to Solenoid 1
Pin 15	White/Black	Ground to Solenoid 1
Pin 16	Orange/Red	+12V Power to Solenoid 2
Pin 17	White/Black	Ground to Solenoid 2
Pin 18	Not Used	----

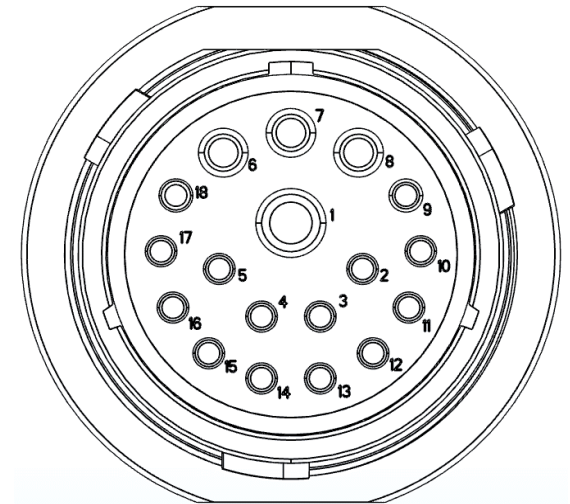

*IPM Module Whip Plug- Pin # 5 Not Used

Solenoid 1 Plug on Baler Harness 006-765B

(Deutsch Plug Number: APTIV 12052641)

Pin B	Gray/Red	+12V to Solenoid 1
Pin A	White/Black	Ground to Solenoid 1

Solenoid 2 Plug on Baler Harness 006-765B

(Deutsch Plug Number: APTIV 12052641)

Pin B	Orange/Red	+12V to Solenoid 2
Pin A	White/Black	Ground to Solenoid 2

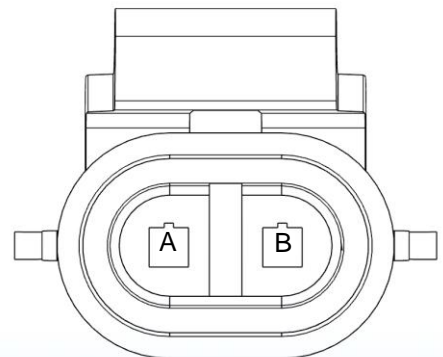

CAN / IDM on Baler Harness 006-765B

(Deutsch Plug Number: DT06-4S)

Pin 1	Red	+12V to ECU
Pin 2	Yellow	ISO CAN Hi
Pin 3	Green	ISO CAN Lo
Pin 4	Black	Ground to ECU

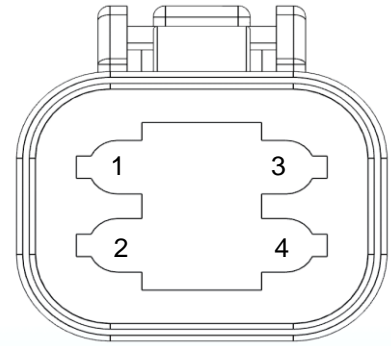

End of Bale Sensor Plug on Baler Harness 006-765B

(Deutsch Plug Number: DT06-3S)

Pin 1	Orange/White	+12V to End of Bale Sensors
Pin 2	Orange/Black	Ground to End of Bale Sensors
Pin 3	Blue/White	Signal

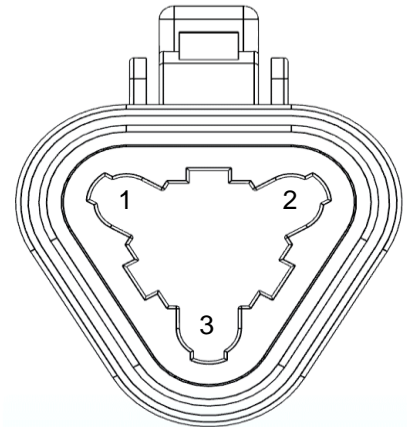

End of Row Sensors Plug on Baler Harness 006-765B

(Deutsch Plug Number: DT06-3S)

Pin 1	Orange/White	+12V to End of Bale Sensors
Pin 2	Orange/Black	Ground to End of Bale Sensors
Pin 3	Blue/White	Signal

Integration Harness Plug on Baler Harness 006-765VA

(Plug: APTIV 12052848)

Pin A	Not Used	----
Pin B	Red	TBC Power
Pin C	Not Used	----
Pin D	Gray	TBC Ground
Pin E	Orange	CAN Hi
Pin F	Blue	CAN Lo

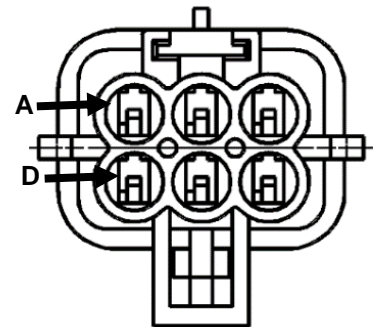

Pump Connection on 700 Controller Harness

(16 AWG Two-Wire Plug)

Pin 1	Red	Power to Pump
Pin 2	Black	Ground to Pump

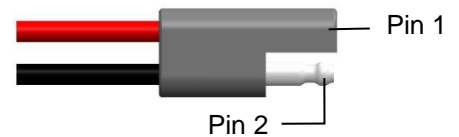

Parts Breakdown

Parts Breakdown for Tank, Saddle and Saddle Legs

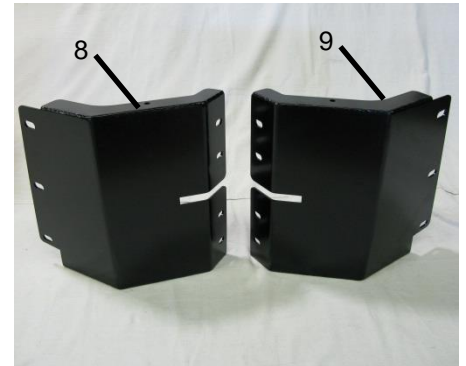
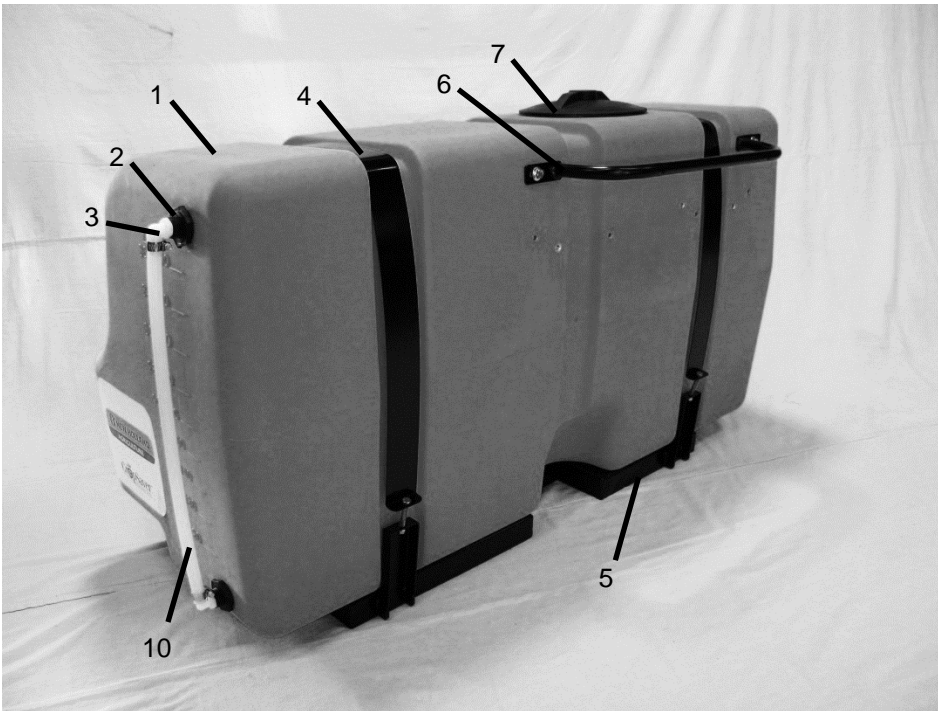

<u>Ref</u>	<u>Description</u>	<u>Part Number</u>	<u>Qty</u>	<u>Ref</u>	<u>Description</u>	<u>Part Number</u>	<u>Qty</u>
1	Tank	005-9218	1	9	Right saddle leg	001-6707MR	1
2	1/2" tank fitting	005-9104	2	10	1/2" hose	002-9001	2
3	Elbow	003-EL1212	2	NP	Not Pictured:		
4	Tank straps	001-6707P	2	NP	Elbow	003-EL3434	1
5	Tank saddle	001-6707N	1	NP	Elbow	003-EL3412	1
6	Handrail	001-6707HR	1	NP	3/4" tank fitting	005-9100	2
7	Tank lid	005-9022H	1				
8	Left saddle leg	001-6707ML	1				

Parts Breakdown for Pump Assembly

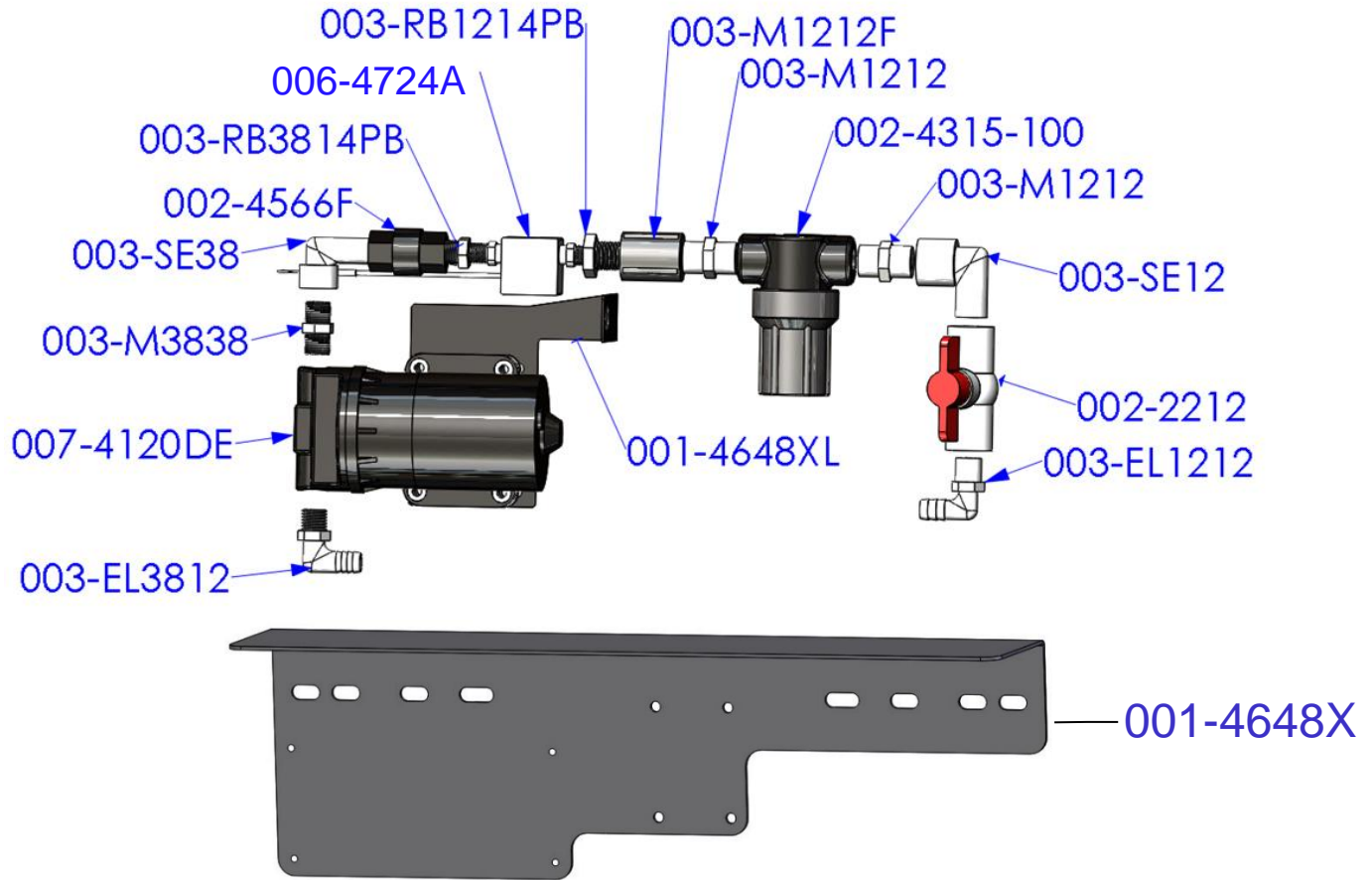

<u>Part#</u>	<u>Description</u>	<u>Qty</u>	<u>Part#</u>	<u>Description</u>	<u>Qty</u>
003-EL3812	3/8" MPT X 1/2"HB Elbow	1	003-M1212	1/2" Union	2
007-4120DE	300 Series Pump	1	002-4315-100	1/2" Line Strainer-100 Mesh	1
003-M3838	3/8" x 3/8" Union	1	003-SE12	1/2" Street Elbow	1
003-SE38	3/8" Street Elbow	1	002-2212	1/2" Ball Valve	1
002-4566F	3/8" Check Valve	1	003-EL1212	1/2"MPT x 1/2"HB	1
003-RB3814PB	RB 3/8" x 1/4" Reducer	1	001-4648XL	300 Pump Support	1
006-4728R	Flow Meter – Block Style	1	001-4648X	Pump Plate Mount	1
003-RB1214PB	RB 1/2" x 1/4" Reducer	1	003-A1212	Not Pictured	1
003-M1212F	1/2" Coupler	1	003-A3812	Not Pictured	1

Completed Assembly

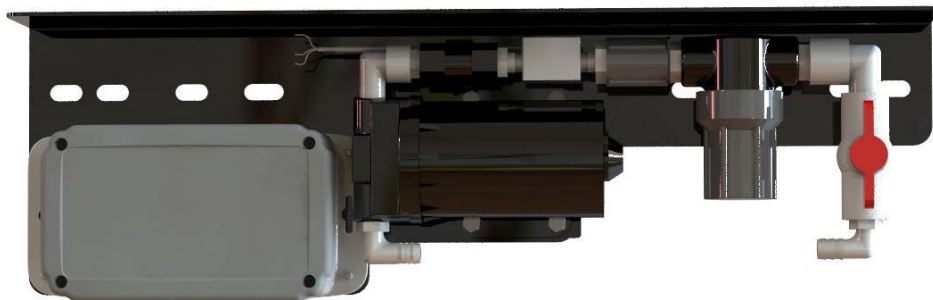

*Note: Due to alternative baler designs, elbow 003-EL3812 can be replaced by straight fitting 003-A3812. As well as elbow 003-EL1212 can be replaced by straight fitting 003-A1212. Both straight fittings are included.

Star Wheel Sensors

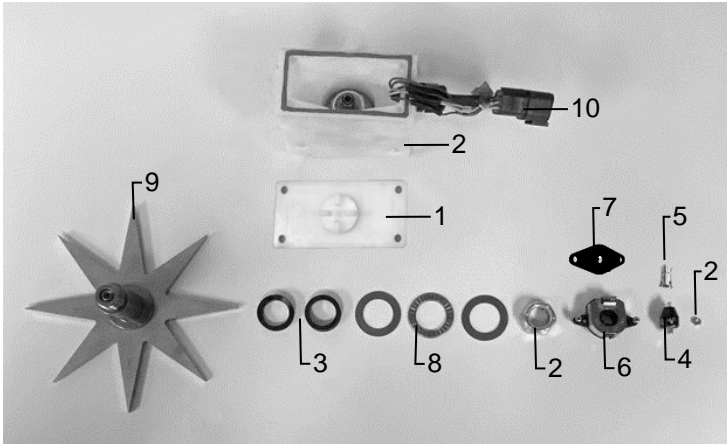

<u>Ref</u>	<u>Description</u>	<u>Part#</u>	<u>Qty</u>
1	Block Cover	006-4642UC	1
2	Star Wheel Block	006-4642UB	1
3	Star Wheel Gasket	006-4642UG	1
4	Electric Swivel	006-4642A	1
5	Swivel Insert	006-4642B	1
6	Encoder	006-4512E	1
7	Encoder Mount	006-4512P	1
8	Washers	006-4642K	1
9	Star Wheel	006-4641C	1
10	Encoder Harness (6 pin)	006-7307EM	1
NP	Moisture Harness (2 pin)	006-7307M	1
1-10	Star wheel assembly (w/ Encoder)	030-4642UE	1
1-5, 8, 9, NP	Star wheel assembly (w/o Encoder)	030-4642U	1

Hoses



<u>Ref</u>	<u>Description</u>	<u>Part #</u>	<u>Qty</u>
11	1/2" Hose (Tank to Solenoid)	002-9001	30ft
12	1/4" Hose (Solenoid to Tips)	002-9016	6ft

Moisture Harness



<u>Ref</u>	<u>Description</u>	<u>Part #</u>	<u>Qty</u>
1	Moisture Harness	006-7307EM2	1

Control Box and Wiring Harnesses



<u>Ref</u>	<u>Description</u>	<u>Part#</u>	<u>Qty</u>	<u>Ref</u>	<u>Description</u>	<u>Part#</u>	<u>Qty</u>
1	Power Lead Baler 20'	006-765B	1	NP	Baler Integration Harness	006-765VA	1
2	Power lead tractor	006-765IC	1	NP	Dust Plug Kit	006-765DP	1
3	Key Switch Wire	006-765CPH	1				
4	ISO Pump Module	006-7671LS	1				
5	ISO Communication Module	006-6673	1				

End of Bale Sensor Kit

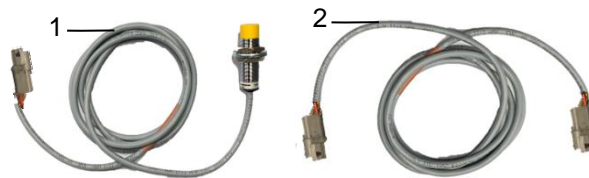

<u>Ref</u>	<u>Description</u>	<u>Part #</u>	<u>Qty</u>
1	End of Bale Sensor	006-7401	1
2	End of Bale Ext.	006-7401BBEXT	1

700 Solenoid Package

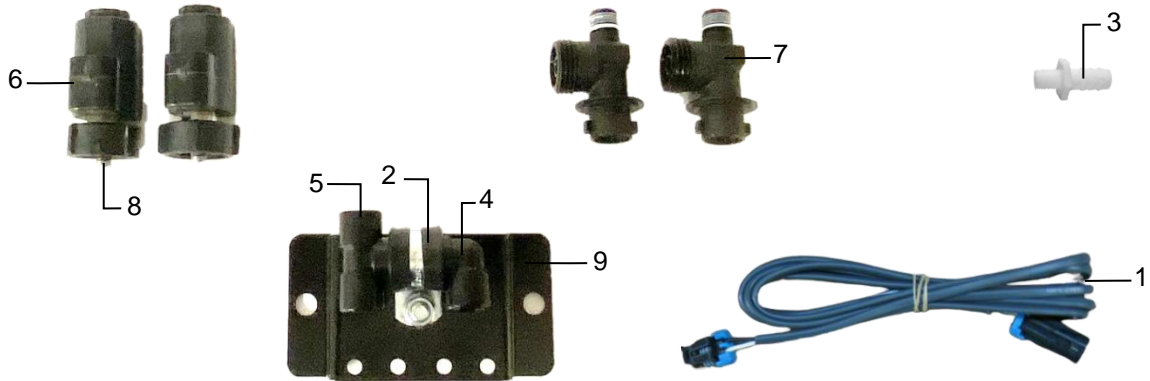

Solenoid Package

<u>Ref</u>	<u>Description</u>	<u>Part #</u>	<u>Qty</u>	<u>Ref</u>	<u>Description</u>	<u>Part #</u>	<u>Qty</u>
1	Solenoid Harness (5')	006-3650-S1	2	6	Solenoid	002-2203F	2
2	Hose Clamp #6	003-9003	1	7	Solenoid Check Valve	004-1207VF	2
3	1/4" x 1/2" Straight Fitting	003-A1412	1	8	1/4" Nipple	003-M14	2
4	1/4" Elbow	003-SE14F	1	9	Solenoid Holder	001-4648DSH	1
5	1/4" Tee Fitting	003-TT14SQ	1	NP	O-Ring Kit	002-2203FG	2
					Complete Assembly	SOL-3SP-LSB	

Hose and Drain/Fill Line

PBA-1

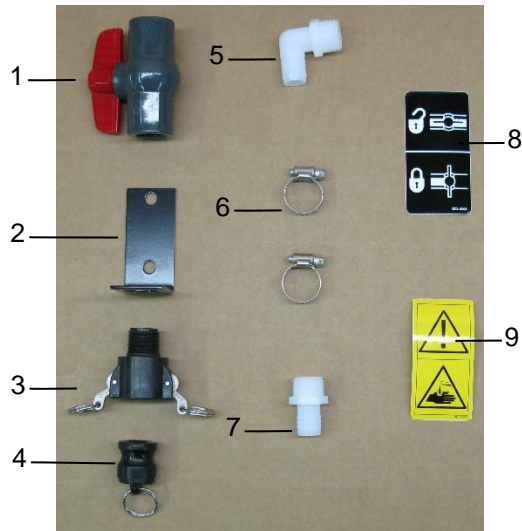

<u>Ref</u>	<u>Description</u>	<u>Part #</u>	<u>Qty</u>
1	3/4" Ball Valve	002-2200	1
2	Valve Holder	001-6702H	1
3	Female Coupler	002-2204A	1
4	Male Shut-Off Plug	002-2205G	1
5	3/4" x 3/4" Elbow	003-EL3434	1
6	#10 Hose Clamp	003-9004	2
7	3/4" x 3/4" Straight Fitting	003-A3434	1

PBP-16

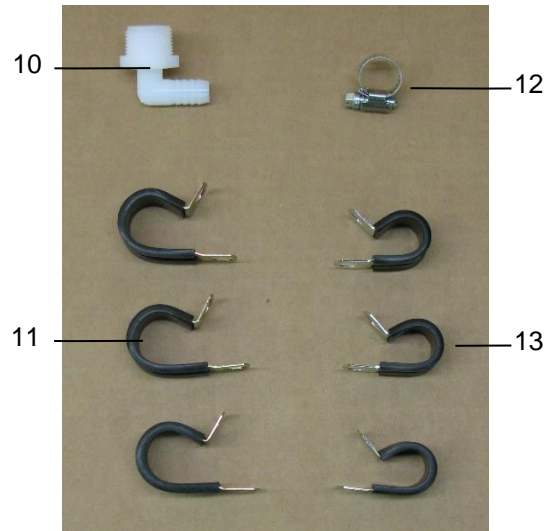

<u>Ref</u>	<u>Description</u>	<u>Part #</u>	<u>Qty</u>
8	Valve Decal	DCL-8004	1
9	Hazard Decal	DCL-8001	1
10	3/4" x 1/2" Elbow	003-EL3412	1
11	3/4" Jiffy Clip	008-9010	3
12	#6 Hose Clamp	003-9003	1
13	Small Jiffy Clip	008-9009	3
10	3/4" x 1/2" Elbow	003-EL3412	1

Complete Drain Fill Kit 030-0493DFK

Optional iPad Mini Mounting Kit (030-2014MK)

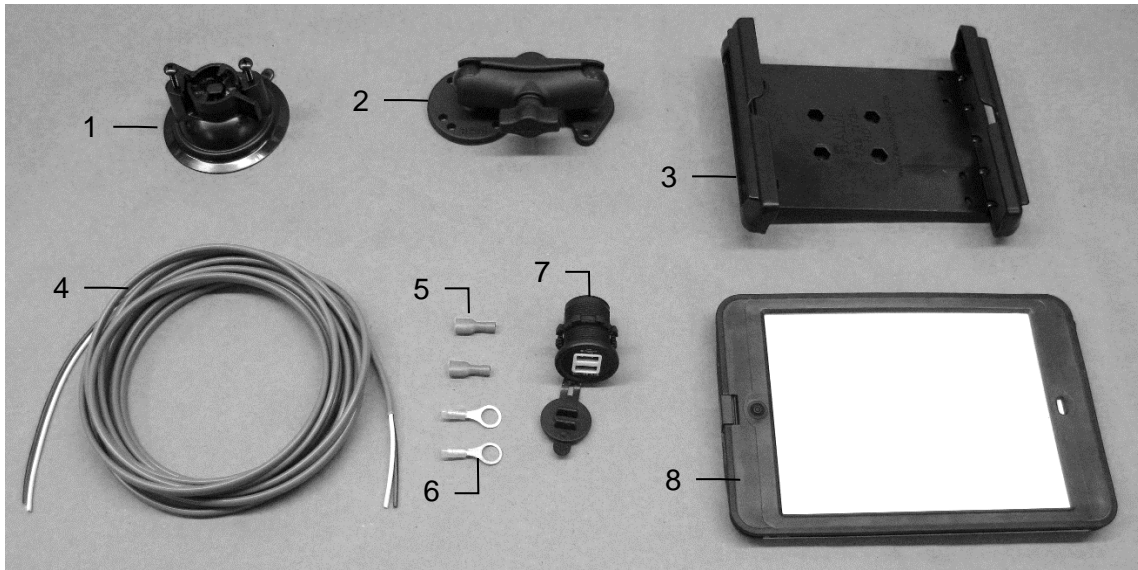

<u>Ref</u>	<u>Description</u>	<u>Part #</u>	<u>Qty</u>
1	Suction cup mount	001-2012SCM	1
2	Ram mount	001-2012H	1
3	iPad Mini® spring load cradle (Mini 4)	001-2012SLC	1
4	16 gauge power wire	006-4723P	1
5	Female spade connector	Hardware	2
6	Eye loop connector	Hardware	2
7	iPad Mini Charger 12V	001-2012P	1
8	iPad Mini 4 case	001-2012C4	1
NP	4 amp fuse	Hardware	1

Mounting Kit Assembly

030-2014MK
(Includes All Parts)

Installation Instructions

1. Identify 12V power source for wires to connect.
 - a. Eye loops included if wiring directly to the battery is desired.
 - b. Test for key power source if preferred to have power to the USB shut off with the key.
2. Once power source is identified, cut wires to desired length.
3. Crimp the two supplied quick connectors onto each the white and black wire.
4. Remove the round locking plastic nut from USB plug before connecting the wires. Black (+) White (-).
5. The wires will then be hooked to the designated terminals on the bottom of the USB plug
6. Drill a 1 1/8" hole in the preferred mounting location. Be sure to clean any sharp edges after drilling.
7. Feed the wires through the mounting hole.
8. If using the round plastic nut to secure plug in place, slide the nut back over the wiring before connecting the wires to powered source.
9. Connect the wires to the identified power source if easier to do so before tightening the plug into place.
10. Tighten plug using either the round plastic nut or mounting plate and two screws, both options supplied.
11. Once connected, hook a USB charging cord into the plug and connect a mobile device/tablet to ensure the plug is operating as you wish (key power working properly if necessary).

*iPad mini is a trademark of Apple Inc., registered in the U.S. and other countries.

Optional iPad Display Kit (030-4670DK)

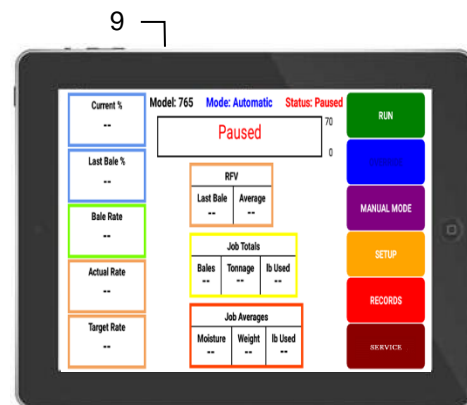
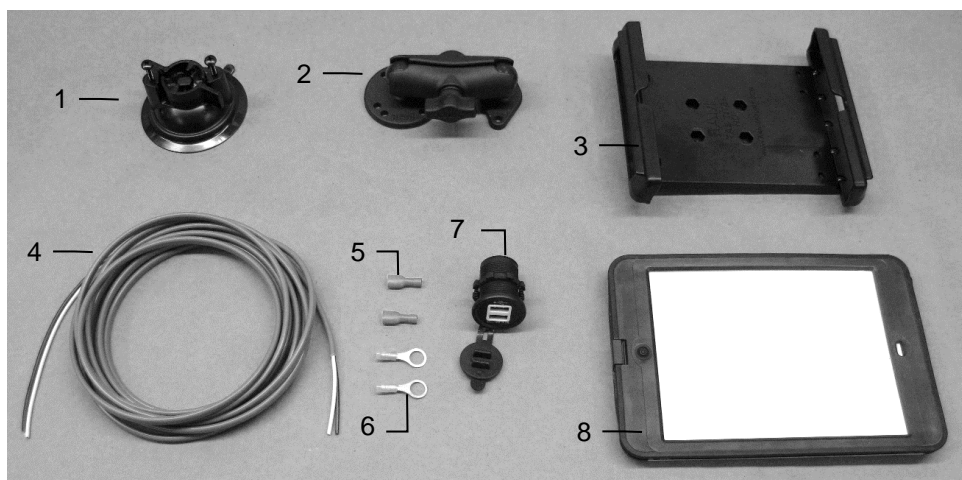

<u>Ref</u>	<u>Description</u>	<u>Part #</u>	<u>Qty</u>
1	Suction Cup Mount	001-2012SCM	1
2	Ram Mount	001-2012H	1
3	iPad Mini® Spring Load Cradle (Mini 2)	001-2012SLC	1
4	16 Gauge Power Wire	006-4723P	1
5	Female Spade Connector	Hardware	2
6	Eye Loop Connector	Hardware	2
7	iPad Mini Charger 12V	001-2012P	1
8	iPad Mini 4 case	001-2012C4	1
9	iPad Mini 4	006-2670IP	1
NP	4 Amp Fuse	Hardware	1

Mounting Kit Assembly

030-2014MK
(Includes All Parts)

Installation Instructions

- Identify 12V power source for wires to connect.
- Eye loops included if wiring directly to the battery is desired.
- Test for key power source if preferred to have power to the USB shut off with the key.
- Once power source is identified, cut wires to desired length.
- Crimp the two supplied quick connectors onto the white and black wire.
- Remove the round locking plastic nut from USB plug before connecting the wires. Black (+) White (-).
- The wires will then be hooked to the designated terminals on the bottom of the USB plug
- Drill a 1 1/8" hole in the preferred mounting location. Be sure to clean any sharp edges after drilling.
- Feed the wires through the mounting hole.
- If using the round plastic nut to secure plug in place, slide the nut back over the wiring before connecting the wires to powered source.
- Connect the wires to the identified power source if easier to do so before tightening the plug into place.
- Tighten plug using either the round plastic nut or mounting plate and two screws, both options supplied.
- Once connected, hook a USB charging cord into the plug and connect a mobile device/tablet to ensure the plug is operating as you wish (key power working properly if necessary).

NOTE: This plug is not designed to charge two iPads. System damage could occur if this is attempted. System will charge a mobile phone and iPad simultaneously without problem.

*iPad mini is a trademark of Apple Inc., registered in the U.S. and other countries.

Optional Harvest Tec Display Kit (030-7670DK)

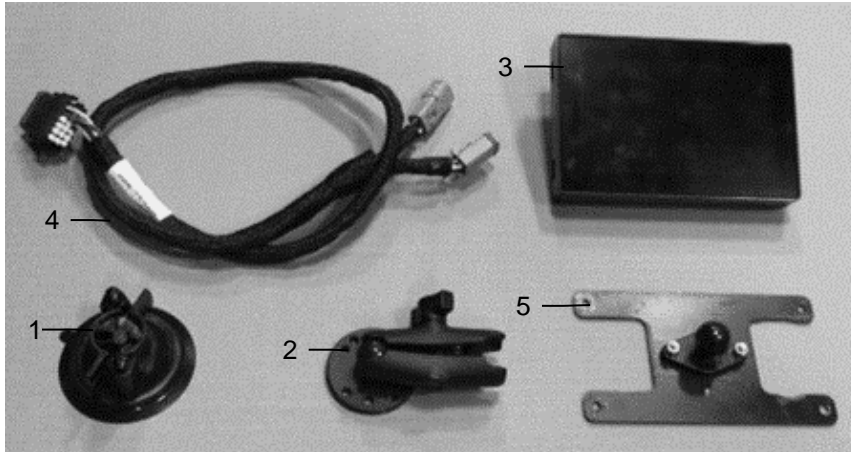

<u>Ref</u>	<u>Description</u>	<u>Part #</u>	<u>Qty</u>
1	Suction Cup Mount	001-2012SCM	1
2	Ram Mount	001-2012H	1
3	Harvest Tec Display	006-765GVT	1
4	Display Harness	006-765GH	1
5	Mounting Plate	001-700GH	1

Installation Instructions

1. Identify 006-765GH harness connection to 006-765IC tractor harness.
2. Connect harness to the Harvest Tec Display before tightening into place.
3. Tighten the mounting and display. Streamline harness, as necessary.
4. Once connected, power cycle system and ensure display is working properly.

NOTE: CANNOT OPERATE WITH BOTH HARVEST TEC DISPLAY AND BALER VT CONNECTED AT THE SAME TIME

4532C Installation Kit

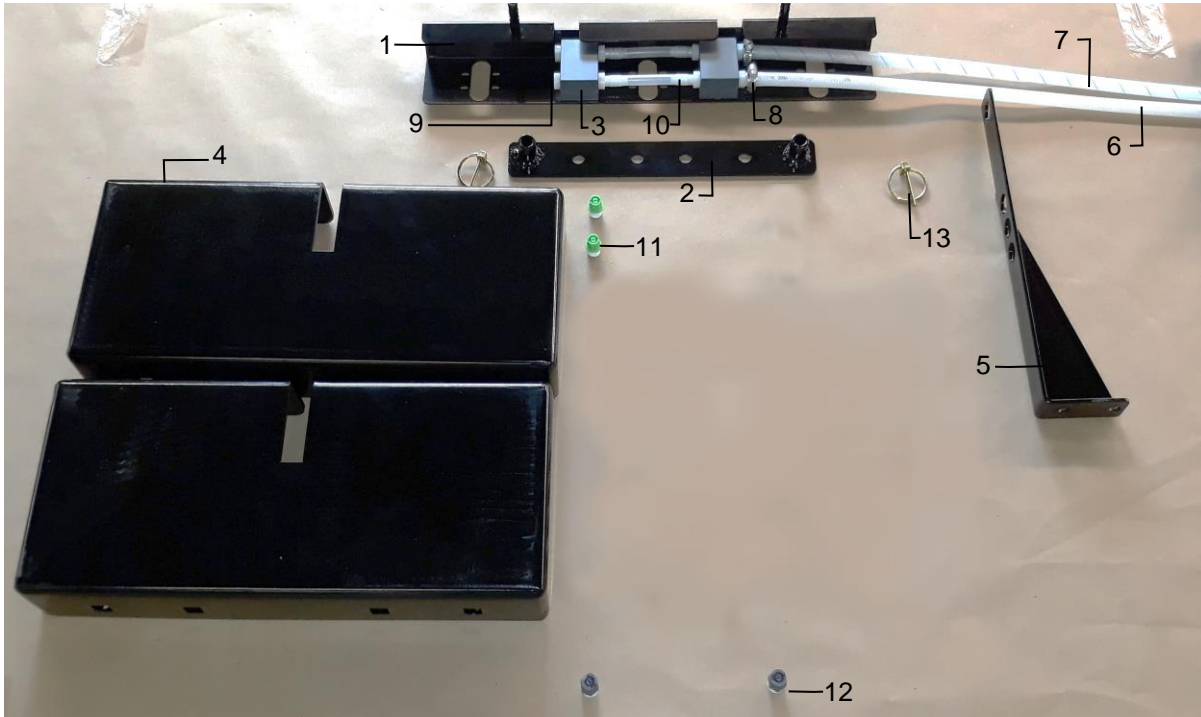

<u>Ref</u>	<u>Description</u>	<u>Part #</u>	<u>Qty</u>	<u>Ref</u>	<u>Description</u>	<u>Part #</u>	<u>Qty</u>
1	Spray Shield	001-4435NSX	1	8	Mini Hose Clamp	003-9002	4
2	Spray Shield Holder	001-4435NCX	1	9	1/4" Hex Plug	003-F14	2
3	Spray Manifold Block	001-4435NSB	2	10	1/4" x 1/4" Straight Fitting	003-A1414	8
4	Tank Leg Extension	001-6707MX	2	11	1/4" NPT Tip	004-T8008-PT	2
5	End of Bale Bracket	001-4648	1	12	1/4" NPT Tip	004-T8004-PT	2
6	1/4" Braided Hose	002-9016	4	13	3/16" Lynch Pin	004-4576	2
7	1/4" Braided Hose—Blue	002-9016B	4	NP	Rubber Washer	004-1207W	2
				NP	Female Quick Connect	004-1207H	2

*Tip color subject to change

Complete Installation Kit
(Ref. 1-13)

030-4532C

4533C Installation Kit

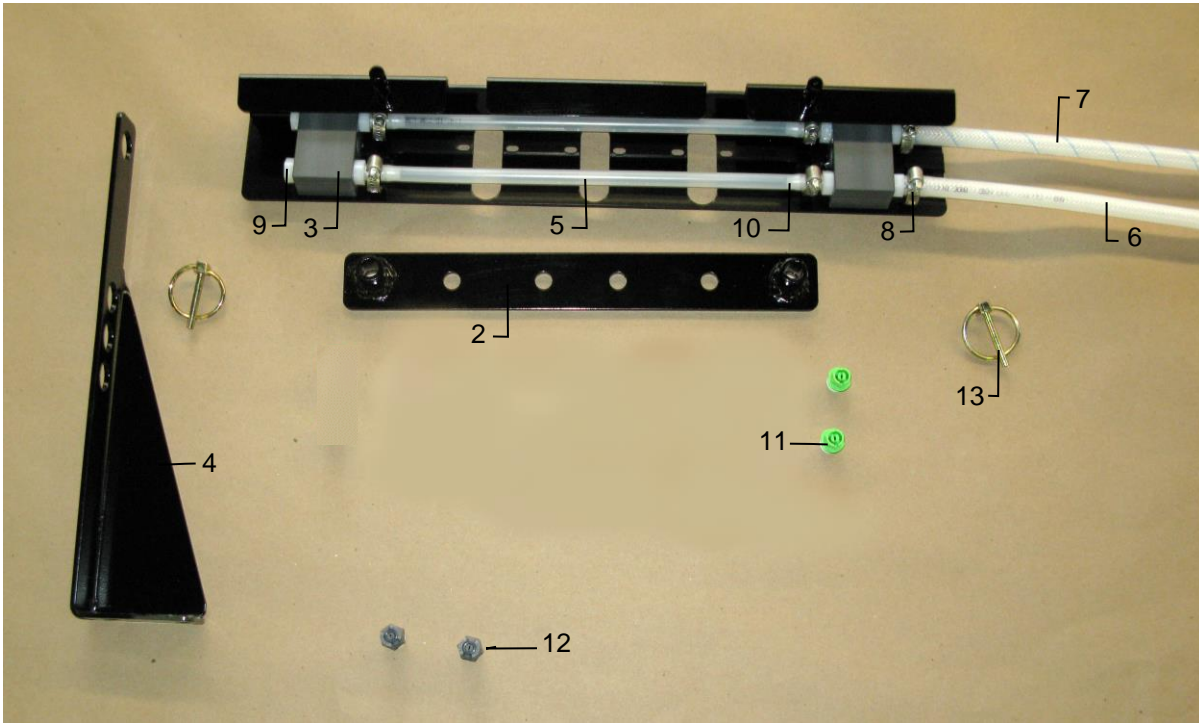

<u>Ref</u>	<u>Description</u>	<u>Part #</u>	<u>Qty</u>	<u>Ref</u>	<u>Description</u>	<u>Part #</u>	<u>Qty</u>
1	Spray Shield	001-4435NSX	1	8	Mini Hose Clamp	003-9002	8
2	Spray Shield Holder	001-4435NCX	1	9	1/4" Hex Plug	003-F14	2
3	Spray Manifold Block	001-4435NSB	2	10	1/4" x 1/4" Straight Fitting	003-A1414	8
4	End of Bale Bracket	001-4648	1	11	1/4" NPT Tip	004-T8008-PT	2
5	1/4" EVA Tubing	002-9006	2	12	1/4" NPT Tip	004-T8004-PT	2
6	1/4" Braided Hose	002-9016	4	13	3/16" Lynch Pin	008-4576	2
7	1/4" Braided Hose-Blue	002-9016B	4	NP	Rubber Washer	004-1207W	2
				NP	Female Quick Connect	004-1207H	2
				*Tip color subject to change			
				Complete Installation Kit (Ref. 1-13)		030-4533C	

4534C Installation Kit

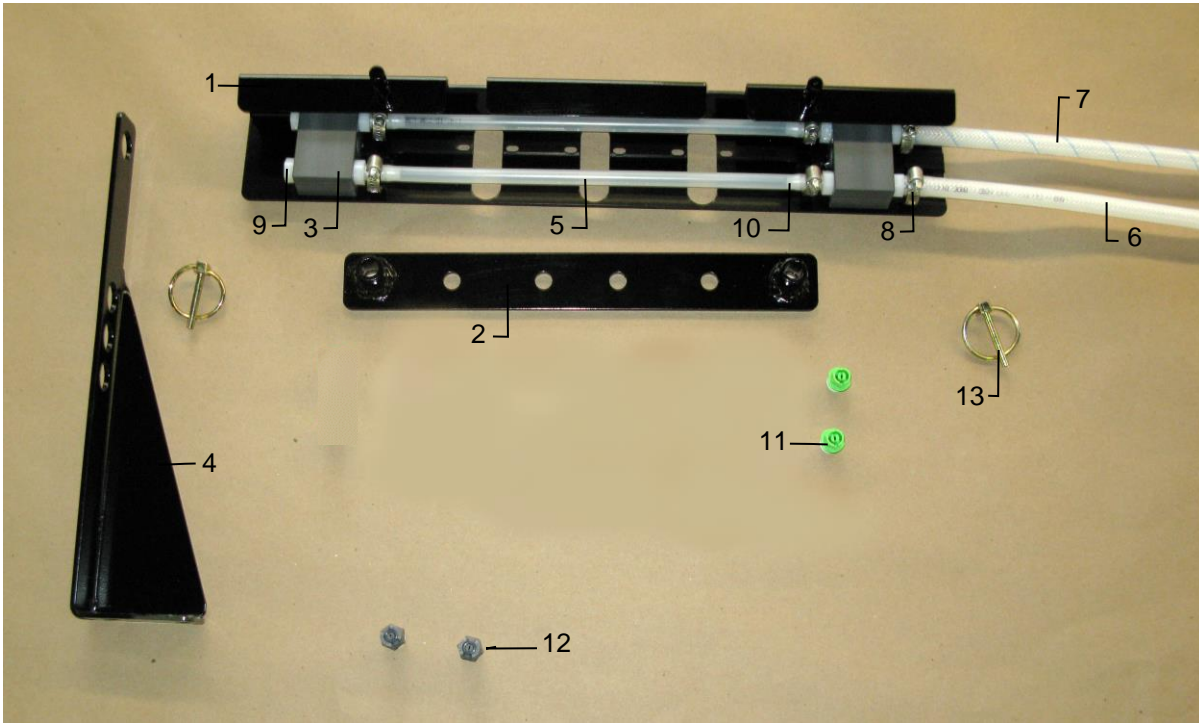

<u>Ref</u>	<u>Description</u>	<u>Part #</u>	<u>Qty</u>	<u>Ref</u>	<u>Description</u>	<u>Part #</u>	<u>Qty</u>
1	Spray Shield	001-4435NSX	1	8	Mini Hose Clamp	003-9002	8
2	Spray Shield Holder	001-4435NCX	1	9	1/4" Hex Plug	003-F14	2
3	Spray Manifold Block	001-4435NSB	2	10	1/4" x 1/4" Straight Fitting	003-A1414	8
4	End of Bale Bracket	001-4648	1	11	1/4" NPT Tip	004-T8008-PT	2
5	1/4" EVA Tubing	002-9006	2	12	1/4" NPT Tip	004-T8004-PT	2
6	1/4" Braided Hose	002-9016	4	13	3/16" Lynch Pin	008-4576	2
7	1/4" Braided Hose-Blue	002-9016B	4	NP	Rubber Washer	004-1207W	2
				NP	Female Disconnect	004-1207H	2

*Tip color subject to change

Complete Installation Kit
(Ref. 1-13)

030-4534C

4535C Installation Kit

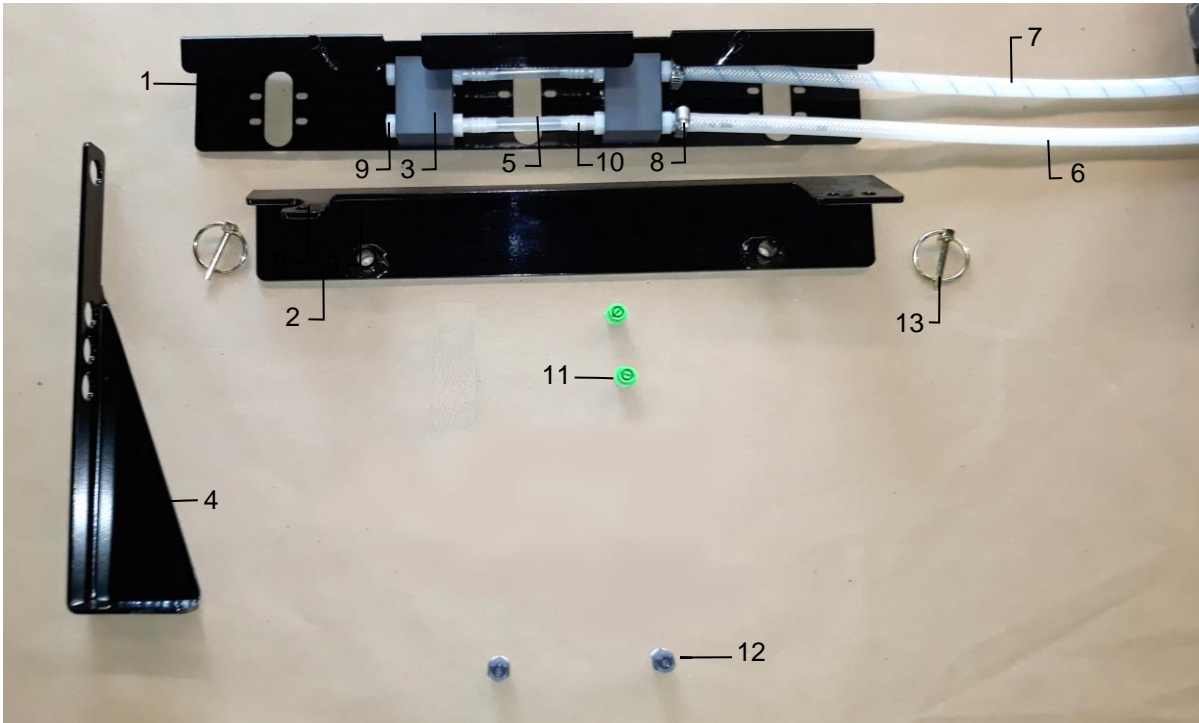

<u>Ref</u>	<u>Description</u>	<u>Part #</u>	<u>Qty</u>	<u>Ref</u>	<u>Description</u>	<u>Part #</u>	<u>Qty</u>
1	Spray Shield	001-4435NSX	1	8	Mini Hose Clamp	003-9002	4
2	Spray Shield Holder	001-4435NC	1	9	1/4" Hex Plug	003-F14	2
3	Spray Manifold Block	001-4435NSB	2	10	1/4" x 1/4" Straight Fitting	003-A1414	8
4	End of Bale Bracket	001-4648	1	11	1/4" NPT Tip	004-T8008-PT	2
5	1/4" EVA Tubing	002-9006	2	12	1/4" NPT Tip	004-T8004-PT	2
6	1/4" Braided Hose	002-9016	4	13	3/16" Lynch Pin	008-4576	2
7	1/4" Braided Hose-Blue	002-9016B	4	NP	Rubber Washer	004-1207W	2
				NP	Female Quick Disconnect	004-1207H	2

*Tip color subject to change

Complete Installation Kit 030-4535C
(Ref. 1-13)

4536C Installation Kit

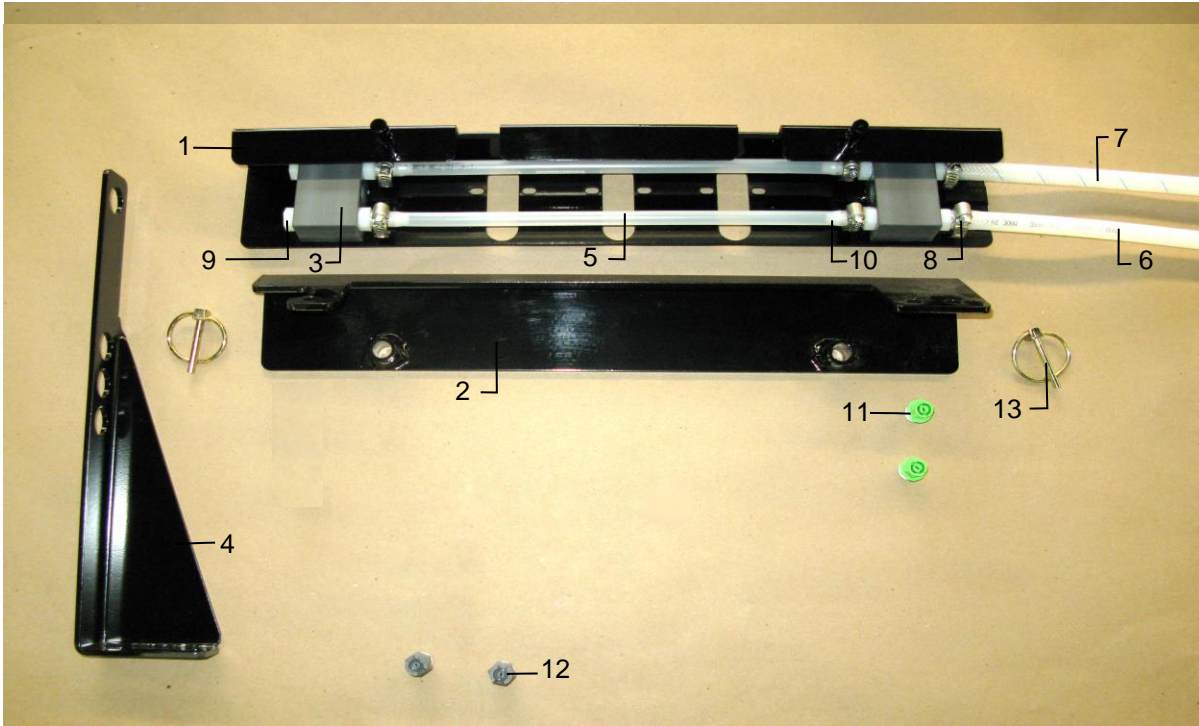

<u>Ref</u>	<u>Description</u>	<u>Part #</u>	<u>Qty</u>	<u>Ref</u>	<u>Description</u>	<u>Part #</u>	<u>Qty</u>
1	Spray Shield	001-4435NSX	1	8	Mini Hose Clamp	003-9002	8
2	Spray Shield Holder	001-4435NC	1	9	1/4" Hex Plug	003-F14	2
3	Spray Manifold Block	001-4435NSB	2	10	1/4" x 1/4" Straight Fitting	003-A1414	8
4	End of Bale Bracket	001-4648	1	11	1/4" NPT Tip	004-T8008-PT	2
5	1/4" EVA Tubing	002-9006	2	12	1/4" NPT Tip	004-T8004-PT	2
6	1/4" Braided Hose	002-9016	4	13	3/16" Lynch Pin	008-4576	2
7	1/4" Braided Hose-Blue	002-9016B	4	NP	Rubber Washer	004-1207W	2
				NP	Female Quick Connect	004-1207H	2

*Tip color subject to change

Complete Installation Kit 030-4536C
(Ref. 1-13)

Notes

Notes

Notes

Harvest Tec LLC. Warranty and Liability Agreement

Harvest Tec, LLC. will repair or replace components that are found to be defective within 12 months from the date of manufacture. Under no circumstances does this warranty cover any components which in the opinion of Harvest Tec, LLC. have been subjected to negligent use, misuse, alteration, accident, or if repairs have been made with parts other than those manufactured and obtainable from Harvest Tec, LLC.

Our obligation under this warranty is limited to repairing or replacing free of charge to the original purchaser any part that in our judgment shows evidence of defective or improper workmanship, provided the part is returned to Harvest Tec, LLC. within 30 days of the failure. If it is determined that a non-Harvest Tec branded hay preservative has been used inside the Harvest Tec applicator system where the failure occurred, then Harvest Tec reserves the right to deny the warranty request at their discretion. Parts must be returned through the selling dealer and distributor, transportation charges prepaid.

This warranty shall not be interpreted to render Harvest Tec, LLC. liable for injury or damages of any kind, direct, consequential, or contingent, to persons or property. Furthermore, this warranty does not extend to loss of crop, losses caused by delays or any expense prospective profits or for any other reason. Harvest Tec, LLC. shall not be liable for any recovery greater in amount than the cost or repair of defects in workmanship.

There are no warranties, either expressed or implied, of merchantability or fitness for particular purpose intended or fitness for any other reason.

This warranty cannot guarantee that existing conditions beyond the control of Harvest Tec, LLC. will not affect our ability to obtain materials or manufacture necessary replacement parts.

Harvest Tec, LLC. reserves the right to make design changes, improve design, or change specifications, at any time without any contingent obligation to purchasers of machines and parts previously sold.

Revised 5/22

HARVEST TEC, LLC.
P.O. BOX 63
2821 HARVEY STREET
HUDSON, WI 54016
PHONE: 715-386-9100
1-800-635-7468
FAX: 715-381-1792
Email: info@harvesttec.com