

Installation Manual

Model 644, 645, 650 & 651

25 & 55 Gallon Automatic Preservative Applicator



*Equipment and Products
for Quality Hay.™*

P.O. Box 63 • 2821 Harvey Street • Hudson, WI 54016
800-635-7468 • www.harvesttec.com

DECLARATION OF INCORPORATION



MANUFACTURER:

Harvest Tec LLC.
2821 Harvey St.
P.O. Box 63
Hudson, WI 54016, U.S.A.

REPRESENTATIVE ESTABLISHED IN COMMUNITY: Profitable Farming Company
Middle Barlington, Roborough
Winkleigh, Devon, EX19 8AG
ENGLAND

The person above certifies and declares that:

VIRTUAL MACHINE: Equipment mounted on a farm press and for the application of inoculants onto forage crops.

MODEL: 644,645,650,651-INST-17-Imp&Metric

BRAND: Harvest Tec

SERIAL NUMBER:

This application preservatives for hay Harvest Tec system meets the Directive 2006/42/EC of the European Parliament and the Council of 17 May 2006 and other applicable European Directives including Directive 2004/108/EC on the Electromagnetic compatibility.

The application of preservatives for hay Harvest Tec system will be turned on after being installed on a farm press has been declared in conformity with the Machinery Directive.

Person in the community authorized to provide information on the partly completed machinery and making this statement:

Richard Snell, President, Profitable Farming Company
Signed on May 21, 2011: Middle Barlington, Roborough
Winkleigh, Devon, EX19 8AG
ENGLAND

Harvest Tec 644, 645, 650 & 651 Installation Table of Contents

	<u>PAGE</u>
Introduction	4
Model Reference Chart	4
Tools Needed	4
Installation of Applicator	5-11
Installation of Tank & Mounting Brackets, Pump & Hose Manifold	5-9
Model 644	5-6
Model 645	7-8
Model 650	9-10
Hose Manifold (644, 645 & 650 only)	10
Model 651	11
Installation of Spray Nozzle Assembly	12-17
4415B-SO	12-13
4410B	14
4416B	14
4485B & 4502B	15
4506B & 4507B	16
Installation of iPad Integration Control	17
iPad Integration Control Lights	17
Bluetooth Receiver Lights	17
Installation of Dual Channel Processor (DCP)	18-19
Installation of Drain / Fill Line	19-20
Installation of Plumbing	21-22
Model 644, 645 & 650	21
Model 651	22
Installation of End of Bale Sensor	23
Installation of Stroke Counter Sensor	24-26
Model 651	24
Model 644 & 650	25
Model 645	26
Installation of Star Wheels & Bale Rate Sensor	27-28
Model 644, 645, 650 & 651 (Two Tie Only)	27
Model 650 (Three Tie Only)	28
Installation of Controls	29
Wiring Diagram	30
Pin Outs	31-32
Parts Breakdown	34-48
Model 644 Base Kit	33
Model 645 & 650 Base Kit	34
Model 651 Base Kit	35
Pump Plate	36
Star Wheels, Bale Rate Sensor, Hose Assembly, Drain Fill Kit	37
Control Boxes and Wiring Harnesses	38
Model 4410B	39
Model 4415B-SO	40
Model 4415B	41
Model 4416B	42
Model 4417B	43
Model 4485B	44
Model 4502B	45
Model 4506B	46
Model 4507B	47
Optional iPad Mounting Kit	48
Optional iPad Display Kit	49
Star Wheel Installation Guide	50
4415 Spray Shield Guide	51-52
Notes	53-54
Warranty Statement	55

Introduction

Thank you for purchasing a Harvest Tec Model 662 Hay Preservative Applicator. This 662 applicator system has been designed to operate through an Apple iPad (not included) using the Hay App. As well as plug directly into most tractors that have an ISOBUS Monitor. The 662 Applicator System offers these advantages by operating through an Apple iPad:

1. Large bright, clear, colorful display
2. More durable and can be read in bright sunlight
3. Can be used for multiple other uses than just the applicator display
4. Option to tie-into the tractor ISOBUS system

The 662 Hay Preservative Applicator System is designed to apply buffered propionic acid to the forage crop as it is baled and will adjust the rate of application based on moisture and tonnage of the crop being harvested. This manual will take you through the steps for installing the applicator. If you are unsure about installing the system after consulting this manual, contact your local authorized dealership for additional assistance. For your convenience a parts breakdown is located in the back of this manual, contact your local authorized dealer to order the parts. This applicator is designed to apply Harvest Tec buffered propionic acid.

***Made for iPad® running the current iOS operating system
or one version previous required for iPad option**

*iPad is a trademark of Apple Inc., registered in the U.S. and other countries.

****600 Series Applicators with serial number before DCP27000 will require the DCP to be sent to Harvest Tec for a required update in order to use the iPad Integration Module (030-6672C).**

*Hay App version must be **at least 2.7.1 (or higher)** to operate with the iPad Integration Module

Model Reference Chart

<u>Baler Make</u>	<u>Baler Model</u>	<u>Model Number</u>	<u>Install Kit</u>
CASE IH	SBX530, SBX540, SBX550, SB 531 – SB 551	651	4415B
NEW HOLLAND	570, 575, 580 & BC 5060 – BC 5080	651	4415B
MASSEY FERGUSON	1835, 1836, 1837, 1838, 1839, 1840, 1841, 1842 (TANK TOP MOUNT)	644	4416B
MASSEY FERGUSON	1835, 1836, 1837, 1838, 1839, 1840, 1841, 1842 (TANK SIDE MOUNT)	644	4417B
CASE IH	2001 AND OLDER SQUARE BALERS (TWO TIE)	650	4485B
HESSTON, MASSEY NEW IDEA, AND CHALLENGER	ALL CONVENTIONAL SQUARE (TWO TIE) BALERS	650	4485B
HESSTON, MASSEY NEW IDEA, AND CHALLENGER	ALL THREE TIE BALERS	650	4502B
FREEMAN	ALL THREE TIE BALERS	650	4506B
NEW HOLLAND	BB 900 & 585	650	4507B
JOHN DEERE	ALL SMALL SQUARE BALERS	645	4410B

Tools Needed

Standard wrench set	Metal drilling and cutting tools
Standard socket set	Center punch
Standard screw driver or 5/16" nut driver	Tape measure
Side cutter	Hose cutter
Crescent wrench	Straight edge
1 1/2" hole saw	Hammer

Installation of Applicator

Installation of Mounting Brackets, Pump Manifold, Hose Manifold and Tank

Model 644

Tank legs will be mounted to the back side of baler behind knotters and before the bale tensioner (figure1).

Using figure 2 as a reference, mark the two holes on each side of bale chamber that need to be drilled. Line up saddle leg on each side to verify holes before drilling, show in figure 3. Drill four holes to 1/2" (13mm).

Bolt legs to baler with 1/2" x 1 3/4" Allen button head bolts, flat washer, Lock washer, and nuts.

*Note: bolt head is on inside of bale chamber. Level top of leg before completely tightening bolts, figure 4.

Bale Thrower - Additional Bracket

When baler is equipped with a bale thrower, bracket (001-4703QC) will need to be used. First secure the kicker so it will not rotate when you remove the front pin on the hydraulic cylinder. Remove pin, Install tank leg over mount. Reinstall pin. Use part 001-4703QC which is a spacer that will go between the leg and side of the baler to take up the space the throwers front hydraulic mount adds.



Figure 1



Figure 2

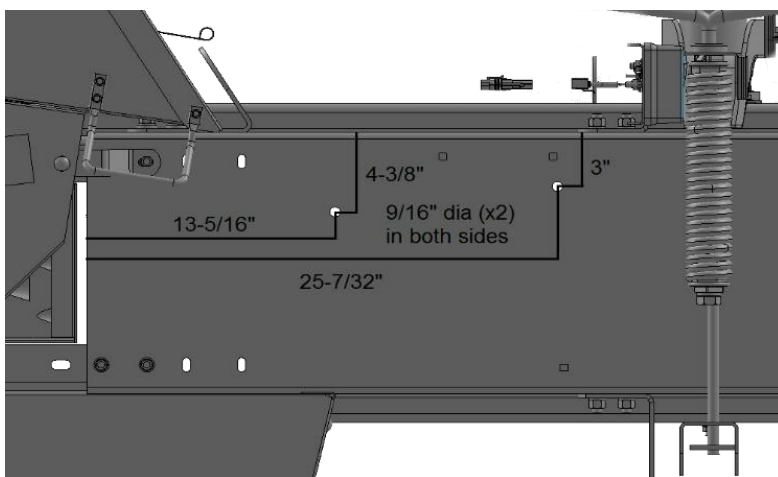

Figure 3



Figure 4

Model 644 (continued)

Saddle & Tank

Mount tank saddle (001-4703X) onto tank legs as shown in figure 5. Bolts are pre-installed on saddle, secure with 1/2" locks, washers, and nuts.



Figure 5

Massey 1800 Series Side Mount Tank Mounting Instruction

1. Lay tank and frame assembly on ground next to bale chute on right side of baler.
2. Locate "U" bolts (001-4703QUB) and install them around center hitch tube of baler. Attach to legs of tank frame. Do not fully tighten down nuts. **Note:** Tube is not parallel to the ground so you will need to offset "U" bolts in frame (001-4703QS).
3. Rotate tank assembly up and check to see if saddle is parallel to ground. If not adjust holes "U" bolts are installed into.
4. Install rear mount (001-4703QU) just in front of "U" bracket on bottom of the bale chamber. You will need to drill 9/16" holes 13 1/2" from rear of bale chute. Secure to baler with two 1/2" x 1 3/4" BHSC bolts Locks and nuts.
5. Slide tank and saddle frame on pipe to match up with rear mount (001-4703QU) Install two 1/2" x 1 1/4" bolts, flat washers, lock washers and nuts.
6. Place second mount (001-4703QU) on front leg of tank saddle and mount to baler the same way as rear mount.
7. Check frame again so it is parallel to ground. Tighten down all bolts fully.
8. Attach pump.
 - a. For Electronic and manual systems mount pump on rear of saddle.
 - b. For Automatic systems mount pump plate to outside edge.

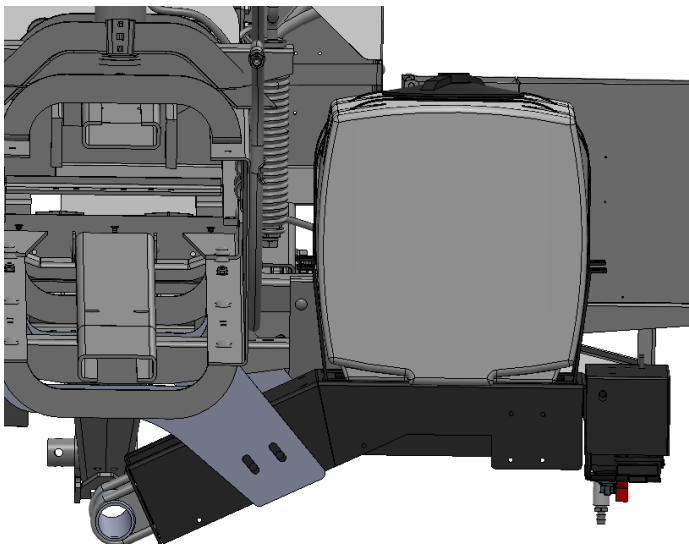

Model 644 (continued)

Pump Manifold 644

Locate parts bag 8. Using two 3/8" x 1/4" bolts, locks, washers, and nuts. Mount the U shaped pump plate mount 001-4647 (right) onto the tank saddle in the mounting holes located between the strap brackets on back of saddle (figure 7).



Connect the pump plate mounting bracket (001-4646C), shown in figure 8, using two 3/8 x 1 1/4" bolts, nuts, locks, and flat washers to the mounting bracket. Install the rest of the pump plate as shown in figure 9. Attach the pump plate holder (001-4646D) to pump plate mounting bracket (001-4646C) using four 3/8" x 3/4" flange head bolts.

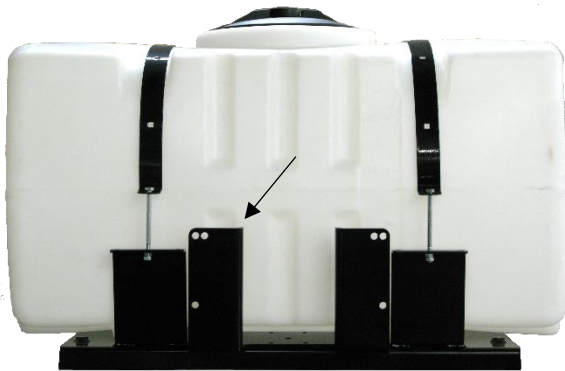

Figure 7

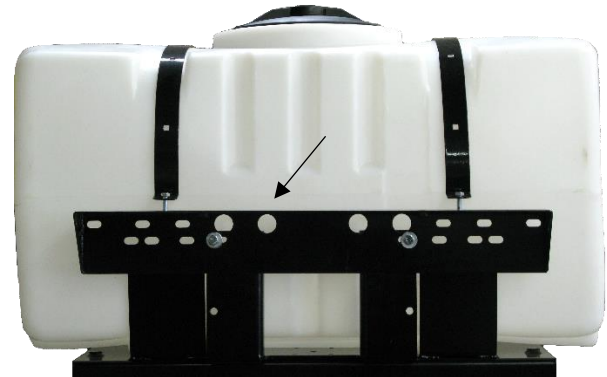

Figure 8

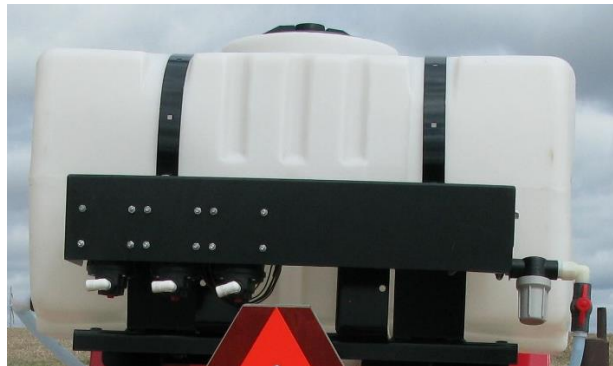

Figure 9

Model 645

Mount the unit on the diagonal frame behind the twine box, as pictured (Figure 8) using the base clamp (001-4406) and u-bolts (001-4406A). Locate the top reach rod (Figure 9) in a position opposing the overhanging tank. Bolt one end to the top stub pipe on the tank saddle and the other end to a secure location on the baler. **NOTE: REACH RODS MAY HAVE TO BE BENT ON THE TAB TO ALIGN PROPERLY.**



Figure 8

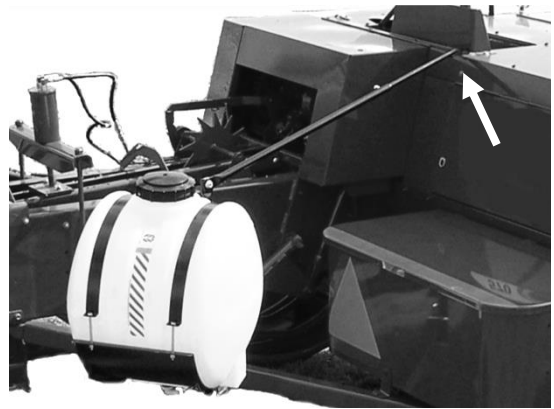

Figure 9

A. Recommended Mount

The U shaped bracket (001-4647) will already be attached to the saddle and will need to be inverted to fit on the bottom of the saddle as shown in Figure 10. Reattach the bracket to the bottom of the saddle using the four 1/4" x 1 bolts, nuts, flats and lock washers. Connect the pump plate mounting bracket (001-4646C), shown in Figure 11, using two 3/8" x 11/4" bolts, nuts, locks, and flat washers to the U shaped bracket (001-4647). Install the rest of the pump plate as shown in Figure 12. Attach the pump plate holder (001-4646D) to pump plate mounting bracket (001-4646C) using four 3/8" x 3/4" flange head bolts.

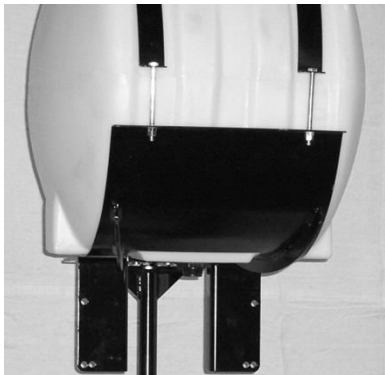

Figure 10

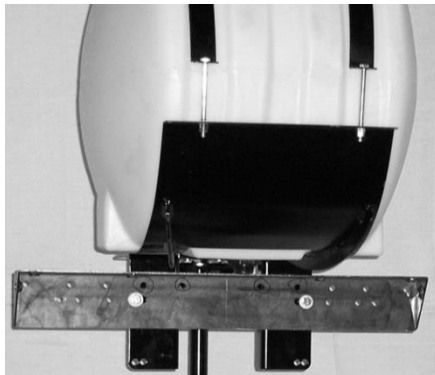

Figure 11

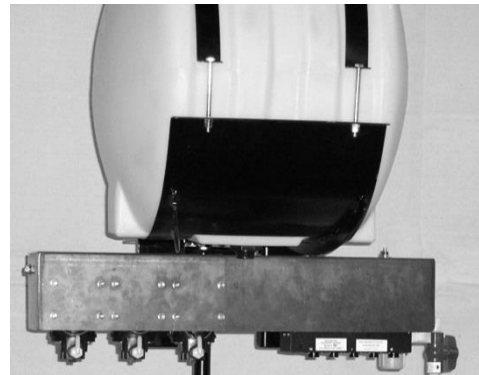

Figure 12

Model 645 (continued)

B. ALTERNATE LOCATION FOR GROUND CLEARANCE

The U shaped bracket (001-4647) will already be attached to the saddle as shown in Figure 13. Connect the pump plate mounting bracket (001-4646C), shown in Figure 14, using two 3/8" x 1 1/4" bolts, nuts, locks, and flat washers to the U shaped bracket (001-4647). Install the rest of the pump plate as shown in Figure 15. Attach the pump plate holder (001-4646D) to pump plate mounting bracket (001-4646C) using four 3/8" x 3/4" flange head bolts.



Figure 14

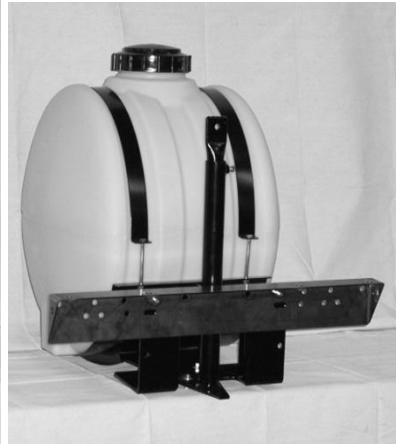

Figure 15

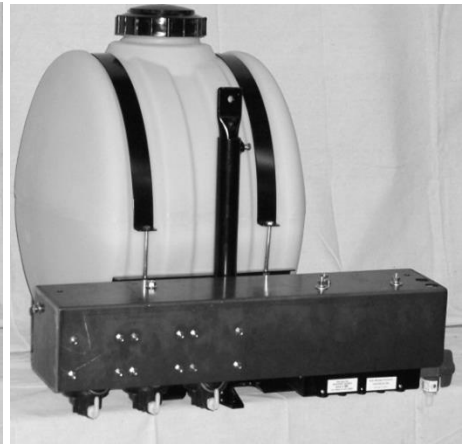

Figure 16

Model 650

Attach legs part #001-4703B to the tank saddle with 3/8"x 1" bolts, flat and lock washers. The legs will attach on top of the bale chamber in front of the hydraulic compression area (Figure 2). You will need to drill four 1/2" (13mm) holes on top of the chamber to mount the tank and frame. Clamp legs on top of the bale chamber, mark the holes and drill. The 1/2" x 1 3/4" inch allen head carriage bolts will be inserted through the bale chamber along with flat washers so that the carriage head will be inside of the chamber. Secure the allen head carriage bolts with 1/2" nuts, flat and lock washers. Mount the supplied support bracket to the bottom of the tank saddle and to the baler frame (Figure 3)

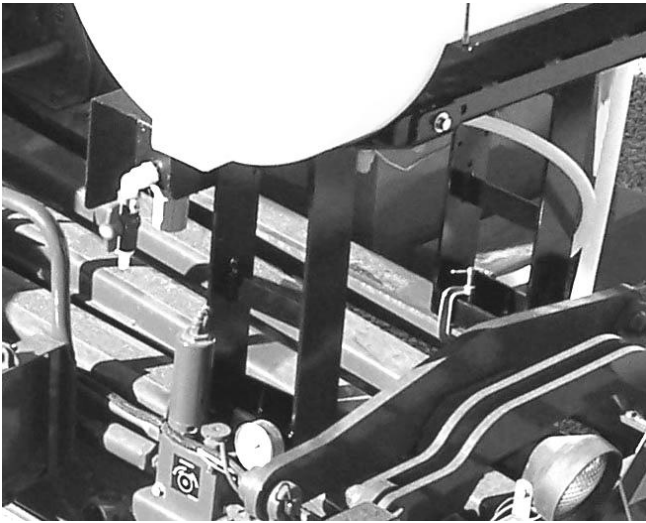

Figure 2

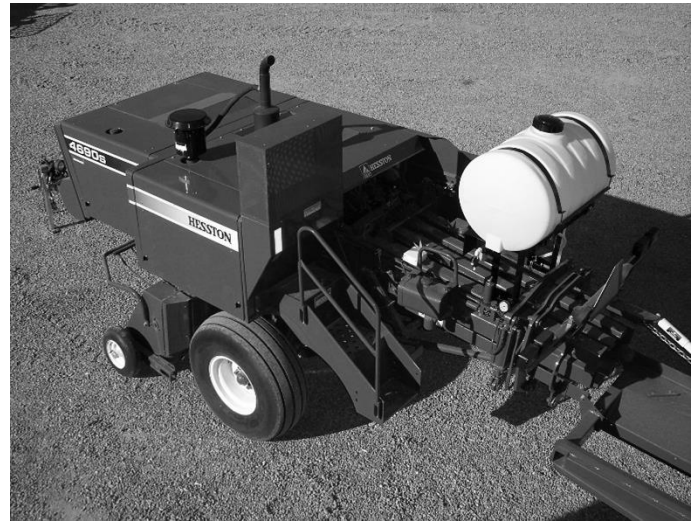

Figure 3



Figure 4

Mount support bracket (001-4424C) at these locations.
Two tie models only.

Model 650 (continued)



Figure 5

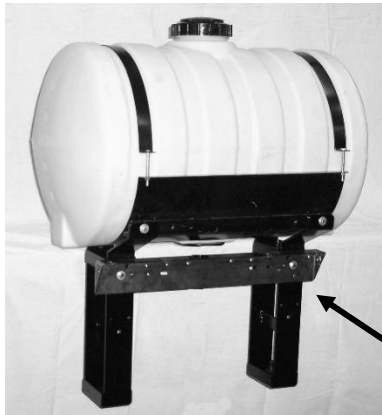

Figure 6



Figure 7

1. Locate the two mounting holes as shown in Figure 5.
2. Connect the pump plate mounting bracket (001-4646C), shown in Figure 6, using two 3/8" x 1 1/4" bolts, nuts, locks, and flat washers to the saddle.
3. Attach the pump plate holder (001-4646D) to pump plate mounting bracket (001-4646C) using four 3/8" x 3/4" flange head bolts shown in Figure 7.

Hose Manifold Model 644, 645 & 650

Mount the hose bracket on the front of the baler in the area of the spray shield. Make sure the bracket will not interfere with any baler operations. Shown below in Figure 16.

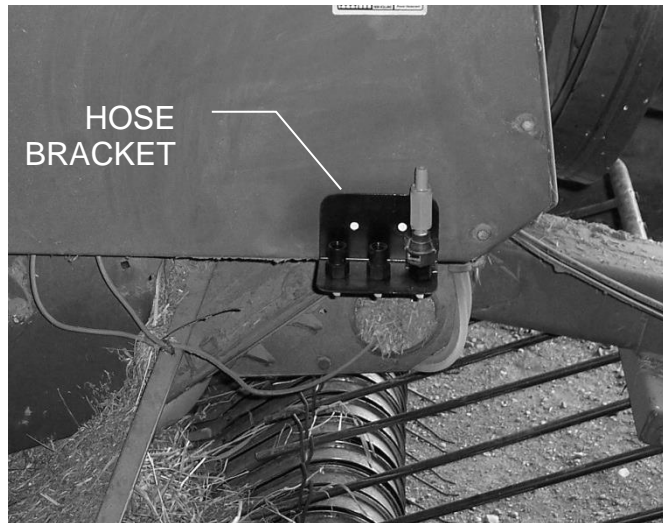

Figure 16

Model 651

Mount the two long strap bases (001-4703CD) to the bottom side of the saddle (001-4703C) front edge. Note: This is the side that has a 2" diameter hole in one of the sides. Use four 3/8" x 1 1/4" bolts, washers, locks, and nuts to secure. Mount the two short bases (001-4703CC) to the bottom side of the saddle's back edge. Use 3/8" x 1 1/4" bolts on the outside holes. Leave the inside holes open for the installation of the pump plate mount.

Install the "U" shaped pump plate mount (001-4647) to the top and back edge of the saddle. Secure with two 3/8" x 1 1/2" bolts on the outside that also go through the short mounting bases as listed above. Place one 3/8" x 1 1/4" bolt in the middle. Secure with washers, locks and nuts.

Install the tank fitting into the bottom of the tank (003-EL3412) and mount the tank on top of the saddle and between the strap bases. When facing the front of the tank, make sure the side tank fitting is on left.

Locate the two straps (001-4402). Position the straps over the top of the tank and secure with four 5/16 x 4 1/2" bolts and eight nuts. All of the strap bolts need to have double nuts. Mount the door strap (001-4703CL) on a back strap base using the 1/4 x 1 1/2" bolt, two washers and nylock nut.

Connect the pump plate mounting bracket (001-4646C) using two 3/8" x 1" bolts, nuts, locks, and flat washers to the U shaped bracket (001-4647). Attach the pump plate holder (001-4646D) to pump plate mounting bracket (001-4646C) using four 3/8" x 3/4" flange head bolts.

Mount the tank as shown below. The tank will be mounted as far to the right side of the baler as possible. The side tank fitting will be facing the right side of the baler. The pump plate assembly will be at the back of the baler. Place the tank on top of the baler and open the front access door. Position the tank so that the front access door can be lifted open and locked in place. Line up the side of the tank saddle closest to the plunger with the bolts on top of the hood. Remove the two bolts, line saddle up with existing holes, and secure with new M8 x 30mm bolts, flat washers, and locks. The back access door will be held open with the door strap. Mark and drill two 3/8" (10mm) holes on the top of the baler for the other open holes in the saddle to attach, secure with two M8 x 30mm bolts, locks, flats, and nuts. Before drilling, verify that the hole placement will not interfere with any baler operation.

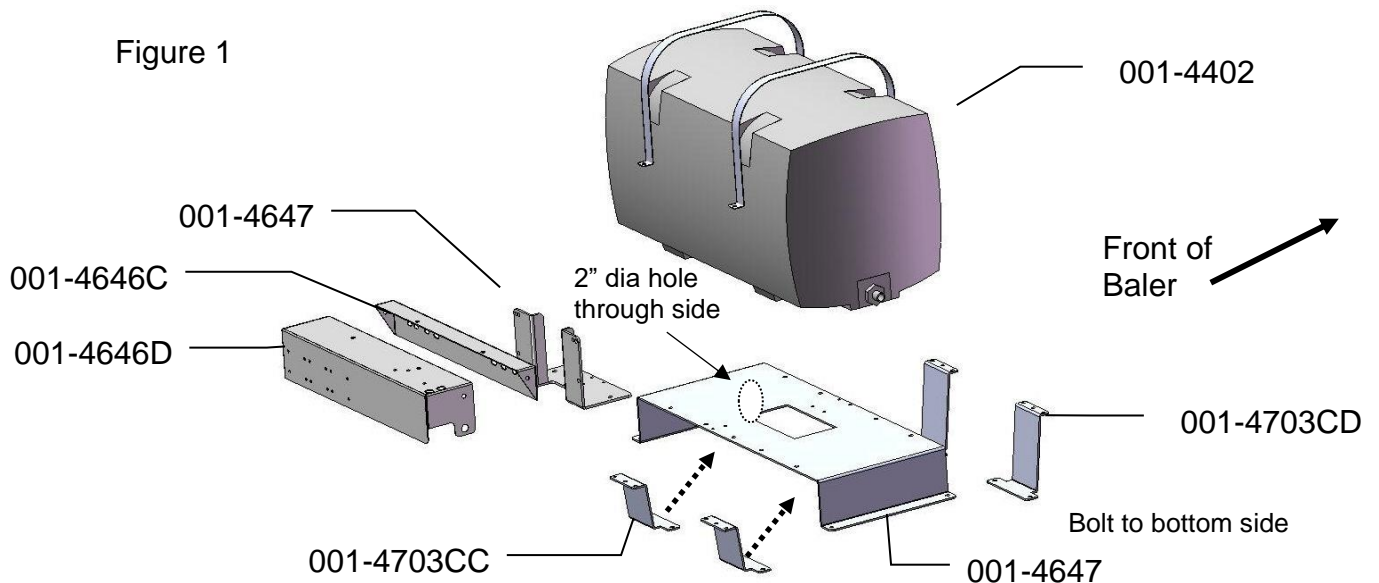

Installation of Spray Nozzle Assembly

Install kit 4415B-SO

Locate the hay guard directly above the bale chamber. This install can be done with the hay guard in the baler, but it is recommended to remove. Consult your dealer for procedure.

Installation of spray shield

1. Mark a point 10" (25cm) from the knife and centered on the hay guard. Next, mark a point 20" from the knife and centered on the hay guard. Using a straight edge draw a line between these two points.
2. Locate the template in the back on the manual. Align the template accordingly with the centerline and the correct side pointing towards the knife. The first point will align on the 10" mark from the knife. Tape the template to the hay guard following the centerline.
3. Center punch all five of the points on the hay guard. Verify measurements with template.
4. Remove the template and mark the center-punched points 1 through 5 starting at the point closest to the knife.
5. Drill all five holes with an 1/8" drill bit **ONLY THROUGH THE TOP PIECE OF STEEL.**
6. At points 2, 3, and 5 drill only through the top of the hay guard with a 1 1/2" hole saw.
7. Drill points 1 and 4 through both the top and bottom steel using a 1/4" drill bit.
8. Insert two 1/4" x 2" button head cap screws through holes 1 and 4. The head of the screw will need to be down (in the chamber). Secure with nylon lock nut.
9. Place spray shield with plastic fittings down onto the hay guard. Secure with 1/4" flat washers and nut. Turn the white nylon fittings down until they touch the bottom of the hay guard. These fittings will be used as drill guides.
10. Drill through the bottom steel on holes 2, 3, and 5 with a 1/4" bit. Remove the shield and drill the holes with a 9/16" bit. Be careful to not oblong the holes. De-bur any metal filings left around the three holes on both sides of the hay guard.
11. Remove plastic drill guides from the shield and replace with the elbow fittings. Place the check valve, tip and cap onto the end of the elbow.
12. Thread the elbow with the blue tip into the low threaded hole on the shield. The medium will be the green tip, followed by brown at the high threaded hole. Do not thread all the way down, only start the elbows.
13. Place the shield on the hay guard and secure by pressing down. Thread all three elbows down until they touch the bottom metal.
14. Secure the spray shield with the knobs.

Installation of hose and support bracket

1. If the hay guard was removed for shield installation reinstall at this time.
2. Mark a point 6" (15cm) from the first rotating tine on the center of the hay guard. Center punch this mark and drill a 1/4" hole through both top and bottom of the hay guard.
3. Bolt the bottom bracket (001-4425B) using 1/4" x 2" button head cap screw. Secure with a 1/4" flange nut. The head will need to be down (in the chamber).
4. Loosely install the remaining bracket (001-4425B) to the bottom bracket attaching in the middle. Level the two pieces and extend the top bracket until it reaches the top of the baler. Secure with a 1/4" flange bolt and nut.
5. Mark and drill the top hole with a 1/4" bit. Secure with a 1/4" flange bolt and nut.

Installation of hose and support bracket (continued)

6. Cut a 1 1/2" (38mm) hole in the top of the baler for the hose to route through. Install the grommet once the hole is complete.
7. Secure the low and medium hoses on the end of the spray shield with two jiffy clips (008-9014) and a 1/4" x 1/2" round head screw.
8. Install the hose from the shield under the hay tine, to the bracket, and out the top.
9. Secure the hose to the bracket with two jiffy clips (008-9009) and 1/4" flange bolts and nuts.
Keep the hose in the center of the bracket.
10. Install the hoses on to the correct pumps. See plumbing section (pg 17).

Figure 17

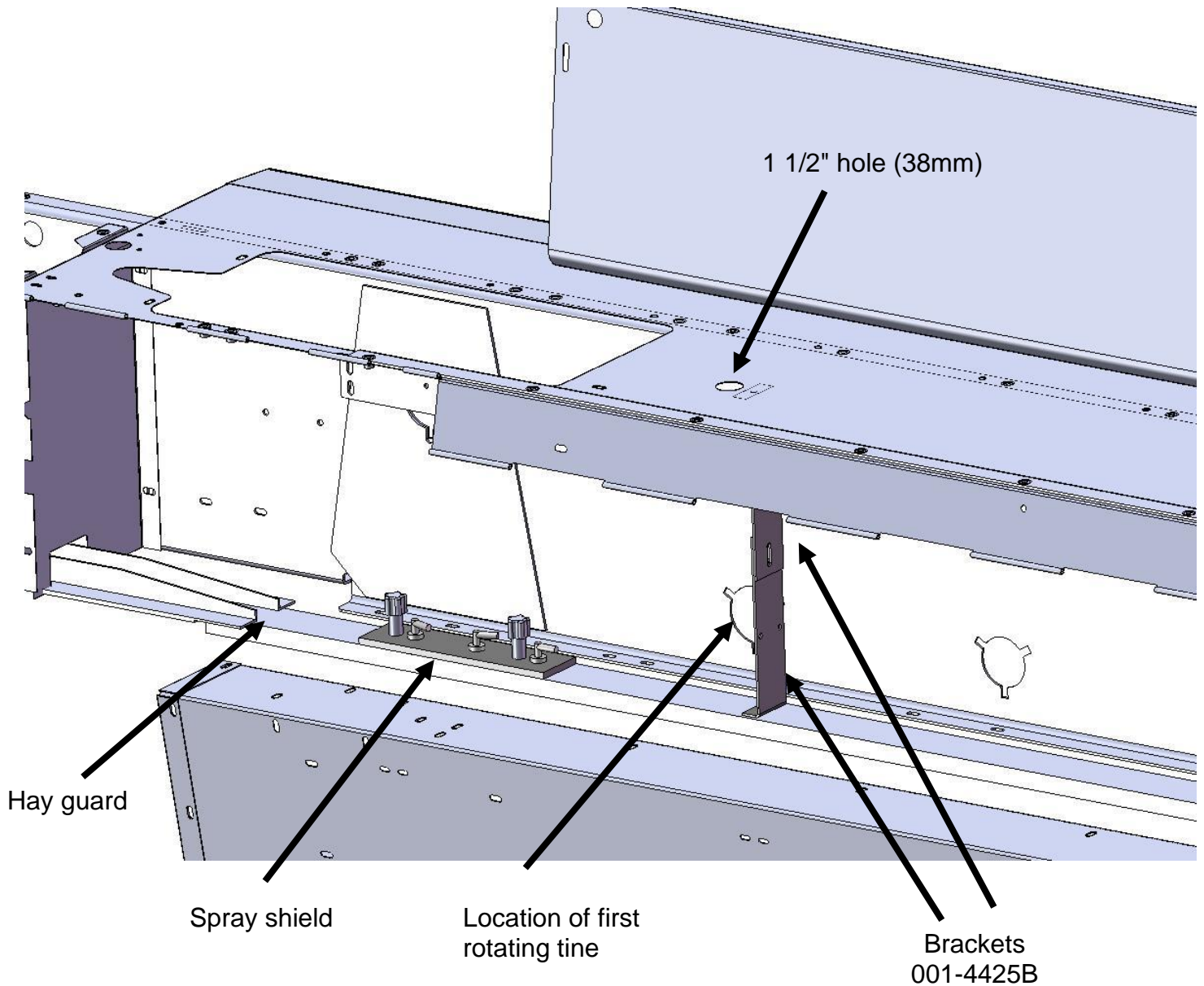

View from behind the twine box with the inspection door open.

Install kit 4410B

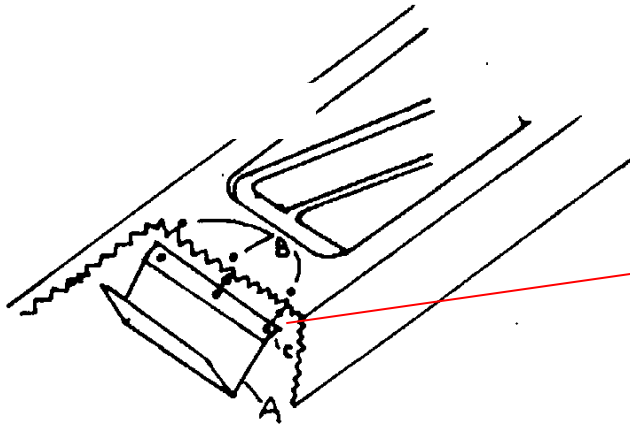

Install hoses before installation of shield. Bolt the nozzle holder up under the baler's hood. Remove 3 bolts on the baler and replace with hardware in kit to fasten lip securely in place. Three 1/4" lines will need to be run from the hose manifold to the spray shield. Use the color-coded stickers to attach the correct hose to the correct tips, and couplers. Secure the lines to the bracket and spray shield using the supplied hose clamps (above).

Install Kit 4416B & 4417B

On baler tongue above center of the baler (figure A), install spray shield holders (001-4424B) on both sides of tongue using pre-drilled holes (figure B). Securing each with one 3/8" bolt. Do not tighten bolts. Place the spray shield (001-4424A2) on the shield holders using two 3/8" bolts, washers, lock and nuts. Spray shield should spray toward back of pickup, between augers, in area before crop enters baler (figure C). When angle of tips is correct, tighten shield holder bolts. Route hose to hose manifold.



Figure A



Figure B



Figure C

Install kit 4485B



Figure 18



Figure 19

Install spray shield (001-4424B) on baler as shown in the above figures. Use the two existing holes shown in Figure 18 and one existing hole shown in Figure 19 to attach the spray shield.

Install kit 4502B

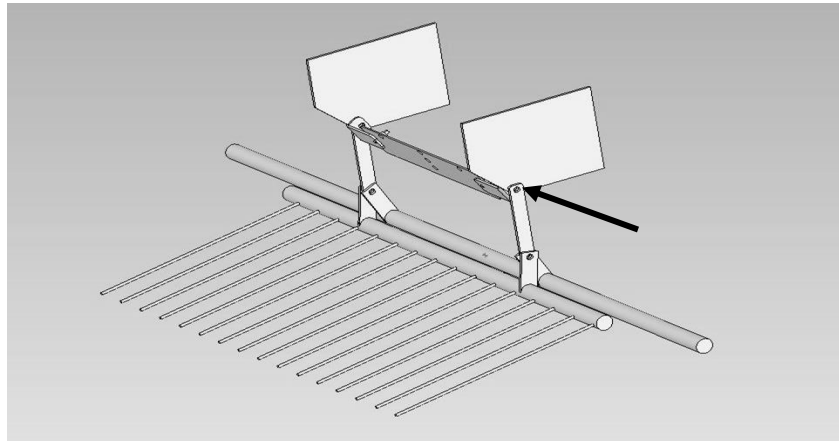
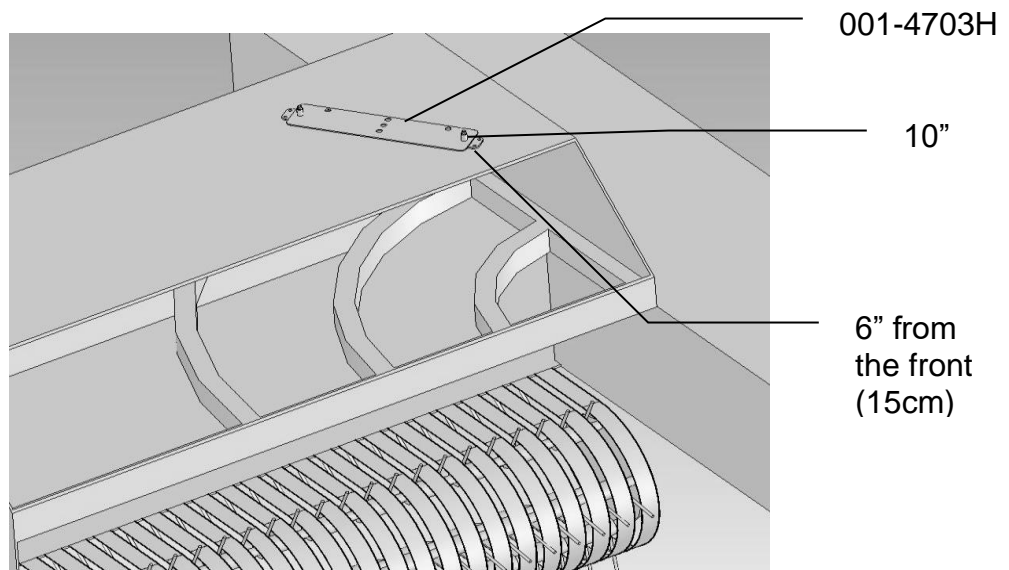

Figure 20

The shield for your baler will mount in the throat of the baler as shown above. Remove nut and bolt on both sides of baler (Figure 20). Install shield holders (001-4703I) with 1/2" x 2" bolts, nuts, locks and flat washers. Do not tighten these bolts until the shield is properly aimed. Aim the shield at bottom of the pickup head at the point where stuffer fingers connect with hay (between the two augers) and make sure the bushing is not removed. Once the shield is in place the nuts may be tightened down.

Install kit 4506B

Figure 21



The shield for your baler will mount on top of the sheet metal directly above the pickup head shown in the picture above (Figure 21). Mount shield holder (001-4703H) on top of metal 6" (15cm) from the front of the baler and 10" (25cm) from the side of the baler. Attach this holder with 1/4" x 1 1/4" self-tapping bolts. Place shield of top of holder and rotate the shield to a 45-degree angle. Mark the location of the next holder's position and install. Four holes will need to be drilled below the tips using a 3/4" hole saw or bit.

Install kit 4507B

Figure 22

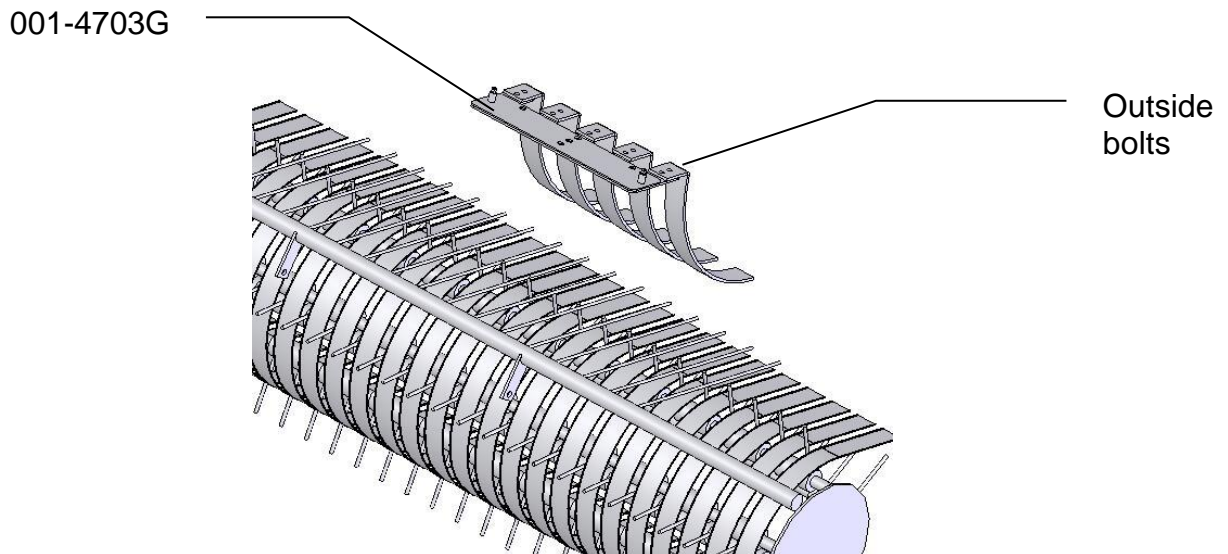

The shield for your baler will mount on the wrap guard as shown in the picture above (Figure 22). Remove the two outside bolts on each side of the wrapper guard. Place bracket 001-4703G so pins are facing up and bolt through with 3/8" x 1 1/2" into bracket 001-4703G, through wrap guard, and into threaded holes on baler frame that the bolts were removed from.

Installation of iPad Integration Control

Locate a safe location in the cab of the tractor to place the iPad Integration Control (030-6672C). Recommended location is securely fastened out of the operators way in a location that is close enough to reach with the iPad cord.



Connect the Power / Communication harness (006-6650TM(E)) to the bottom of the receiver.

To operate the applicator, plug the iPad cord into the communication port indicated by:

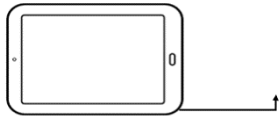

iPad Integration Control Light Signals

Green Slow Blink – Power supplied to the applicator system and the unit is going through its startup process. This will take approximately 25-35 seconds.

Green Double Blink – Indicating the iPad module recognizes the iPad but the app is not open or connected.

Green Solid Light – Module is connected to the app and is ready to operate.

*Recommended to use the USB cable included with the applicator kit (006-6672USBC)

Bluetooth Receiver Lights

Pre-2020 applicators equipped with Bluetooth receivers (030-6672B) are now equipped with lights to indicate both power and Hay App connection on the Apple iPad. Clean light regularly

Blinking Lights – System is waiting for the processor to connect, which could take up to 35 seconds.

Red Light – The Bluetooth receiver has power

Green Light – The Bluetooth receiver is connected to the Hay App.



****600 Series Applicators with serial number before DCP27000 will require the DCP to be sent to Harvest Tec for a required update in order to use the iPad Integration Module (030-6672C).**

Hay App version must be **at least 2.7.1 (or higher)** to operate with the iPad Integration Module

*Made for Apple iPad badge

Use of the Made for Apple iPad badge means that an accessory has been designed to connect specifically to the Apple product(s) identified in the badge and has been certified by the developer to meet Apple performance standards. Apple is not responsible for the operation of this device or its compliance with safety and regulatory standards.

Please note that the use of this accessory with an Apple product may affect wireless performance.

Installation of Dual Channel Processor (DCP)

Model 644

The DCP (006-6671SS) will mount in the pre-drilled holes on the left saddle leg (below). Secure the DCP using four 5/16" x 1" bolts, locks, flats, and nuts. Install the DCP with power plug facing down.



Model 645 & 651

The DCP (006-6671SS) will mount on the back of the twine box. Mark and drill four 5/16" (8mm) holes and secure the DCP using four 5/16" x 1" bolts, locks, flats, and nuts. Install the DCP with power plug facing down.

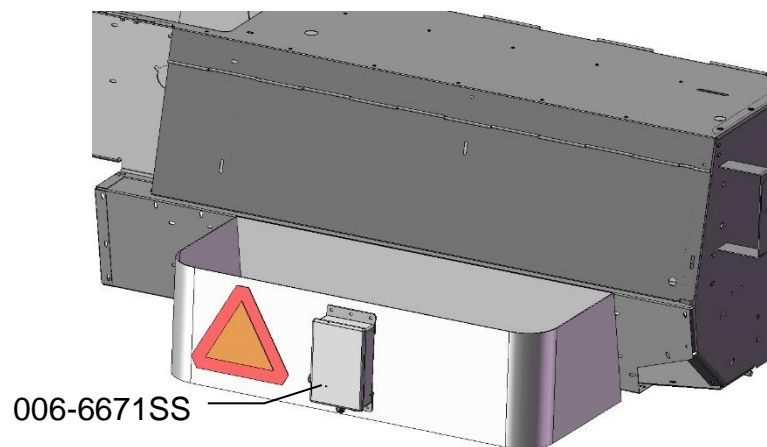

Figure 24

View from back of baler

Model 650

The DCP (006-6671SS) will mount on the right saddle leg. Install the two DCP mounts (001-4703BPM) to the leg using two 5/16 x 1 bolts, locks, and nuts. Install the DCP to the mounts using four 5/16" x 1" bolts, locks, flats and nuts. Install the DCP with the power plug facing down.

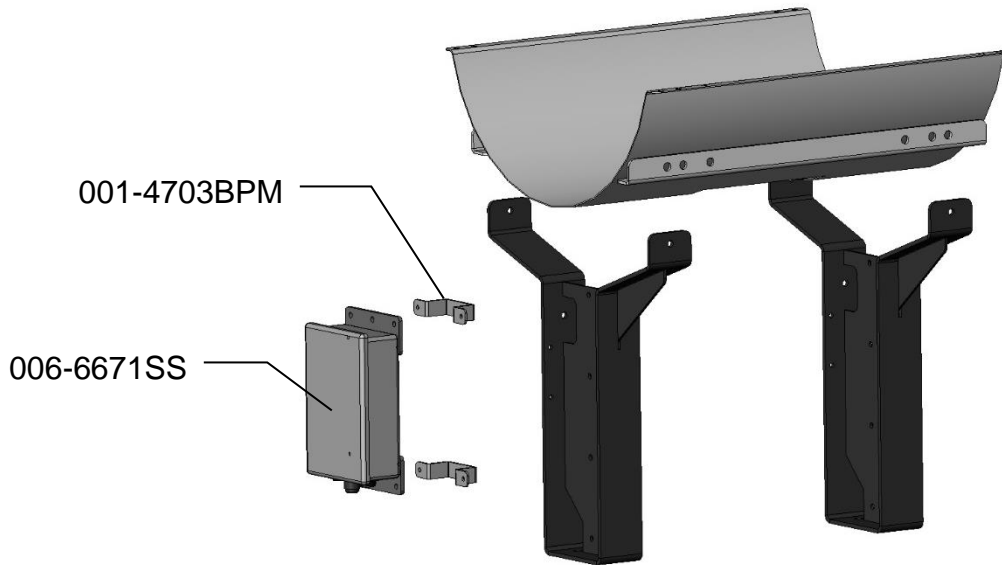

Figure 25

Installation of Drain / Fill Line

Model 644

Using parts bag 1, locate the pre-drilled hole at the front of the bale chamber (figure A). Secure valve assembly to baler using 5/16" x 3/4" carriage bolts (figure B). Thread 3/4" elbow fitting into tank, cut hose to correct length and connect to valve assembly. Secure with hose clamps on both ends (figure C).

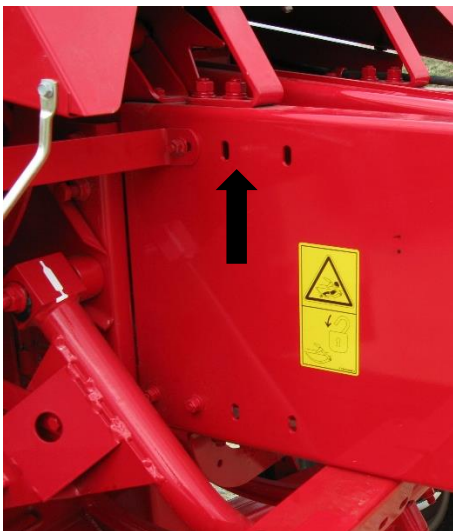

Figure A



Figure B



Figure C

Model 651

Install the straight fitting (003-A3434) or elbow fitting (003-EL3434) into the side fitting in the tank (Figure 26). Drill two 5/16" (8mm) holes using the valve holder (001-6702H) as a template on the right side of the baler above the tire. Mount the valve holder with two 1/4" x 1" bolts, locks, flats and lock washers. Attach the 3/4" cam coupler to the 3/4" ball valve through the valve holder. Insert the straight fitting (003-A3434) into the ball valve. Cut the 3/4" hose to length secure on both sides using hose clamps.

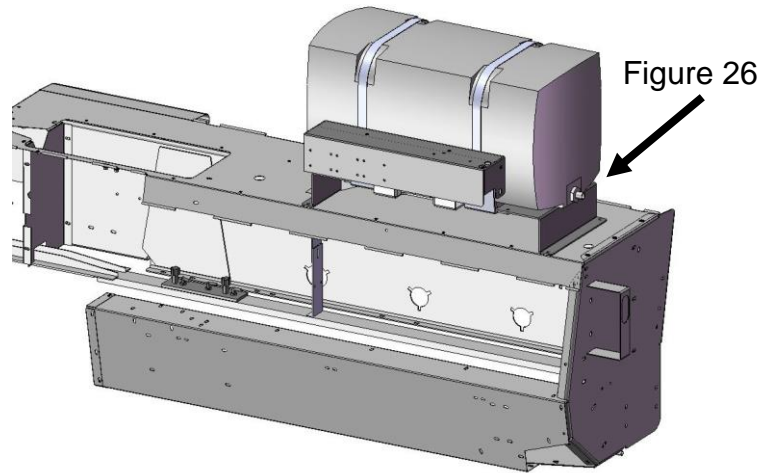

Model 650

Thread 3/4" elbow fitting into end of tank. (003-EL3434) Run 3/4" hose from the elbow down the frame to the bottom of the baler (Figure 27). Drill 1/4" (7mm) holes to accept the valve holder bracket and use 5/16" x 1 1/4" self-tapping screws. Connect valve assembly to other end of hose. Place hose clamps on both ends. Secure hose to frame using cable locks.



Figure 27

Installation of Plumbing

Model 644, 645 & 650

A. Intake

Use the 003-EL3412 on the bottom of the tank to route 1/2" line (002-9001) to the 003-A1212 fitting on the ball valve already attached to the pump plate. Attach hose clamps (003-9003) on both of the fittings.

B. Discharge

The three-1/4" hose assembly will be used to attach the pumps to the hose manifold (Figure 19). Use color-coded stickers to attach the clear, green, and blue hoses to proper pumps and couplers on the hose manifold. The same color-coded stickers will be used to attach the hoses from the hose bracket to the spray shield. (Pump 1 clear/white, Pump 2 green, Pump 3 blue.)

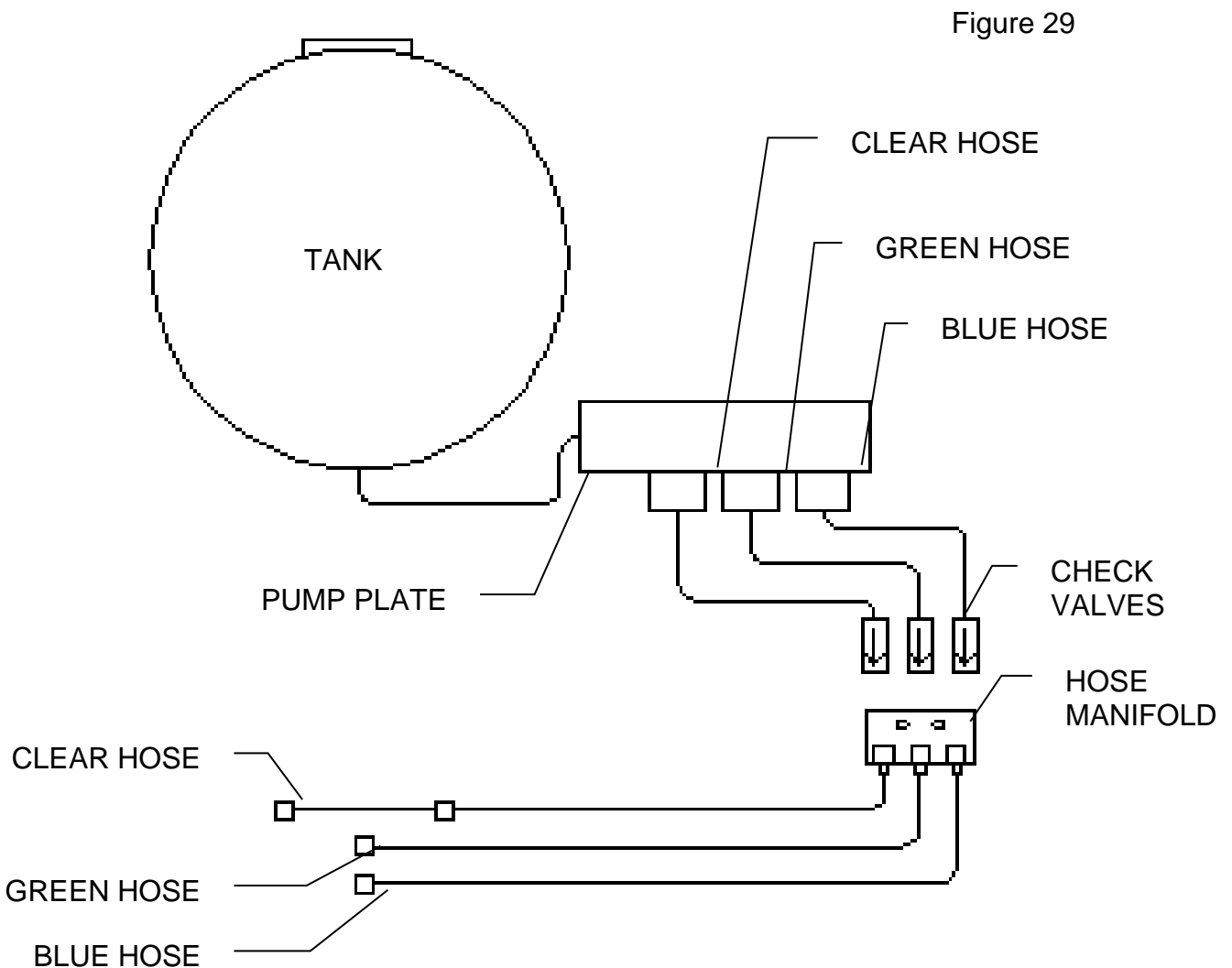

Model 651

A. Intake

Use the 003-EL3412 on the bottom of the tank to route 1/2" line (002-9001) to the 003-A1212 fitting on the ball valve already attached to the pump plate. Attach hose clamps (003-9003) on both of the fittings.

B. Discharge

The three-1/4" hose assembly will be used to attach the pumps to spray shield. Use the color-coded stickers to attach the clear, green, and blue hoses to the proper pumps and elbows on the spray shield. (Pump 1 clear/white, Pump 2 green, Pump 3 blue.) Leave slack in the hoses to allow the back door on the baler to open for service (Figure 28).

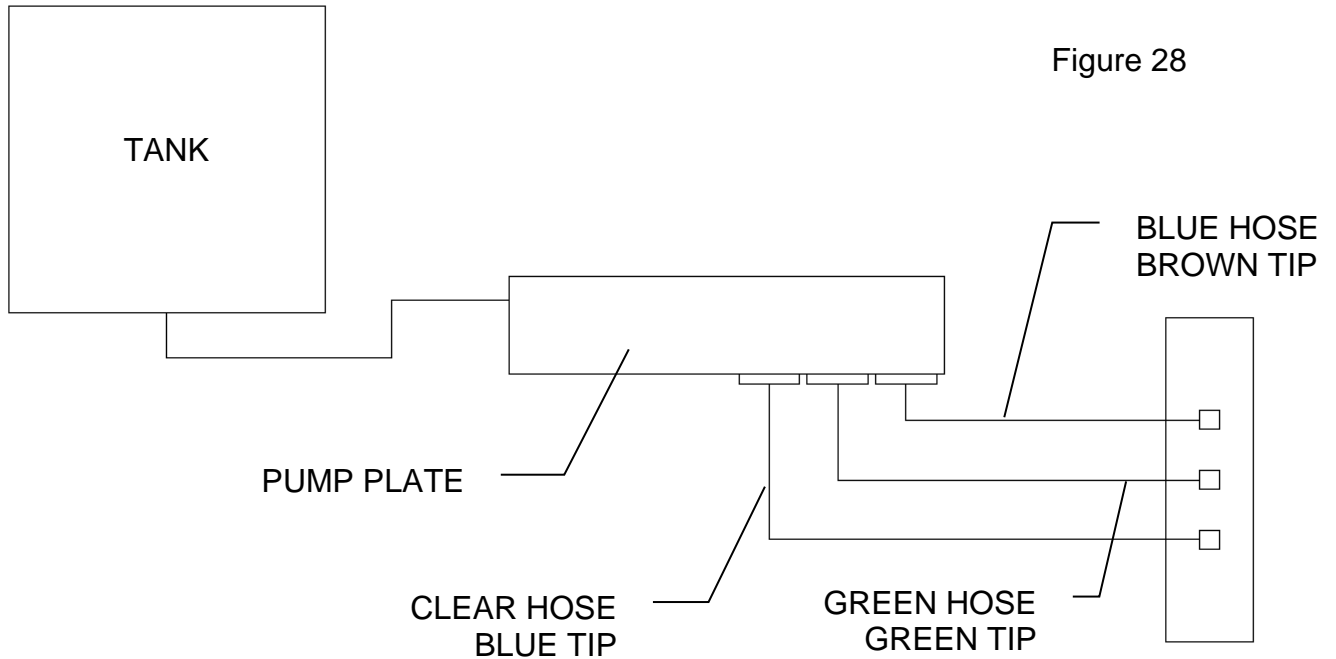

Installation of End of Bale Sensor

The end of bale sensor determines the position of the needles on the baler. When the needles cycle, the sensor communicates this information to the Dual Channel Processor. This information is used for job records and will be used by the optional Bale Identification system. Follow the steps below for your baler to mount the sensor.

Mount the 006-7400 sensor to the mounting bracket 001-4648SS for Case IH, New Holland, & John Deere or 001-4648SI for AGCO as shown below. Figure 30

Mount the assembly on the right side of the baler chamber. The face of the sensor needs to be parallel to the arm attached to the needles (Figure 31). Mark and drill two 3/8" holes. Install the sensor using two 5/16" x 1" allen head bolts, locks, and nuts. The end of the sensor needs to be no greater than 1/4" (7mm) away from the needle arm. Tighten both nuts on the sensor after the adjustment.

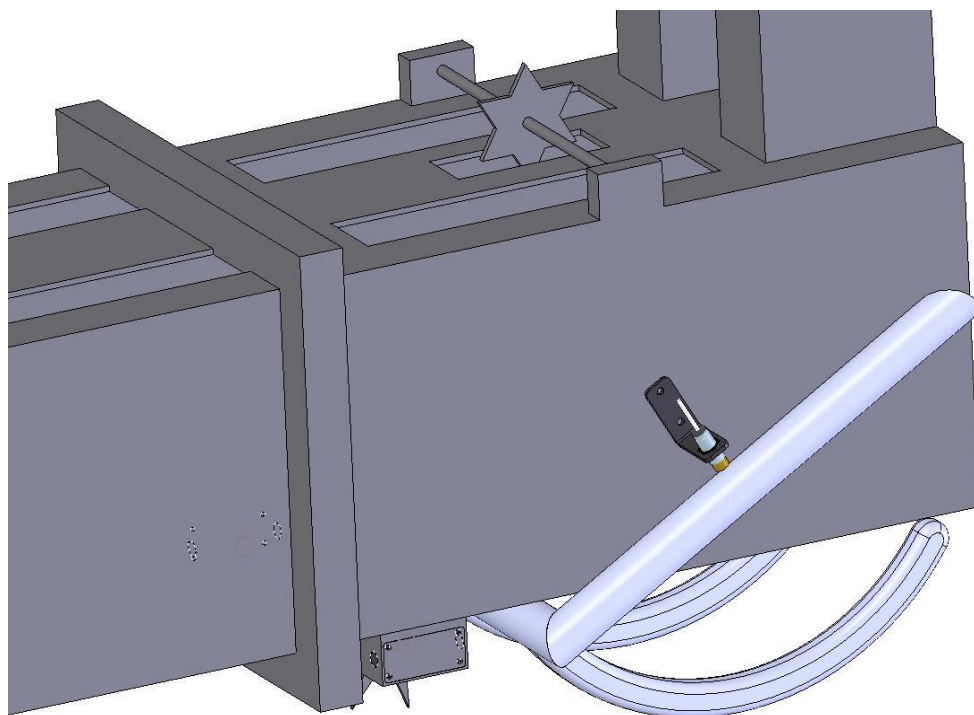
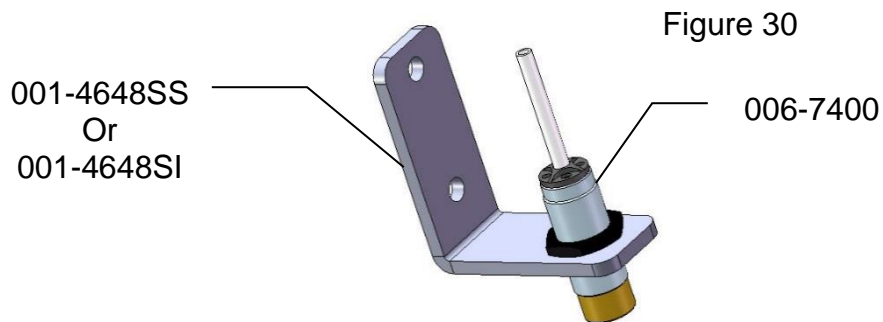

Installation of Stroke Counter Sensor

The stroke counter sensor determines how many plunger strokes were used to make a bale. This sensor works in combination with the end of bale sensor and sends the information to the DCP. The information will be saved in your Job Records and will also be displayed on the screen in Automatic or Manual mode. Follow the steps below for your baler to mount the sensor.

Model 651

Locate the steel behind the gathering fork (Figure 32). This shows the steel from the back of the baler, Figure 33 would be front and left. Mark and drill the 3/4" (19mm) hole for the sensor to mount through. With the tractor turned off and the PTO disconnected from the tractor, rotate the baler fly wheel by hand until the gathering fork arm is directly in front of the 3/4" (19mm) hole. Install the sensor and position so that the end of the sensor is 1/4" (7mm) away from the fork. Tighten the nuts on both sides of the sensor after the adjustment.

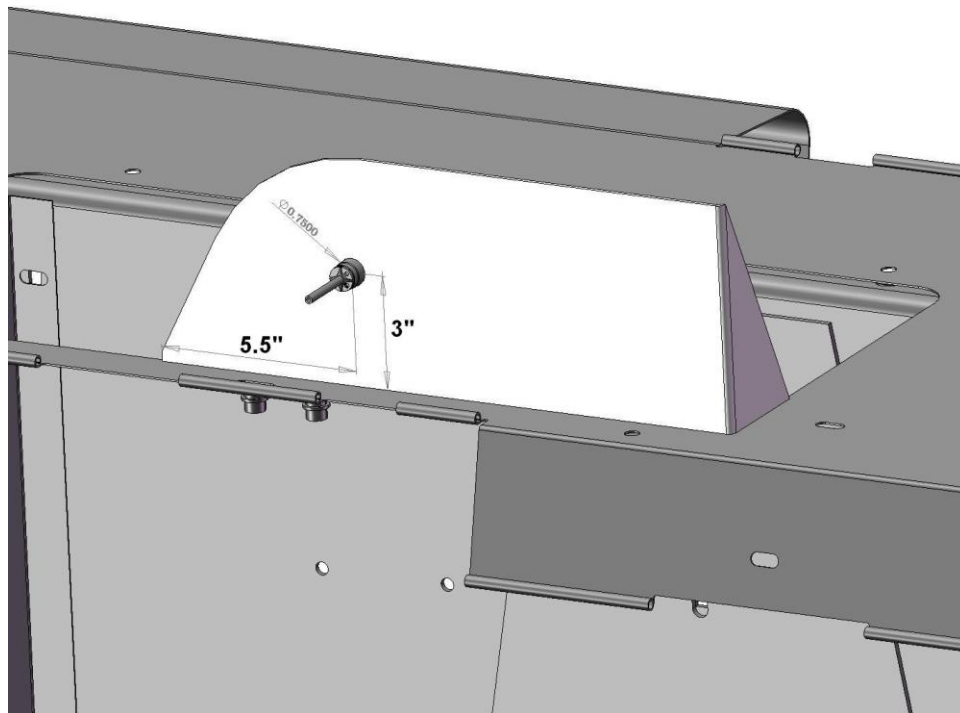

Figure 32

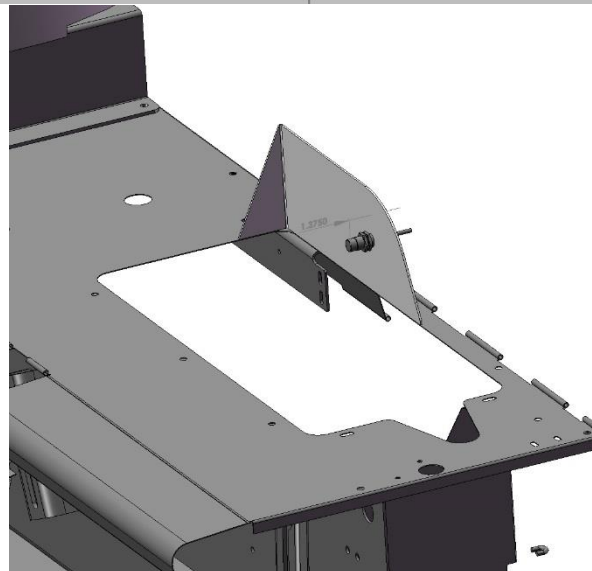

Figure 33

Model 644 & 650

Open the left access panel as shown in Figure 34. The end of the sensor (A) will be aligned with the bolt head (B). With the tractor turned off and the PTO disconnected from the tractor, rotate the balers flywheel so that the bolt head (B) is at its lowest position. Locate bracket 001-4648SC (B) and loosely install the sensor. Align the end of the sensor over the bolt head (B) and mark the two 3/8" (10mm) holes that will need to be drilled to mount the bracket (C). Install the bracket using two 5/16 x 1" bolts, flats, locks, and nuts. Close the access panel (Figure 35) and adjust the sensor so that it is 1/4" (7mm) away from the bolt head (B). Tighten the nuts on the sensor after the adjustment is made. Leave enough slack in the wire to allow the access door to function.

Figure 34

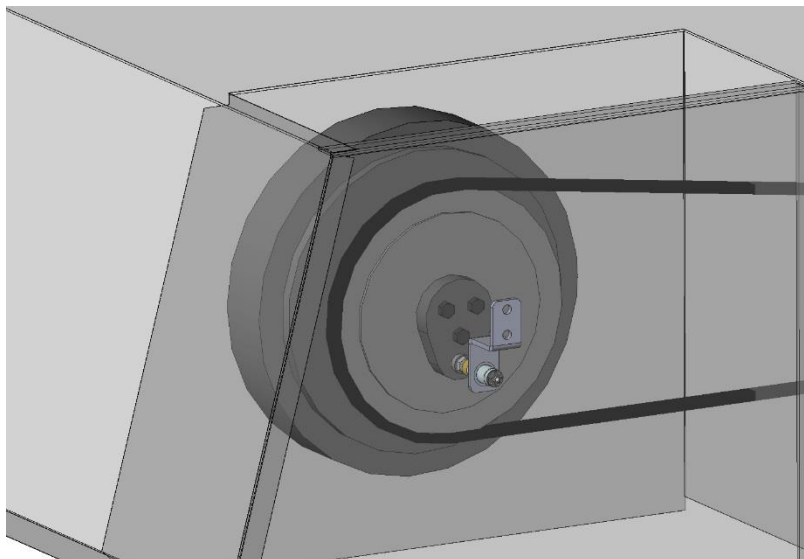
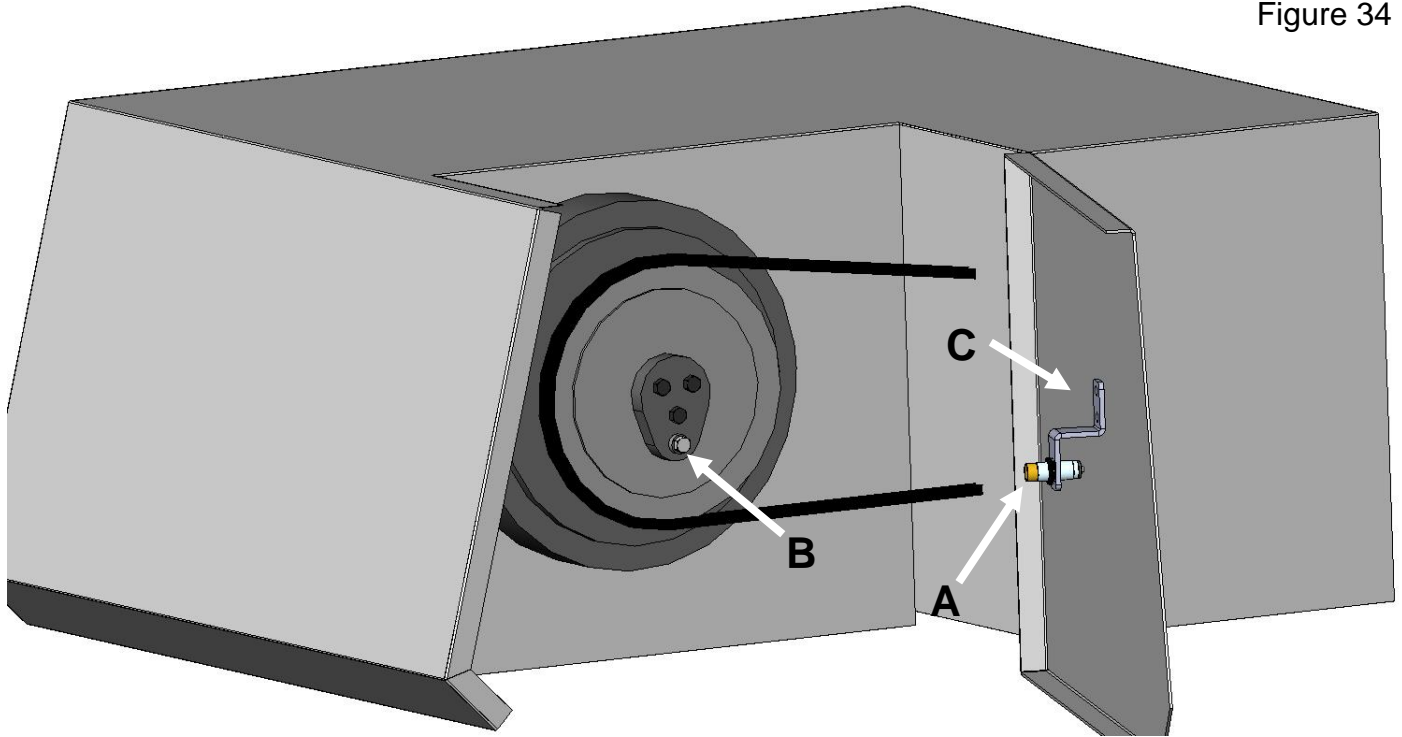

Figure 35

Model 645

Locate the area shown in Figure 36 on the baler. In Figure 1 the area is shown standing at the front of the baler and looking to the back. The bracket will mount on the steel next to the bearing on the gathering fork. Point (A) is the sheet metal on the back of the baler, point (B) is the steel that holds the gathering fork bearing, point (C) is the back arm on the gathering fork.

Locate the sensor bracket (001-4648RB). Mark and drill two 3/8" (10mm) holes to mount the bracket (D). Attach the bracket using two 5/16 x 1" bolts, flats, locks, and nuts. Loosely install the sensor into the bracket. With the tractor turned off and the PTO disconnected from the tractor, rotate the flywheel by hand to get the end of the sensor lined up with the gathering fork (C). The end of the sensor need to be 1/4" (7mm) away from gathering fork. After the adjustments are made tighten both nuts on the sensor.

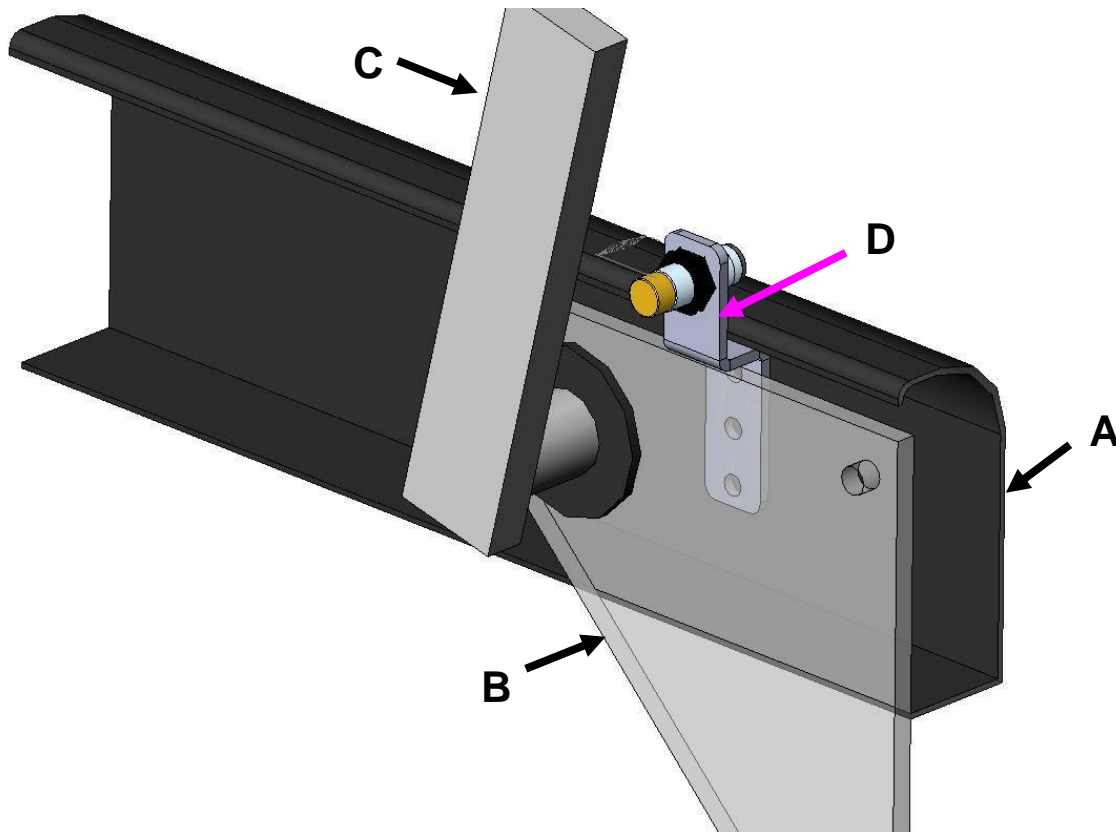

Figure 36

Installation of Star wheels & Bale Rate Sensor

Model 644, 645, 650 & 651(Two- Tie only)

The pair of star wheels will need to mount on the bottom side as close to the front of the bale chute as possible and at least 3/8" (10mm) away from any metal. They will need to maintain a safe distance away from the twine.

The star wheels will require two holes to be drilled per block, when drilling make sure to keep the wheel square to the bale chamber. Any angle will cause stress on the wheel and will eventually cause the wheel to work itself out of the block. Some balers may require a notch cut on the bottom of the bale chamber to mount the star wheels as close to the front of the chamber as possible. Use the template in back of manual to aid in installation.

Use the supplied bolts and place the carriage head inside of the bale chamber followed by lock and nut. Next attach the star wheels to the bolts followed by flat washer, lock washer and nut. The right side star wheel will have the bale rate sensor bolted to the bottom of the block.

First, remove the cover from the star wheel block and use a 1/4" (7mm) nut driver to remove the nut from the electronic swivel. Next, run the star wheel sensor wire through the black grommet and place the eye terminal on the star wheel sensor. Tighten the eye loop with the nut on the sensor and put the star wheel cover back on the base. Next, tighten the grommet to form a tight seal around the wire. The sensor with the longer sensor wire should say "FRONT", which indicates it should be placed in the front sensor hole. The sensor wire with the shorter wire should say "BACK." The tip of the sensor should be placed no more than 1/4" (7mm) away from the star wheel teeth and no less than 1/8" (3mm) from the star wheel teeth. Each sensor will have an LED light located on the sensor by the sensor holder. Once the unit is powered up spin the wheel and make sure that both led lights turn on and off. If they don't turn on and off, adjustments may need to be made. Once the star wheel connection is complete, run the harness along the baler frame to the Dual Channel Processor (DCP). (See wiring installation on the following page 24.)

Figure 37

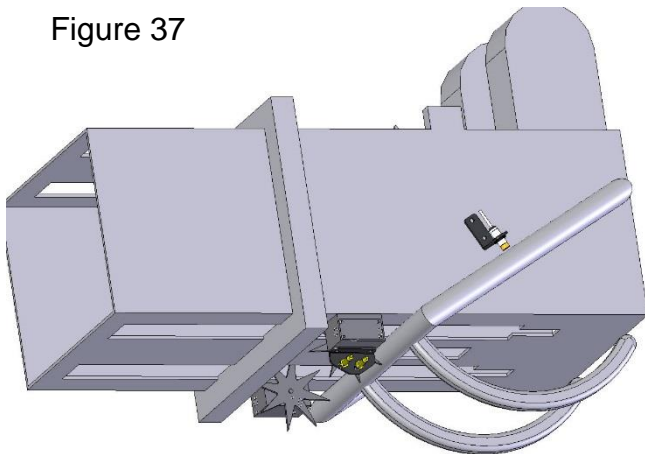

Model 651

Figure 38

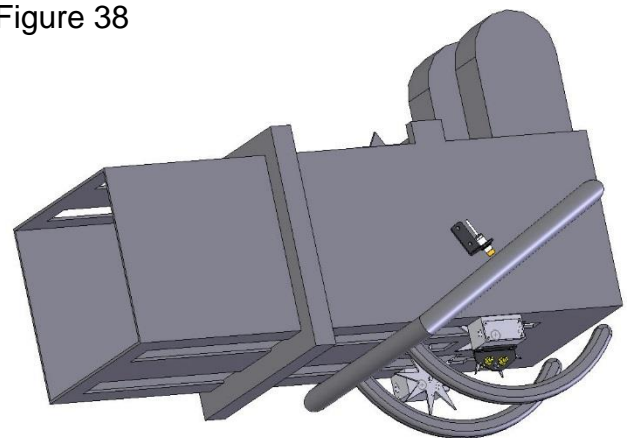

Model 644, 645 & 650

Model 650 (Three-Tie only)

The pair of star wheels will need to mount on the top as close to the knotters as possible and at least 3/8" away from any metal. They will need to maintain a safe distance away from the twine.

The star wheels will require two holes to be drilled per block, when drilling make sure to keep the wheel square to the bale chamber. Any angle will cause stress on the wheel and will eventually cause the wheel to work itself out of the block. A template can be found in the back of the manual to help with the placement of the star wheel.

Use the supplied 5/16" allen head carriage bolts and place the carriage head inside of the bale chamber followed by lock and nut. Next attach the star wheels to the bolts followed by the twine diverters 001-4644 and 001-4645. Finally secure the entire block using nuts, locks, and flat washers. The twine diverter with the bale rate sensors needs to be mounted on the right side of the baler.

Remove the four screws holding the plastic cover and attach one wire eye loop per star wheel through the grommet and tighten down with the nut attached to the swivel. Reinstall the cover and run the wires up to the pump plate. You will need to use zip ties to attach the wires so as to not interfere with normal baler use.

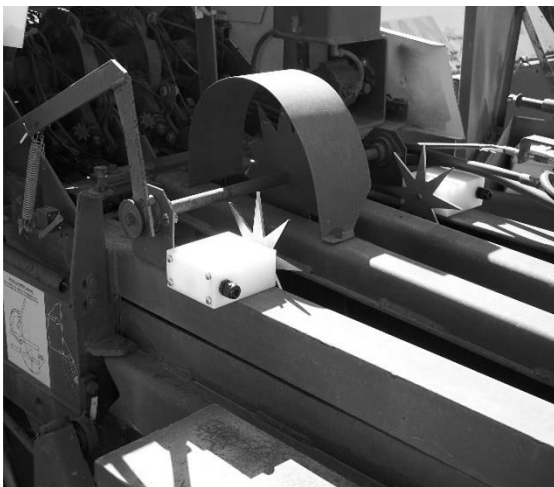

Freeman Balers



Hesston & New Holland Balers

9. Installation of Controls

Use the four mounting screws to mount the round base in a convenient area in your cab or on your fender. If unit is mounted on fender it will need to be removed at night and stored in a clean, dry area. Use the Ram mount swivel-positioning nut to tighten the entire assembly. Adjust it so that you can view the entire screen and be able to use the touch screen without interfering with other tractor functions.

10. Installation of Display Cable Harness

On the bottom of the touch screen display you will find the main display wire plug. The harness (006-6650TM) will need to be attached to this plug and run through the cab towards the hitch where it will connect with its matching harness (006-6650SS) from the DCP.

11. Main Wiring Harness and Power Cord Installation

Route cord 006-6650LS2 from the hitch to the back of the twine box or saddle leg. Keep cords away from moving parts and hydraulic hoses. Secure with existing cable clamps or use cable ties. .

Wiring Diagram

1. Connect the tractor Power / Communication (006-6650TM(E)) to the battery. The red power wire with the 50 amp fuse to the positive side (12 volt) of the battery. Connect the black ground wire to frame of tractor or negative side.
 - a. The power harness must be connected to the battery! The unit will draw more amps than convenience outlets can handle. Any modifications of the power harness will void systems warranty. IF MODIFICATIONS ARE REQUIRED CONTACT HARVEST TEC FIRST!
 - b. This unit will not function on positive ground tractors.
2. Connect Pump Controller Harness (006-5650FC* or 006-5650F2M *) to DCP & Pump Control (006-5672)
 - a. Connect Pump Harness (006-4660Z) and Flow Meter (006-4725A) to pump controller
3. Connect Moisture / Bale Rate Harness (006-7303H) to DCP.
4. Connect iPad Integration Control (030-6672C) to the Communication Harness (006-6650TM(E)).
5. Connect the orange wires and attach the plug to the tractor's ISOBUS port.

**Pump Control Harnesses 650 & 645 Models – 006-5650FC | 651 Model – 006-5650F2M*

SYSTEM WIRING DIAGRAM

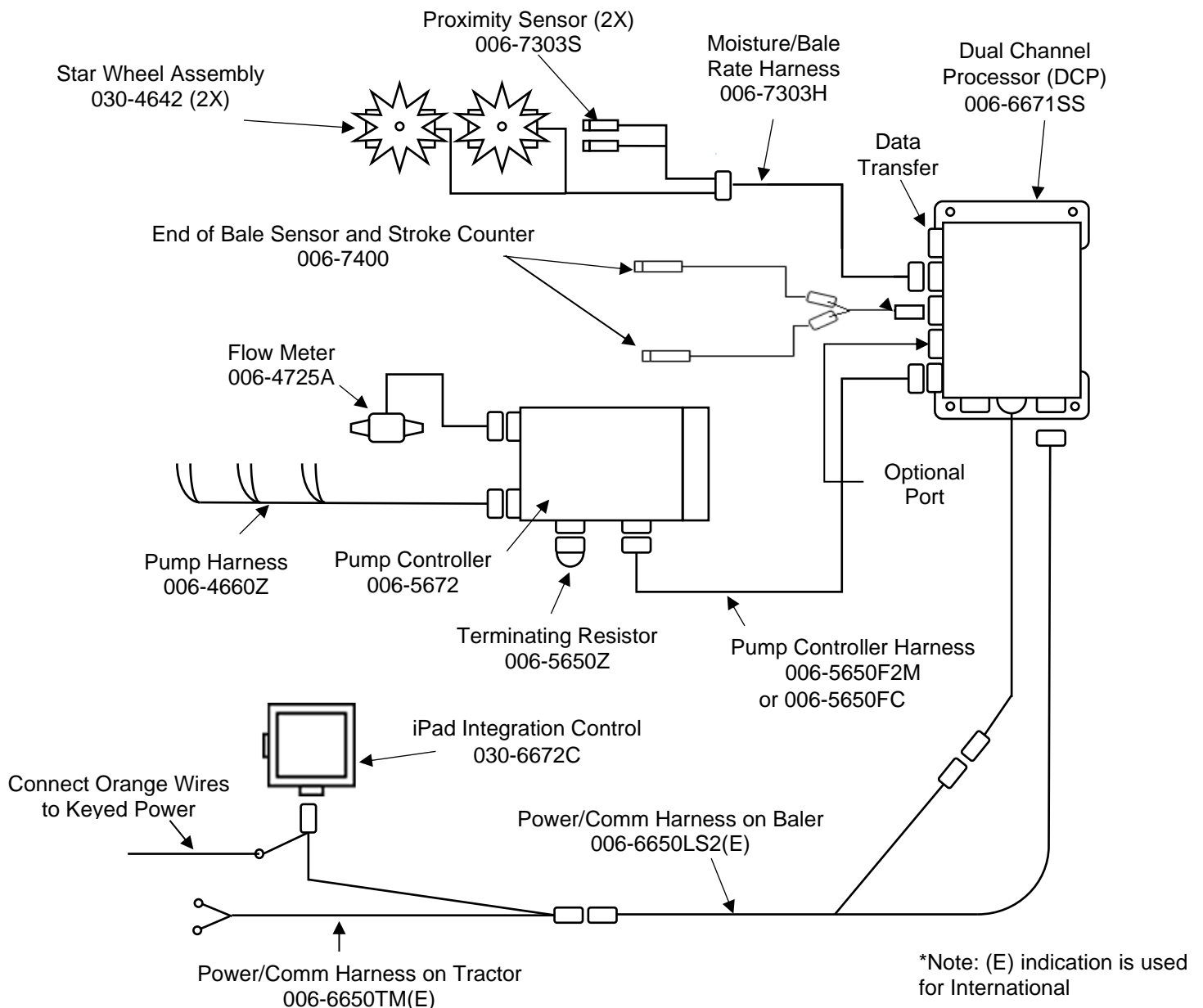

Pin Outs

A. Communication and power harness

Pin 1	Red	Can 12 volt
Pin 2	Red	Battery 12 volt
Pin 3	Orange	Keyed power
Pin 4	Not Used	
Pin 5	Yellow	Comm channel OL
Pin 6	Green	Comm channel OH
Pin 7	Not used	
Pin 8	Black	Can ground
Pin 9	Black	Battery ground
Pin 10	Not used	

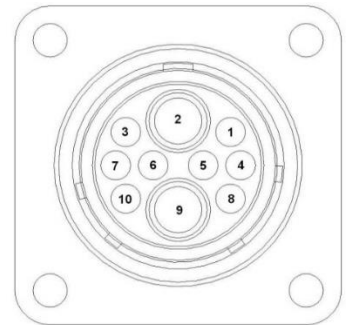

B. Main power connector mounted on DCP

Pin 1	Red	+ 12 V input from tractor supply
Pin 2	Black	Ground from tractor supply
Pin 3	Orange	Keyed power

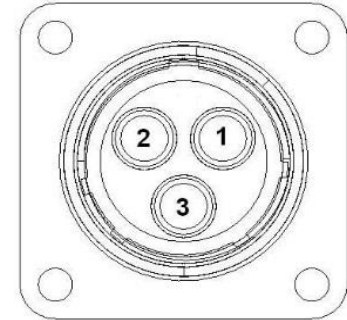

C. Pump connection colors

Pin 1	Black with orange markings	Pump 1 ground
Pin 2	Black with green markings	Pump 2 ground
Pin 3	Black with yellow markings	Pump 3 ground
Pin 4	Not used	
Pin 5	Orange with black markings	Pump 1 positive
Pin 6	Green with black markings	Pump 2 positive
Pin 7	Yellow with black markings	Pump 3 positive

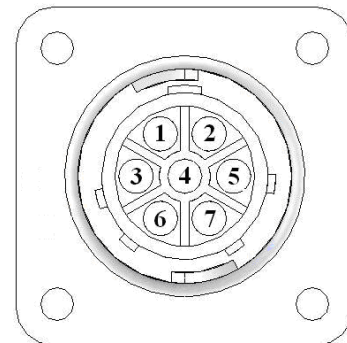

D. Flow meter connection on Pump Controller

Pin 1	White	5 - 12 V (+) supply
Pin 2	Green	Ground
Pin 3	Brown	Signal
Pin 4	Black	Shield

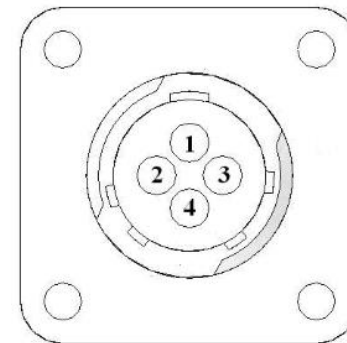

E. Connector for Hay Indicator option on DCP

Note: Hay indicators are an option that will turn the system on and off automatically as hay enters the pickup of the baler.

Pin 1	Red	+12V
Pin 2	Black	Ground
Pin 3	White	Signal wire
Pin 4	Not used	

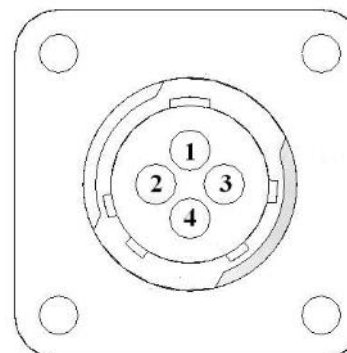

Pin Outs (continued)

F. End of bale sensor on DCP

Pin1	Brown	<u>Sensor power</u>
Pin2	Blue	Sensor ground
Pin3	Not used	
Pin4	Black	Signal from sensor

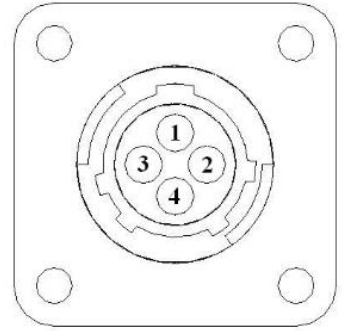

G. Moisture and Bale rate sensor connector on DCP

Pin 1	Not used	
Pin 2	Not used	
Pin 3	Not used	
Pin 4	Not used	
Pin 5	Silver	Shield
Pin 6	Silver	Shield
Pin 7	Not used	
Pin 8	Violet	Moisture input 1
Pin 9	Brown	Moisture input 2

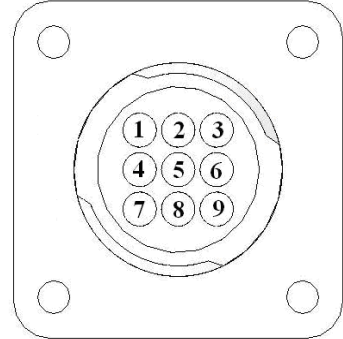

H. Communication harness on DCP

Pin 1	Orange	Power to display
Pin 2	Blue	Ground to display
Pin 3	Green	Comm channel OH
Pin 4	Not used	
Pin 5	Yellow	Comm channel OL
Pin 6	Not used	
Pin 7	Not used	

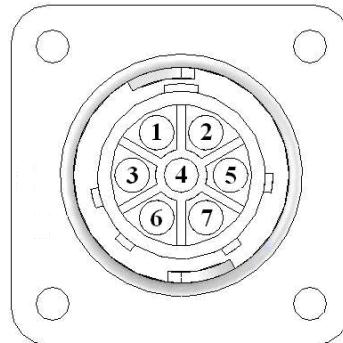

I. Communication harness on DCP and Pump Controller

Pin 1	Red	Can 12 volt
Pin 2	Red	Battery 12 volt
Pin 3	Grey	Shield
Pin 4	Green	Comm channel OH
Pin 5	Yellow	Comm channel OL
Pin 6	Blue	Comm channel IH
Pin 7	Orange	Comm channel IL
Pin 8	Black	Can ground
Pin 9	Black	Battery ground
Pin 10	Not used	

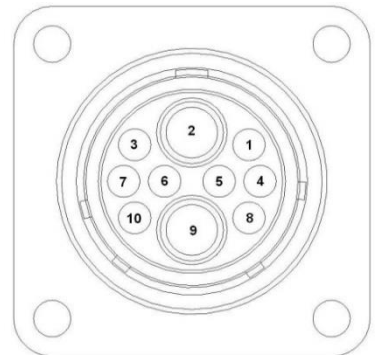

ISOBUS Plug Tractor Side

Pin 1	N/A
Pin 2	N/A
Pin 3	+12V Keyed Tractor Power
Pin 4	N/A
Pin 5	N/A
Pin 6	N/A
Pin 7	N/A
Pin 8	Orange Can1 Hi
Pin 9	Blue Can1 Low

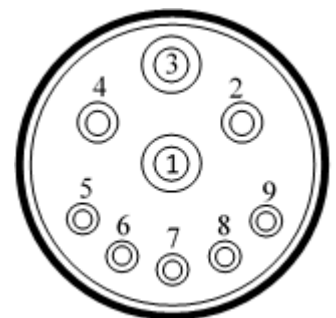

Parts Breakdown Model 644 Base Kit- Top Mount

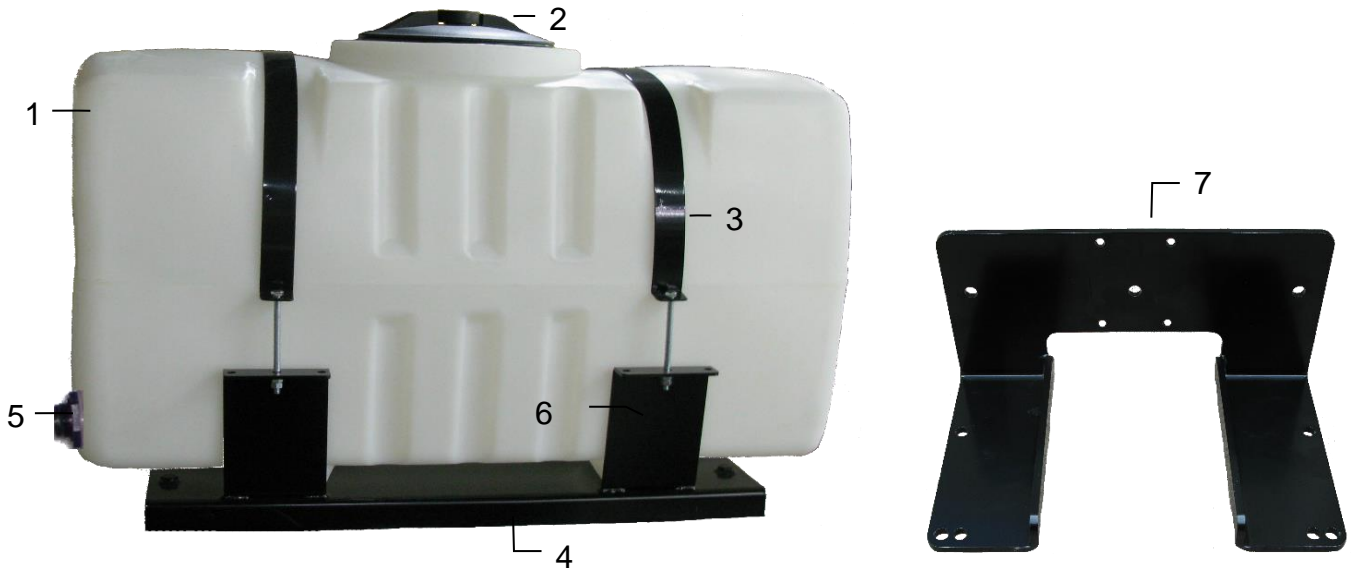

<u>Ref#</u>	<u>Description</u>	<u>Part #</u>	<u>Qty</u>	<u>Ref#</u>	<u>Description</u>	<u>Part #</u>	<u>Qty</u>
1	Tank	005-9203SQ	1	5	Tank fitting	005-9100	1
2	Tank lid	005-9022H	1	6	Strap Base	001-4703CC	4
3	Tank straps	001-4402	2	7	Pump Plate Mount	001-4647	1
4	Tank Saddle	001-4703X	1				
					Tank Saddle Kit (1-5)	030-0432-TK	
					4647 Mount Kit (6)	PMP-4647MT	

Model 6444417B Base Kit-Side Mount

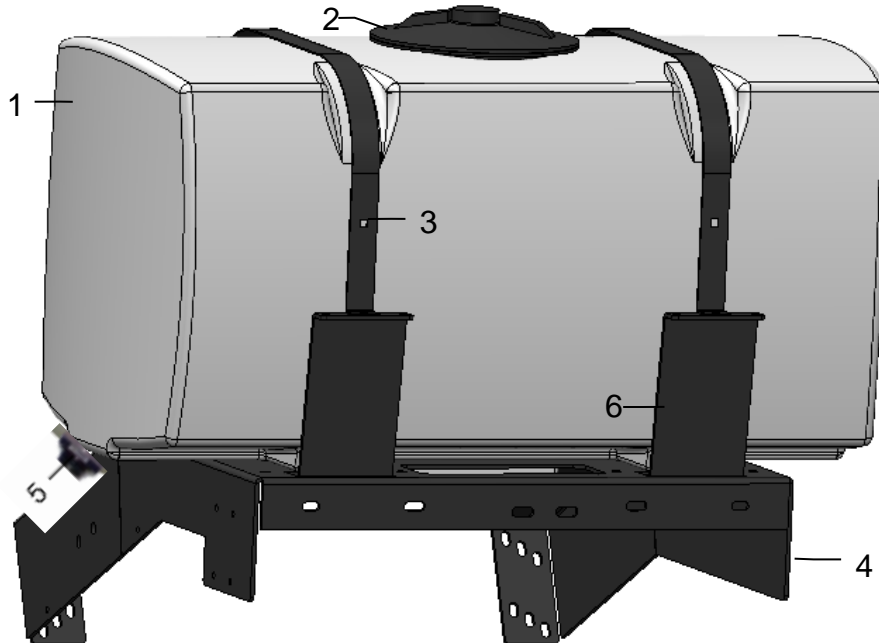

<u>Ref#</u>	<u>Description</u>	<u>Part #</u>	<u>Qty</u>	<u>Ref#</u>	<u>Description</u>	<u>Part #</u>	<u>Qty</u>
1	Tank	005-9203SQ	1	4	Tank Saddle	001-4703S	1
2	Tank lid	005-9022H	1	5	Tank fitting	005-9100	1
3	Tank straps	001-4402	2	6	Strap Base	001-4703CD	4
					Tank Saddle Kit (1-5)	030-0432-TK	
					4647 Mount Kit (6)	PMP-4647MT	

Model 645 Base Kit

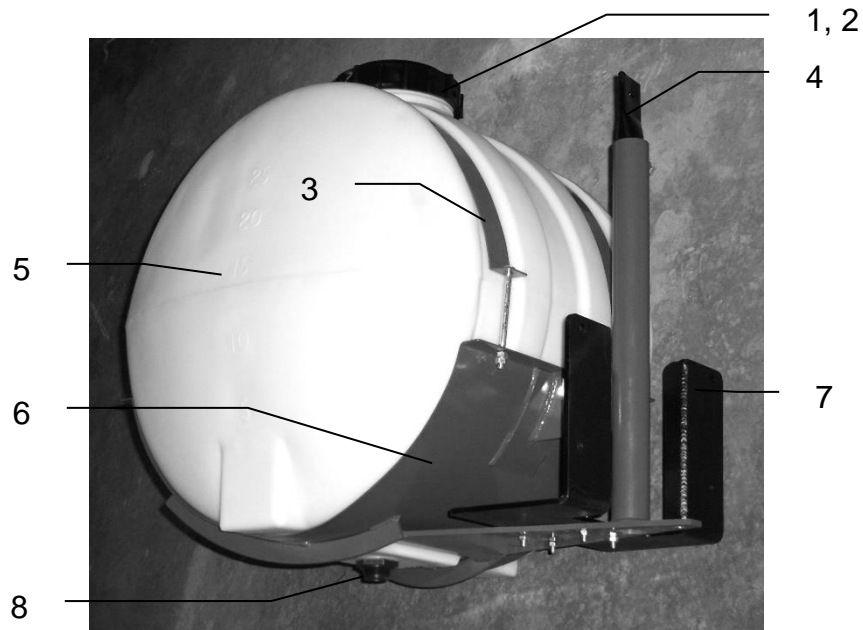

<u>Ref#</u>	<u>Description</u>	<u>Part #</u>	<u>Qty</u>	<u>Ref#</u>	<u>Description</u>	<u>Part #</u>	<u>Qty</u>
1	Tank Cap	005-9022C	1	5	Tank	005-9022	1
2	Tank Cap Gasket	005-9022CG	1	6	Saddle	001-4401	1
3	Tank Strap	001-4402	2	7	Mounting Bracket	001-4647	1
4	Stub Pipe	001-4403	1	8	Tank Fitting	005-9100	1

Model 650 Base Kit

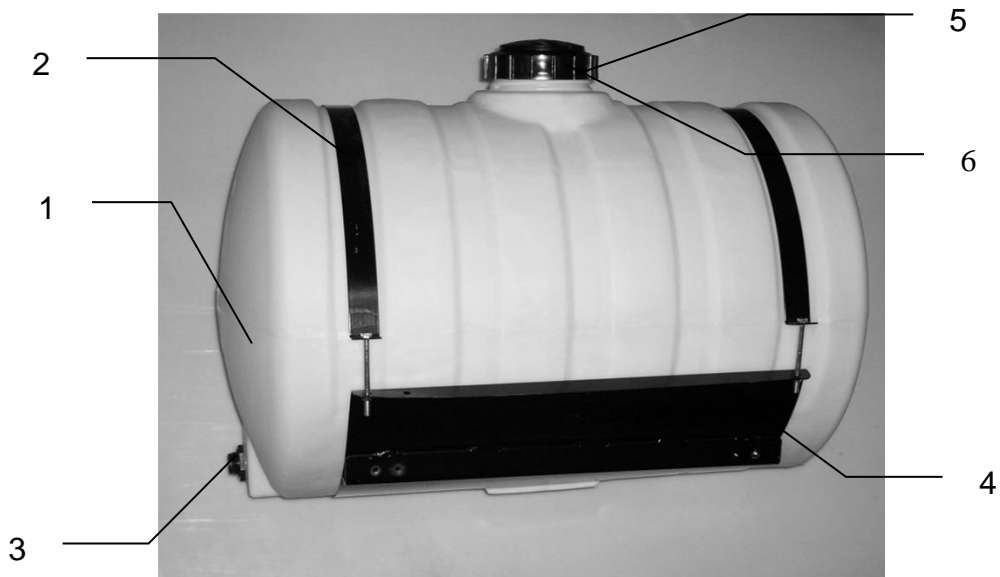

<u>Ref#</u>	<u>Description</u>	<u>Part #</u>	<u>Qty</u>	<u>Ref#</u>	<u>Description</u>	<u>Part #</u>	<u>Qty</u>
1	Tank	005-9203	1	4	Saddle	001-4703	1
2	Straps	001-4402	2	5	Tank Cap	002-9022C	1
3	Tank Fitting	005-9100	2	6	Tank Gasket	002-9022CG	1
				NP	DCP mount	001-4703BPM	2

Model 651 Base Kit

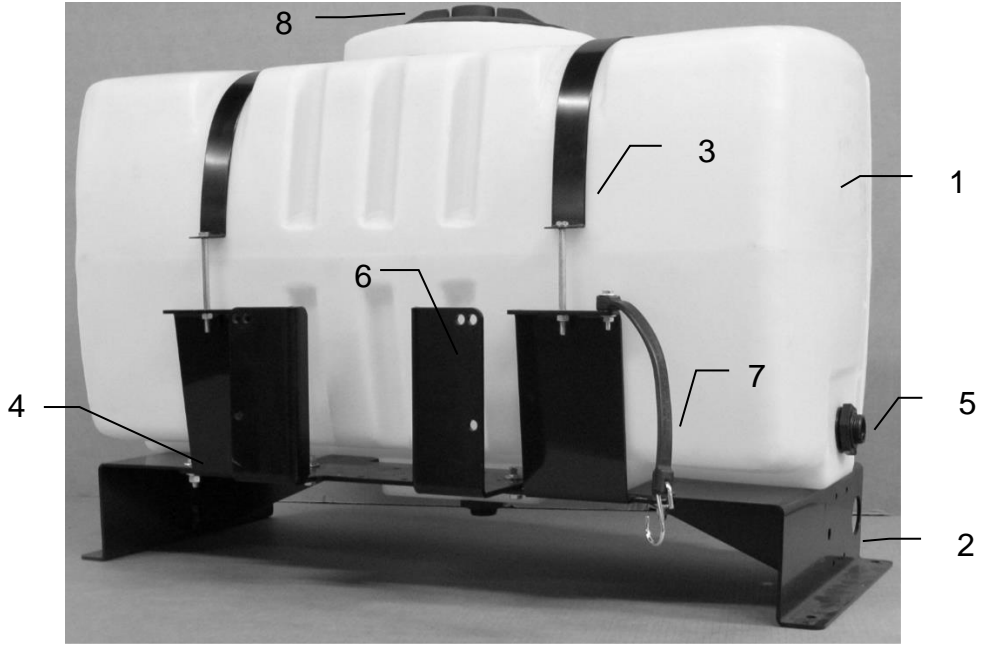

<u>Ref#</u>	<u>Description</u>	<u>Part #</u>	<u>Qty</u>	<u>Ref#</u>	<u>Description</u>	<u>Part #</u>	<u>Qty</u>
1	Tank	005-9203SQ	1	6	Mounting Bracket	001-4647	1
2	Tank Saddle	001-4703C	1	7	Door Latch	001-4703CL	1
3	Tank Straps	001-4402	2	8	Tank Lid	005-9022H	1
4	Short Strap Base	001-4703CC	2	NP	Long Strap Base	001-4703CD	2
5	Tank fitting	005-9100	2	NP	Not Pictured		

Parts Breakdown for Pump Manifold

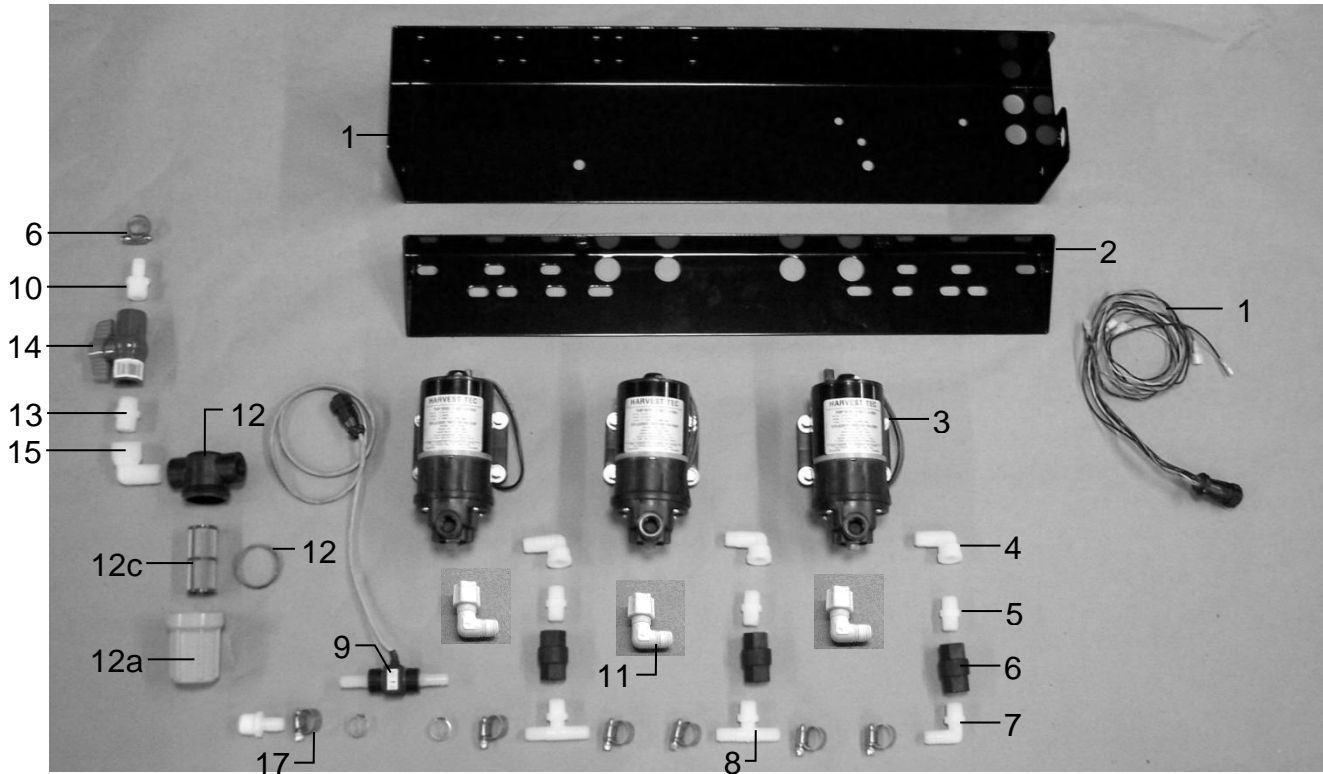

<u>Ref#</u>	<u>Description</u>	<u>Part#</u>	<u>Qty</u>
1	Pump plate	001-4646D	1
2	Mounting Bracket	001-4646C	1
3	Pump	007-4120H	3
4	Street elbow fitting	003-SE38	3
5	Nipple fitting	003-M3838	3
6	Check valve	002-4566F	3
7	Elbow fitting	003-EL3812	1
8	Tee fitting	003-T3812HB	2
9	Flow meter assembly	006-4725A	1
10	Straight fitting	003-A1212	2
11	Jaco fitting	003-JEL1238	3
12	Filter bowl assembly	002-4315-100	1
12a	Filter bowl only	002-4315F	1
12b	Filter bowl gasket	002-4315D	1
12c	Filter bowl screen	002-4315A	1
13	Nipple fitting	003-M1212	1
14	Ball valve	002-2212	1
15	Street elbow fitting	003-SE12	1
16	Hose clamp	003-9003	7
17	Hose clamp (Flow Meter)	003-9005	2
18	Pump Cable	006-4660Z	1
NP	Elbow	003-EL1212	1
NP	Pump rebuild kit (1 per pump)	007-4581	1
	Complete Pump Assembly	030-4646	

Parts Breakdown for Star Wheels, Bale Rate Sensor, and Hoses

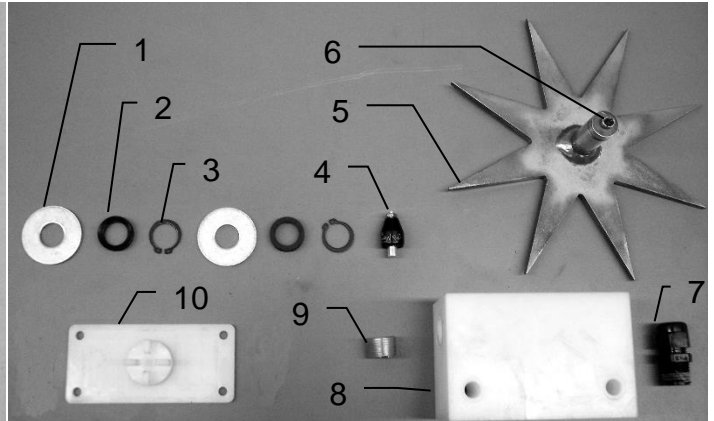
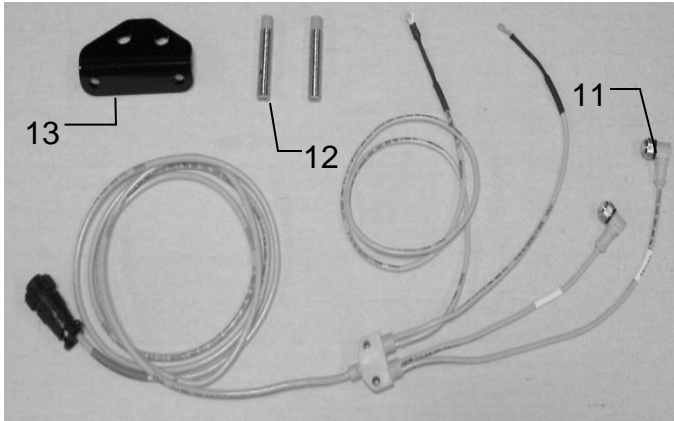

Ref	Description	Part#	Qty
1	Washer (per side)	006-4642K	2
2	Dust Seal (per side)	w/006-4642K	1
3	Snap Ring (per side)	w/006-4642K	2
4	Swivel	006-4642A	2
5	Star Wheel	030-4641E	2
6	Insert	w/ Ref # 5	2
7	Wiring grommet	008-0821A	2
8	Star wheel block	006-4641D	2
9	Plug Fitting	003-F38	2
10	Block Cover	006-4641B	2
1-10	Star wheel assembly	030-4642	2

Ref	Description	Part#	Qty
11	Bale rate & moisture cable	006-7303HS	1
12	Bale rate sensor	006-7303S	2
13	Bale rate sensor holder	001-4644SS	1

Drain / Fill Kit

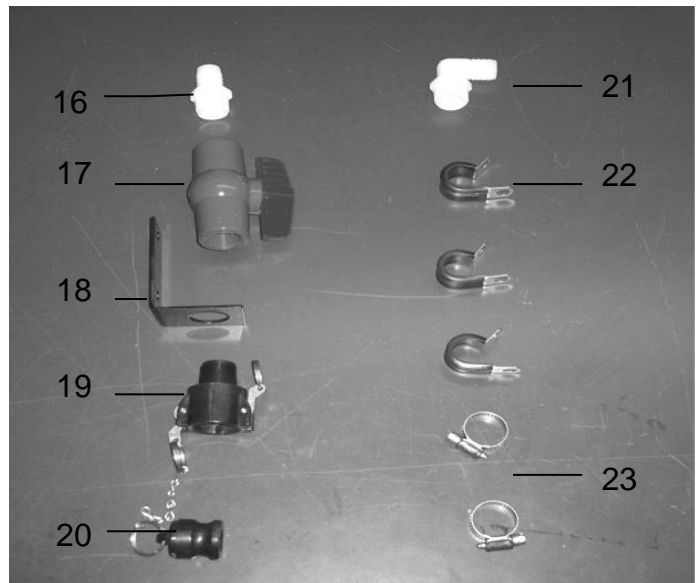

Hose Assembly

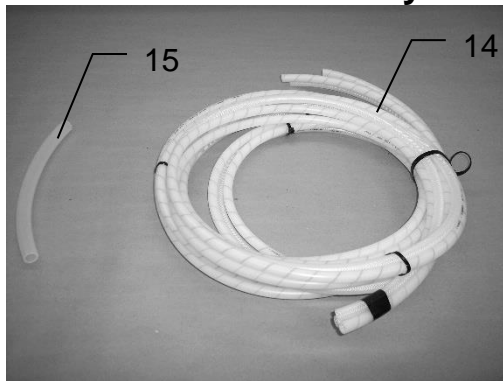

Ref	Description	Part#	Qty
14	Triple weld hose (pumps to tips)	002-9016	15ft
		002-9016B	15ft
		002-9016G	15ft
	Hose assembly (3 hose assembly)	030-9016SS	1
15	½" Hose (tank to filter)	002-9001	6ft

Ref #	Description	Part #	Qty
16	Straight Fitting	003-A3434	1
17	Ball valve	002-2200	1
18	Valve Holder	001-6702H	1
19	Female Coupler	002-2204A	1
20	Male Coupler	002-2205G	1
21	Elbow	003-EL3434	1
22	Jiffy Clip	008-9010	3
23	Hose Clamps	003-9004	2
NP	¾" Hose	002-9002	8ft

Control Boxes and Wiring Harnesses

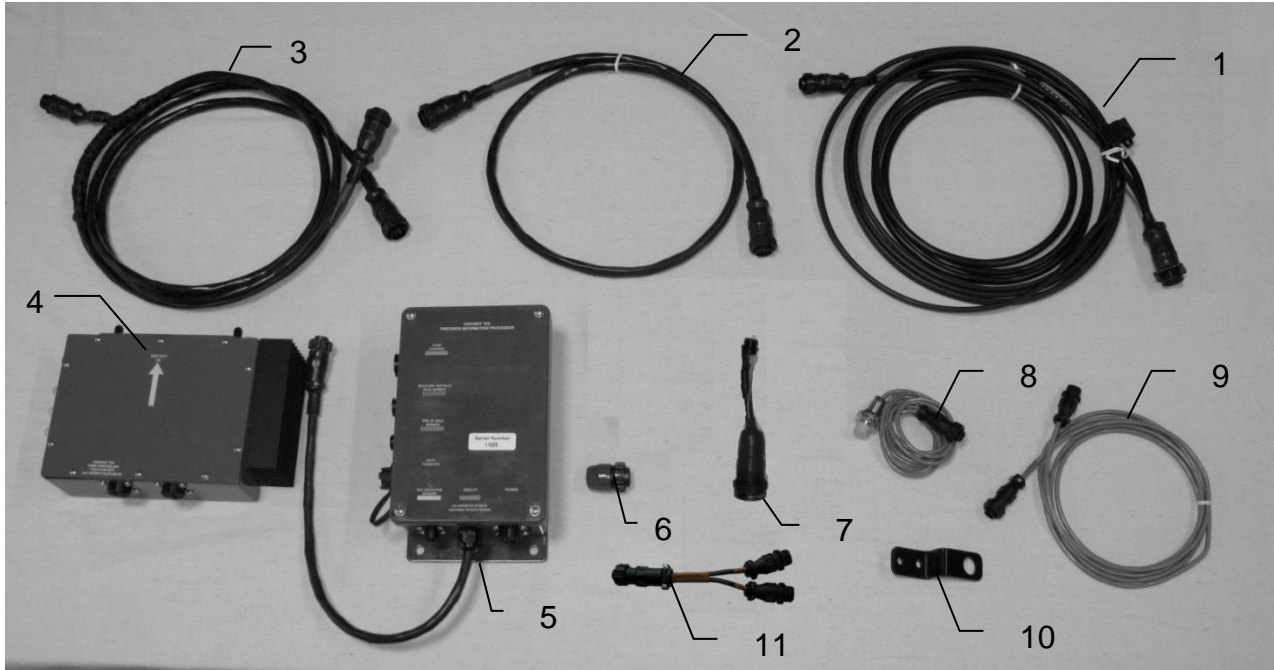

<u>Ref</u>	<u>Description</u>	<u>Part#</u>	<u>Qty</u>
1	Power & communication tractor	006-6650TM(E)	1
2	Pump controller harness (650 & 645)	006-5650FC	1
	Pump controller harness (651)	006-5650F2M	1
3	Power & communication baler	006-6650LS2(E)	1
4	Pump controller	006-5672	1
5	Dual Channel Processor (DCP)	006-6671SS	1
6	Terminating resistor	006-5650Z	1
7	Optional ISOBUS Tractor Plug (not included)	006-6670A	1
8	Bale rate timer	006-7400	2
9	Bale rate timer sensor extension	006-7400EXT	1
10	End of bale bracket (645 & 650)	001-4648SS	1
11	Y Splitter for Prox Sensors	006-7400Y	1
12	iPad Integration Control	030-6672C	1
NP	End of bale bracket (651)	001-4648SC	1
NP	Stroke counter bracket (645 & 650)	001-4648RB	1
NP	Stroke counter bracket (651)	001-4648SI	1
NP	Key switch wire	006-5650K	1
NP	Dust plug kit	006-5651PLUGS	1
NP	USB Cable	006-6672USBC	1



*Note: (E) indication is used for International

Model 4410B Installation Kit

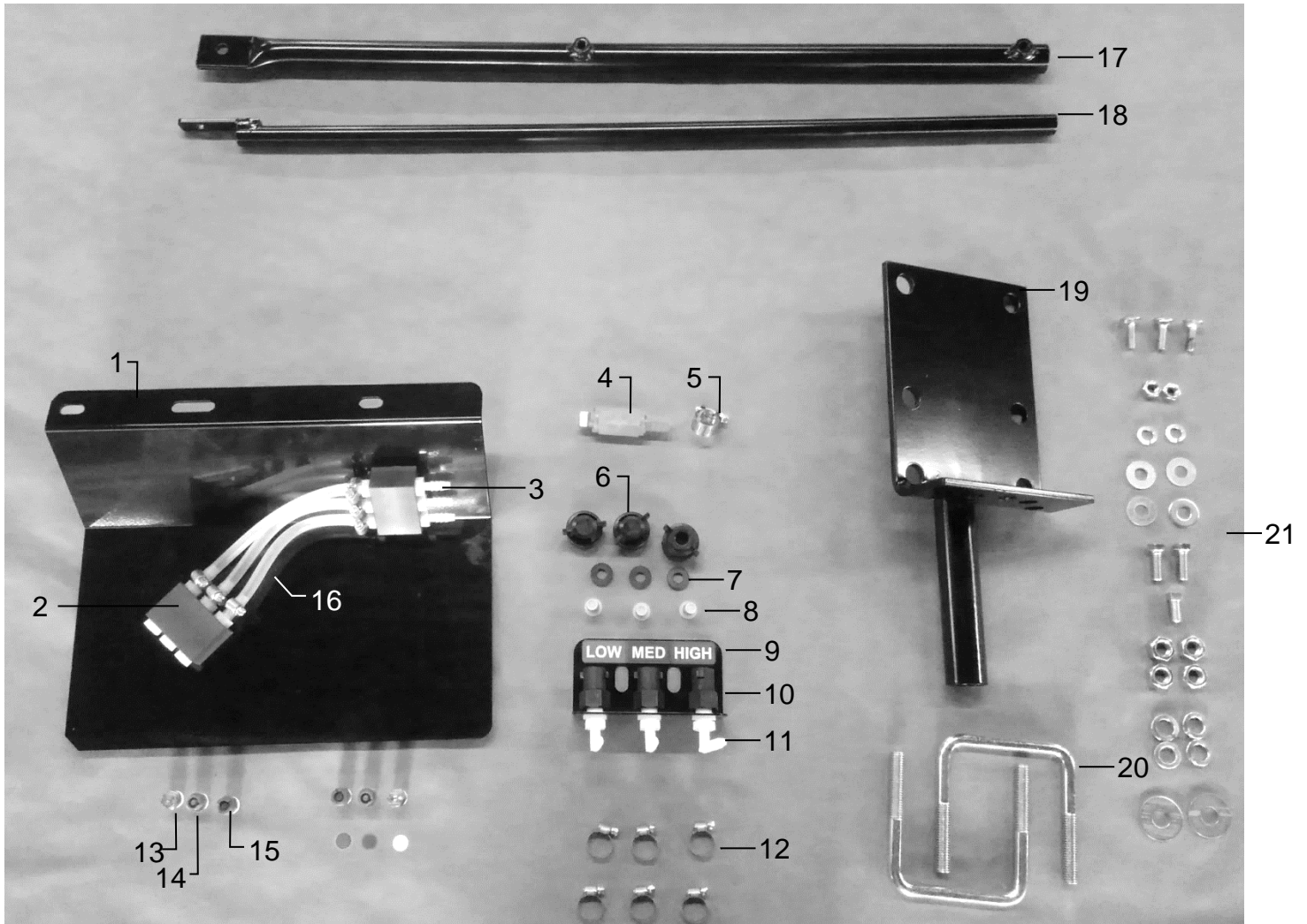

<u>Ref</u>	<u>Description</u>	<u>Part#</u>	<u>Qty</u>	<u>Description</u>	<u>Part#</u>	<u>Qty</u>	
1	Spray shield	001-4426A	1	12	Hose clamp	003-9002	12
2	Manifold Block	003-4435NSB	2	13	Tip - Silver	004-T650033-SS	2
3	Straight fitting	003-A1414	9	14	Tip - Silver	004-T650067-SS	2
4	Check valve	002-4564X	3	15	Tip - Silver	004-T65015-SS	2
5	Hose clamp	003-9003	1	16	Hose - Clear	002-9016	3 ft
6	Female discount	004-1207H	3		Hose - Blue	002-9016B	3 ft
7	Washer	004-1207W	3		Hose - Green	002-9016G	3 ft
8	Tip strainer	004-1203-200	3	17	Outside support rod	001-4404	1
9	Hose manifold	001-4720	1	18	Inside support rod	001-4405	1
10	Female coupler	004-1207G	3	19	Mounting bracket	001-4406	1
11	Elbow	003-EL1414	3	20	U bolt	001-4406A	2
				21	Mounting Hardware	Gen Hardware	
					Shield Only	030-4410B-SO	
					(Ref 1-16)		

Harvest Tec Model 4415B-SO Installation Kit

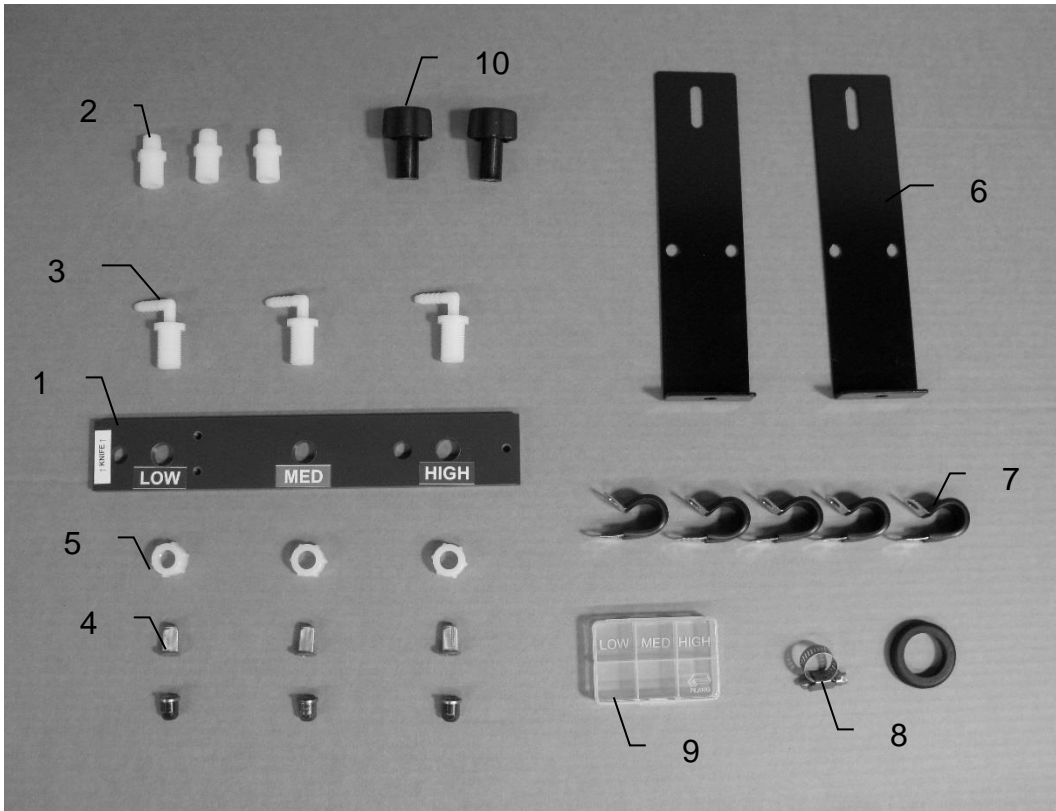

<u>Ref</u>	<u>Description</u>	<u>Part#</u>	<u>Qty</u>	<u>Description</u>	<u>Part#</u>	<u>Qty</u>
1	Spray shield	001-4425C	1	Tip (blue)	004-TX-SS-4	1
2	Drill guide	003-M3814NB	3	Tip (green)	004-TX-SS-10	1
3	Elbow	003-EL3814NB	3	Tip (brown)	004-TX-SS-18	1
4	Tip strainer	004-4213-100	3	* Tip color subject to change		
5	Nozzle cap	004-BC12	3			
6	Hose bracket	001-4425B	2			
7	Jiffy clip	008-9010	5			
8	Hose clamp	003-9003	3			
9	Tip box	008-9001	1			
10	Knob	008-0925	2			

Harvest Tec Model 4415B Installation Kit

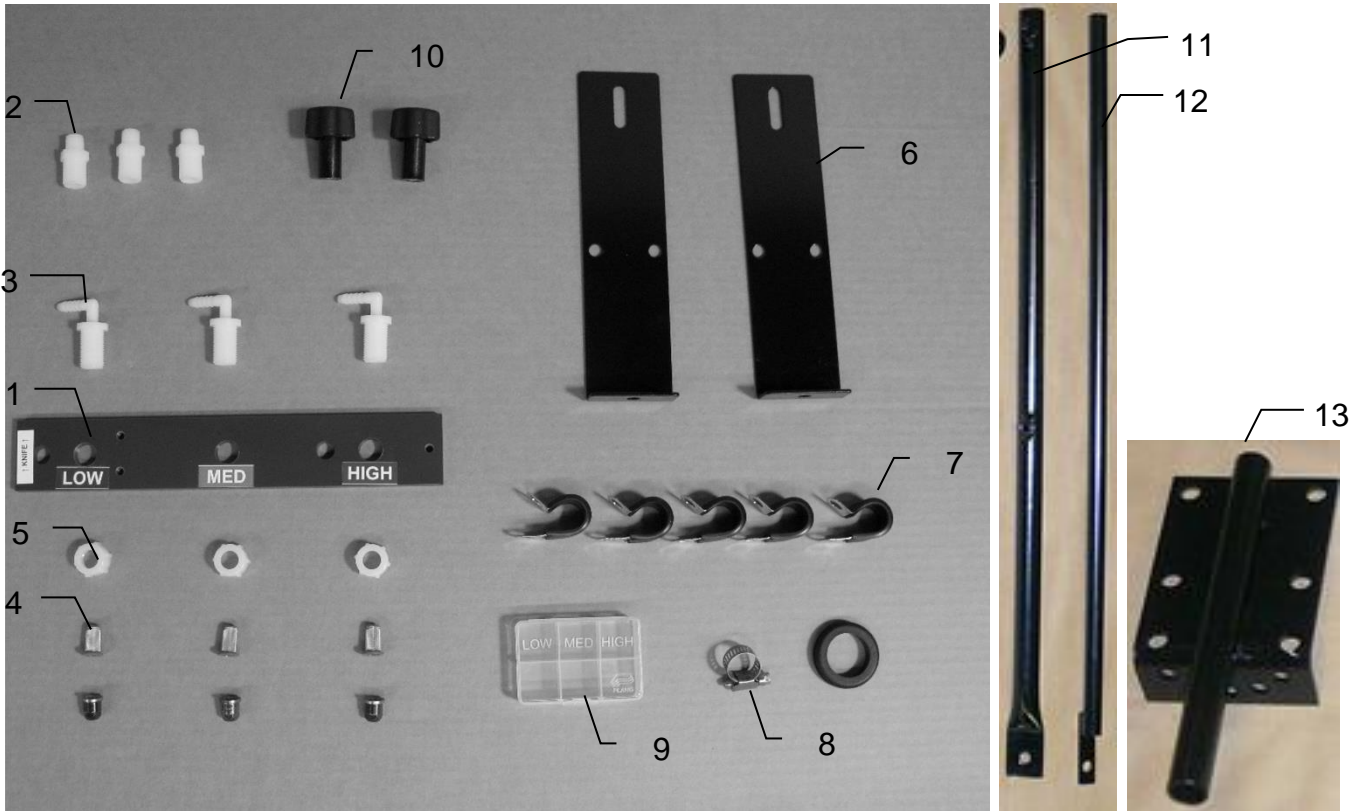

<u>Ref</u>	<u>Description</u>	<u>Part#</u>	<u>Qty</u>	<u>Ref</u>	<u>Description</u>	<u>Part#</u>	<u>Qty</u>
1	Spray shield	001-4425C	1	11	Inside reach rod	001-4405	1
2	Drill guide	003-M3814NB	3	12	Outside reach rod	001-4404	1
3	Elbow	003-EL3814NB	3	13	Mounting bracket	001-4406	1
4	Tip strainer	004-4213-100	3		Tip (blue)	004-TX-SS-4	1
5	Nozzle cap	004-BC12	3		Tip (green)	004-TX-SS-10	1
6	Hose bracket	001-4425B	2		Tip (brown)	004-TX-SS-18	1
7	Jiffy clip	008-9010	5				
8	Hose clamp	003-9003	3				
9	Tip box	008-9001	1				
10	Knob	008-0925	2				

* Tip color subject to change

Model 4416B Installation Kit

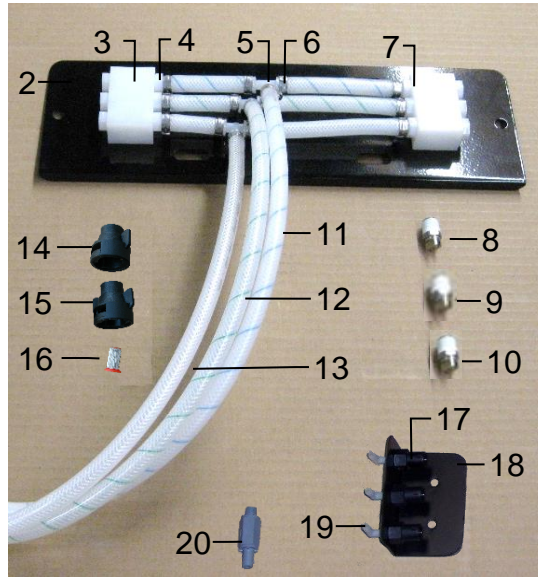
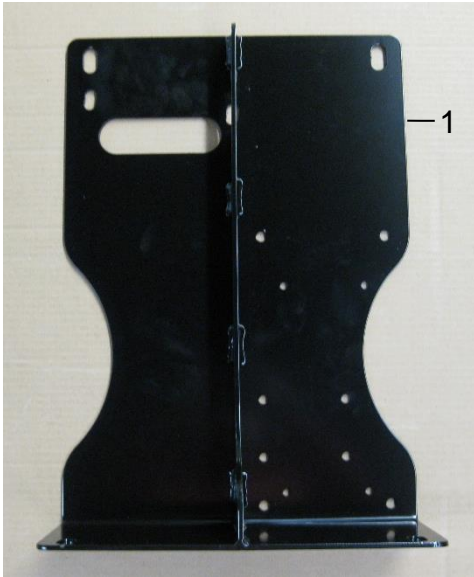

<u>Ref</u>	<u>Description</u>	<u>Part #</u>	<u>Qty</u>	<u>Ref</u>	<u>Description</u>	<u>Part#</u>	<u>Qty</u>
1	Saddle Legs	001-4703Q	2	14	1/4" Female Disconnect	004-1207H	3
2	Spray Shield	001-4424A2	1	15	Shut off cap	004-1207F	2
3	Plug	003-F14	6	16	Tip Strainer (200 mesh)	004-1203-200	3
4	Manifold Block	001-4435NSB	2	17	Female coupler	004-1207G	3
5	1/2" Otiker Clamp	003-9008	15	18	Hose bracket	001-4720	1
6	1/4" Tee	003-T1414	3	19	Elbow	003-EL1414	3
7	1/4" Straight fitting	003-A1414	6	20	Check valve	002-4564XB	3
8	Stainless Tip (small)	004-T650067-SS	2	21	Kicker Bracket	001-4703QC	1
9	Stainless Tip (med)	004-T65015-SS	2	NP	Spray Shield Holders	001-4424B	2
10	Stainless Tip (large)	004-T650033-SS	2	NP	Mini Hose Clamp	003-9002	6
11	1/4" Hose (green)	002-9016G	4				
12	1/4" Hose (blue)	002-9016B	4				
13	1/4" Hose (clear)	002-9016	4				
					4416B – SO Kit	030-4416B-SO	
					(Includes Ref 2-13 & Spray Shield Holders)		
					* Tip color subject to change		

Model 4417B Installation Kit

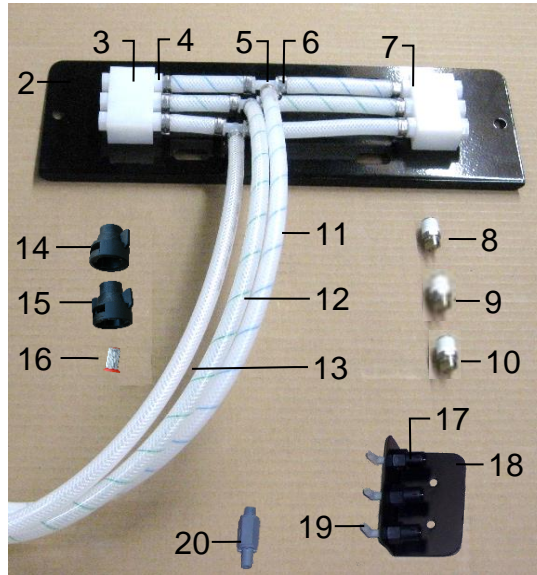

<u>Ref</u>	<u>Description</u>	<u>Part #</u>	<u>Qty</u>	<u>Ref</u>	<u>Description</u>	<u>Part#</u>	<u>Qty</u>
1	Support Bracket	001-4703QU	1	14	1/4" Female Disconnect	004-1207H	3
2	Spray Shield	001-4424A2	1	15	Shut off cap	004-1207F	2
3	Plug	003-F14	6	16	Tip Strainer (200 mesh)	004-1203-200	3
4	Manifold Block	001-4435NSB	2	17	Female coupler	004-1207G	3
5	1/2" Otker Clamp	003-9008	15	18	Hose bracket	001-4720	1
6	1/4" Tee	003-T1414	3	19	Elbow	003-EL1414	3
7	1/4" Straight fitting	003-A1414	6	20	Check valve	002-4564XB	3
8	Stainless Tip (small)	004-T650067-SS	2	21	U-Bolt	001-4703QUX	1
9	Stainless Tip (med)	004-T65015-SS	2	22	U-Bolt	001-4703QUB	2
10	Stainless Tip (large)	004-T650033-SS	2	NP	Spray Shield Holders	001-4424B	2
11	1/4" Hose (green)	002-9016G	4	NP	Mini Hose Clamp	003-9002	6
12	1/4" Hose (blue)	002-9016B	4		4416B – SO Kit	030-4416B-SO	
13	1/4" Hose (clear)	002-9016	4		(Includes Ref 2-13 & Spray Shield Holders)		

* Tip color subject to change



Model 4485B Installation Kit

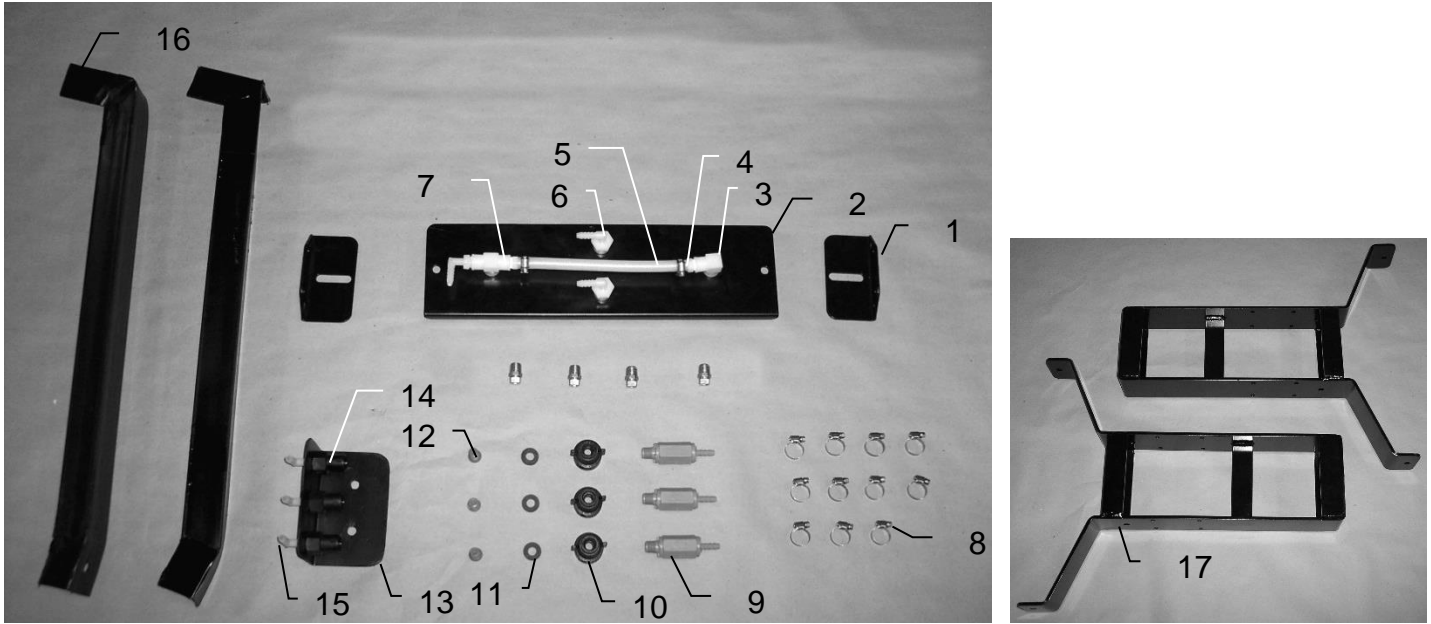

<u>Ref</u>	<u>Description</u>	<u>Part#</u>	<u>Qty</u>	<u>Ref</u>	<u>Description</u>	<u>Part#</u>	<u>Qty</u>
1	Shield holder	001-4424B	2		Tip (silver)	004-T650033-SS	2
2	Spray shield	001-4424A	1		Tip (silver)	004-T110015-SS	1
3	Elbow	003-SE14F	1		Tip (silver)	004-T11003-SS	1
4	Straight fitting	003-A1414	2				
5	Hose	002-9016	9 ft				
6	Elbow	003-EL1414F	2				
7	Tee	003-TT14SQ	1				
8	Hose clamp	003-9002	11				
9	Check valve	002-4564XB	3				
10	Female disconnect	004-1207H	3				
11	Washer	004-1207W	3				
12	Tip strainer	004-1203-200	3				
13	Hose bracket	001-4720	1				
14	Female coupler	004-1207G	3				
15	Elbow	003-EL1414	4				
16	Leg support	001-4424C	2				
17	Saddle leg	001-4703B	2				

* Tip color subject to change

Model 4502B Installation Kit

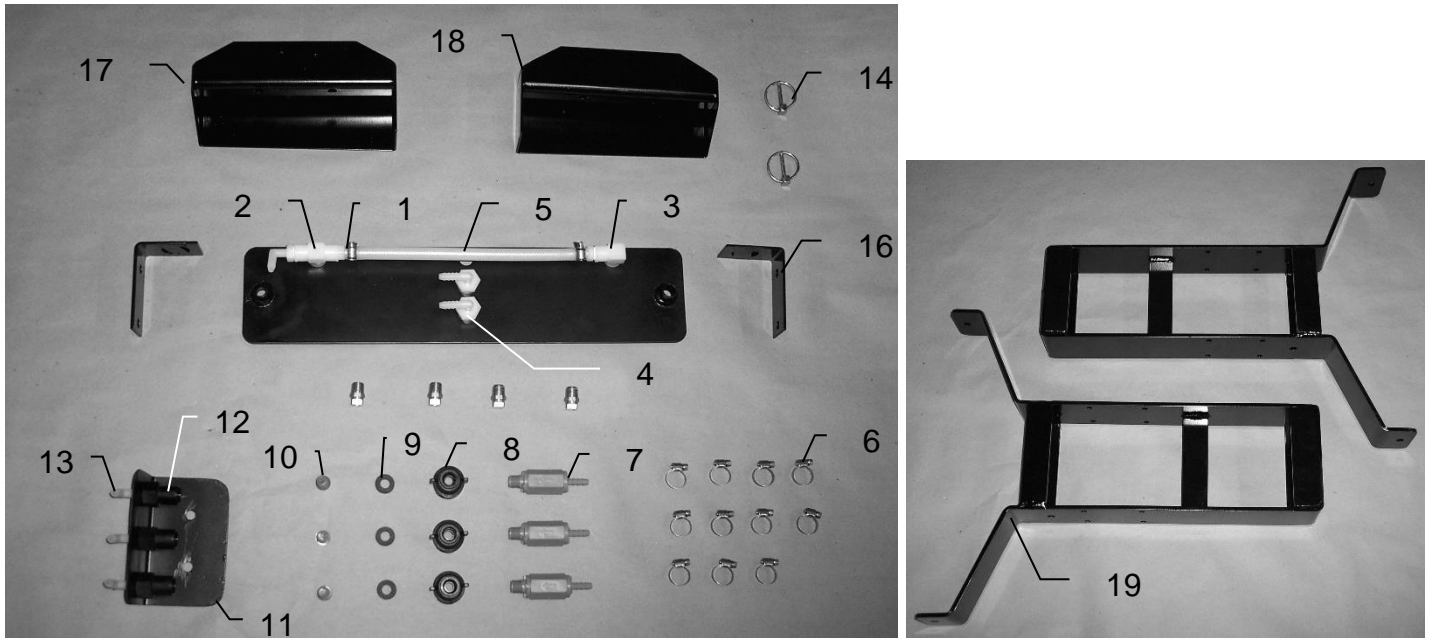

<u>Ref</u>	<u>Description</u>	<u>Part #</u>	<u>Qty</u>	<u>Description</u>	<u>Part#</u>	<u>Qty</u>
1	Straight fitting	003-A1414	2	Tip (silver)	004-T650050-SS	2
2	Tee	003-TT14SQ	1	Tip (silver)	004-T110015-SS	1
3	Elbow	003-SE14F	1	Tip (silver)	004-T11004-SS	1
4	Elbow	003-EL1414F	2			
5	Hose	002-9016	9ft	* Tip color subject to change		
6	Hose clamp	003-9002	11			
7	Check valve	002-4564XB	3			
8	Female disconnect	004-1207H	3			
9	Washer	004-1207W	3			
10	Tip strainer	004-1203-200	3			
11	Hose bracket	001-4720	1			
12	Female coupler	004-1207G	3			
13	Elbow	003-EL1414	4			
14	Lynch pin	008-4576	2			
15	Spray shield	001-4703G	1			
16	Shield holder	001-4703I	2			
17	Twine diverter (prox)	001-4644	1			
18	Twine diverter	001-4645	1			
19	Saddle leg	001-4703B	2			

Model 4506B Installation Kit

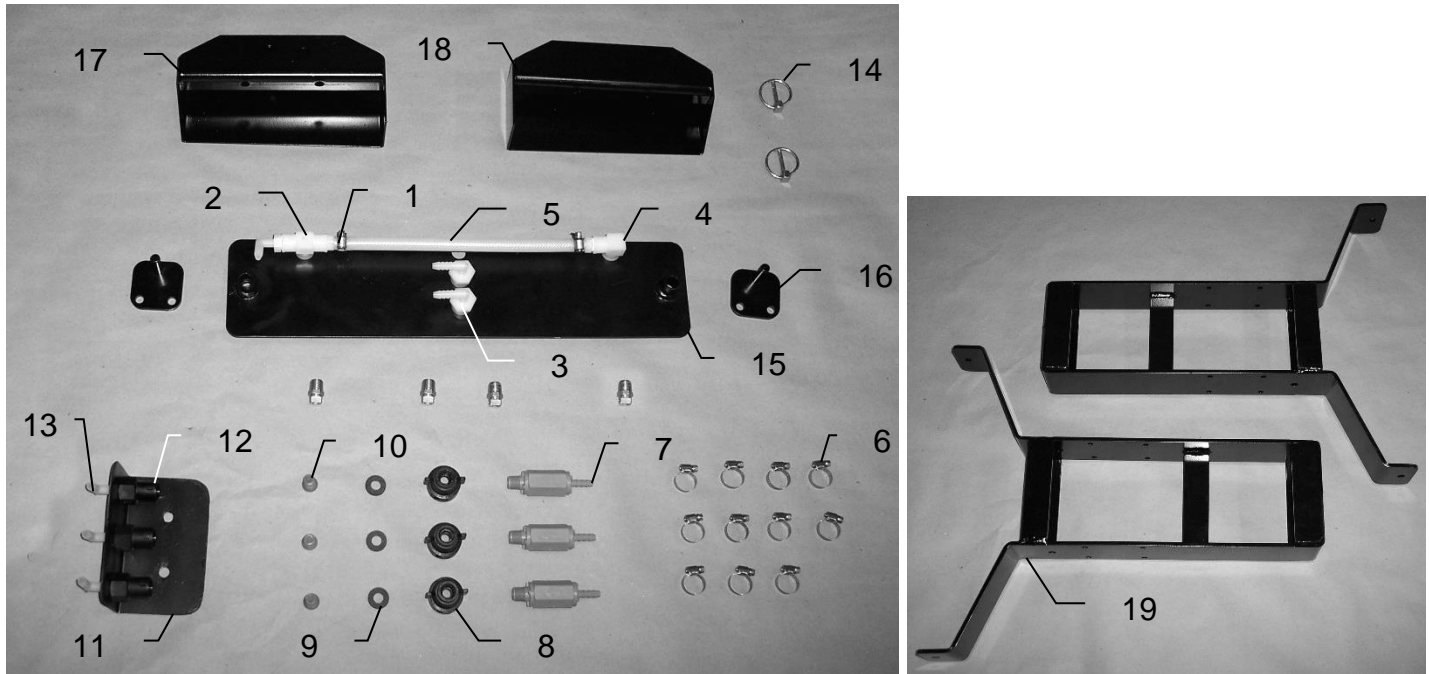

<u>Ref</u>	<u>Description</u>	<u>Part #</u>	<u>Qty</u>	<u>Description</u>	<u>Part#</u>	<u>Qty</u>
1	Straight fitting	003-A1414	2	Tip	004-T650050-SS	2
2	Tee	003-TT14SQ	1	Tip	004-T110015-SS	1
3	Elbow	003-EL1414F	2	Tip	004-T11004-SS	1
4	Elbow	003-SE14F	1			
5	Hose	002-9016	9ft	* Tip color subject to change		
6	Hose clamp	003-9002	11			
7	Check valve	002-4564XB	3			
8	Female disconnect	004-1207H	3			
9	Washer	004-1207W	3			
10	Tip strainer	004-1203-200	3			
11	Hose bracket	001-4720	1			
12	Female coupler	004-1207G	3			
13	Elbow	003-EL1414	4			
14	Lynch pin	008-4576	2			
15	Spray shield	001-4703G	1			
16	Shield holder	001-4703H	2			
17	Twine diverter (prox)	001-4644	1			
18	Twine diverter	001-4645	1			
19	Saddle leg	001-4703B	2			

Model 4507B Installation Kit - Three Tie Balers

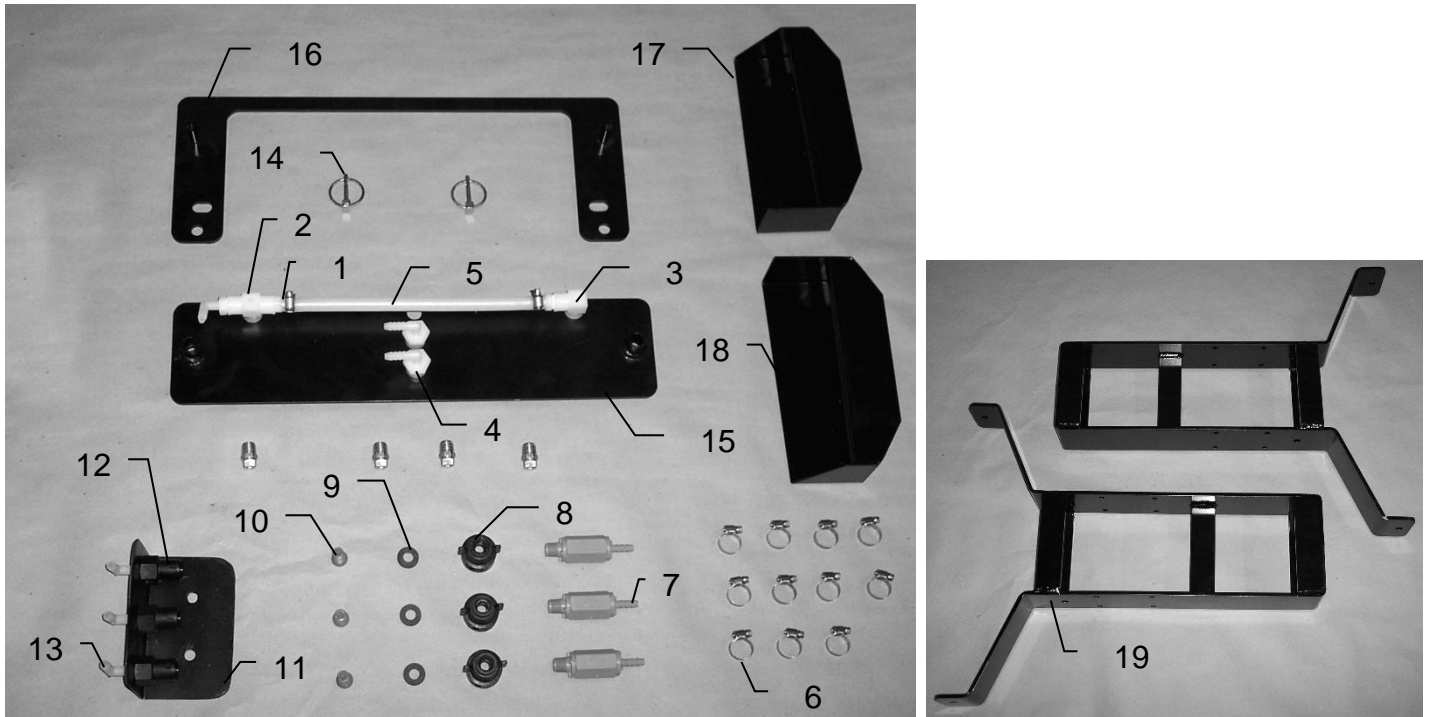

<u>Ref</u>	<u>Description</u>	<u>Part #</u>	<u>Qty</u>	<u>Description</u>	<u>Part#</u>	<u>Qty</u>
1	Straight fitting	003-A1414	2	Tip	004-T650050-SS	2
2	Tee	003-TT14SQ	1	Tip	004-T110015-SS	1
3	Elbow	003-SE14F	1	Tip	004-T11004-SS	1
4	Elbow	003-EL1414F	2			
5	Hose	002-9016	9 ft			
6	Hose clamp	003-9003	11			
7	Check valve	002-4564XB	3			
8	Female disconnect	004-1207H	3			
9	Washer	004-1207W	3			
10	Tip strainer	004-1203-200	3			
11	Hose bracket	001-4720	1			
12	Female coupler	004-1207G	3			
13	Elbow	003-EL1414	4			
14	Lynch pin	008-4576	2			
15	Spray shield	001-4703G	1			
16	Shield holder	001-4703J	1			
17	Twine diverter (prox)	001-4644	1			
18	Twine diverter	001-4645	1			
19	Saddle leg	001-4703B	2			

* Tip color subject to change

Optional iPad Mini Mounting Kit (030-2014MK)

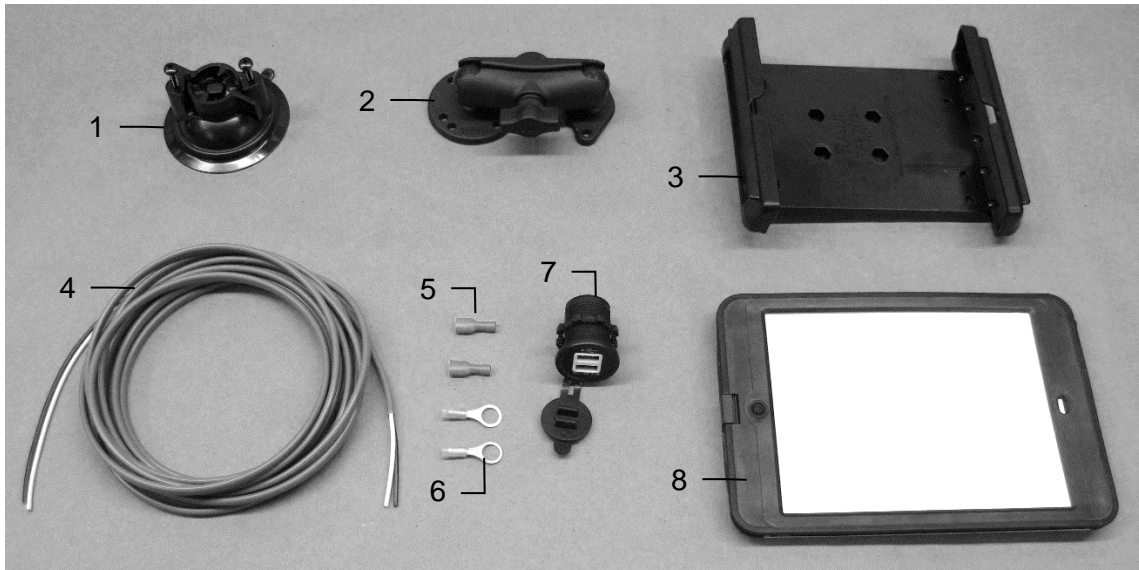

<u>Ref</u>	<u>Description</u>	<u>Part #</u>	<u>Qty</u>
1	Suction cup mount	001-2012SCM	1
2	Ram mount	001-2012H	1
3	iPad Mini® spring load cradle (Mini 4)	001-2012SLC	1
4	16 gauge power wire	006-4723P	1
5	Female spade connector	Hardware	2
6	Eye loop connector	Hardware	2
7	iPad Mini Charger 12V	001-2012P	1
8	iPad Mini 4 case	001-2012C4	1
NP	4 amp fuse	Hardware	1

Mounting Kit Assembly

030-2014MK
(Includes All Parts)

Installation Instructions

1. Identify 12V power source for wires to connect.
 - a. Eye loops included if wiring directly to the battery is desired.
 - b. Test for key power source if preferred to have power to the USB shut off with the key.
2. Once power source is identified, cut wires to desired length.
3. Crimp the two supplied quick connectors onto each the white and black wire.
4. Remove the round locking plastic nut from USB plug before connecting the wires. Black (+) White (-).
5. The wires will then be hooked to the designated terminals on the bottom of the USB plug
6. Drill a 1 1/8" hole in the preferred mounting location. Be sure to clean any sharp edges after drilling.
7. Feed the wires through the mounting hole.
8. If using the round plastic nut to secure plug in place, slide the nut back over the wiring before connecting the wires to powered source.
9. Connect the wires to the identified power source if easier to do so before tightening the plug into place.
10. Tighten plug using either the round plastic nut or mounting plate and two screws, both options supplied.
11. Once connected, hook a USB charging cord into the plug and connect a mobile device/tablet to ensure the plug is operating as you wish (key power working properly if necessary).

NOTE: This plug is not designed to charge two iPads. System damage could occur if this is attempted. System will charge a mobile phone and iPad simultaneously without problem.

*iPad mini is a trademark of Apple Inc., registered in the U.S. and other countries.

Optional iPad Display Kit (030-4670DK)

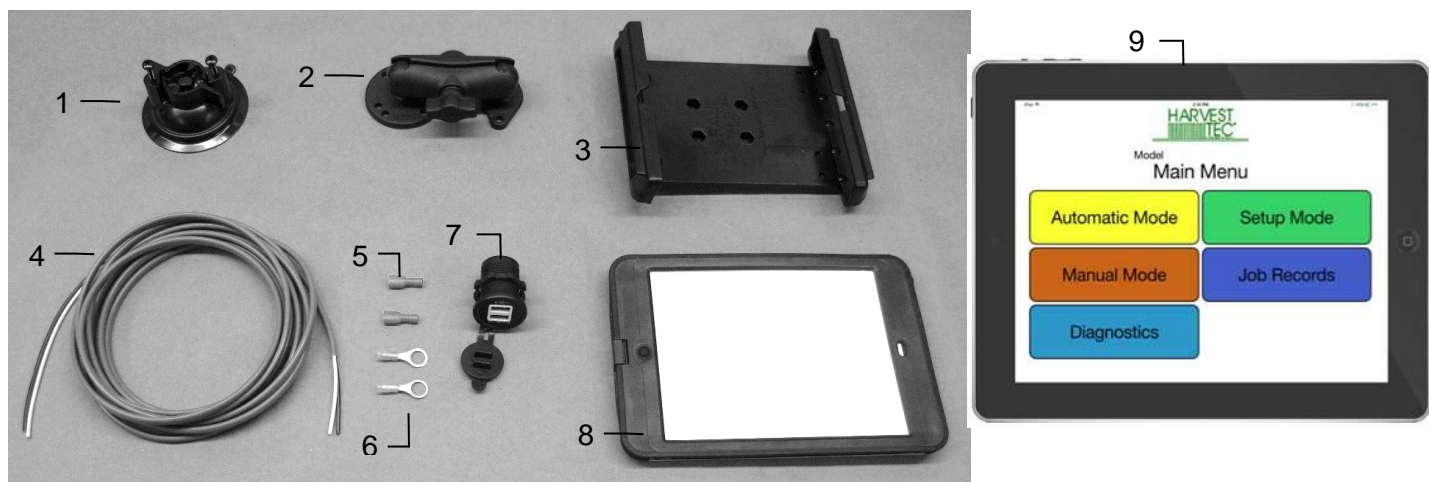

<u>Ref</u>	<u>Description</u>	<u>Part #</u>	<u>Qty</u>	<u>Ref</u>	<u>Description</u>	<u>Part #</u>	<u>Qty</u>
1	Suction cup mount	001-2012SCM	1	7	iPad Mini Charger 12V	001-2012P	1
2	Ram mount	001-2012H	1	8	iPad Mini 4 case	001-2012C4	1
3	iPad Mini® spring load cradle (Mini 4)	001-2012SLC	1	9	iPad Mini 4	006-4670IP	1
4	16 gauge power wire	006-4723P	1	NP	4 amp fuse	Hardware	1
5	Female spade connector	Hardware	2				
6	Eye loop connector	Hardware	2				
					Mounting Kit Assembly	030-4670DK (Includes All Parts)	

Installation Instructions

1. Identify 12V power source for wires to connect.
 - a. Eye loops included if wiring directly to the battery is desired.
 - b. Test for key power source if preferred to have power to the USB shut off with the key.
2. Once power source is identified, cut wires to desired length.
3. Crimp the two supplied quick connectors onto the white and black wire.
4. Remove the round locking plastic nut from USB plug before connecting the wires. Black (+) White (-).
5. The wires will then be hooked to the designated terminals on the bottom of the USB plug
6. Drill a 1 1/8" hole in the preferred mounting location. Be sure to clean any sharp edges after drilling.
7. Feed the wires through the mounting hole.
8. If using the round plastic nut to secure plug in place, slide the nut back over the wiring before connecting the wires to powered source.
9. Connect the wires to the identified power source if easier to do so before tightening the plug into place.
10. Tighten plug using either the round plastic nut or mounting plate and two screws, both options supplied.
11. Once connected, hook a USB charging cord into the plug and connect a mobile device/tablet to ensure the plug is operating as you wish (key power working properly if necessary).

NOTE: This plug is not designed to charge two iPads. System damage could occur if this is attempted. System will charge a mobile phone and iPad simultaneously without problem.

*iPad mini is a trademark of Apple Inc., registered in the U.S. and other countries.

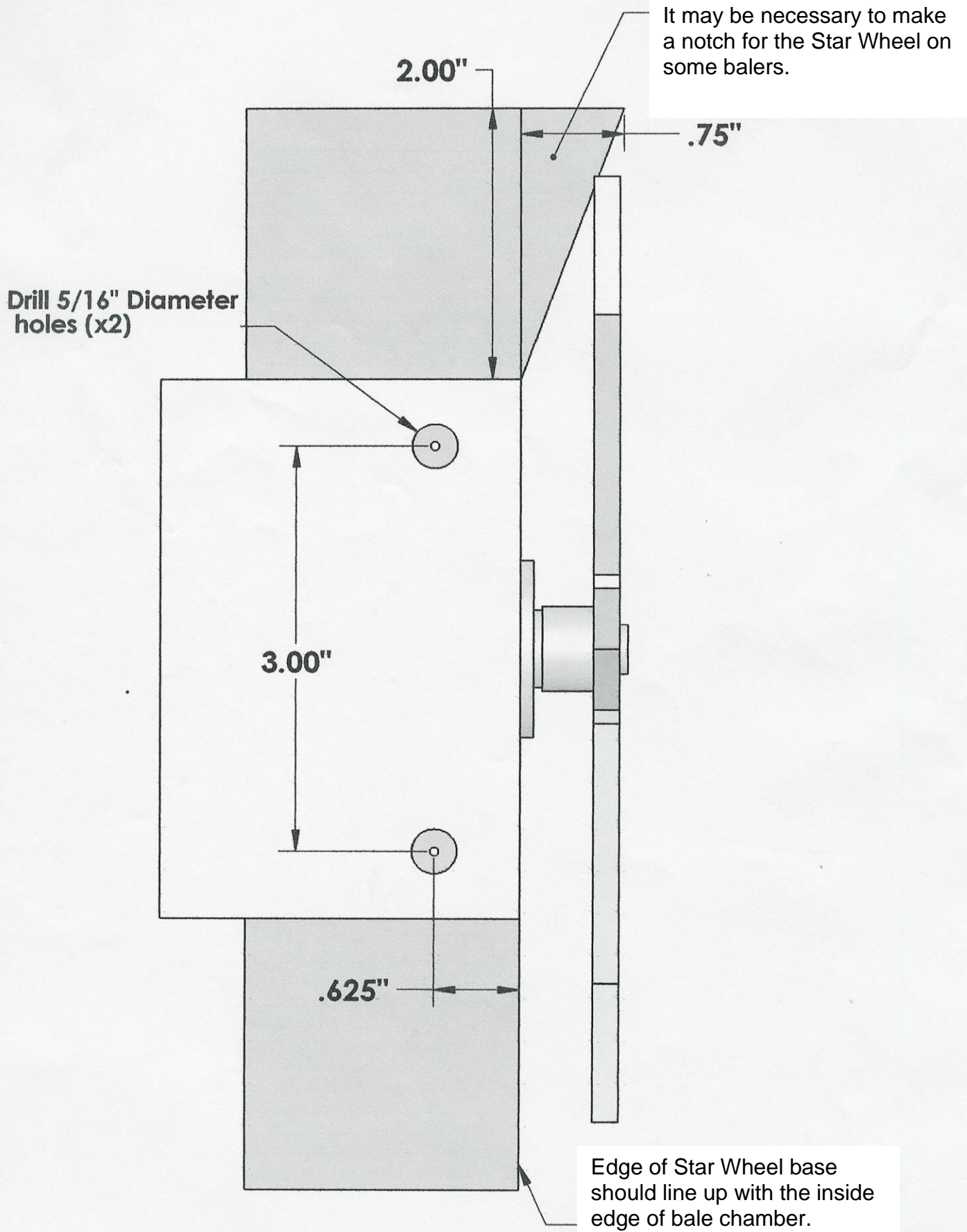

*This guide is to be used as a visual aid for star wheel installation. Exact measurements on baler are determined by operator.

← Knife

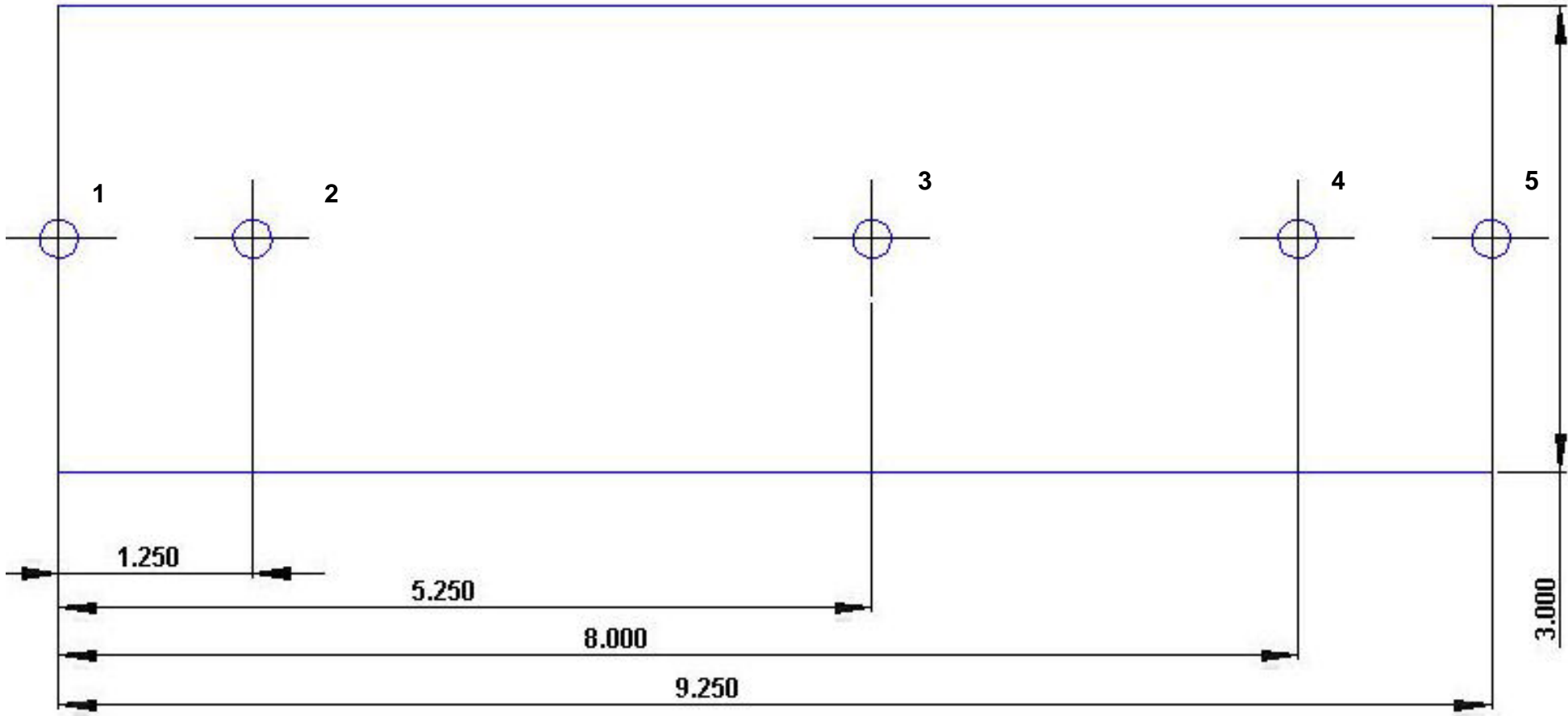

4415B Spray shield guide

*This guide is to be used as a visual aid for star wheel installation. Exact measurements on baler are determined by operator.

Notes

Notes

Harvest Tec LLC. Warranty and Liability Agreement

Harvest Tec, LLC. will repair or replace components that are found to be defective within 12 months from the date of manufacture. Under no circumstances does this warranty cover any components which in the opinion of Harvest Tec, LLC. have been subjected to negligent use, misuse, alteration, accident, or if repairs have been made with parts other than those manufactured and obtainable from Harvest Tec, LLC.

Our obligation under this warranty is limited to repairing or replacing free of charge to the original purchaser any part that in our judgment shows evidence of defective or improper workmanship, provided the part is returned to Harvest Tec, LLC. within 30 days of the failure. If it is determined that a non-Harvest Tec branded hay preservative has been used inside the Harvest Tec applicator system where the failure occurred, then Harvest Tec reserves the right to deny the warranty request at their discretion. Parts must be returned through the selling dealer and distributor, transportation charges prepaid.

This warranty shall not be interpreted to render Harvest Tec, LLC. liable for injury or damages of any kind, direct, consequential, or contingent, to persons or property. Furthermore, this warranty does not extend to loss of crop, losses caused by delays or any expense prospective profits or for any other reason. Harvest Tec, LLC. shall not be liable for any recovery greater in amount than the cost or repair of defects in workmanship.

There are no warranties, either expressed or implied, of merchantability or fitness for particular purpose intended or fitness for any other reason.

This warranty cannot guarantee that existing conditions beyond the control of Harvest Tec, LLC. will not affect our ability to obtain materials or manufacture necessary replacement parts.

Harvest Tec, LLC. reserves the right to make design changes, improve design, or change specifications, at any time without any contingent obligation to purchasers of machines and parts previously sold.

Revised 5/22

HARVEST TEC, LLC.
P.O. BOX 63
2821 HARVEY STREET
HUDSON, WI 54016
PHONE: 715-386-9100
1-800-635-7468
FAX: 715-381-1792
Email: info@harvesttec.com