

Owner's Manual

H₂O Sensor - Model 201SS & 200DM Small Square Baler Precision Moisture Sensing Kit



P.O. Box 63 • 2821 Harvey Street • Hudson, WI 54016
800-635-7468 • www.harvesttec.com

H₂O Moisture Owner's Manual Table of Contents

	<u>Page</u>
Introduction	3
Requirements & Tools Needed	3
Installation of Star Wheels	4
Two-Tie Balers	4
Three-Tie Balers	4
Control Box Installation	5
End of Bale Sensor Installation - 200FCA (Optional)	5
Dye Marker Installation - 200DM (Optional)	6
Wiring Diagram	7
Downloading H₂O App	8
Screen Definitions	8
Operation	9-11
Reading Moisture	9
Moisture Range	9
Dye Marker System	10
Dye Sprayer Override	10
H₂O Firmware Update through App	11
Pin Outs	12
Parts Breakdown	13-15
Star Wheels	13
Control Box & Harnesses	13
Fixed Chamber End of Bale Sensor Kit	14
Precision Moisture Dye Marker	15
Warranty Statement	16

Introduction

Congratulations and thank you for purchasing a Harvest Tec H₂O Moisture Sensing Kit Model 201SB system. Please read this manual carefully to ensure correct steps are taken to attach the system to the baler. This system is designed to read moisture at levels of 5-33%.

Requirements

The app will support operation of the current operating system and one previous version for both Apple and Android devices.

***It is recommended for proper communication that the original phone/tablet power cable is used. Many lower cost power cables do not meet requirements to properly charge and communicate to the Harvest Tec H₂O module.*

Tools Needed

SAE wrench set
Standard screw driver
Side cutter

Hammer
Measuring tape
SAE socket set

Drill bit set
Center punch

Installation of Star Wheels

Two-Tie Balers Only

The pair of star wheels will need to mount on the bottom side as close to the front of the bale chute as possible and at least 3/8" (10mm) away from any metal. They will need to maintain a safe distance away from the twine.

Depending on the baler model the star wheels can mount in front of the needle arm Option A (below) if there is space available. When there is not enough room for the star wheel use Option B

The star wheels will require two holes to be drilled per block, when drilling make sure to keep the wheel square to the bale chamber. Any angle will cause stress on the wheel and will eventually cause the wheel to work itself out of the block. Some balers may require a notch cut on the bottom of the bale chamber to mount the star wheels as close to the front of the chamber as possible.

Use the supplied bolts and place the head inside of the bale chamber. Next attach 001-6707ES to the outside of the chamber. Then attach the star wheels to the bolts followed by the flat washer, lock washer, and nut.

First, remove the cover from the star wheel block and use a 1/4" (7mm) nut driver to remove the nut from the electronic swivel. Next, run the star wheel sensor wire through the black grommet and place the eye terminal on the star wheel sensor. Tighten the eye loop with the nut on the sensor and put the star wheel cover back on the base. Next, tighten the grommet to form a tight seal around the wire. Secure the harness to the baler to avoid moving parts.

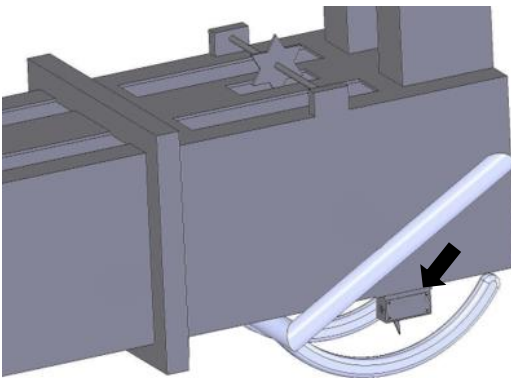

Option A

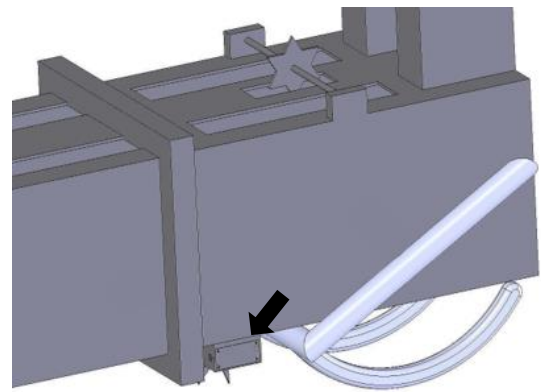

Option B

Three-Tie Balers Only

When using a three-tie baler the star wheels will need to be mounted on the top of the bale chamber as close to the knotters as possible (shown below). Use the instructions above for proper star wheel installation.



Control Box Installation

Locate a safe location in the cab of the tractor to place the control box (006-2473RB) in a location to connect a USB cable ending in a USB-A plug to connect to display device.

Connect the Power Harness (006-2470P) and the Baler Power Communication Harness (006-2470SS).

The control box (006-2473SB) is equipped with a green light to indicated both power and connection.

Plug the tablet/phone cord into the communication port (closest to light) and indicated by:

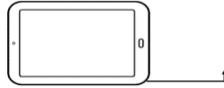

006-2473SB

Slow Blink – System has power but not connected to phone or tablet.

Solid Green – Device is connected.

*** It is recommended for proper communication that the original phone/tablet power cable is used. Many lower cost power cables do not meet requirements to properly charge and communicate to the Harvest Tec H2O module.*

End of Bale Sensor Installation – 200FCA (Optional)

The end of bale sensor is used to determine when the baler needle arm moves. With this information the system is able to show the average moisture of the previous bale. Part number for kit is 200FCA

Mount the 006-7400 sensor to the mounting bracket 001-4648RB as shown below. Mount the assembly on the right side of the baler chamber. The face of the sensor needs to be parallel to the arm attached to the needles.

*Note: The bracket may need to be slightly bent for the proper positioning.

Mark and drill two 3/8" (10mm) holes. Install the sensor using two 5/16" x 1" allen head bolts, locks, and nuts. The end of the sensor needs to be no greater than 1/4" (7mm) away from the needle arm. Tighten nuts on sensor after adjustment.

The harness will need to be routed toward the harness at the tongue of the baler. Secure with cable ties and take care to avoid pinch points. The harness extension (006-7400EXT) may need to be used.

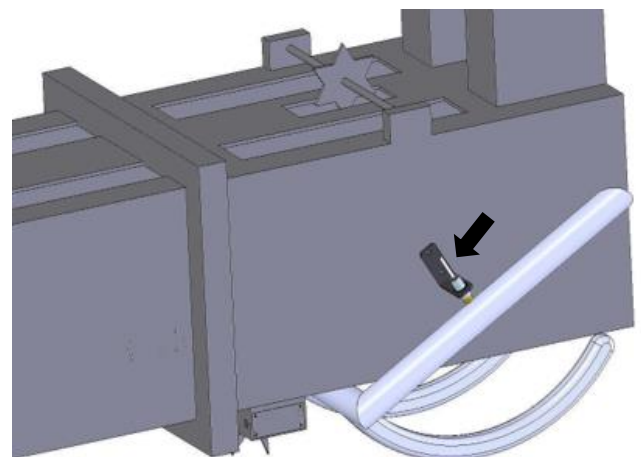
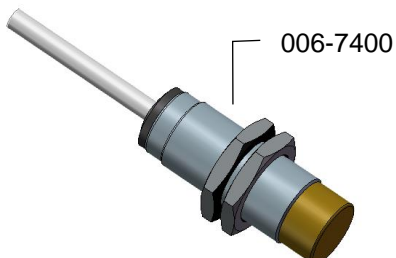
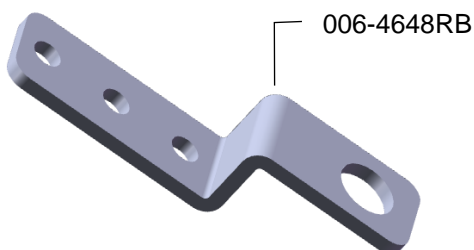

Dye Marker Installation – 200DM (Optional)

Locate the dye marking kit tank and pump assembly (005-9015). Identify a suitable mounting location for the tank away from moving parts and hydraulic lines on the baler. Be sure to mount the tank within 10' of the connection on the Baler Pwr/Comm Harness (006-2470SS), wiring details in the wiring diagram.

Note: The mounting location will potentially be different for the tank on each baler model. Due to various baler designs and modifications, Harvest Tec does not offer a specific mounting location for each baler model.

Once a mounting location has been identified, mount the tank vertically as shown (right) with the tank lid on the top using the included hardware.

Next locate the dye marking spray assemblies shown (below).



Nozzle straps should be placed directly above star wheels so spray will be applied on the top of the bale in the twine grooves.

***Small square and Large square balers must use the brass tip (004-TX-5)**

Mount the second tip assembly on the left side of the baler in a similar position to allow the tip to spray the bale.

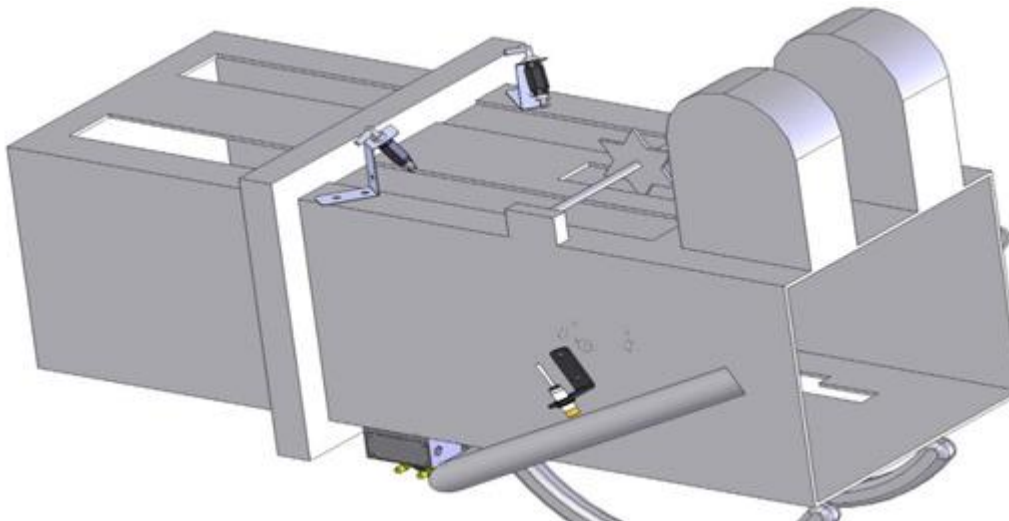

Routing the Hose

Using the supplied 1/4" hose (002-9006) connect to the pump and secure with the hose clamps (003-9002). Route the hose to each tip assembly by using the 1/4" Barbed Tee (003-T1414) to go to each side of the baler. Be sure to avoid moving parts.

Wiring Diagram

1. Connect the power harness (006-2470P) to the tractor convenience outlet keyed power switch using the red wire with fuse to the positive side and the black wire to the negative.
 - a. Any modifications of the power harness will void the warranty. Contact Harvest Tec before modifications are made.
2. The power harness (006-2470P) will mount on the tractor connected to the control box (006-2473SB) with the 12-pin male deutsch connection and the opposite end down to the draw bar.
3. Connect the Baler Pwr/Comm Harness (006-2470SB) to the power harness (006-2470P).
4. Route the Pwr/Comm Harness (006-2470SS) on the baler to each moisture sensor on both sides of bale chamber, sensors are pn 030-4642UX.
5. Connect the USB charging/comm cord for the phone or tablet being used to that device and the 201 control box (006-2473SB).
6. When using a Dye Marker, the End of Bale Sensor kit will need to be added to the system in order to see when needle arm cycles. Part number (200FCA). Connect the sensor to the End of Bale (EOB) connection on the Baler Pwr/Comm Harness (006-2470SS).
7. When using the optional Dye Marker (200DM) connect 4 pin round end of the H2O harness (006-2470C) to the Dye Marker (DM) connection on the (006-2470SS) harness. Then connect the two straight spade connections with only the white wire to the push switch (006-2850). The remaining two connections with 90-degree female spades will connect to the pump.

System wiring diagram

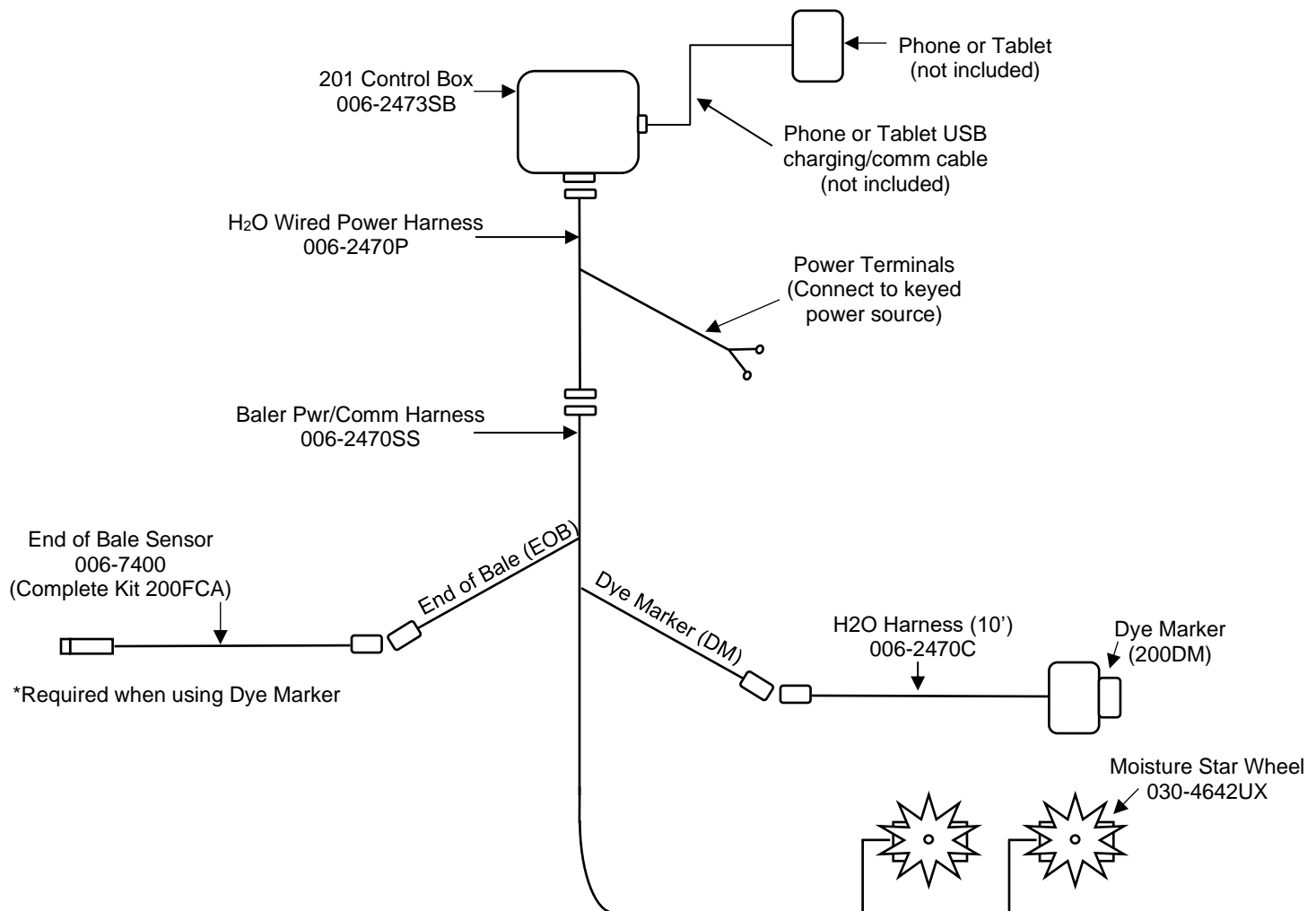

*If needed an optional 8' Pwr/Comm harness extension is available (not included), part number 006-2470BL2.

Downloading H₂O App

The H₂O App is available on any Apple or Android device running with the current operating system software and one previous version. Download the app by searching for H₂O Sensor. App icon shown right.



Screen Definitions

Main Screen

Brightness Adjustment – Tap to switch between day and night time brightness

Current Moisture Reading – Information will display once hay enters the bale chamber

Current App Version (example)

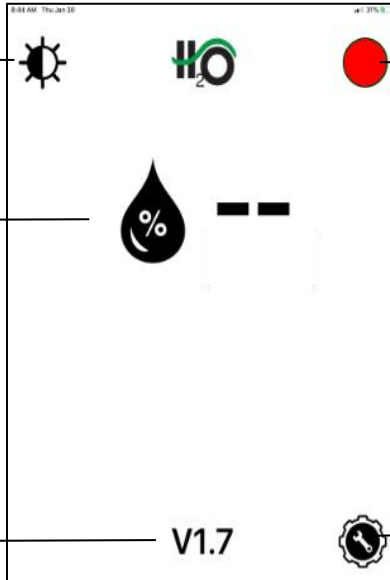

Connection Signal - When connection is made with the control box light will turn Green

Red – Not Connected
Green - Connected

Settings Tab – Select to switch to Settings Screen

Settings Screen

Dye Marker System

Home Tab – Select to change to Home Screen

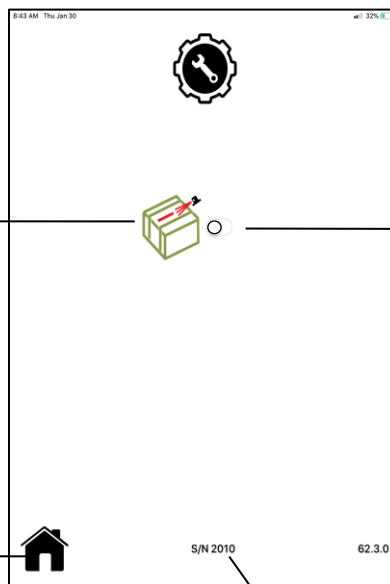

On / Off Slide – Slide to the right to turn On Setting. The bar will turn red or green (dependent on device)

App Version

Serial Number of System

Operation

After installation of the H₂O app, turn the system on by turning the key in the tractor on. When the connection is made the green light on the control box will illuminate.

Reading Moisture

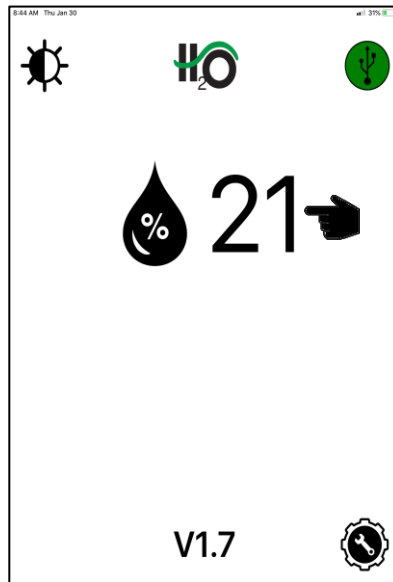

When hay begins to enter the bale chamber,
current moisture will be displayed

Moisture Range 5-33%

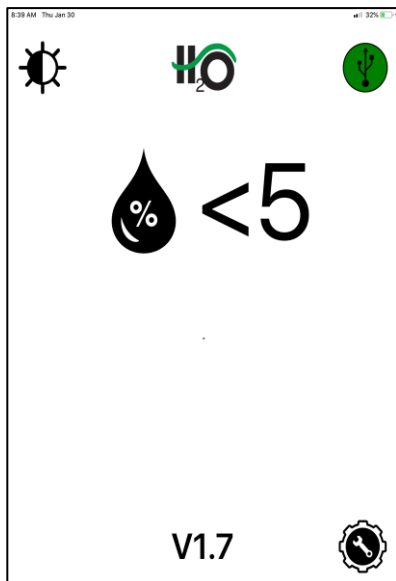

If the moisture being read is Less Than 5% the
reading will appear as shown above

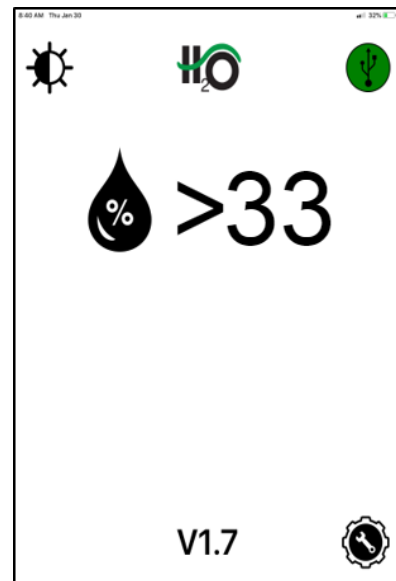

If the moisture being read is Greater Than 33%
the reading will appear as shown above

Operation (continued)

Dye Marker System

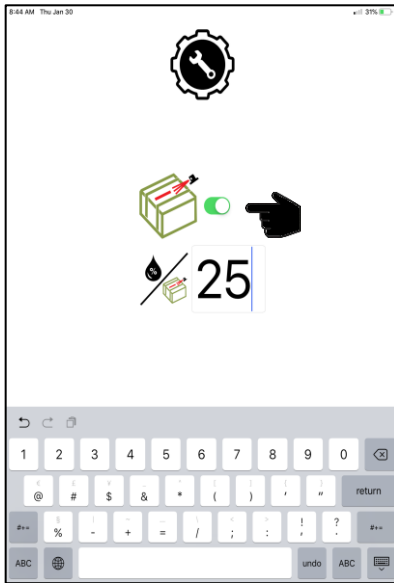

When using the dye marker turn on the setting as shown and select the desired moisture to mark a bale.
*Bales at or above this moisture level will be marked.

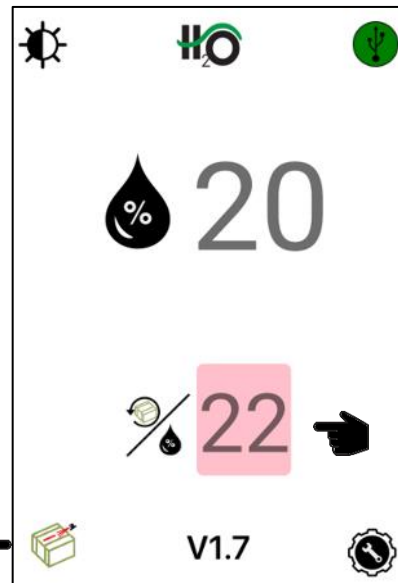

Dye Marker icon will now appear on the home screen. The last bale moisture will be highlighted in red and the bale will be marked at or above the set moisture.

Dye Marker Notes

- When the Dye Marker is activated by the moisture setting it will spray 3 seconds once per End of Bale (EOB) cycle. After an EOB signal the dye marker is then reset to be able to spray again for 3 seconds once on the next bale.
- A full tank of dye is estimated to mark 50-60 bales.

Dye Marker Override

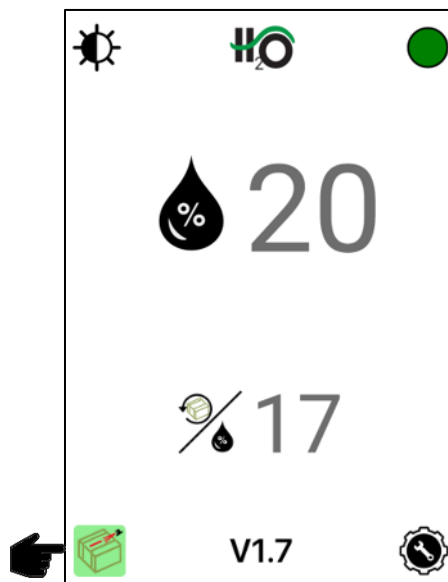

If you would like to mark a bale for any reason, press the bale icon which will cause it to turn green. When the manual override is used the last bale moisture will not highlight in red.

The manual spray function can be used on a bale as many times as preferred in 3 second intervals.

H2O Firmware Update through App

When there is an update available for the H₂O system the following information will appear, and the steps listed will need to be followed.

Once an operator downloads the app update (internet connection required) the “update available” symbol will appear along with the version number of the available update once connected to the system.

At this point the system can run without updating if the operator chooses. The icon will simply remain on the screen.

Once the operator decides to perform the software update, they will press the version number or upload arrow to begin. Internet connection is not required to perform the update to the module once the app is downloaded

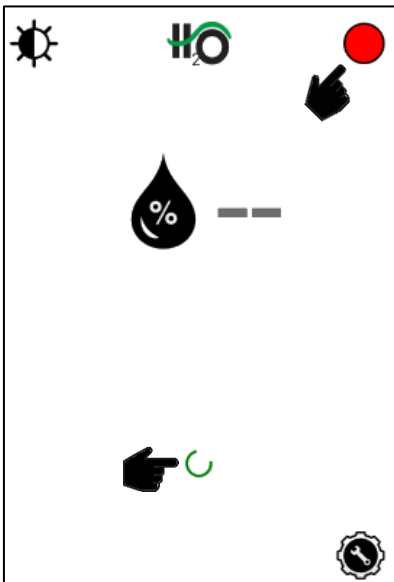
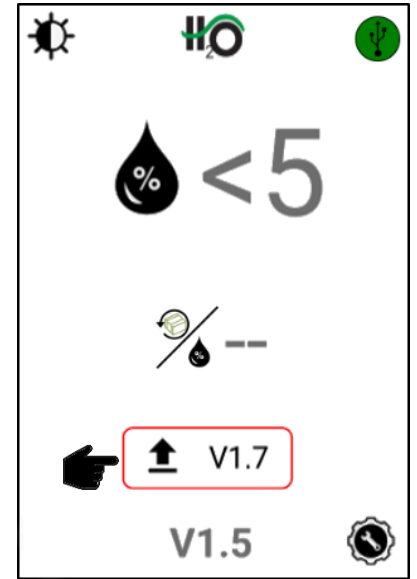

Once the update is initiated, the system will enter update mode

The status light will turn red

A green loading symbol will begin to circulate on the screen

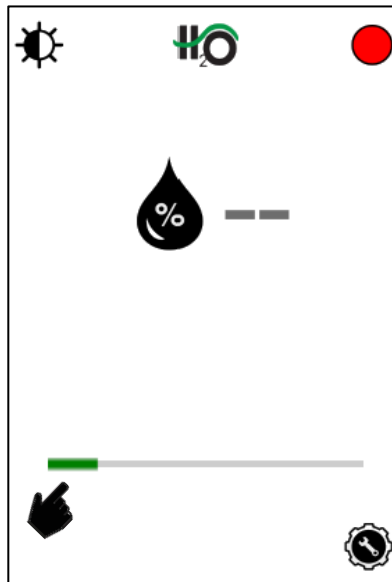

A status bar with then appear to show the update progress

This can take 3-5 minutes to load software

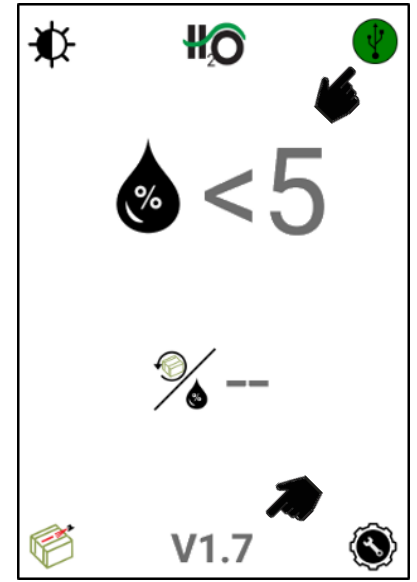

Once the status bar load completely, the system will boot back up

The status light will again turn green

The updated version number will be shown at the bottom of the screen

**** It is recommended for proper communication that the original phone/tablet power cable is used. Many lower cost power cables do not meet requirements to properly charge and communicate to the Harvest Tec H₂O module.**

Pin Outs

H2O Tractor Module 006-2473SB

Pin 1	Red	Module Power
Pin 2	Red/Black	EOB +
Pin 3	Black	EOB -
Pin 4	Grey	Left Moisture Sensor
Pin 5	Brown	Right Moisture Sensor
Pin 6	Purple	EOB Signal
Pin 7	Yellow	CAN +
Pin 8	Green	CAN -
Pin 9	Red/White	Dye Marker 12V +
Pin 10	Black/White	Dye Marker 12V -
Pin 11	Blue	Dye Marker Prime
Pin 12	Black	Ground

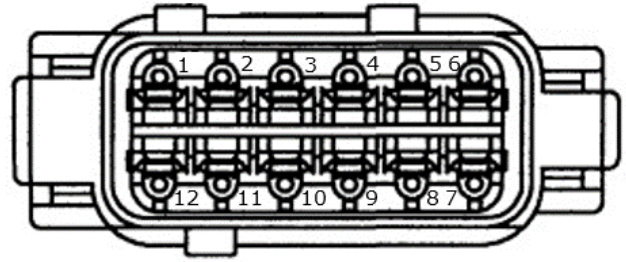

H2O Tractor Harness 006-2470P at Module Plug

Pin 1	Red	Module Power
Pin 2	Red/Black	EOB +
Pin 3	Black	EOB -
Pin 4	Grey	Left Moisture Sensor
Pin 5	Brown	Right Moisture Sensor
Pin 6	Purple	EOB Signal
Pin 7	Yellow	Not Used
Pin 8	Green	Not Used
Pin 9	Red/White	Dye Marker 12V +
Pin 10	Black/White	Dye Marker 12V -
Pin 11	Blue	Dye Marker Prime
Pin 12	Black	Ground

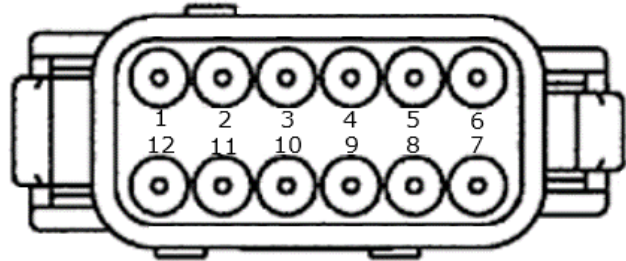

Baler Communication Harness 006-2470SS at hitch

Pin 1	Red/Black	EOB +
Pin 2	Black	EOB -
Pin 3	Grey	Left Moisture Sensor
Pin 4	Brown	Right Moisture Sensor
Pin 5	Purple	EOB Signal
Pin 6	Red/White	Dye Marker 12V +
Pin 7	Black/White	Dye Marker 12V -
Pin 8	Blue	Dye Marker Prime

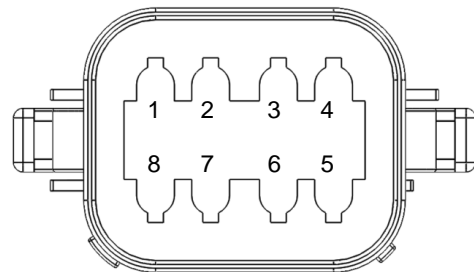

End of Bale Sensor (EOB) 006-2471B

Pin 1	Brown	EOB +
Pin 2	Blue	EOB -
Pin 3	N/A	Not Used
Pin 4	Black	EOB Signal

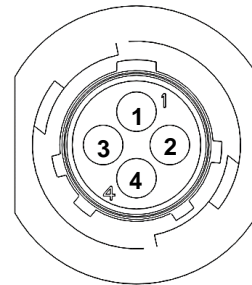

Dye Marker H2O Harness 006-2470C

Pin 1	Red	DS +
Pin 2	Black	DS -
Pin 3	White	DS Prime
Pin 4	N/A	Not Used

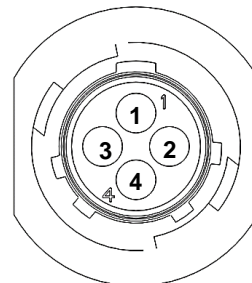

Parts Breakdowns Star Wheel assembly 030-4642UX

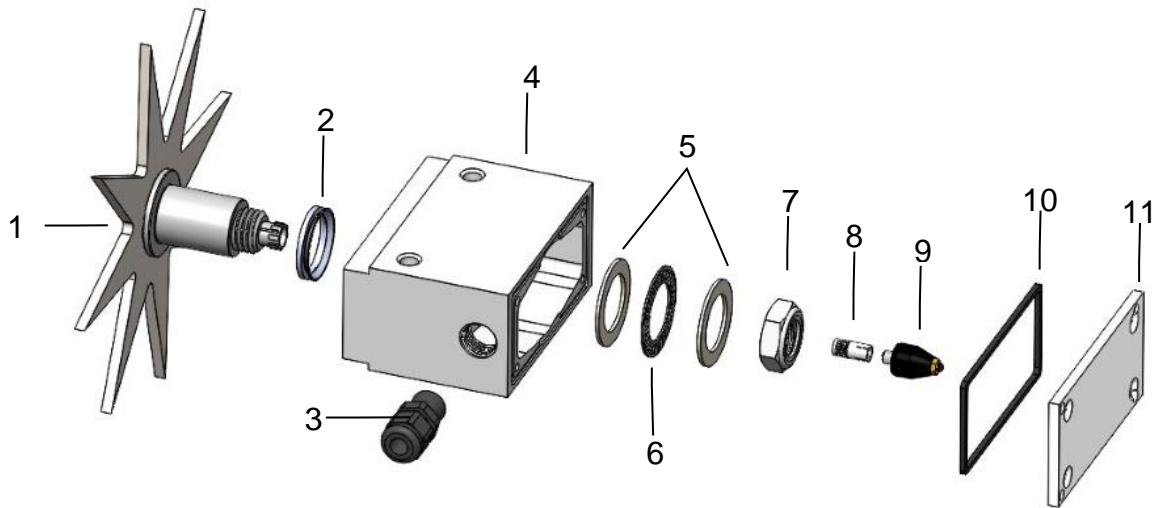

<u>Ref</u>	<u>Description</u>	<u>Part#</u>	<u>Qty</u>
1	Star Wheel with insert (includes 1, 8, & hardware)	006-4642US	1
	Hardware Kit (items 2,5,6,7)	006-4642UK	
2	Dust Seal Gasket (some pre 2024 blocks use 2 seals)	006-4642UG	1
	Spacer (used in some pre 2024 blocks)	006-4642UBS	1
3	3/8" Wiring Grommet	008-0821A	1
	3/8" Wiring Grommet Nut	008-0821B	1
4	Block (available in 2024 style only)	006-4642UB	1
5	Thrust Washer	006-4642TA	2
6	Thrust Bearing	006-4642TB	1
7	3/4" Short Nut	006-4642U	1
8	Swivel Insert	006-4642B	1
9	Rotary Swivel	006-4642A	1
10	Star Wheel Block Gasket- for 2024 block style	006-4642UG2	1
	Star Wheel Block Gasket- for pre 2024 blocks	006-4642UG	
11	Block Cover- for 2024 block style	006-4642UC2	1
	Block Cover- for pre 2024 block style	006-4642UC	
	Complete Star Wheel Assembly	030-4642UX	2

Optional* Twine Guard Diverter-Left
Optional* Twine Guard Diverter-Right

001-4645
001-4644

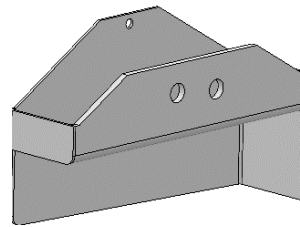
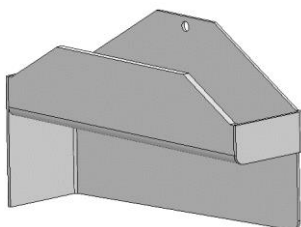

*Can be added if twine excessively makes contact with star wheels

Control Box & Harnesses

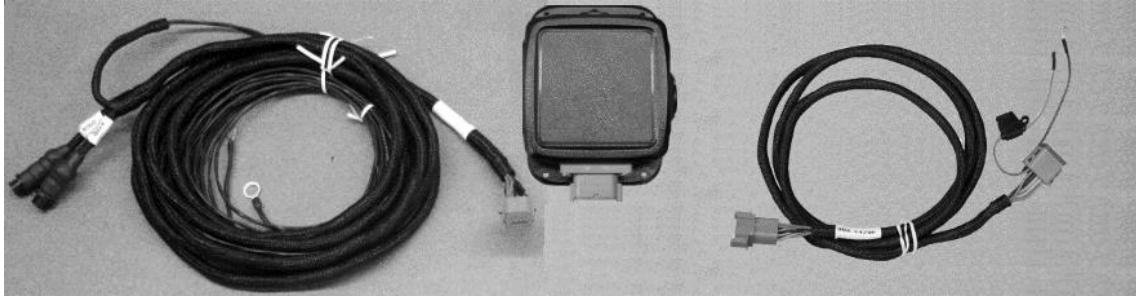

<u>Ref</u>	<u>Description</u>	<u>Part #</u>	<u>Qty</u>
1	Baler Pwr/Comm Harness	006-2470SS	1
2	201 Series Control Box	006-2473SB	1
3	Tractor Power Harness	006-2470P	1
	Optional 8' power/comm harness extension	006-2470BL2	

Fixed Chamber End of Bale Sensor Kit

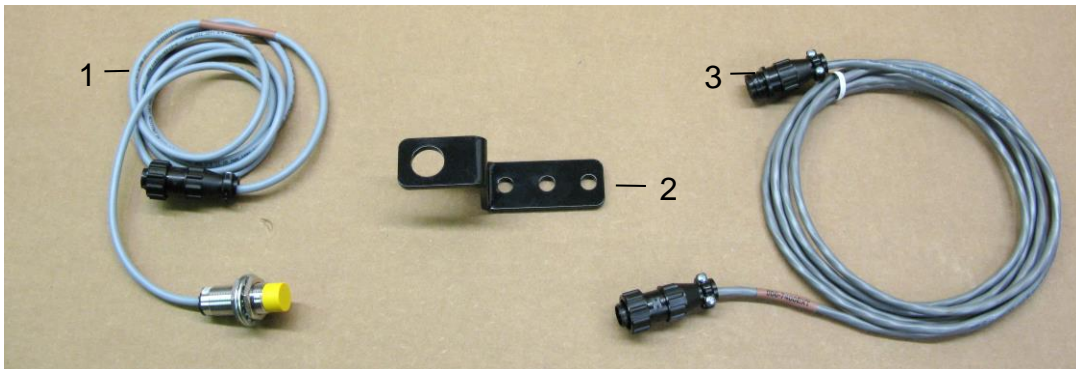

<u>Ref</u>	<u>Description</u>	<u>Part #</u>	<u>Qty</u>	<u>Ref</u>	<u>Description</u>	<u>Part #</u>	<u>Qty</u>
1	End of Bale Sensor	006-7400	1	3	EOB Extension Complete Kit	006-7400EXT 200FCA	1
2	End of Bale Bracket	001-4648RB	1				

H₂O Dye Marker

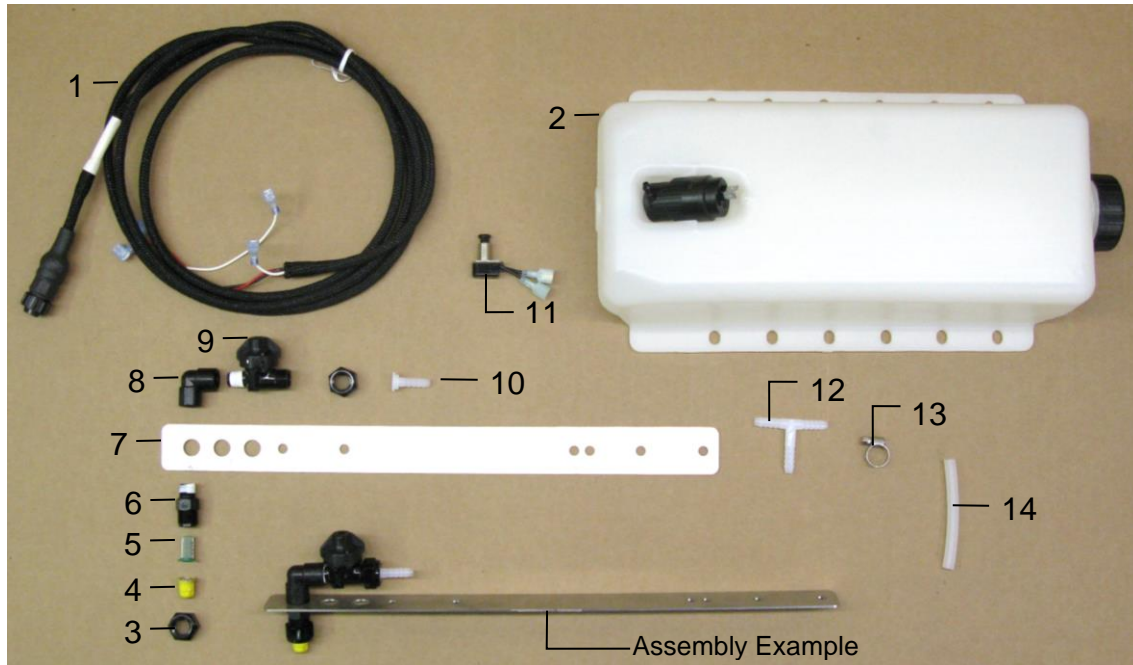

<u>Ref</u>	<u>Description</u>	<u>Part #</u>	<u>Qty</u>	<u>Ref</u>	<u>Description</u>	<u>Part #</u>	<u>Qty</u>
1	H2O Harness (10')	006-2470C	1	8	1/4" Street Elbow	003-SE14F	2
2	Tank & Pump	005-9015	1	9	Check Valve	007-1207VB	2
3	Nozzle Cap	004-4723	4	10	1/4" Straight Fitting	003-A1414VB	2
4	Tip - Brass	004-TX-5	2	11	Push Switch	006-2850	1
5	Tip Strainer (Green)	004-1203-100	2	12	1/4" All Barb Tee	003-T1414	1
6	Nozzle Body	004-4722	2	13	Mini Hose Clamp	003-9002	6
7	Nozzle Holder	001-4215	2	14	1/4" Hose	002-9006	40
				NP	Red Dye	009-0800	1
				NP	End of Bale Sensor Kit	200FCA	1
					Complete Assembly	030-200DM	

Harvest Tec LLC. Warranty and Liability Agreement

Harvest Tec, LLC. will repair or replace components that are found to be defective within 12 months from the date of manufacture. Under no circumstances does this warranty cover any components which in the opinion of Harvest Tec, LLC. have been subjected to negligent use, misuse, alteration, accident, or if repairs have been made with parts other than those manufactured and obtainable from Harvest Tec, LLC.

Our obligation under this warranty is limited to repairing or replacing free of charge to the original purchaser any part that in our judgment shows evidence of defective or improper workmanship, provided the part is returned to Harvest Tec, LLC. within 30 days of the failure. If it is determined that a non-Harvest Tec branded hay preservative has been used inside the Harvest Tec applicator system where the failure occurred, then Harvest Tec reserves the right to deny the warranty request at their discretion. Parts must be returned through the selling dealer and distributor, transportation charges prepaid.

This warranty shall not be interpreted to render Harvest Tec, LLC. liable for injury or damages of any kind, direct, consequential, or contingent, to persons or property. Furthermore, this warranty does not extend to loss of crop, losses caused by delays or any expense prospective profits or for any other reason. Harvest Tec, LLC. shall not be liable for any recovery greater in amount than the cost or repair of defects in workmanship.

There are no warranties, either expressed or implied, of merchantability or fitness for particular purpose intended or fitness for any other reason.

This warranty cannot guarantee that existing conditions beyond the control of Harvest Tec, LLC. will not affect our ability to obtain materials or manufacture necessary replacement parts.

Harvest Tec, LLC. reserves the right to make design changes, improve design, or change specifications, at any time without any contingent obligation to purchasers of machines and parts previously sold.

Revised 6/22

HARVEST TEC, LLC.
P.O. BOX 63
2821 HARVEY STREET
HUDSON, WI 54016 USA
PHONE: 715-386-9100
FAX: 715-381-1792
Email: info@harvesttec.com