

Wiring Diagram

- The Baler Power/Communication Harness (006-6650LS) will attach to the open port of the Tractor Harness (006-6650TM(E)) and run back to the Dual Channel Processor (006-6671LS). Connect the large plug of the Baler Power/Communication Harness (006-6650LS) to the bottom (shorter side) of the DCP.
 - Attach the Baler Interface Harness (006-6650VA) in between the short whip cable hardwired to the DCP and the main Power/Communication Harness (006-6650LS). Make sure Active Terminator removed from the top of the baler processor is attached to Baler Interface Harness (006-6650VA).
 - Install green terminator (006-5650Z) to the port labeled Modular Port on the Pump Controller (006-5672).
 - Attach moisture and bale rate harness (006-7303HX) as well as the end of bale harness (006-7400BBEXT) to the DCP (006-6671LS).
 - Attach the Pump Control Harness (006-5650F3M(E)) between the Pump Controller (006-5672) and the DCP (006-6671LS).
 - Connect Keyed Power Extension harness (006-5650K) to a keyed power source.
 - Connect the iPad Integration Control (030-6672C) to the Communication Harness (006-6650TM).
- Note: The Optional Port and the Data Transfer Port are not used in this application.

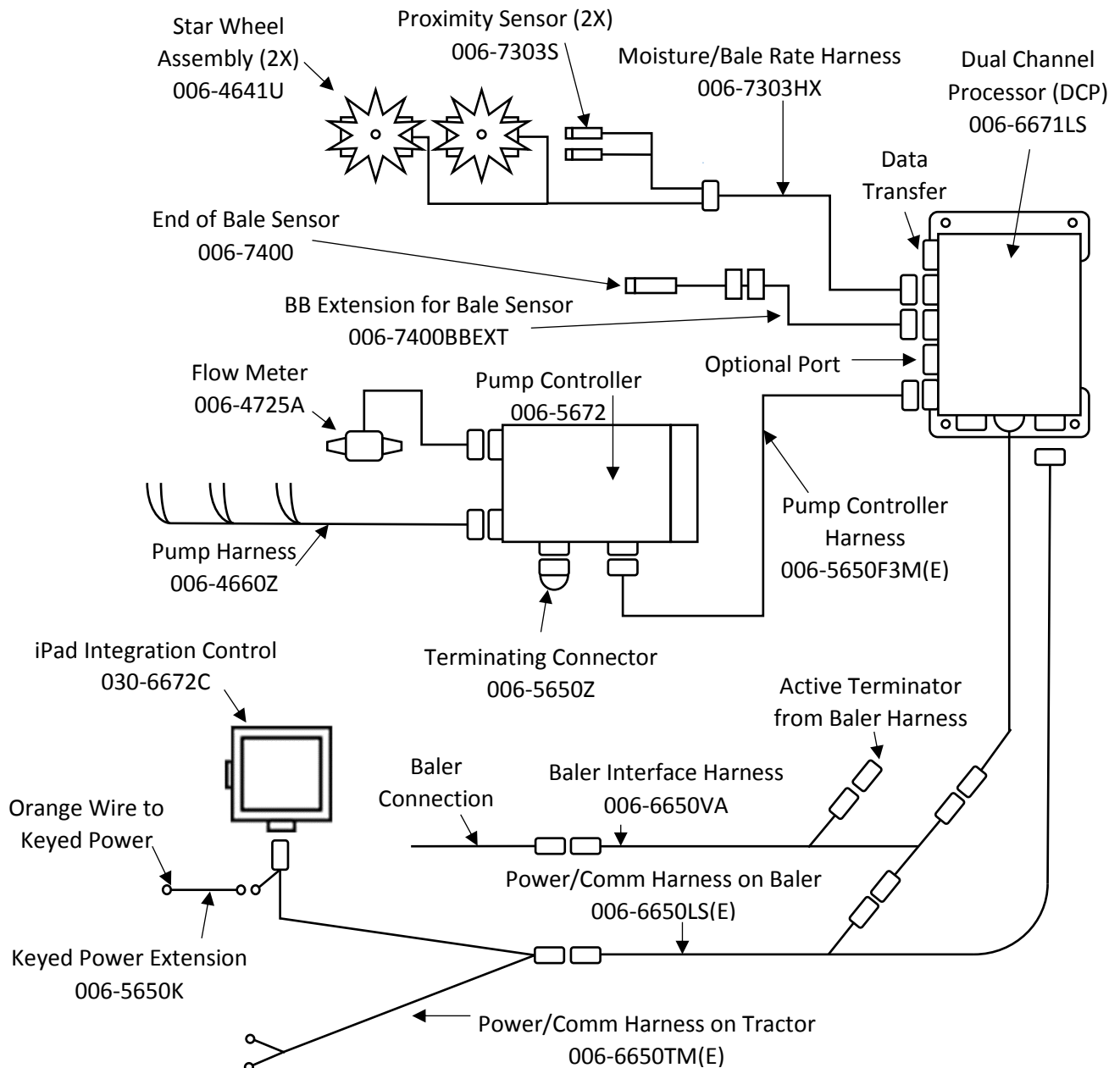

*Note: (E) indication is used for International Dealers