

OWNER'S MANUAL

Model 676
For John Deere 7000 Series

HARVEST
**TEC** *Equipment and Products
for Quality Hay.*

Harvest Tec 676 Table of Contents

	<u>Page</u>
Installation Instructions	3-8
1. Installation of Tank and Frame	3-4
2. Pump Mounting	4
3. Mounting the Gauge	4
4. Plumbing	4
Weight Distribution Chart	5
5. Mounting the Spout Nozzle Assembly (Optional)	6
6. Feed Roll	6
7. Installation of the Lower Chute – Chute Lube Bar	7
8. Connecting the Spout, Feed Roll and Chute Nozzle	7
9. Wiring of Controls	8
Operating Instructions	8
Application Instructions	9
Routine Maintenance	9
Winter Storage	9
Troubleshooting	10
Parts Breakdown	11-14
Saddle and Tank	11
Gauge, Control Box, Pump	12
Installation Kit	13
Optional Spout Nozzle Assembly	14
Warranty	15

***ADVISEMENT: TO PULL CARTS OR WAGONS JOHN DEERE PART# AZ54483
WEIGHT BRACKET MUST BE ORDERED.***

Tools Needed

- Standard wrench set
- Standard socket set
- Standard screw driver or 5/16" nut driver
- Side cutter
- Hose cutter
- Crescent wrench
- Hammer
- Metal drilling and cutting tools

Installation Instructions for John Deere 7000 Series

1. Installation of Tank and Frame

Warning: This tank and frame will only fit John Deere 7000 Series Self-Propelled Forage Harvesters

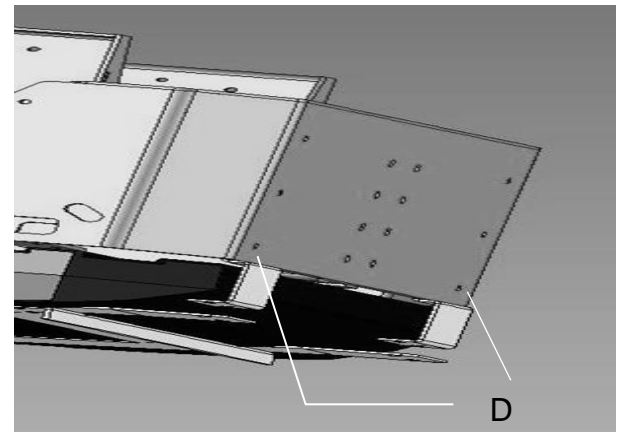
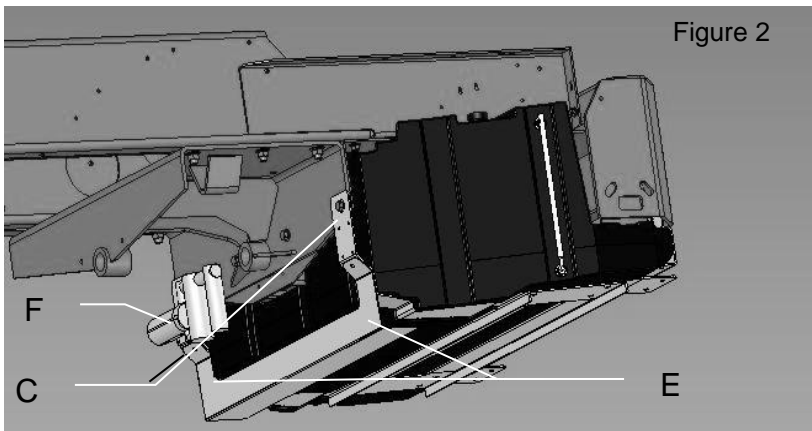
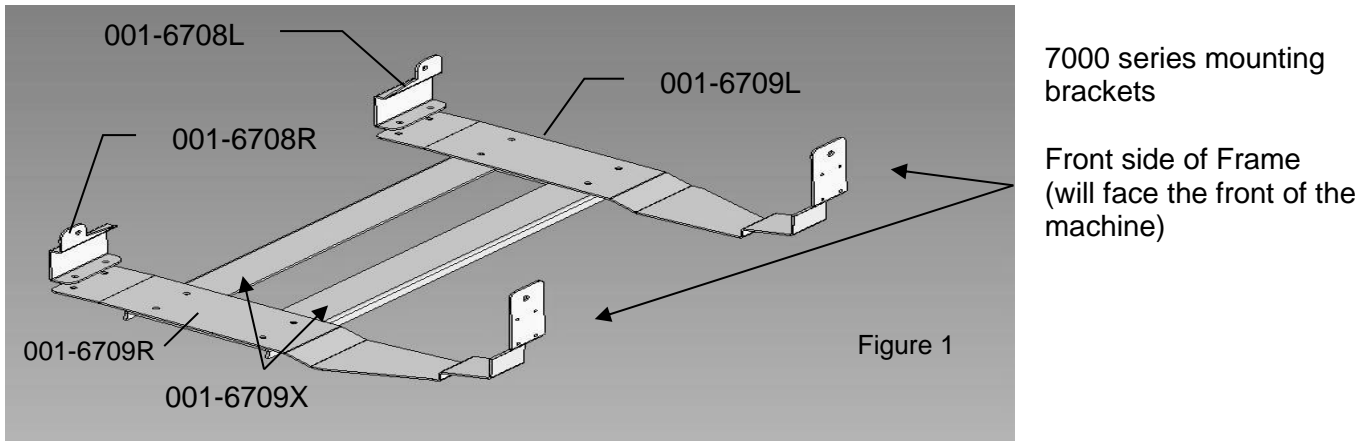

1. Position parts 001-6708R and 001-6708L over parts 001-6709R and 001-6709L as indicated in Figure 1. Fasten the parts together loosely using the 10mm X 100mm bolts and hardware in the parts bag.
2. Position the tank on top of the brackets with the fill spout to the left side of the machine.
3. To prepare the harvester for tank installation, remove the outside bolt and nut from each side of the front mounting plate in Figure 2 (letter C).
4. Tank installation: Remove the hitch plate from where it is mounted to the bottom of the frame. If the machine is used to pull wagons, a weight carrier must be purchased through your John Deere dealer. This weight carrier may also be required to correctly ballast the machine. (See weight distribution chart, page 5.)
 - a. If there is a suitcase weight bracket attached to the rear of the harvester remove the bottom bolt on each side. (letter D, figure 3)
5. Mounting the tank and frame to the harvester will require three people, two to lift the tank and one to mount the frame.
6. Begin by raising the tank and frame so 001-6708R and 001-6708L are on the inside of the rear bumper. Insert the 12 mm bolts, lock washers and flat washers through the back of the bumper and thread into the weld nuts on 001-6708L and 001-6708R. **DO NOT FULLY TIGHTEN YET.**
7. Raise the front on the mounting bracket so it is on the front side of the plate (C in figure 2). Install the official hardware to fasten the front of the mounting brackets.
8. Center the tank to the machine and push it forward.
9. Tighten the 12mm bolts extending through the rear to 87ft. lbs.

Installation of Tank and Frame (continued)

10. Retighten the existing hardware on the front side plate.
11. Begin tightening the 10mm bolts connecting 001-6708L to 001-6709L and 001-6708R to 001-6709R switching from side to side until the tank is secure. Once all of the bolts are tight, cut off the excess thread on the 10mmX100mm bolt with a hacksaw.
12. The stalk protector will be mounted on the front side of the tank (using 10mmX30mm bolts and hardware) shown in figure 2 reference E.

2. Pump Mounting

The pump will be mounted as shown in Figure 2 reference number F. Mount the pump with the provided bolts and nuts.

3. Mounting the Gauge

The gauge must be mounted in a location easily visible to operator from the cab. The gauge should also not interfere with any pertinent visibility requirements for the operator. Mount with the 1/4" hardware.

4. Plumbing

Thread fitting elbow or straight fitting (003-EL3812 or 003-A3812) into sump of tank. From the tank the hose will run to the filter bowl side of the pump, followed by running to the gauge, and from the gauge to the main tee fitting shown on the bottom of page 7. Secure all connections with hose clamps. Make sure to keep hose away from hydraulic lines, out of the way of moving parts, and away from doors or shields that may need to be moved. **DO NOT RUN THE HOSE BETWEEN THE TANK MOUNTING FRAME AND THE TANK.**

Weight Distribution Chart

7200	7300/7400/7500	7700	7800										
outside	outside	outside	outside										
Header Type	Weight header kg	40 kg Suitcase weights	45 kg Suitcase weights	40 kg Suitcase weights	45 kg Suitcase weights	50 kg Suitcase weights	40 kg Suitcase weights	45 kg Suitcase weights	50 kg Suitcase weights	40 kg Suitcase weights	45 kg Suitcase weights	50 kg Suitcase weights	Rear axle
630	1060 kg	8	6	0	0	0	0	0	0	0	0	0	standard
		4	4	0	0	0	0	0	0	0	0	0	powered
640	1150 kg	8	8	0	0	0	0	0	0	0	0	0	standard
		4	4	0	0	0	0	0	0	0	0	0	powered
645	1275 kg	12	10	2	2	2	2	2	0	0	0	0	standard
		8	6	0	0	0	0	0	0	0	0	0	powered
684	1470 kg	14	12	8	8	6	10	8	8	4	4	2	standard
		12	10	6	6	4	6	6	4	0	0	0	powered
676	1940 kg	22	20	16	14	14	18	16	14	12	10	10	standard
		20	18	14	12	10	16	14	12	10	8	6	powered
686	2260 kg	24	22	20	18	16	22	20	18	16	14	12	standard
		22	20	16	14	14	18	16	14	12	10	10	powered
688	2725 kg	not compatible		-	-	26	-	-	28	-	-	24	standard
		not compatible		-	24	22	-	-	26	24	22	20	powered
710	3375 kg	not compatible		-	-	-	-	-	-	-	-	28	standard
		not compatible		-	-	28	-	-	28	-	-	28	powered
664	1130 kg	10	8	2	2	2	0	0	0	0	0	0	standard
		8	6	0	0	0	0	0	0	0	0	0	powered
666R	1520 kg	16	14	10	10	8	12	12	10	6	6	4	standard
		14	12	10	8	8	8	8	8	2	2	2	powered

5. Mounting the Spout Nozzle Assembly (Optional Kit 030-6712)

1. The spout nozzle will mount on the back of the spout.
2. First, locate and mark the location of the hole where the nozzle will fit into the spout.
3. Drill the hole for the spout nozzle, which should be $11/16$ " in diameter. The material lining in the spout is extremely difficult to drill through so be sure to have a sharp bit.
4. Once the spout nozzle hole is drilled, place the assembly on the spout and weld the plate with the threaded studs to the spout. Only the two outer edges need to be welded to the spout.
5. Be sure to remove excess slag on the welded plate so that the nozzle plate fits securely.
6. The plate containing the nozzle will fit on top of the plate welded to the spout. Fasten the nozzle plate using lock washers and $5/16$ " nuts. Before fastening, be sure that the nozzle is inserted in the spout so it sprays upward and to the right at approximately a 45-degree angle.

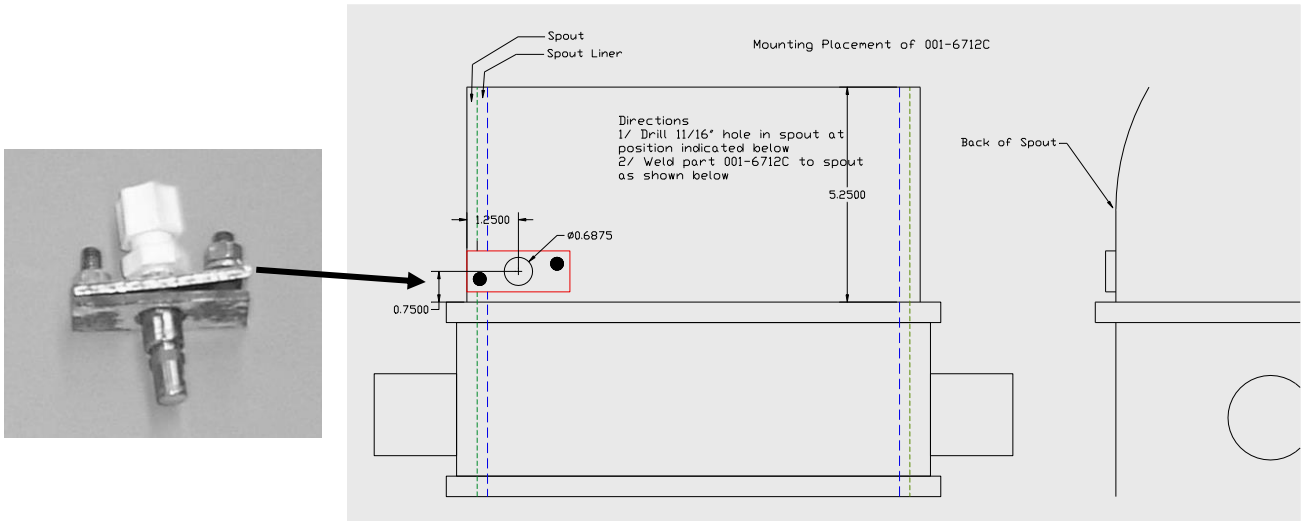

6. Feed Roll Nozzle

1. Locate the accelerator.
2. Install nozzle strap to the existing holes with the supplied hardware.

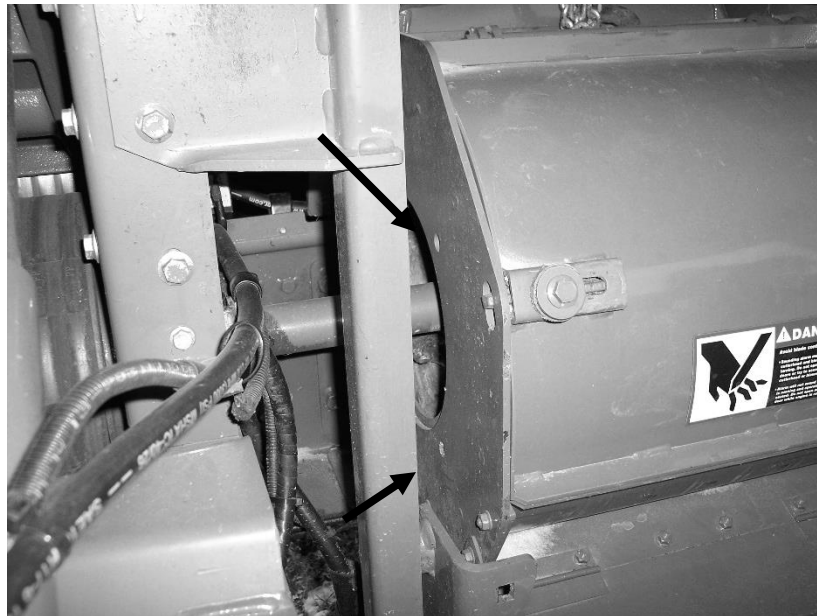

7. Installation of the Lower Chute – Chute Lube Bar

Gumming from crops can be reduced by spraying water from under the crop in the chute between the cutter head and the accelerator. The chute lube bar mounts in the grass transition chute 2" behind the spiral floor edge. Six holes will need to be drilled in the chute, four 9/16" holes for the spray nozzles and two 3/8" holes for bolting the spray bar in place.

Place the spray bar on the chute and mark the location for the 9/16" and 3/8" holes. Use the enclosed 5/16" x 2 inch black allen head bolts to hold the spray bar in place. Make sure the bolts are inserted from inside the chute to minimize build-up. Note: Washers (not included) may need to be used on the bolts in-between the spray bar and chute so the tips of the spray nozzles are flush with the inside of the chute. Run 1/2" hose from elbow on bar to discharge of tee assembly shown.

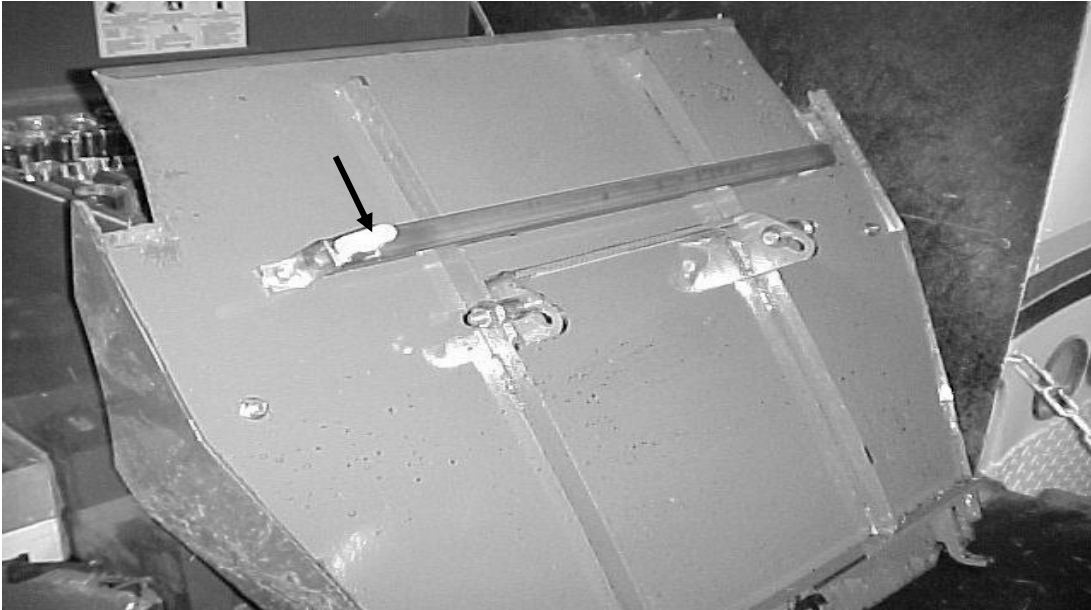

8. Connecting the Spout, Feed Roll, and Chute Nozzle Plumbing

1. The enclosed tee assembly should be placed in the line after the pressure gauge.
2. To run the chute lubricator only, keep the enclosed cap on the tee.
3. To run the spout nozzle only, replace the quick connect that goes to the spout with the quick connect that goes to the chute.
4. To run feed roll sprayer only, keep the enclosed cap on the tee.
5. To run two nozzles at a time, place both quick connects going to the nozzles on the tee. Note only two can be used at a time.

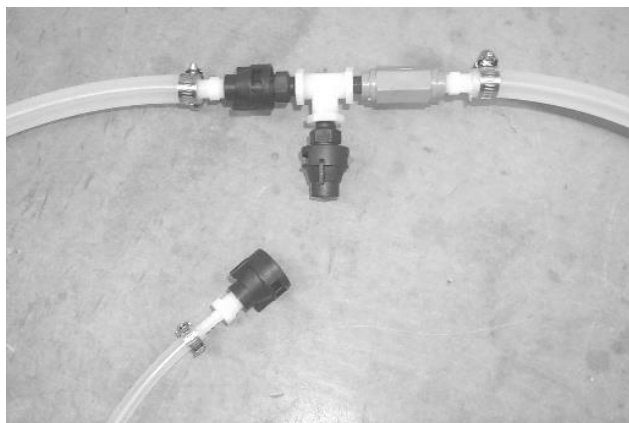

9. Wiring of Controls

1. The self-propelled forage harvester should have order code 6024 or you will need to order
2. Bundle B713547
3. Locate power cord (006-4580) in sprayers install kit box 030-6707 and plug it into the back of the control.
4. Locate harness (AZ100126) that came with the Forage Harvester. It has a green wire (065), black wire (310) and red wire (122)
5. Connect green wires together with connectors provided and slide shrink tubing over connection.
6. Connect black wires together with connectors provided and slide shrink tubing over connection.
7. Heat shrink tubing with a hot air gun or hair dryer. Be careful not to melt wires or coating.
8. Red wire is not used. Terminate it so it doesn't spark. This wire will supply 12 VDC all the time.
9. Plug harness (AZ100126) into socket located underneath headlights on the right fender.

Operating Instructions

1. To operate unit using the machines input, press the Liquid Injection Pump Switch **ONCE**. (Located on right hand arm rest control panel) All of the following has to be present before the power is supplied to the sprayer.
 - The road safety switch is in field operating mode
 - The forage harvester is traveling forward
 - The ground speed is greater than 1.25 mph
 - The feed rolls are turning in forward direction
 -
2. To allow sprayer to run all of the time, press the Liquid Injection Pump Switch **TWICE**
Note: When the Liquid Injection Pump Switch is in standby mode, the tank indicator icon on the corner post will flash. When the pump is running the icon will display solid. Also, there is a light next to the switch that will light up when the switch is activated.
3. To increase pressure, turn dial on sprayers control box to the right. To decrease pressure, turn dial to left.
4. **If the LED light behind the speed dial starts to blink, use the troubleshooting guide as a reference.**
5. For more information refer to the 7000 Series Operators Manual on pages (15-13, 20-64,110-7)

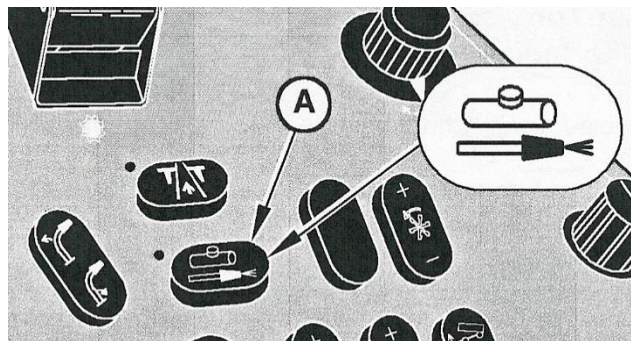

Application Instructions

The model 676 is compatible with water, bacterial inoculants, enzymes, and organic acid crop preservatives. All of these liquids are similar to water in weight and viscosity, so the charts below will be accurate within 10% for all products used if the system is functioning properly. Always verify application by checking product used against desired application per hour.

Look over the chart below and select the spray tip that will provide the desired range of application. Adjust the pressure with the control box to the setting from the chart below.

GALLONS PER HOUR					
TIP Number	PRESSURE				
	20 PSI	30 PSI	40 PSI	50 PSI	60 PSI
11002 (Yellow)	8	10	12	14	15
11004 (Red)	17	21	24	27	29
11008 (White)	34	41	48	53	59
11015 (Silver)	63	78	90	100	110
1/8 KSS 1 (opt)	8	10	12	14	15
1/8 KSS 2 (opt)	17	21	24	27	29
1/8 KSS 4 (opt)	34	41	48	53	59
JD Chute bar	29	32	35	38	NA

Routine Maintenance

1. Clean the tip strainers and main strainer every 10 hours of operation or more frequently if required.
2. When inoculants are being used, the system will need to be drained and flushed with water after each use to prevent residue build up.
3. Although the pump can run dry, extended operation of a dry pump will increase wear. Watch the fluid level in the tank.
4. Pump performance may start to decline after 400 hours of use. Rebuilding the pump is a simple procedure if the motor is not damaged. Order pump rebuilding kit #007-4581.

Winter Storage

1. Thoroughly flush the system with water.
2. Remove the filter bowl and run dry until the water has cleared out of the intake side.
3. Remove the red plug from the bottom of the pump, drain, and run the pump for 30 seconds or until it is dry.
4. Drain all lines on the outlet side.
5. Never use oils or alcohol based anti-freeze in the system.
6. For spring start-up, or anytime the pump is frozen, turn off the power immediately to avoid burning the motor out. The pump head can be disassembled and freed or rebuilt in most cases.

Troubleshooting

PROBLEM	POSSIBLE CAUSE	SOLUTION
Pump will not run.	1. Circuit breaker tripped on electronic unit.	1. Check for short, low voltage, and reset breaker.
	2. Pump locked up.	2. Clean or rebuild pump if motor is OK.
	3. Damaged wire.	3. Repair damaged wire.
	4. Vapor locked.	4. Loosen hose by check valve at gauge and bleed air.
Pump runs but will not prime.	1. Air leak in intake.	1. Tighten fittings on intake side.
	2. Clogged intake.	2. Clean.
	3. Restricted outlet.	3. Check and clean tips.
	4. Check valve on outlet stuck closed.	4. Clean or repair check valve.
	5. Dirt inside pump.	5. Replace pump check valve.
Pump does not develop enough output.	1. Air leaks or clogs on inlet side.	1. Tighten or clean filter bowl assembly.
	2. Electronic box out of adjustment.	2. Refer to box adjustment page.
	3. Pump worn or dirty.	3. Rebuild pump.
	4. Low supply voltage. (Pump requires 12v minimum)	4. Check voltage at connection with voltmeter.
	5. Bad gauge.	5. Gauge should read less than 10 PSI when not in use. Also tips should lose spray pattern below 10 PSI. Check accuracy.
Pump output varies.	1. Clogged or restricted inlet.	1. Clean
	2. Worn pump parts.	2. Rebuild pump.
	3. Pump not primed.	3. Prime pump.
Message light blinks two times	1. Pump or wire harness shorted.	1. Check harness running to pump and verify no shorts or problems. 2. Check to see if pump motor is locked up. Repair or replace.
Message light blinks three times	1. Pump is drawing greater than 10 amps.	1. Check to see if motor is running correctly. Repair or replace.
Message light blinks four times	1. Undercurrent coming to control box.	1. Check all battery connections and connections running up to control box.

676 Parts Breakdown for Saddle and Tank

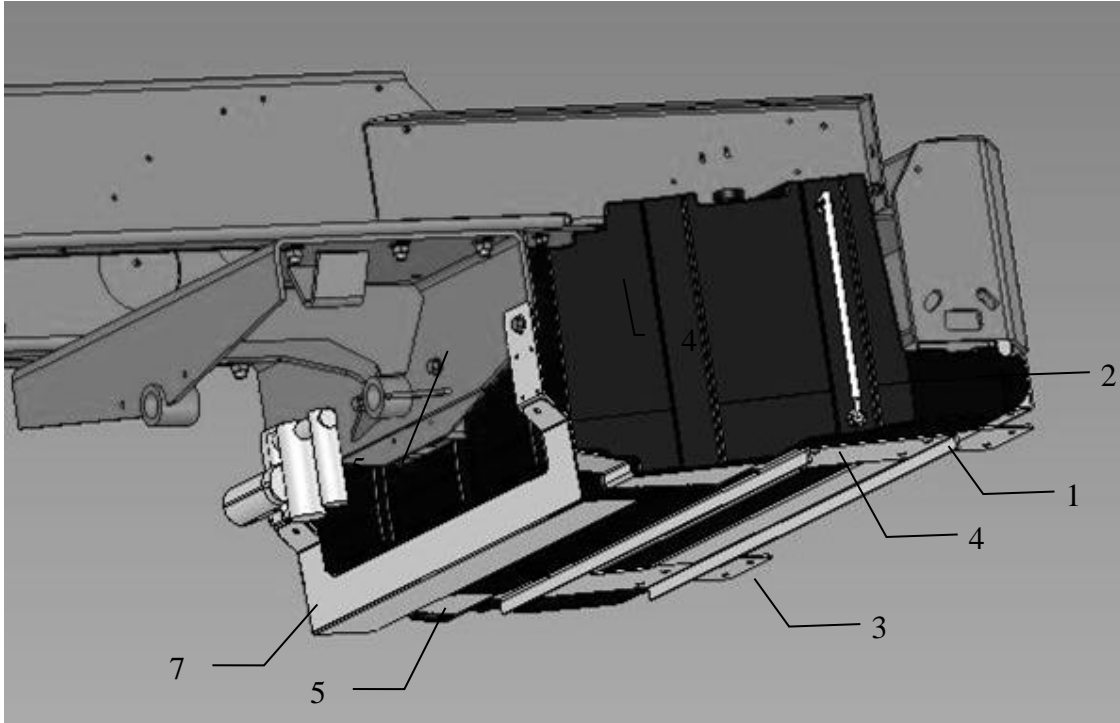

<u>Ref</u>	<u>Description</u>	<u>Part #</u>	<u>Qty</u>
	Tank Kit Complete	005-9209P	
1	Tank	005-9209	1
2	Left Hanger Extension	001-6708L	1
3	Right Hanger Extension	001-6708R	1
4	Left Tank Hanger	001-6709L	1
5	Right Tank Hanger	001-6709R	1
6	Cross Brace	001-6709X	1
7	Stalk Protector	001-6709S	1
NP	Tank Breather	005-9022B2	1
NP	Tank Cap – 4"	005-9209C	1
NP	Tank Ring – 4"	005-9209R	1
NP	Tank Gasket – 4"	005-9209G	1

Tanks 2010 and older have two lids. The lid that is no longer used replacement part number is 005-9207B2.

676 Control Box Assembly

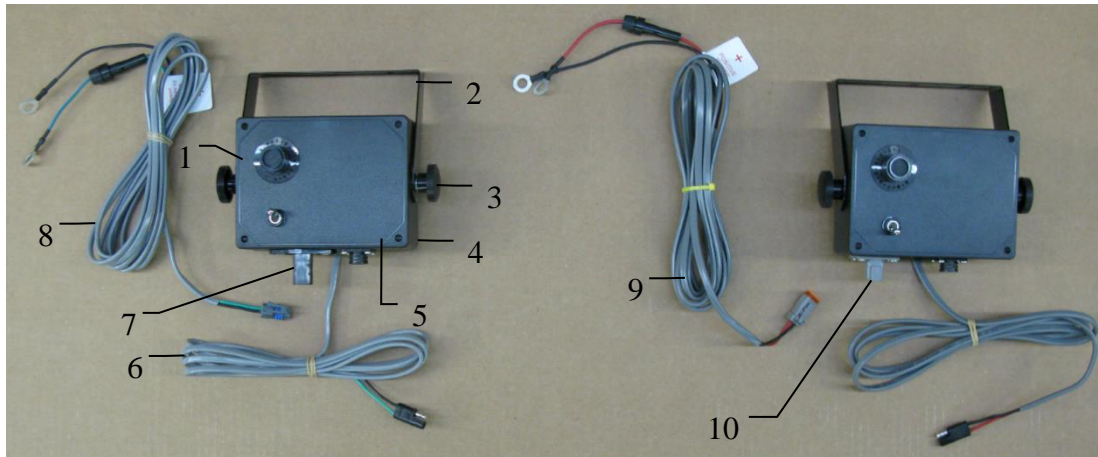

<u>Ref</u>	<u>Description</u>	<u>Part #</u>	<u>Qty</u>	<u>Ref</u>	<u>Description</u>	<u>Part #</u>	<u>Qty</u>
1	Speed dial	006-2022A	1	8	Power lead	006-4580C	1
2	U-bracket	001-2012E	1		<i>Pre-Serial # 4550</i>		
3	Control box knob	008-0923	2	9	Power lead	006-4580M	1
4	Control box enclosure	006-2015A	1		<i>After Serial # 4550</i>		
5	Control box cover	006-2015B	1	10	Box Plug	006-4581M	1
6	Pump lead	006-4583	1		<i>After Serial # 4550</i>		
7	Box Plug	006-4581					

Complete Assembly 030-0457B

Pump and Gauge Assembly

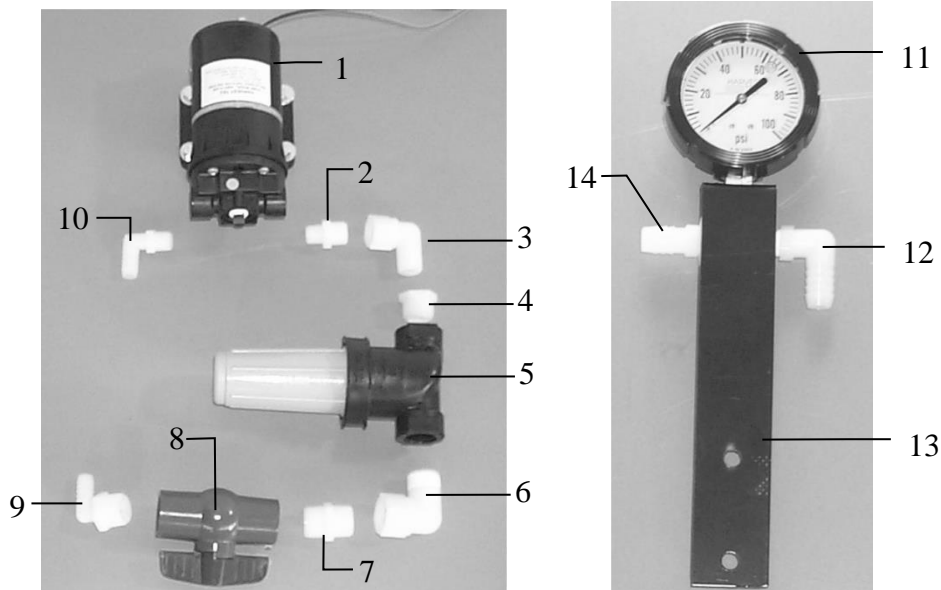

<u>Ref</u>	<u>Description</u>	<u>Part #</u>	<u>Qty</u>	<u>Ref</u>	<u>Description</u>	<u>Part #</u>	<u>Qty</u>
1	Pump	007-4120S	1	10	Elbow fitting	003-EL3812	1
2	Nipple fitting	003-M1238	1	NP	Replacement Screen	002-4315A	1
3	Street elbow fitting	003-SE12	1	NP	Filter Bowl Gasket	002-4318B	1
4	Reducing bushing fitting	003-RB3412	1				
5	Filter bowl	002-4318	1	11	Gauge	002-2207Z	1
6	Street elbow fitting	003-SE34	1	12	Straight fitting	003-A1412	1
7	Nipple fitting	003-M3434	1	13	Gauge holder bracket	001-6704	1
8	Ball valve	002-2200	1	14	Elbow fitting	003-EL1412	1
9	Elbow fitting	003-EL3412	1				

Parts Breakdown John Deere 7000 Series Mounting Kit

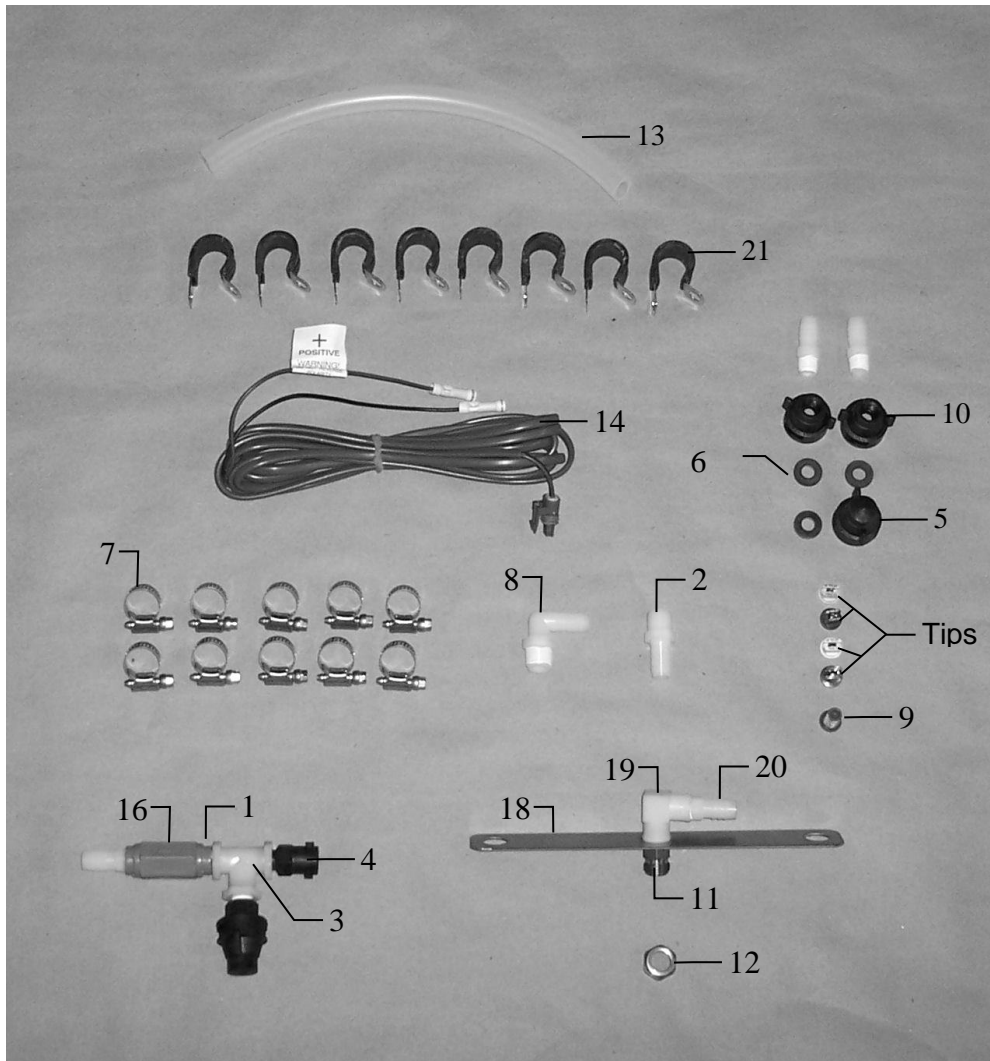

<u>Ref.</u>	<u>Description</u>	<u>Part #</u>	<u>Qty</u>	<u>Ref.</u>	<u>Description</u>	<u>Part#</u>	<u>Qty</u>
1	Nipple	003-M14	1	13	Tubing	002-9001	70 ft
2	Straight fitting	003-A3812	5	14	Power cord	006-4580M	1
3	Tee fitting	003-TT14	1	15	Elbow fitting	003-EL1412	1
4	Quick connect fitting	004-4710	2	16	Check valve	002-4564F	1
5	Cap	004-1207F	1	17	Chute lube bar	001-6711A	1
6	Washer	004-1207W	1	18	Nozzle strap	001-4216P	1
7	Hose clamp-#6	003-9003	10	19	Elbow	003-SE14F	1
8	Elbow	003-EL3812	1	20	Straight fitting	003-A1412	4
9	Screen	004-1203-100	1	21	Jiffy clip	008-9010	8
10	Quick connect fitting	004-1207H	3		Tip (Yellow)	004-XR11002VS	1
11	Nozzle body	004-4722	1		Tip (Red)	004-XR11004VS	1
12	Nozzle cap	004-4723	1		Tip (White)	004-XR11008VS	1
					Tip (Silver)	004-11015-SS	1

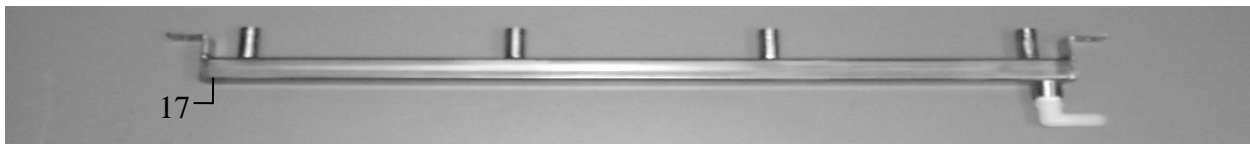

Optional Spout Nozzle Assembly

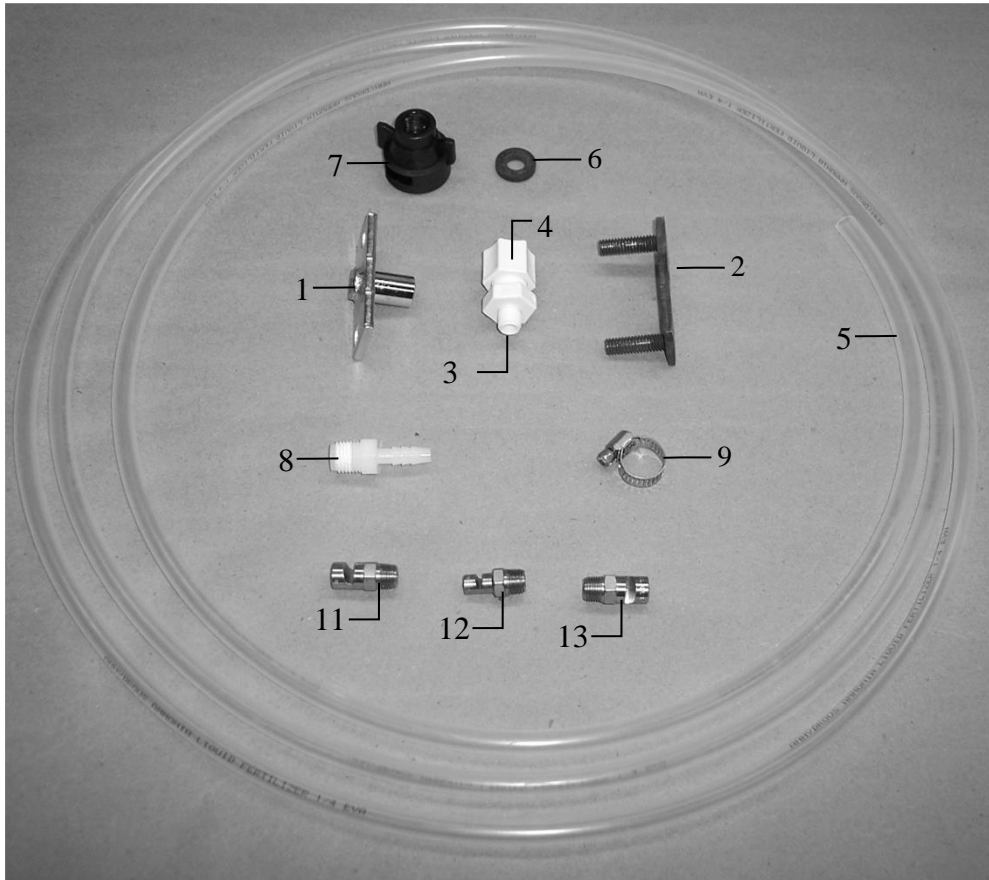

<u>Ref.</u>	<u>Description</u>	<u>Part #</u>	<u>Qty</u>
1	Nozzle holder	001-6712A	1
2	Nozzle base	001-6712B	1
3	Jaco fitting	003-JA1418	1
4	Jaco nut	003-JN14	2
5	Hose	002-9006	10
6	Washer	004-1207W	1
7	Female disconnect	004-1207H	1
8	Straight fitting	003-A1414	1
9	Hose clamp	003-9002	1
11	Tip	004-K1-SS	1
12	Tip	004-K4-SS	1
13	Tip	004-K2-SS	1
1-13	Complete assembly	030-6712	1

Harvest Tec, LLC. Warranty and Liability Agreement.

Harvest Tec, LLC. will repair or replace components that are found to be defective within 12 months from the date of manufacture. Under no circumstances does this warranty cover any components which in the opinion of Harvest Tec, LLC. have been subjected to negligent use, misuse, alteration, accident, or if repairs have been made with parts other than those manufactured and obtainable from Harvest Tec, LLC.

Our obligation under this warranty is limited to repairing or replacing free of charge to the original purchaser any part that in our judgment shows evidence of defective or improper workmanship, provided the part is returned to Harvest Tec, LLC. within 30 days of the failure. Parts must be returned through the selling dealer and distributor, transportation charges prepaid.

This warranty shall not be interpreted to render Harvest Tec, LLC. liable for injury or damages of any kind, direct, consequential, or contingent, to persons or property. Furthermore, this warranty does not extend to loss of crop, losses caused by delays or any expense prospective profits or for any other reason. Harvest Tec, LLC. shall not be liable for any recovery greater in amount than the cost or repair of defects in workmanship.

There are no warranties, either expressed or implied, of merchantability or fitness for particular purpose intended or fitness for any other reason.

This warranty cannot guarantee that existing conditions beyond the control of Harvest Tec, LLC. will not affect our ability to obtain materials or manufacture necessary replacement parts.

Harvest Tec, LLC. reserves the right to make design changes, improve design, or change specifications, at any time without any contingent obligation to purchasers of machines and parts previously sold.

Revised 6/22

HARVEST TEC, LLC.
P.O. BOX 63
2821 HARVEY STREET
HUDSON, WI 54016
PHONE: 715-386-9100
1-800-635-7468
FAX: 715-381-1792
Email: info@harvesttec.com