

# OWNER'S MANUAL

**Model 9214**

**HIGH OUTPUT 12 VOLT TRANSFER PUMP**

HARVEST  
TEC

*Equipment and Products  
for Quality Hay.*

## Introduction

Congratulations on purchasing a Harvest Tec Model 9214 transfer pump. This system is designed to transfer Harvest Tec buffered propionic acid. The model 9214 base kit includes the following parts: Pump, Hose, Fittings, Drain Fill Kit, and Miscellaneous Hardware. The transfer pump can be used Harvest Tec 55 gallon drums as well as 200 gallon totes with the included adapters. Before installing the unit on the baler, make sure you have the proper installation kit. For your convenience we have included a parts break down for the model 9214 transfer pump. If replacement parts are needed, bring this manual into the dealership so they can order the correct parts for you.

## Technical Information

### Design Features

- 15 PSI maximum outlet pressure
- 2600 RPM, 1/4 HP motor:
- 12 VDC rated at 20 amps
- Thermal overload protection of the motor
- 20 ft. long power cable with battery clips and a 30 amp fuse.
- Positive displacement/self-priming design
- Can pass particulate materials up to 0.100" diameter in the pumped fluids
- Flow easily controlled by outlet throttling from maximum to zero
- Pump may run dry without damage
- Handles viscosities from 1.0 CPS to 3700 CPS
- Minimum shear (agitation) of pumped fluids
- Minimum operating ambient temperature: -10°F (-23°C)
- Maximum operating ambient temperature: 130°F (54°C)
- Maximum 30 minute duty cycle, not for continuous operation.

## Assembly

Remove the transfer pump and the parts box from the shipping carton. Remove the parts bag from within the parts box and locate the four 1/4" bolts and washers (5 & 6). Attach the carrier (18) to the top of the pump and tighten to 10 ft-lbs.

Apply Teflon tape to a black 1" MPT x 1" HB (1) fitting and thread into the top discharge port of the pump and insert pump probe (9) into the bottom intake port. Attach the 12' EPDM hose to the fitting using a 1" hose clamp (4).

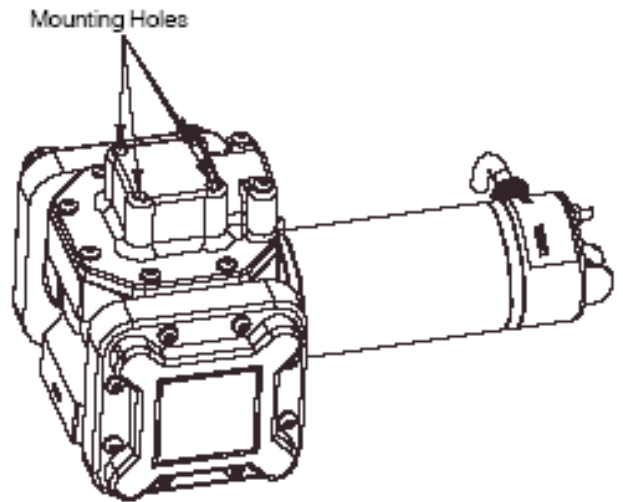

If using drain/fill line:

Attach second black hose fitting (1) to the EPDM hose with a hose clamp (4) followed by a 1" ball valve (15) and male coupler (12).

If using nozzle ball valve:

Attach second black hose fitting (1) to the EPDM hose with a hose clamp (4) followed by the 1" nozzle ball valve (21).

## Installation of Drain/Fill Line

If your preservative applicator was originally equipped with a drain/fill line, it will need to be fitted with the enclosed parts to ensure the 15 gallon per minute flow rate. Failure to do so will restrict the output of the transfer pump.

- A) Remove existing drain/fill line, leaving only the bung fitting in the tank.
- B) Thread 3/4" MPT x 1" HB elbow fitting (2) into the end of the tank.
- C) Run 1" hose from the elbow down the frame to the bottom of the baler.
- D) Attach new valve holder (8) to baler frame using existing hardware.
- E) Thread female coupler (11) through valve holder and into 1" ball valve (15) followed by a 1" MPT x 1" HB (1).
- F) Attach 1" hose between elbow and valve assembly using hose clamps (4).

## Electrical Installation

Connect cable to 12 volt DC power supply as follows, paying special attention to wire colors:

Pump	Cable
Positive	Red
Negative	Black

If pump is to be powered from a vehicle power system it is recommended that permanent wiring and connections be made to vehicle power system which includes a 30 amp slow blow fuse.

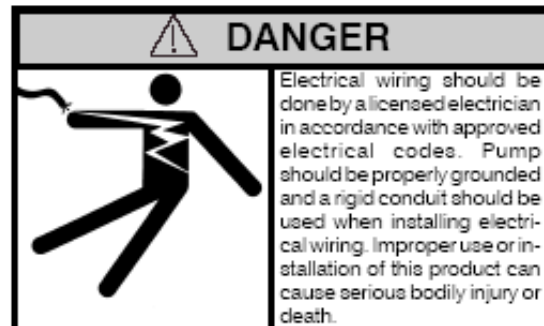
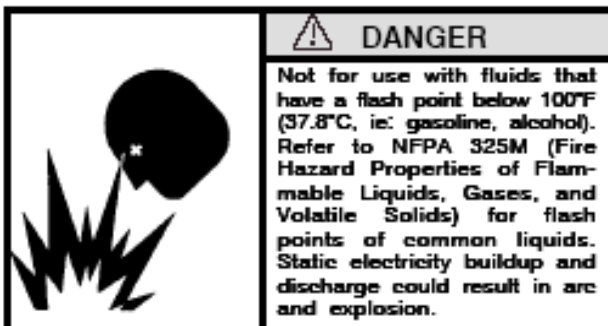

## Operating Instructions

The 9214 transfer pump can be used on either 450# drums or 1800# totes using the supplied adapters.

If using drums:

Remove one of the caps from the drum, adapters for both the 2" NPT (14) and buttress (11) fittings are included. Attach the telescoping suction tube (16) to the desired adapter and insert into the drum. Be sure to unscrew the other plug to allow for venting. Attach the pump to the adapter by inserting the pump probe into the adapter and tightening the collar clamp attached to the pump base.

If using totes:

Remove the 6" tote cap and replace with the included cap (17). The included cap has a breather installed to prevent the tote from collapsing. Attach the telescoping suction tube (16) to the 2" NPT adapter and insert into the tote through the cap. Attach the pump to the adapter by inserting the pump probe into the adapter and tightening the collar clamp attached to the pump base.

Attach the pump to either the drain/fill line or insert the nozzle valve into the tank and turn the toggle switch on. The pump has an internal bypass and can run with the nozzle or ball valve turned off. Once the desired amount of chemical has been transferred, close the ball or nozzle valve and turn off the pump.

If the pump is removed from the drum or tote, but the adapter is left in place, a dust shield (19) and collar (20) is included to prevent contamination.

## Fluid Compatibility

**\*Warning: The pump, hose and fittings must be thoroughly flushed if used for transferring non-food grade materials prior to use with forage preservatives.**

AGCO Buffered Acid	Caustic Soda (50%)	Motor Oil	Zinc + Citric Acid Mix
Ammonium Sulfate	CropSaver®	Princep 4L®	Zinc Chloride
Antifreeze	Dual®	Phosphoric Acid	Zinc Hydrosulfite
Atrazine 4L®	Eptam 7E®	Potash	Zinc Sulfate
Baler's Choice®	Fultime®	Prowl®	2-4 D
Banvel®	Furadan®	Pursuit®	Touchdown®
Bicep®	Guardzman®	Roundup®	Malathion
Gramoxone Extra®	Karate®	Sodium Hydroxide (50%)	
Harness Xtra®	Lasso Micro Tech®	Thirty Plus®	
Hydraulic Oil	Methyl Parathion	Transmission Fluid	

## Maintenance

To keep pump running at its best, periodically perform the following procedures. (Refer to exploded view drawing of pump)

**Chemical Applications** Do not allow chemical to remain in the pump for any extended period of time, whereby the chemicals are allowed to "dry out." Thoroughly rinse pump by flushing the pump with water or appropriate flushing fluid.

**DO NOT USE PRESSURIZED WATER OR PRESSURIZED AIR** to flush your pump. Damage to the equipment can occur if flush water pressure exceeds 15psi (1 bar). Instead, submerge the suction tube or inlet adapter in clean water and dispense water by operating the pump. Dispose of the flush water properly. After flushing, pump air to remove as much water as possible.

## Maintenance (continued)

**All Applications** on annual basis or as needed.

1. Tighten all external screws to 50 in. lbs. NOTE: NEVER EXCEED 50 IN. LB. TORQUE WHEN TIGHTENING SCREWS.

2. Drain oil through sight caps and replace oil with approximately 16 ounces of automotive grade SAE 30W through one of the sight cap holes. The oil level should be level with the bottom edge of the sight caps located on the front of the pump body. NOTE: Always check oil level when the pump is level.

3. Check the four #10-24 x 1/2" machine screws holding the diaphragm in place. If loose, tighten screws to 35 in. lbs. to prevent internal leakage. NOTE: If external screws are removed, hand start and tighten to 50 in. lbs.

## Troubleshooting

TROUBLESHOOTING GUIDE		
PROBLEM	POSSIBLE CAUSE	SOLUTION
Pump won't prime	<ul style="list-style-type: none"> <li>• Suction line problem</li> <li>• Leaky check valves</li> <li>• Check valves improperly installed</li> <li>• Outlet plugged</li> <li>• Motor not operating</li> <li>• Stripped or damaged gears</li> </ul>	<ul style="list-style-type: none"> <li>• Check for leaks in suction line.</li> <li>• Check for dirt or damaged check valves and replace.</li> <li>• Check for proper installation.</li> <li>• Check for blockage and clear.</li> <li>• Check power source.</li> <li>• Repair or replace motor.</li> <li>• Check gear assembly and drive gear for damage. Replace complete assembly if necessary.</li> </ul>
Pump hums but will not rotate	<ul style="list-style-type: none"> <li>• Motor faulty</li> <li>• Gear mechanism jammed</li> </ul>	<ul style="list-style-type: none"> <li>• Replace motor.</li> <li>• Check for free rotation of the gears.</li> </ul>
Low pump capacity	<ul style="list-style-type: none"> <li>• Low voltage</li> <li>• Leaky suction line</li> <li>• Dirt in check valves</li> <li>• Faulty check valves</li> <li>• One or both diaphragms leaking</li> <li>• One piston screw loose</li> <li>• Piston retainer screws loose</li> <li>• Debris ingested</li> </ul>	<ul style="list-style-type: none"> <li>• Check power source.</li> <li>• Repair leaks.</li> <li>• Dismantle and clean.</li> <li>• Install repair kit.</li> <li>• Install repair kit.</li> <li>• Install new yoke assembly.</li> <li>• Install new yoke assembly.</li> <li>• Add inlet screen.</li> </ul>
Motor overheats	<ul style="list-style-type: none"> <li>• Pumping hot fluids</li> <li>• Motor faulty</li> </ul>	<ul style="list-style-type: none"> <li>• Shorten duty cycle.</li> <li>• Replace motor.</li> </ul>
Fluid leakage	<ul style="list-style-type: none"> <li>• Faulty or missing gaskets</li> <li>• Loose bolts</li> <li>• Cracked component</li> </ul>	<ul style="list-style-type: none"> <li>• Install all gaskets specified in parts list.</li> <li>• Torque all bolts to 50 in. lbs.</li> <li>• Replace defective component.</li> </ul>

## Parts Breakdown 9214 Transfer Pump

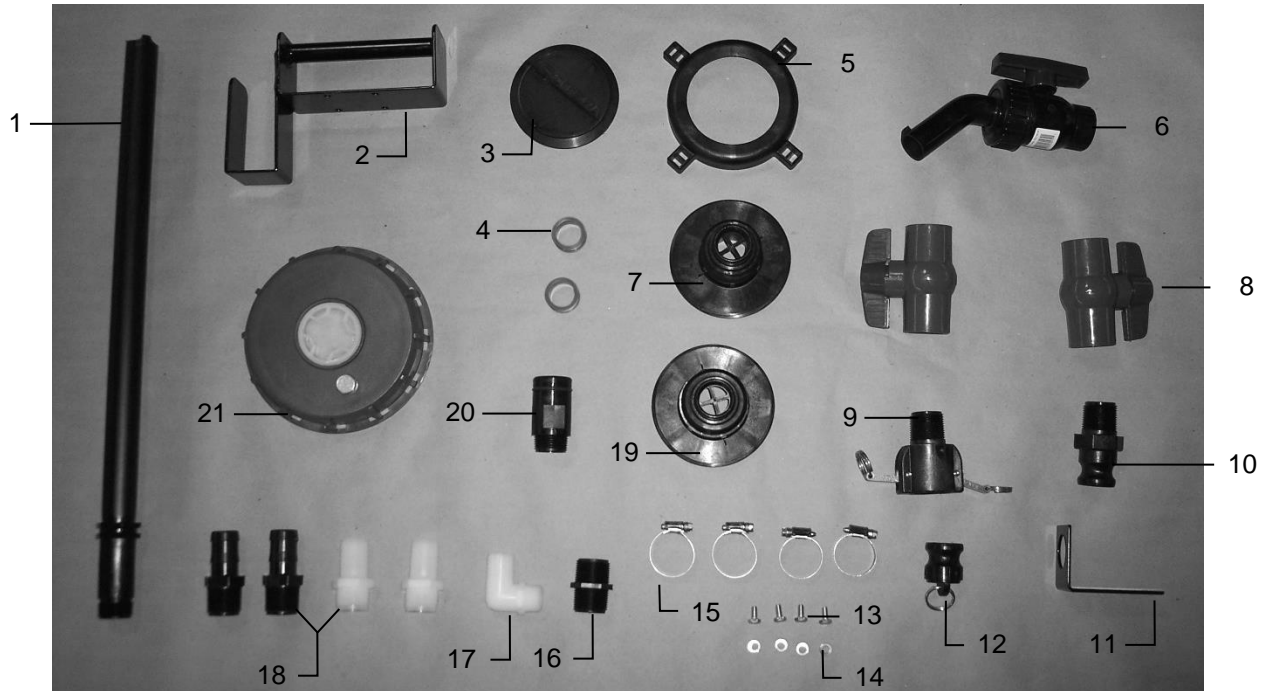

<u>Ref</u>	<u>Description</u>	<u>Part #</u>	<u>Qty</u>	<u>Ref</u>	<u>Description</u>	<u>Part Number</u>	<u>Qty</u>
1	Telescoping Suction Tube	003-TP1005	1	14	1/4-20 x 1/2" Bolt	NA	4
2	Carrier	001-4572	1	15	1" Hose Clamp	003-9007	4
3	Dust Shield	003-TP1006	1	16	1" MPT Nipple	003-M100100	1
4	Mini Teflon Roll	003-TP1002	2	17	3/4" MPT x 1" HB Elbow	003-EL34100	1
5	Collar Clamp	003-TP1007	1	18	1" MPT x 1" HB Straight	003-A100100	4
6	Nozzle Ball Valve	003-TP1008	1	19	Butress Tank Adapter	003-TP1003	1
7	2" NPT Adapter	003-TP1004	1	20	Pump Probe w/ O-Ring	003-TP1001	1
8	1" Ball Valve	002-2210	2	21	Bulk Cap 6" w/ Breather	005-9204PC	1
9	Female Coupler	002-2204L	1	22	12VDC 15GMP Pump	007-7000	1
10	Male Coupler	002-2204O	1	23	Pump Flange	003-TP1009	1
11	Valve Bracket	001-6702I	1	NP	1" EVA Hose (clear)	002-9013	5 ft
12	1" Plug	002-2204M	1	NP	1" EPDM Hose (black)	003-TP1010	12 ft
13	1/4" Lock Washer	NA	4				

## **Harvest Tec LLC. Warranty and Liability Agreement**

Harvest Tec, LLC. will repair or replace components that are found to be defective within 12 months from the date of manufacture. Under no circumstances does this warranty cover any components which in the opinion of Harvest Tec, LLC. have been subjected to negligent use, misuse, alteration, accident, or if repairs have been made with parts other than those manufactured and obtainable from Harvest Tec, LLC.

Our obligation under this warranty is limited to repairing or replacing free of charge to the original purchaser any part that in our judgment shows evidence of defective or improper workmanship, provided the part is returned to Harvest Tec, LLC. within 30 days of the failure. If it is determined that a non-Harvest Tec branded hay preservative has been used inside the Harvest Tec applicator system where the failure occurred, then Harvest Tec reserves the right to deny the warranty request at their discretion. Parts must be returned through the selling dealer and distributor, transportation charges prepaid.

This warranty shall not be interpreted to render Harvest Tec, LLC. liable for injury or damages of any kind, direct, consequential, or contingent, to persons or property. Furthermore, this warranty does not extend to loss of crop, losses caused by delays or any expense prospective profits or for any other reason. Harvest Tec, LLC. shall not be liable for any recovery greater in amount than the cost or repair of defects in workmanship.

There are no warranties, either expressed or implied, of merchantability or fitness for particular purpose intended or fitness for any other reason.

This warranty cannot guarantee that existing conditions beyond the control of Harvest Tec, LLC. will not affect our ability to obtain materials or manufacture necessary replacement parts.

Harvest Tec, LLC. reserves the right to make design changes, improve design, or change specifications, at any time without any contingent obligation to purchasers of machines and parts previously sold.

Revised 4/22

**HARVEST TEC, LLC.**  
**P.O. BOX 63**  
**2821 HARVEY STREET**  
**HUDSON, WI 54016**  
PHONE: 715-386-9100  
1-800-635-7468  
FAX: 715-381-1792  
Email: [info@harvesttec.com](mailto:info@harvesttec.com)